

TOSHIBA TRANSISTOR SILICON NPN EPITAXIAL PLANAR TYPE

# 2SC5097

VHF~UHF BAND LOW NOISE AMPLIFIER APPLICATIONS

Unit in mm

- Low Noise Figure, High Gain.
- $NF=1.8dB$ ,  $|S_{21e}|^2=10dB$  ( $f=2GHz$ )

MAXIMUM RATINGS ( $T_a = 25^\circ C$ )

CHARACTERISTIC	SYMBOL	RATING	UNIT
Collector-Base Voltage	$V_{CBO}$	20	V
Collector-Emitter Voltage	$V_{CEO}$	10	V
Emitter-Base Voltage	$V_{EBO}$	1.5	V
Base Current	$I_B$	7	mA
Collector Current	$I_C$	15	mA
Collector Power Dissipation	$P_C$	150	mW
Junction Temperature	$T_j$	125	$^\circ C$
Storage Temperature Range	$T_{stg}$	-55~125	$^\circ C$

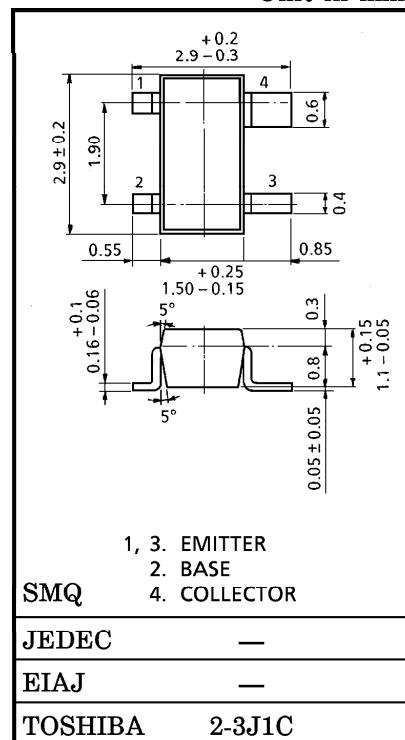

MARKING

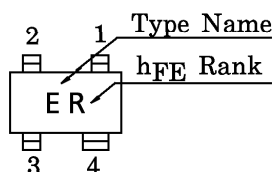

MICROWAVE CHARACTERISTICS ( $T_a = 25^\circ C$ )

CHARACTERISTIC	SYMBOL	TEST CONDITION	MIN.	TYP.	MAX.	UNIT
Transition Frequency	$f_T$	$V_{CE}=6V, I_C=7mA$	7	10	—	GHz
Insertion Gain	$ S_{21e} ^2 (1)$	$V_{CE}=6V, I_C=7mA, f=1GHz$	12.5	15.5	—	dB
	$ S_{21e} ^2 (2)$	$V_{CE}=6V, I_C=7mA, f=2GHz$	7	10	—	
Noise Figure	NF (1)	$V_{CE}=6V, I_C=3mA, f=1GHz$	—	1.3	2.5	dB
	NF (2)	$V_{CE}=6V, I_C=3mA, f=2GHz$	—	1.8	3.0	

ELECTRICAL CHARACTERISTICS ( $T_a = 25^\circ C$ )

CHARACTERISTIC	SYMBOL	TEST CONDITION	MIN.	TYP.	MAX.	UNIT
Collector Cut-off Current	$I_{CBO}$	$V_{CB}=10V, I_E=0$	—	—	1	$\mu A$
Emitter Cut-off Current	$I_{EBO}$	$V_{EB}=1V, I_C=0$	—	—	1	$\mu A$
DC Current Gain	$h_{FE}$ (Note 1)	$V_{CE}=6V, I_C=7mA$	50	—	160	—
Output Capacitance	$C_{ob}$	$V_{CB}=10V, I_E=0, f=1MHz$	—	0.5	0.9	pF
Reverse Transfer Capacitance	$C_{re}$		(Note 2)	—	0.35	0.85

(Note 1)  $h_{FE}$  Classification R : 50~100, O : 80~160

(Note 2)  $C_{re}$  is measured by 3 terminal method with capacitance bridge.

961001EAA2

- TOSHIBA is continually working to improve the quality and the reliability of its products. Nevertheless, semiconductor devices in general can malfunction or fail due to their inherent electrical sensitivity and vulnerability to physical stress. It is the responsibility of the buyer, when utilizing TOSHIBA products, to observe standards of safety, and to avoid situations in which a malfunction or failure of a TOSHIBA product could cause loss of human life, bodily injury or damage to property. In developing your designs, please ensure that TOSHIBA products are used within specified operating ranges as set forth in the most recent products specifications. Also, please keep in mind the precautions and conditions set forth in the TOSHIBA Semiconductor Reliability Handbook.
- The information contained herein is presented only as a guide for the applications of our products. No responsibility is assumed by TOSHIBA CORPORATION for any infringements of intellectual property or other rights of the third parties which may result from its use. No license is granted by implication or otherwise under any intellectual property or other rights of TOSHIBA CORPORATION or others.
- The information contained herein is subject to change without notice.

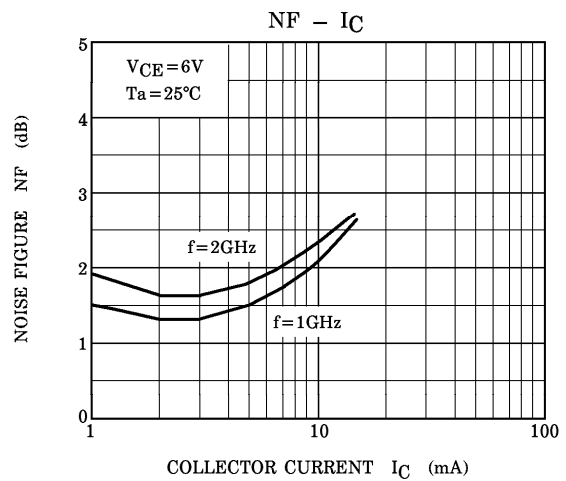
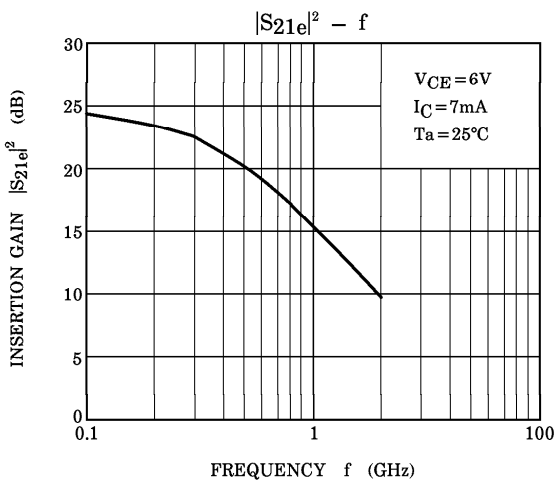
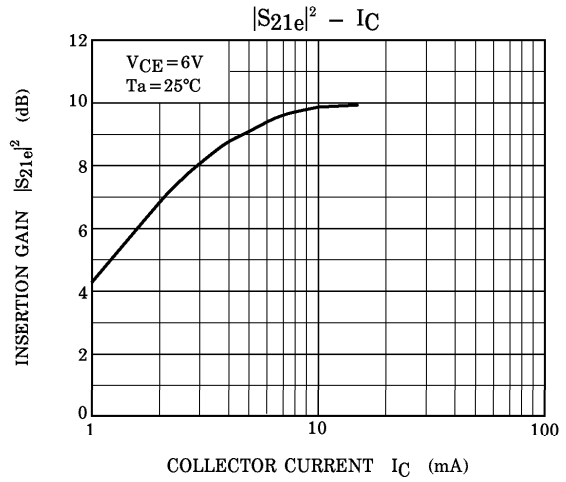
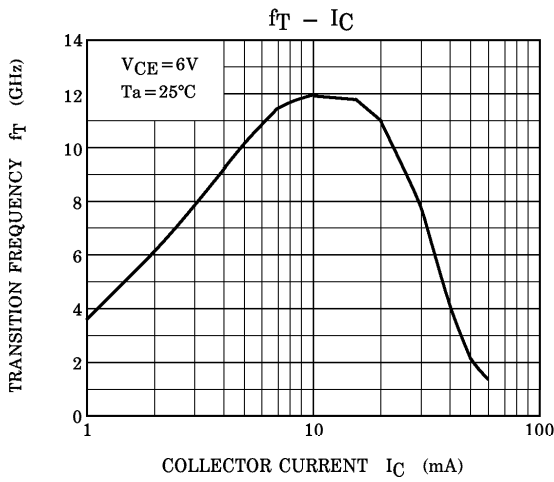
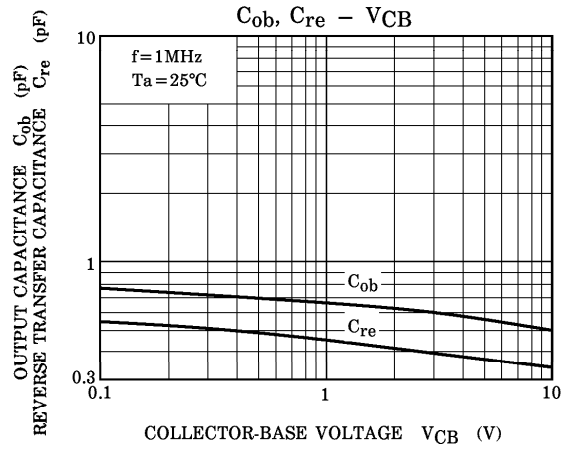
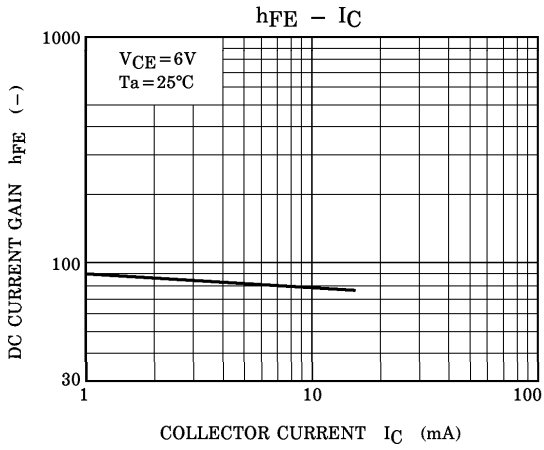

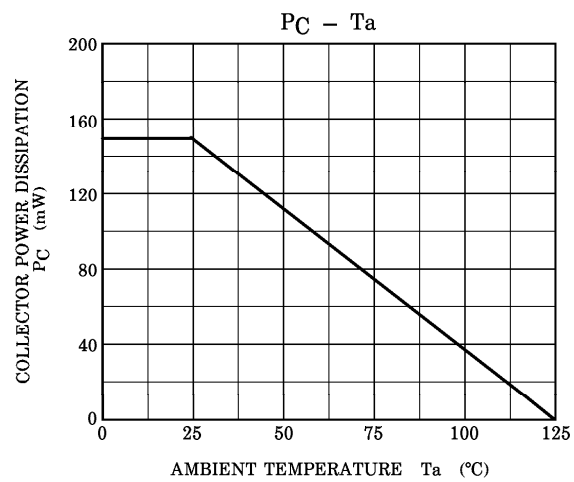
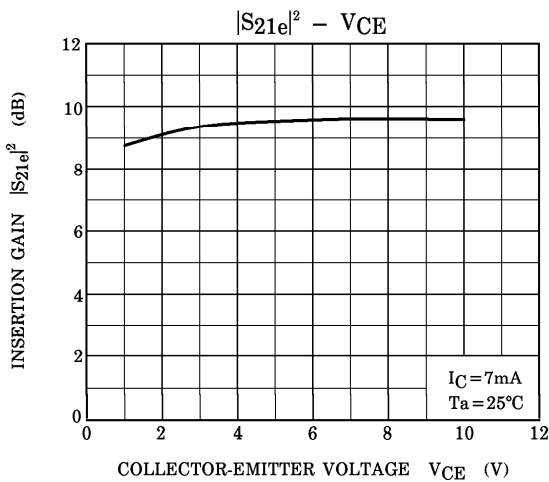

S-Parameter  $Z_0 = 50\Omega$ ,  $T_a = 25^\circ\text{C}$   
 $V_{CE} = 6\text{V}$ ,  $I_C = 3\text{mA}$

frequency (MHz)	S11		S21		S12		S22	
	Mag.	Ang.	Mag.	Ang.	Mag.	Ang.	Mag.	Ang.
200	0.831	-29.9	8.685	158.4	0.040	75.6	0.961	-20.4
400	0.744	-57.7	7.706	139.0	0.071	63.6	0.871	-38.7
600	0.653	-81.5	6.564	123.7	0.093	54.8	0.772	-54.2
800	0.565	-102.8	5.604	111.1	0.108	48.4	0.681	-67.0
1000	0.501	-121.2	4.788	101.3	0.117	45.1	0.608	-77.4
1200	0.441	-137.8	4.120	92.9	0.124	42.7	0.547	-86.4
1400	0.396	-153.1	3.583	85.9	0.129	42.0	0.496	-94.0
1600	0.363	-166.2	3.156	80.3	0.135	42.0	0.459	-100.7
1800	0.330	-179.2	2.820	75.4	0.141	42.7	0.430	-106.1
2000	0.314	-167.4	2.533	70.7	0.147	43.5	0.407	-110.8

$V_{CE} = 6\text{V}$ ,  $I_C = 10\text{mA}$

frequency (MHz)	S11		S21		S12		S22	
	Mag.	Ang.	Mag.	Ang.	Mag.	Ang.	Mag.	Ang.
200	0.696	-46.2	15.000	148.1	0.036	70.3	0.893	-29.1
400	0.570	-83.4	11.651	125.1	0.058	59.4	0.726	-50.2
600	0.488	-111.0	8.996	110.5	0.072	54.8	0.596	-64.8
800	0.432	-133.1	7.207	100.0	0.083	52.8	0.508	-76.0
1000	0.403	-150.9	5.938	91.9	0.093	53.0	0.446	-85.0
1200	0.378	-167.1	4.989	85.3	0.101	53.1	0.401	-92.9
1400	0.364	177.9	4.292	79.9	0.110	54.0	0.363	-100.0
1600	0.348	164.4	3.761	75.3	0.120	54.7	0.336	-105.7
1800	0.339	151.5	3.353	71.1	0.130	55.7	0.314	-110.2
2000	0.334	138.6	3.015	67.2	0.140	56.2	0.296	-114.1

**S<sub>11e</sub>**  
 V<sub>CE</sub> = 6V  
 I<sub>C</sub> = 3mA  
 T<sub>a</sub> = 25°C  
 (Unit : Ω)

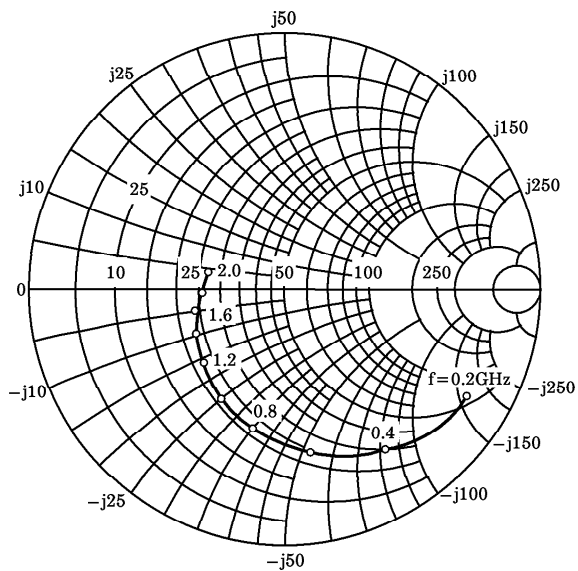

**S<sub>21e</sub>**  
 V<sub>CE</sub> = 6V  
 I<sub>C</sub> = 3mA  
 T<sub>a</sub> = 25°C

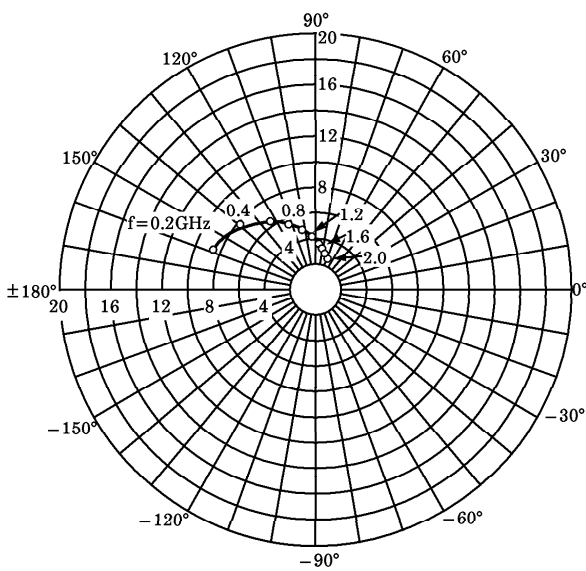

**S<sub>12e</sub>**  
 V<sub>CE</sub> = 6V  
 I<sub>C</sub> = 3mA  
 T<sub>a</sub> = 25°C

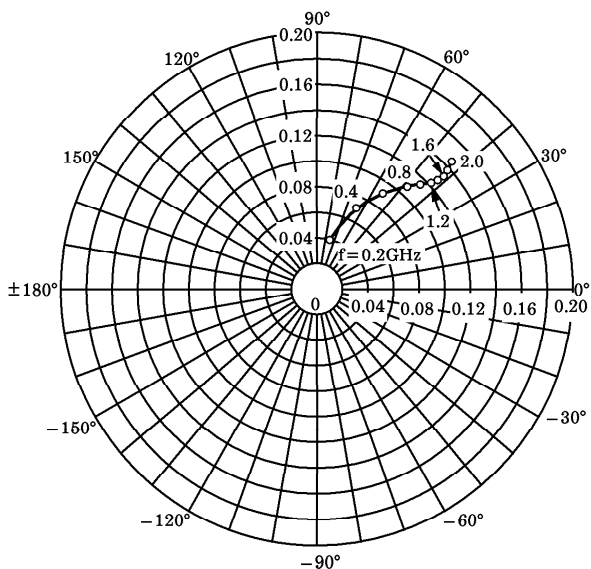

**S<sub>22e</sub>**  
 V<sub>CE</sub> = 6V  
 I<sub>C</sub> = 3mA  
 T<sub>a</sub> = 25°C  
 (Unit : Ω)

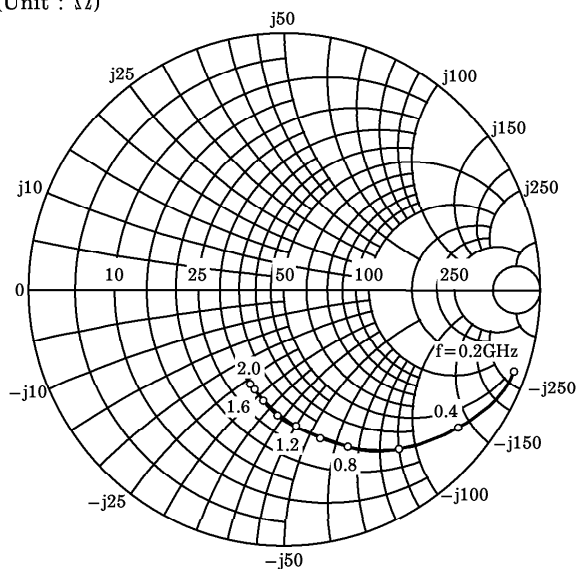

**S<sub>11e</sub>**  
 V<sub>CE</sub> = 6V  
 I<sub>C</sub> = 7mA  
 T<sub>a</sub> = 25°C  
 (Unit : Ω)

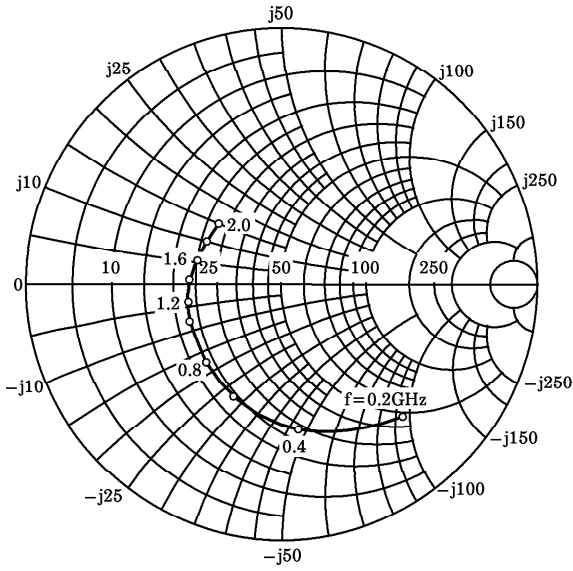

**S<sub>21e</sub>**  
 V<sub>CE</sub> = 6V  
 I<sub>C</sub> = 7mA  
 T<sub>a</sub> = 25°C

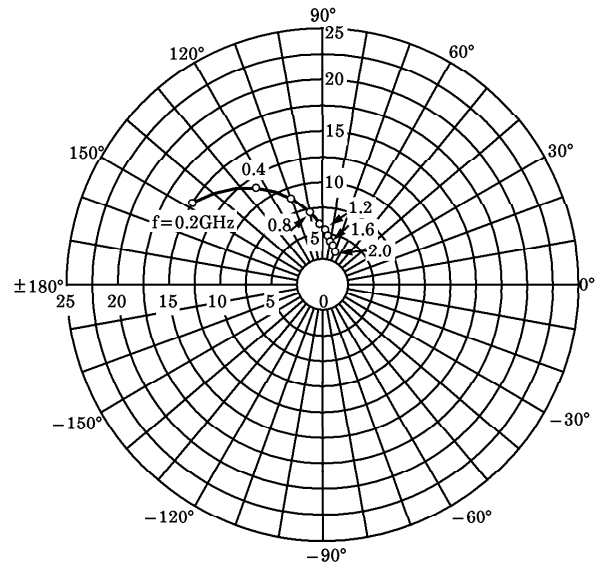

**S<sub>12e</sub>**  
 V<sub>CE</sub> = 6V  
 I<sub>C</sub> = 7mA  
 T<sub>a</sub> = 25°C

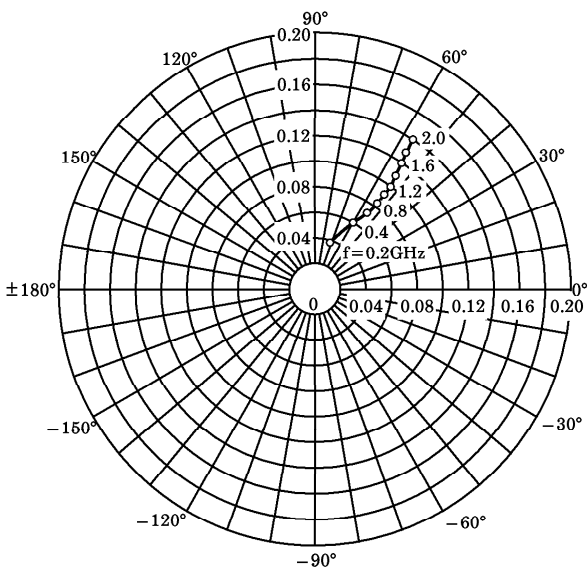

**S<sub>22e</sub>**  
 V<sub>CE</sub> = 6V  
 I<sub>C</sub> = 7mA  
 T<sub>a</sub> = 25°C  
 (Unit : Ω)

