

## DFB/EA Laser Module for 10 Gb/s Applications

### Key Features

- 1550 nm DFB CW source monolithically integrated with an Electro Absorption-modulator (EA)
- Hermetic, 7-pin butterfly package
- Single-mode fiber pigtail
- 12 GHz typical bandwidth
- -2 dBm output power
- Multisourced footprint

### Applications

- SDH STM-64 LH
- SONET OC-192 LR



### Description

The laser module, intended for OC-192/STM-64 applications, consists of a DFB laser with integrated absorption modulator mounted in a high frequency package which includes an isolator.

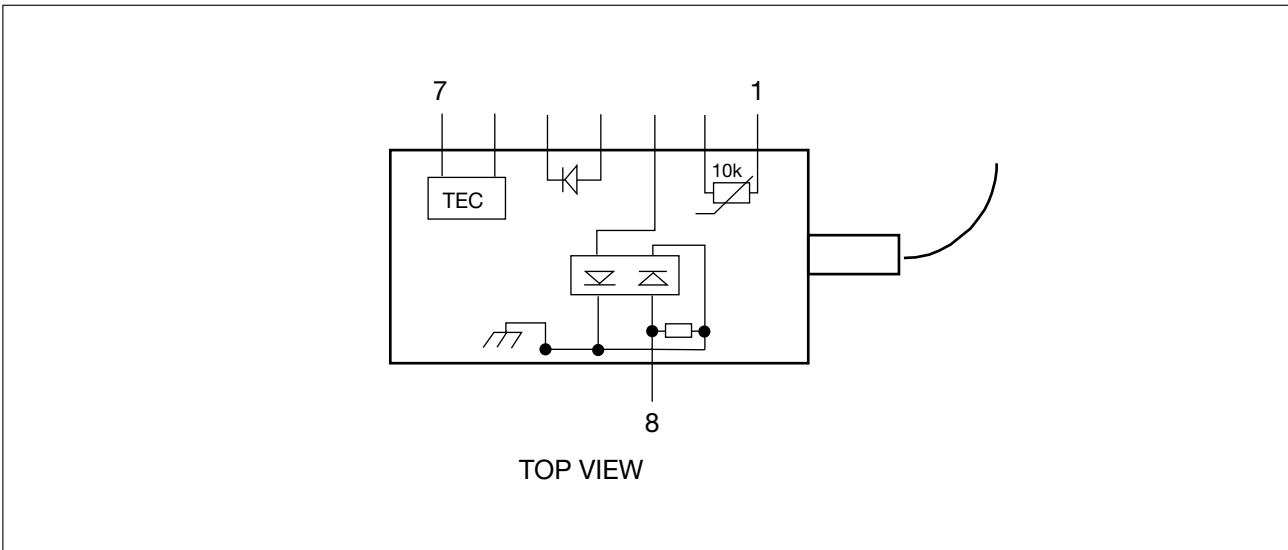

Figure 1. Block diagram

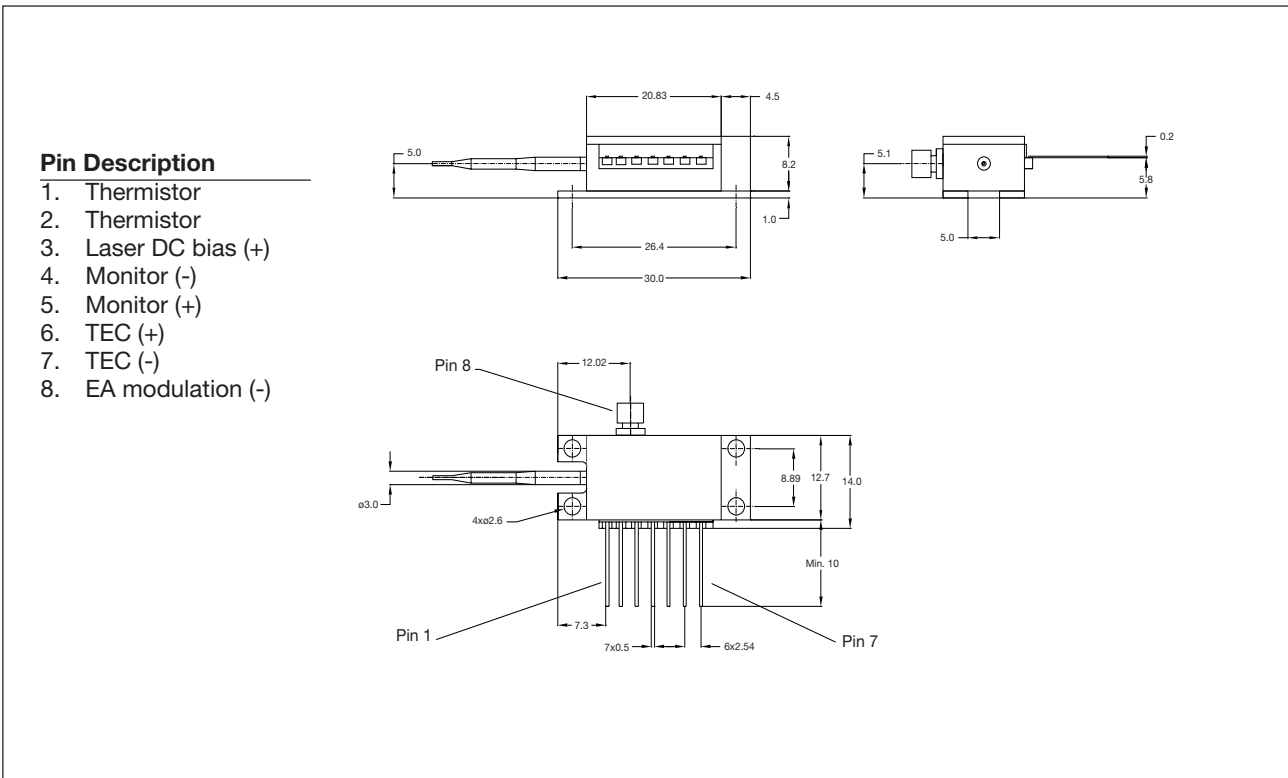

Figure 2. Pin description

## Optical Characteristics

Electrical and optical characteristics at recommended operating conditions, unless otherwise noted.

Parameter	Conditions	Symbol	Min	Typ	Max	Unit
Wavelength		$\lambda_L$	1530		1565	nm
Output power	BOL	$P_{out}$	-2			dBm
Extinction ratio	$2.5 V_{pp}$	ER	10			dB
Dispersion penalty	@ 1000 ps/nm disp.				1.5	dB
Side mode suppr. ratio		SMSR	35			dB
Optical isolation			30			dB

## Electrical Characteristics

Parameter	Conditions	Symbol	Min	Typ	Max	Unit
Operating current		$I_{op}$	50		100	mA
Threshold current		$I_{th}$			25	mA
Forward voltage		$V_f$			2	V
Reflection, $S_{11}$	0-5 GHz				-12	dB
	5-9 GHz				-9	dB
Small signal modulation bandwidth	-3 dB <sub>e</sub>	$f_c$	12			GHz
Rise/fall time	10/90 %	$t_r/t_f$			40	ps
Monitor dark current	-5 V			5	100	nA
Monitor current		$I_{Mon}$	0.1		1.0	mA
Thermistor resistance	@ 25 °C		9.5		10.5	k $\Omega$
TEC	Voltage		-2.5		2.5	V
	Current		-1.2		1.2	A
	Power				3	W

## Operating Conditions

Parameter	Symbol	Min	Typ	Max	Unit
Operating case temperature	$T_{Case}$	0		70	°C
Operating chip temperature	$T_{Op}$	20		35	°C

## Absolute Maximum Ratings

Parameter	Symbol	Min	Max	Unit
Storage temperature	$T_{Stg}$	-40	85	°C
Laser forward current	$I_{LD}$		150	mA
Modulator voltage	$V_{Mod}$	-4	1	V

**CAUTION:** Stresses outside those listed in "Absolute Maximum Ratings" may cause permanent damage to the device.

## Handling Precautions

This device may be damaged as a result of electrostatic discharge (ESD). Take proper precautions during both handling and testing. This typically includes grounded wrist wraps, workbenches and floor mats in ESD controlled areas. Semiconductor devices may be damaged by current surges, use appropriate transient protection.

## Quality Assurance

Ericsson Microelectronics commitment to quality has been proven through a decade of semiconductor device production and has been confirmed to ISO 9001. Opto product qualification is made according to the intention of applicable Telcordia standards.

## Connector Options

FC/PC

SC

(Other connectors available on request)



Information given in this data sheet is believed to be accurate and reliable. However no responsibility is assumed for the consequences of its use nor for any infringement of patents or other rights of third parties which may result from its use. No license is granted by implication or otherwise under any patent or patent rights of Ericsson Microelectronics. These products are sold only according to Ericsson Microelectronics' general conditions of sale, unless otherwise confirmed in writing.

Product specifications subject to change without notice.

Ericsson Microelectronics AB  
SE-164 81 Kista, Sweden  
Telephone: +46 8 757 50 00  
[www.ericsson.com/microelectronics](http://www.ericsson.com/microelectronics)

For local sales contacts, please refer to our website  
or call: Int + 46 8 757 47 00, Fax: +46 8 757 47 76

1522-PGT 204 05 Rev. E  
© Ericsson Microelectronics AB, October 2000