

TOSHIBA FIELD EFFECT TRANSISTOR SILICON P CHANNEL MOS TYPE

# 2SJ342

HIGH SPEED SWITCHING APPLICATIONS

ANAROG SWITCH APPLICATIONS

- Low Threshold Voltage :  $V_{th} = -0.8 \sim -2.5V$
- High Speed
- Enhancement-Mode
- Small Package
- Complementary to 2SK1825

MAXIMUM RATINGS ( $T_a = 25^\circ C$ )

CHARACTERISTIC	SYMBOL	RATING	UNIT
Drain-Source Voltage	$V_{DS}$	-50	V
Gate-Source Voltage	$V_{GSS}$	-7	V
DC Drain Current	$I_D$	-50	mA
Drain Power Dissipation	$P_D$	300	mW
Channel Temperature	$T_{ch}$	150	$^\circ C$
Storage Temperature Range	$T_{stg}$	-55~150	$^\circ C$

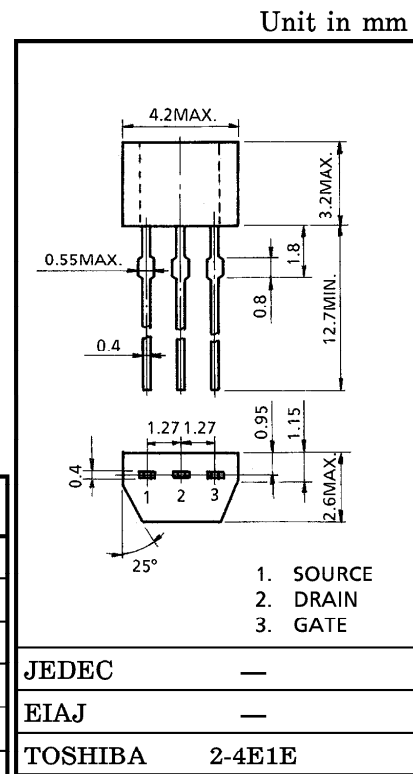

Weight : 0.13g

ELECTRICAL CHARACTERISTICS ( $T_a = 25^\circ C$ )

CHARACTERISTIC	SYMBOL	TEST CONDITION	MIN.	TYP.	MAX.	UNIT
Gate Leakage Current	$I_{GSS}$	$V_{GS} = -7V, V_{DS} = 0$	—	—	-1	$\mu A$
Drain-Source Breakdown Voltage	$V_{(BR) DSS}$	$I_D = -100\mu A, V_{GS} = 0$	-50	—	—	V
Drain Cut-off Current	$I_{DSS}$	$V_{DS} = -50V, V_{GS} = 0$	—	—	-1	$\mu A$
Gate Threshold Voltage	$V_{th}$	$V_{DS} = -5V, I_D = -0.1mA$	-0.8	—	-2.5	V
Forward Transfer Admittance	$ Y_{fs} $	$V_{DS} = -5V, I_D = -10mA$	15	—	—	mS
Drain-Source ON Resistance	$R_{DS(ON)}$	$I_D = -10mA, V_{GS} = -4V$	—	20	50	$\Omega$
Input Capacitance	$C_{iss}$	$V_{DS} = -5V, V_{GS} = 0, f = 1MHz$	—	10.5	—	pF
Reverse Transfer Capacitance	$C_{rss}$	$V_{DS} = -5V, V_{GS} = 0, f = 1MHz$	—	1.9	—	pF
Output Capacitance	$C_{oss}$	$V_{DS} = -5V, V_{GS} = 0, f = 1MHz$	—	7.2	—	pF
Switching Time	Turn-on Time	$t_{on}$	—	0.15	—	$\mu s$
	Turn-off Time	$t_{off}$	—	0.13	—	

961001EAA2

● TOSHIBA is continually working to improve the quality and the reliability of its products. Nevertheless, semiconductor devices in general can malfunction or fail due to their inherent electrical sensitivity and vulnerability to physical stress. It is the responsibility of the buyer, when utilizing TOSHIBA products, to observe standards of safety, and to avoid situations in which a malfunction or failure of a TOSHIBA product could cause loss of human life, bodily injury or damage to property. In developing your designs, please ensure that TOSHIBA products are used within specified operating ranges as set forth in the most recent products specifications. Also, please keep in mind the precautions and conditions set forth in the TOSHIBA Semiconductor Reliability Handbook.

EQUIVALENT CIRCUIT

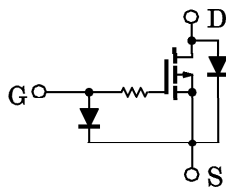

SWITCHING TIME TEST CIRCUIT

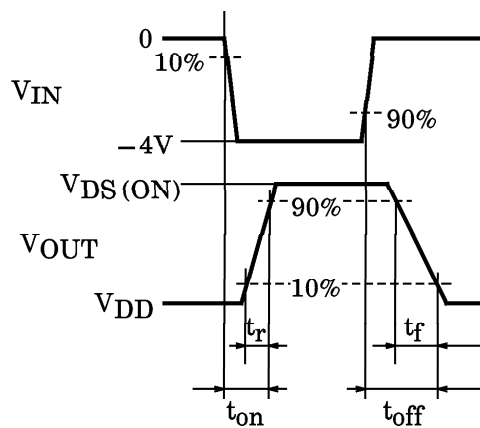
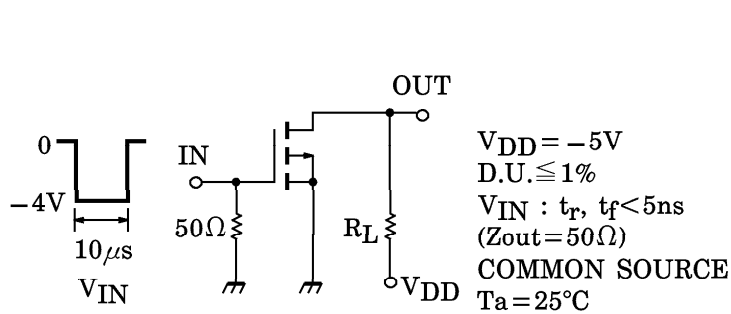

961001EAA2'

- The information contained herein is presented only as a guide for the applications of our products. No responsibility is assumed by TOSHIBA CORPORATION for any infringements of intellectual property or other rights of the third parties which may result from its use. No license is granted by implication or otherwise under any intellectual property or other rights of TOSHIBA CORPORATION or others.
- The information contained herein is subject to change without notice.

