

**Audio/Video Switch with Electronic Volume for 3 Scart**

**Description**

The CXA2125Q is an I<sup>2</sup>C programmable audio, video switch designed primarily for set top box applications. It interfaces from digital encoder sources to TV, VCR and auxiliary scart connectors.

**Features**

- 3 scart independent audio/video switching (TV, VCR, AUX)
- 0 to -63dB volume control with click noise reduction
- 5 stereo audio inputs
- I<sup>2</sup>C control
- Scart Function Switching input and output
- Scart Fast Blanking for OSD
- Mono switchable to stereo on TV, VCR and AUX outputs
- On-chip +12V to +9V voltage regulator
- Logic output
- Selectable +6dB, +12dB gain on TV output
- RGB input on VCR scart
- Compatible with 2 scart Audio/Video switch CXA2126Q

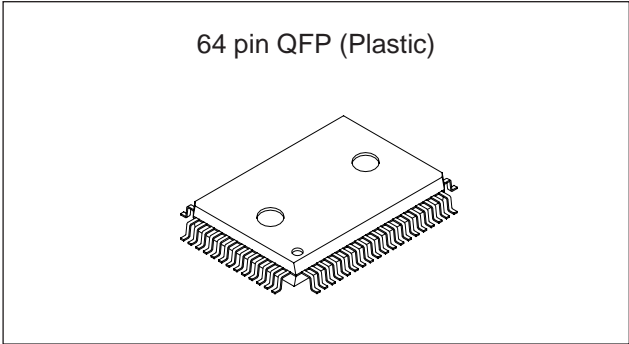

**Applications**

Digital Set Top Box

**Structure**

Bipolar silicon monolithic IC

**Absolute Maximum Ratings**

• Supply voltage	V <sub>CC</sub>	12	V
• Operating temperature	T <sub>opr</sub>	-20 to +75	°C
• Storage temperature	T <sub>stg</sub>	-65 to +150	°C
• Allowable power dissipation	P <sub>D</sub>	850	mW

**Operating Conditions**

• Supply voltage	10.7 to 12	V
• Operating voltage	9 ± 0.5	V

Sony reserves the right to change products and specifications without prior notice. This information does not convey any license by any implication or otherwise under any patents or other right. Application circuits shown, if any, are typical examples illustrating the operation of the devices. Sony cannot assume responsibility for any problems arising out of the use of these circuits.

Block Diagram

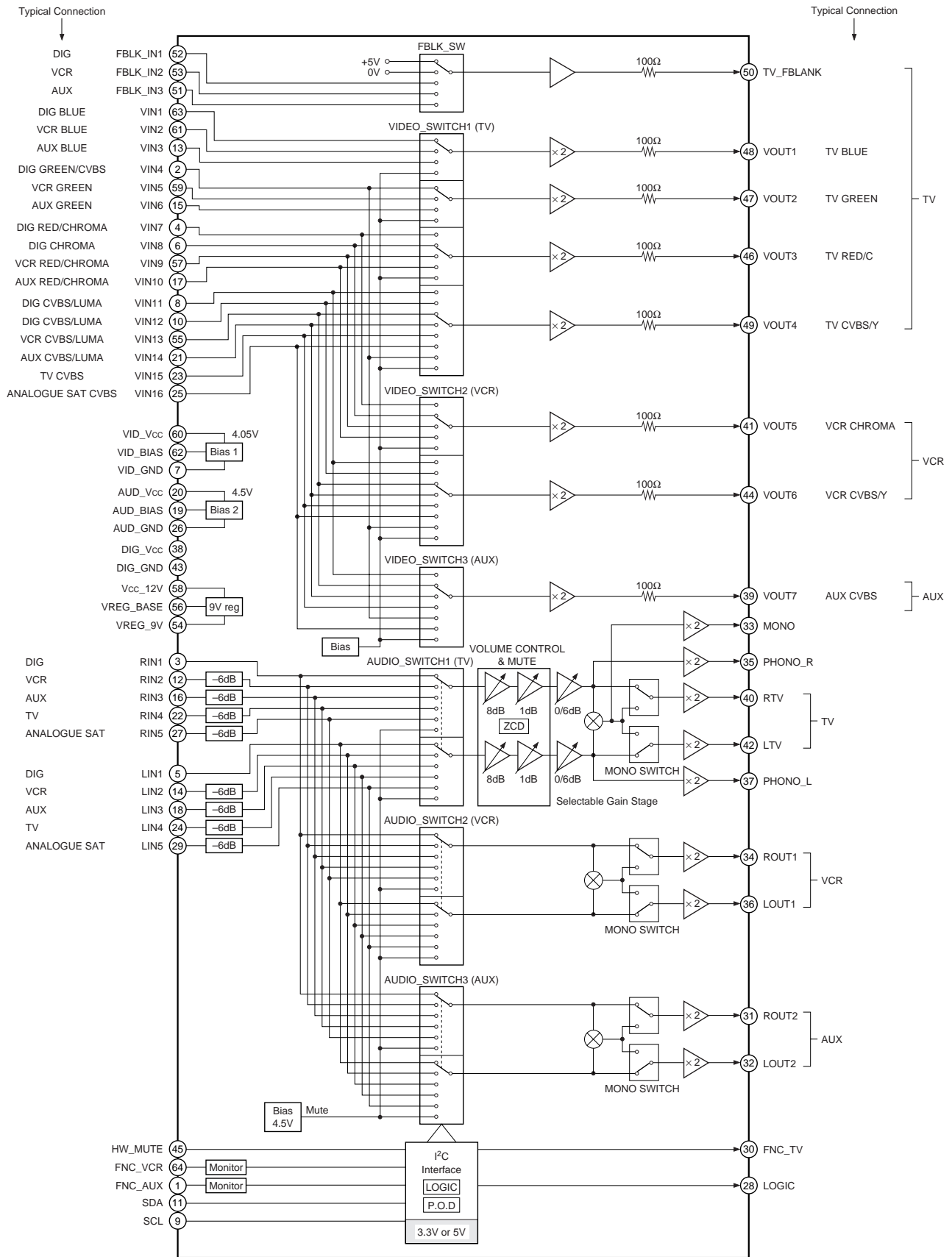

Pin Configuration

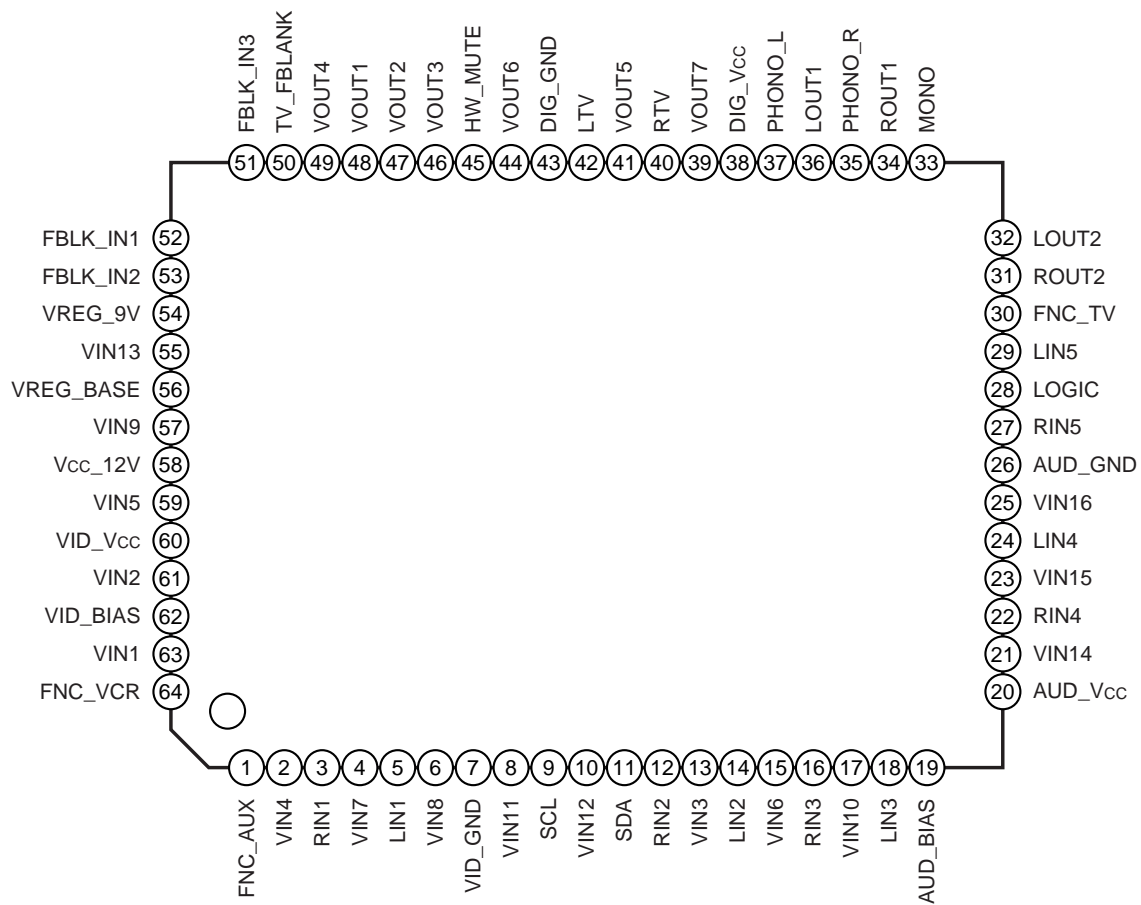

Pin Description

Pin No.	Symbol	Pin voltage	Equivalent circuit	Description
63 61 13 2 59 15 4 6 57 17 8 10 55 21 23 25	VIN1 VIN2 VIN3 VIN4 VIN5 VIN6 VIN7 VIN8 VIN9 VIN10 VIN11 VIN12 VIN13 VIN14 VIN15 VIN16	4.6V		Video signal inputs. An input coupling capacitor is required. (typ = 0.47μF)
12 16 22 27 14 18 24 29	RIN2 RIN3 RIN4 RIN5 LIN2 LIN3 LIN4 LIN5	4.5V		Audio signal inputs. An input coupling capacitor is required. (typ = 2.2μF)
48 47 46 49 41 44 39	VOUT1 VOUT2 VOUT3 VOUT4 VOUT5 VOUT6 VOUT7	3.9V		Video signal outputs.

Pin No.	Symbol	Pin voltage	Equivalent circuit	Description
40 34 31 42 36 32 35 37 33	RTV ROUT1 ROUT2 LTV LOUT1 LOUT2 PHONO_R PHONO_L MONO	4.5V		Audio signal outputs. A coupling capacitor may be used. (typ = 10μF)
62	BIAS_VIDEO	3.9V		Reference Bias for video circuit. Connected to GND with capacitor. (typ = 47μF)
19	BIAS_AUDIO	4.5V		Reference Bias for audio circuit. Connected to GND with capacitor. (typ = 22μF)
30	FNC_TV	—		I <sup>2</sup> C controlled output giving 0V, 6V or 12V.

Pin No.	Symbol	Pin voltage	Equivalent circuit	Description
54	VREG_9V	9V		Pin connected to emitter of external regulator transistor.
56	VREG_BASE	9.7V		Connection to base of external regulator transistor. Max I = 1mA
9	SCL	—		I <sup>2</sup> C clock input.
11	SDA	—		I <sup>2</sup> C data input/output.

Pin No.	Symbol	Pin voltage	Equivalent circuit	Description
45	HW_MUTE	—		HW MUTE: This pin is active high > 2.5V < 9V. When high, all audio muted.
28	LOGIC	—		Open collector logic pins.
50	FBLK_OUT	—		Fast Blank output set by I <sup>2</sup> C to input FBLK_IN1, FBLK_IN2, or FBLK_IN3. High = 5.3V Low = 1.2V Connected to external emitter follower.
52 53 51	FBLK_IN1 FBLK_IN2 FBLK_IN3	—		Fast Blank inputs. Low = < 0.4V High = > 1.0V, < 3.0V

Pin No.	Symbol	Pin voltage	Equivalent circuit	Description
64 1	FNC_VCR FNC_AUX	—		Function switching input. (Scart pin 8)
3 5	RIN1 LIN1	4.5V		Audio signal inputs. A coupling capacitor is required for these inputs. (typ = 2.2µF)



**Electrical Characteristics**

Nominal conditions (Ta = 25°C)

Item	Symbol	Conditions	Min.	Typ.	Max.	Unit
Current consumption	I <sub>CC</sub>	V <sub>CC_12V</sub> = 12V, No signal, no load	30	50	80	mA

**Video system**

Nominal conditions (Ta = 25°C, V<sub>CC\_12V</sub> = 12V, V<sub>REG\_9V</sub> = 9V)

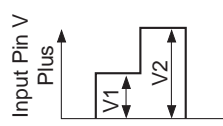
Item	Symbol	Conditions	Min.	Typ.	Max.	Unit
Input pin voltage	V <sub>VPin</sub>	No signal, no load (Fig.1)	4.3	4.6	4.9	V
Output pin voltage – with output on.	V <sub>VPout1</sub>	No signal, no load (Fig.1)	3.6	3.9	4.2	V
Output pin voltage – with output off.	V <sub>VPout2</sub>	No signal, no load (Fig.1)	—	0	0.2	V
Gain	GV <sub>v</sub>	f = 200kHz, 0.3Vp-p input (Fig.2)	5.5	6.0	6.5	dB
Bandwidth	f <sub>V3dB</sub>	0.3Vp-p input, frequency where output level is –3dB with 200kHz serving as 0dB (Fig. 2)	15	20	—	MHz
Input dynamic range	V <sub>DRVI</sub>	200kHz input (Fig.2)	2.5	—	—	Vp-p
Output dynamic range	V <sub>DRVO</sub>	200kHz, 2.5Vp-p input (Fig.2)	5.0	—	—	Vp-p
Cross talk	V <sub>ctv</sub>	f = 4.43MHz, 1Vp-p input (Fig.2)	—	—	–50	dB
S/N ratio	S/N <sub>v</sub>	Ratio of 0.7Vp-p white video signal to "black line" noise. Weighted using CCIR 567. HPF @5kHz, LPF @5MHz. (Fig.2)	—	72	—	dB
Input impedance	Z <sub>inv</sub>	1V <sub>rms</sub> 1kHz input through 56kΩ. Attenuation measured to calculate Z <sub>inv</sub> (Fig.3)	94	120	175	kΩ
Non-linearity	Lin	 <p>(Fig.4)</p> <p>V<sub>1</sub> = Pin voltage +0.5V,  V<sub>2</sub> = Pin voltage +1V  At output, non-linearity = <math>\left(\frac{V_2}{V_1 \times 2} - 1\right) \times 100</math></p>	–3	–0.4	3	%
Differential gain	DG	1.7Vp-p 5-step modulated staircase. (Chroma and Burst are 150mVp-p 4.43MHz) (Fig.2)	–3	1.5	2	%
Differential phase	DP	as above. (Fig.2)	–3	1	2	Deg
Sync crush	SC	Percentage reduction in sync pulse (0.4Vp-p), with tip at –1.2V input offset. (Fig.4)	–2	0	2	%

**Audio system**

Unless otherwise stated: input coupling capacitor 1 $\mu$ F; output coupling capacitor of 10 $\mu$ F; load of 10k $\Omega$ .

Nominal conditions (Ta = 25°C, Vcc\_12V = 12V, VREG\_9V = 9V)

Item	Symbol	Conditions	Min.	Typ.	Max.	Unit
Input/output pin voltage	V <sub>APIN</sub>	No signal, no load (Fig. 5)	4.2	4.5	4.8	V
Gain Input	Output					
RIN1/LIN1	TV/Phono	G <sub>VA1</sub> f = 1kHz, 0.5Vrms input. TV output amplifier set to 0dB (Fig. 6)	5.5	6	6.5	dB
RIN1/LIN1	TV/Phono	G <sub>VA2</sub> f = 1kHz, 0.5Vrms input. TV output amplifier set to +6dB (Fig. 6)	11	12	13	dB
RIN1/LIN1	VCR/AUX	G <sub>VA3</sub> f = 1kHz, 1Vrms input. (Fig. 6)	—	6	—	dB
RIN1 + LIN1	TV mono	G <sub>VA4</sub> f = 1kHz, 0.5Vrms stereo input. TV output amplifier set to 0dB (Fig. 6)	—	6	—	dB
RIN1 + LIN1	TV mono	G <sub>VA5</sub> f = 1kHz, 0.5Vrms stereo input. TV output amplifier set to +6dB (Fig. 6)	—	12	—	dB
RIN1 + LIN1	VCR mono AUX mono	G <sub>VA6</sub> f = 1kHz, 0.5Vrms stereo input. (Fig. 6)	—	6	—	dB
RIN2, 3, 4, 5 LIN2, 3, 4, 5	TV/Phono	G <sub>VA7</sub> f = 1kHz, 1Vrms input. TV output amplifier set to 0dB (Fig. 6)	-0.5	0	+0.5	dB
RIN2, 3, 4, 5 LIN2, 3, 4, 5	TV/Phono	G <sub>VA8</sub> f = 1kHz, 1Vrms input. TV output amplifier set to +6dB (Fig. 6)	5.5	6	6.5	dB
RIN2, 3, 4, 5 + LIN2, 3, 4, 5	TV mono	G <sub>VA9</sub> f = 1kHz, 1Vrms stereo input. TV output amplifier set to 0dB (Fig. 6)	-0.7	0	+0.3	dB
RIN2, 3, 4, 5 + LIN2, 3, 4, 5	TV mono	G <sub>VA10</sub> f = 1kHz, 1Vrms stereo input. TV output amplifier set to +6dB (Fig. 6)	5	6	7	dB
RIN2, 3, 4, 5 LIN2, 3, 4, 5	VCR/AUX	G <sub>VA11</sub> f = 1kHz, 1Vrms input. (Fig. 6)	-0.5	0	+0.5	dB
RIN2, 3, 4, 5 + LIN2, 3, 4, 5	VCR mono AUX mono	G <sub>VA12</sub> f = 1kHz, 1Vrms stereo input. (Fig. 6)	-0.7	0	+0.3	dB
Audio frequency response	F <sub>AF</sub>	0.3Vp-p input. Output level at 30kHz with 1kHz serving as 0dB. (Fig. 7)	-0.3	0	+0.3	dB
Frequency B/W	F <sub>BWA1</sub>	0.3Vp-p input; frequency where output level is -3dB with 1kHz serving as 0dB. No load (Fig. 7)	—	1	—	MHz
Distortion	THD	f = 1kHz, 0.5Vrms, unweighted response; LPF @400Hz, HPF @80kHz. (Fig. 6)	—	0.003	0.2	%
Input dynamic range RIN2, 3, 4, 5 LIN2, 3, 4, 5	V <sub>dA1</sub>	f = 1kHz (Fig. 6)	2	—	—	Vrms
Input dynamic range RIN1 LIN1	V <sub>dA2</sub>	f = 1kHz (Fig. 6)	1	—	—	Vrms
Cross talk (Channel separation)	V <sub>ctA</sub>	f = 1kHz, 1Vrms input on one input, measure on any other audio output. (Fig.6)	—	—	-76	dB

Item	Symbol	Conditions	Min.	Typ.	Max.	Unit
DC offset	Voff	Offset voltage between input and output (Fig. 5)	-30	—	+30	mV
Input impedance RIN2, 3, 4, 5 LIN2, 3, 4, 5	Zin1	(excluding any external series resistor)	—	66	—	kΩ
Input impedance RIN1/LIN1	Zin2	(excluding any external series resistor)	—	33	—	kΩ
Output impedance	Zout	(excluding any external series resistor)	—	10	—	Ω
Phase difference	Vpda	f = 1kHz, 1Vrms input to two channels. Phase difference of stereo output measured	—	0.05	—	Deg
S/N ratio	S/NA	f = 1kHz, 1Vrms input (at maximum volume). HPF @20Hz, LPF@20kHz. (Fig. 6)	80	90	—	dB
<b>Electronic Volume Control</b>						
Fine volume attenuation step	A <sub>EVC</sub>	f = 1kHz, 0.5Vrms input. Set by I <sup>2</sup> C. (Fig.6)	0.6	1	1.4	dB
Coarse volume attenuation step	A <sub>EVF</sub>	f = 1kHz, 0.5Vrms input. Set by I <sup>2</sup> C. (Fig.6)	7.5	8	8.5	dB
Mute	Amute	f = 1kHz, 1Vrms input. (Fig.6)	—	—	-80	dB
DC Offset -RTV, LTV	VoffTV	Offset voltage between any audio input and RTV, LTV outputs. (Fig.5)	-30	0	+30	mV

I<sup>2</sup>C Electrical Characteristics

Nominal conditions (Ta = 25°C, Vcc\_12V = 12V, VREG\_9V = 9V)

Item	Symbol	Conditions	Min.	Typ.	Max.	Unit
High level input voltage	V <sub>IH</sub>		2.3	—	5.0	V
Low level input voltage	V <sub>IL</sub>		0	—	1.5	V
Low level output voltage	V <sub>OL</sub>	With SDA, 3mA current supplied	0	—	0.4	V
Maximum clock frequency	f <sub>SCL</sub>		0	—	100	kHz
Minimum waiting time for data change	t <sub>BUF</sub>		4.5	—	—	μs
Minimum waiting time for data transfer start	t <sub>HD;STA</sub>		4.0	—	—	μs
Low level clock pulse width	t <sub>LOW</sub>		4.7	—	—	μs
High level clock pulse width	t <sub>HIGH</sub>		4.0	—	—	μs
Minimum waiting time for start preparation	t <sub>SU;STA</sub>		4.7	—	—	μs
Minimum data hold time	t <sub>HD;DAT</sub>		5	—	—	s
Minimum data preparation time	t <sub>SU;DAT</sub>		250	—	—	ns
Rise time	t <sub>R</sub>		—	—	1	μs
Fall time	t <sub>F</sub>		—	—	300	ns
Minimum waiting time for stop preparation	t <sub>SU;STO</sub>		4.7	—	—	μs

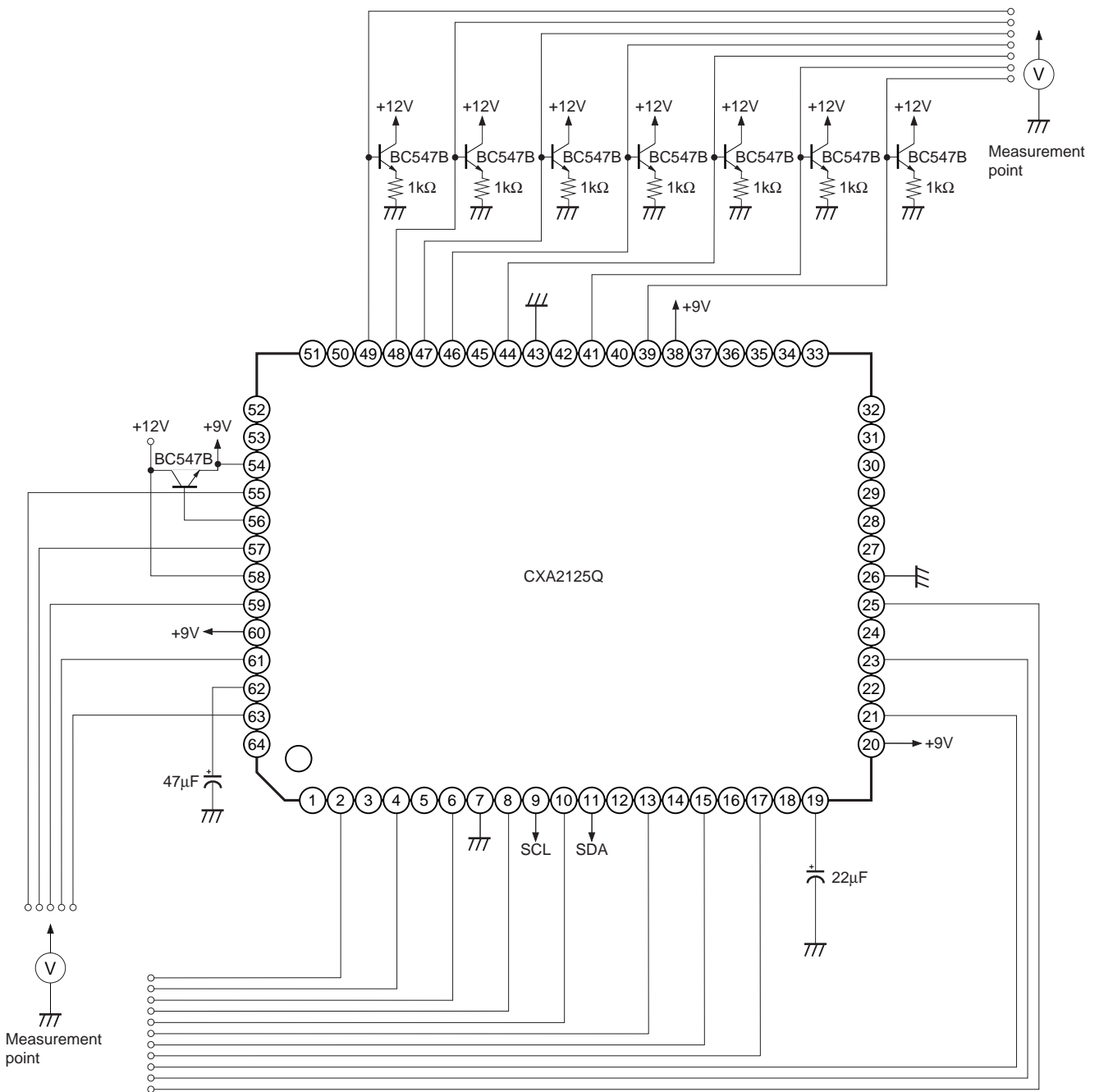
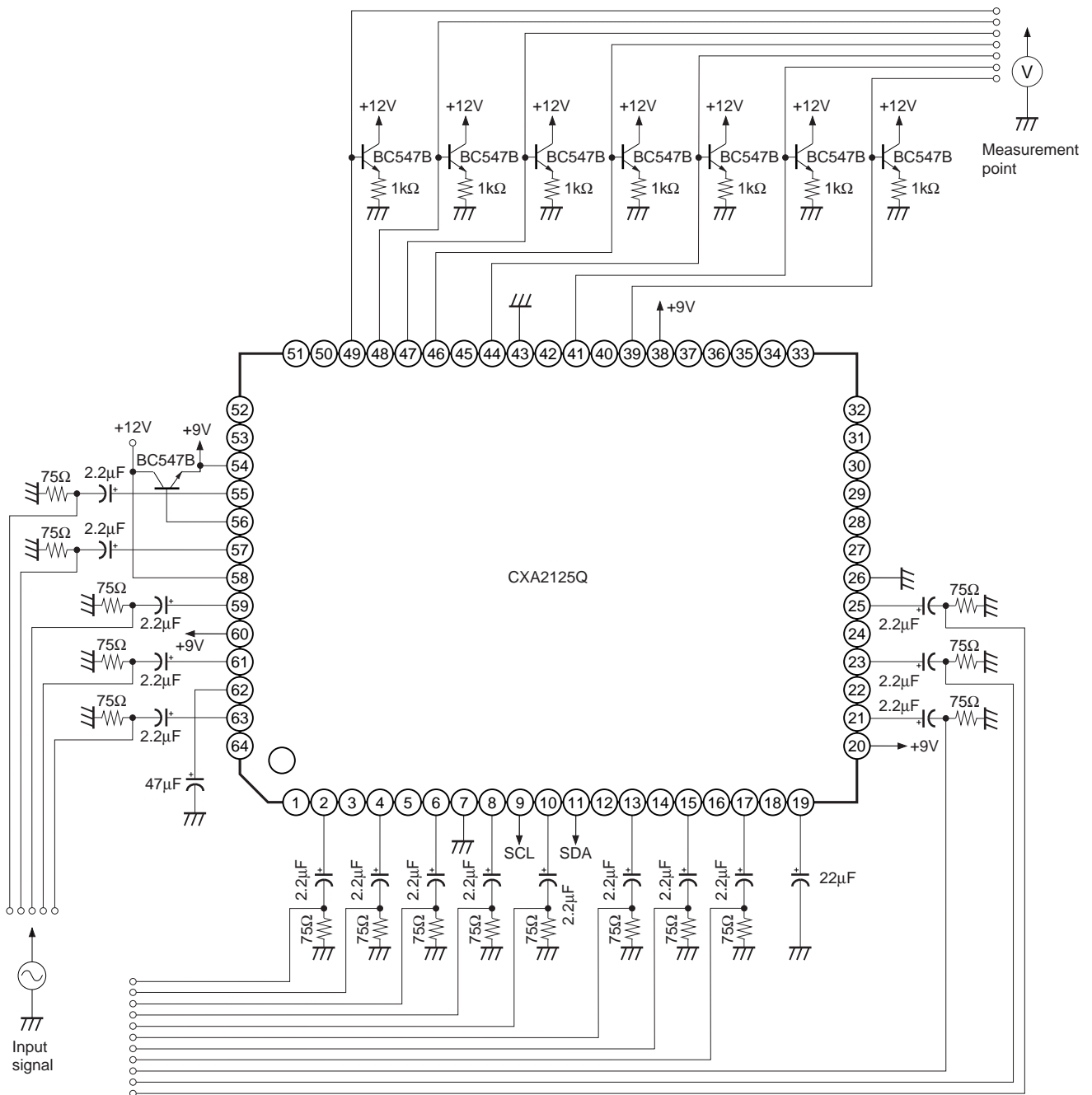

Fig. 1. Video system (d.c. test)

d.c. measured from pins: 2, 4, 6, 8, 10, 13, 15, 17, 21, 23, 25, 39, 41, 44, 46, 47, 48, 49, 55, 57, 59, 61, 63

- Notes)**
1. All +9V supplies de-coupled close to supply pins, 20, 38, 60 with 10nF ceramic capacitor.
  2. All video outputs are loaded with emitter follower during tests.

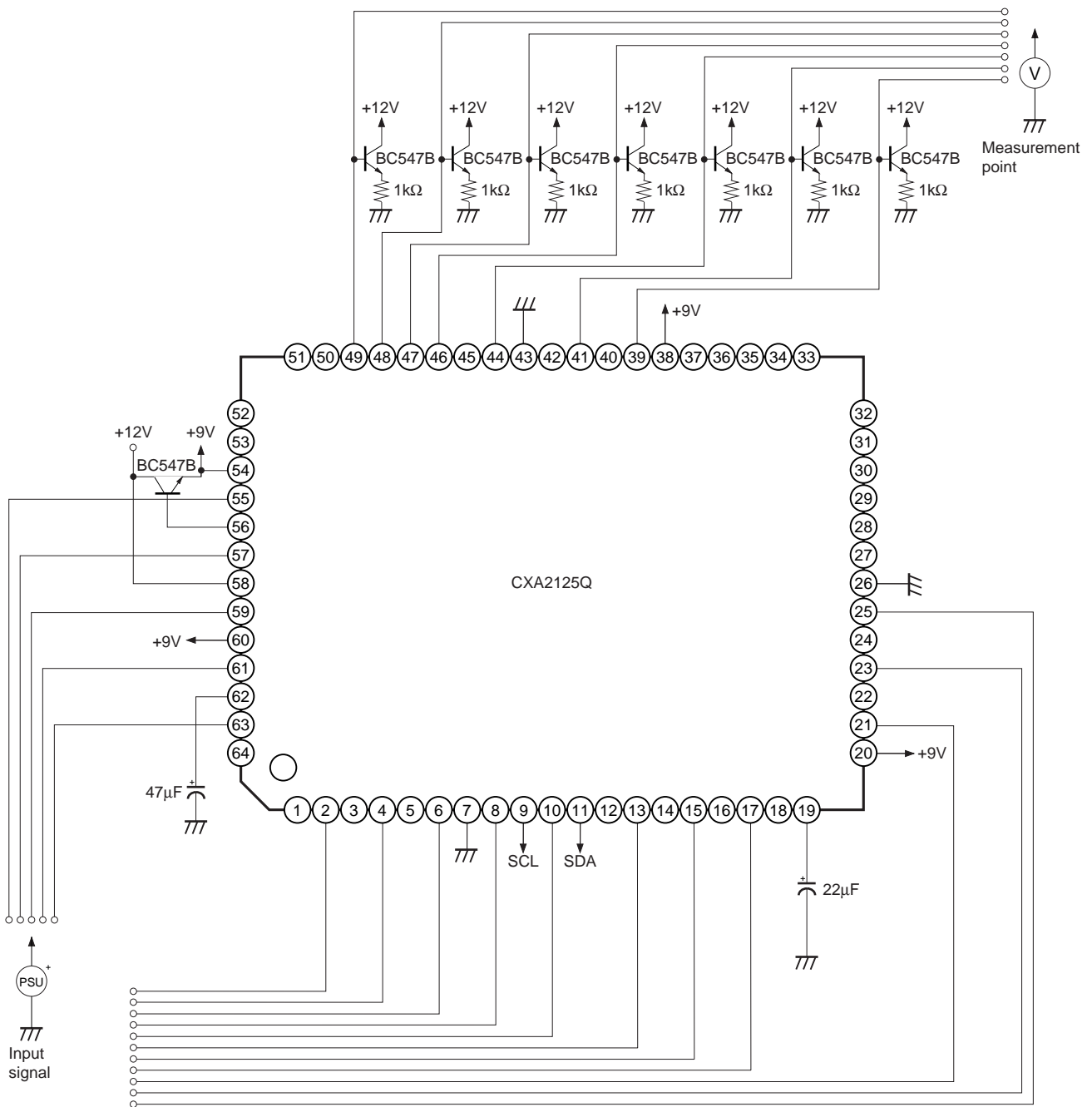

**Fig. 2. Video system (gain, dynamic range, bandwidth, differential gain, differential phase, crosstalk, signal to noise)**

Signal applied to Pins 2, 4, 6, 8, 10, 13, 15, 17, 21, 23, 25, 55, 57, 59, 61, 63  
 Output signal measured from Pins 39, 41, 44, 46, 47, 48, 49

- Notes)**
1. All +9V supplies de-coupled close to supply pins, 20, 38, 60 with 10nF ceramic capacitor.
  2. For tests requiring video measuring equipment with 75Ω input impedance, an external video line driver or buffer is used.
  3. All video outputs are loaded with emitter follower during tests.





**Fig. 4. Video system (linearity)**

Signal applied to Pins 2, 4, 6, 8, 10, 13, 15, 17, 21, 23, 25, 55, 57, 59, 61, 63  
 Output signal measured from Pins 39, 41, 44, 46, 47, 48, 49

- Notes)**
1. All +9V supplies de-coupled close to supply pins, 20, 38, 60 with 10nF ceramic capacitor.
  2. All video outputs are loaded with emitter follower during tests.



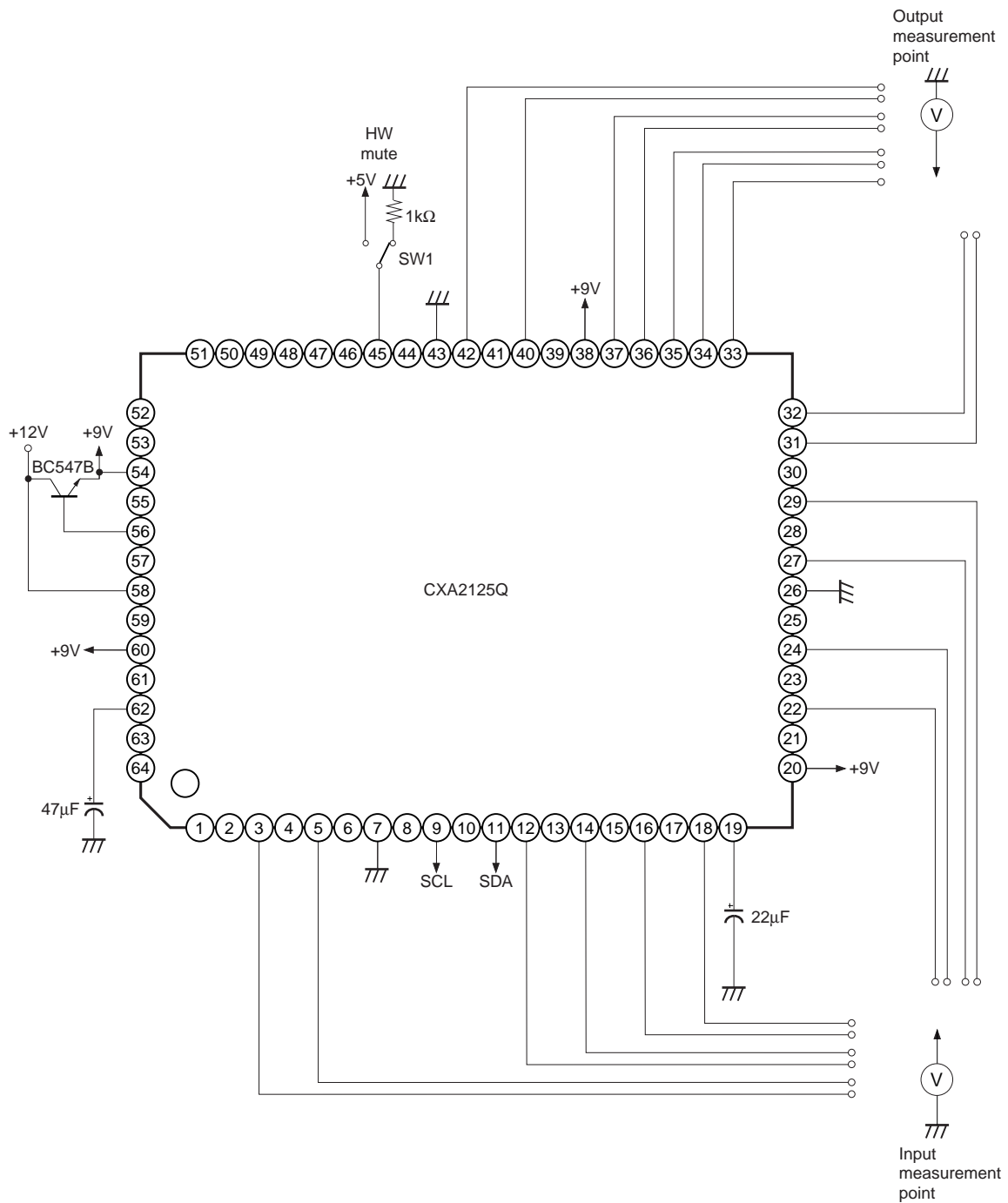
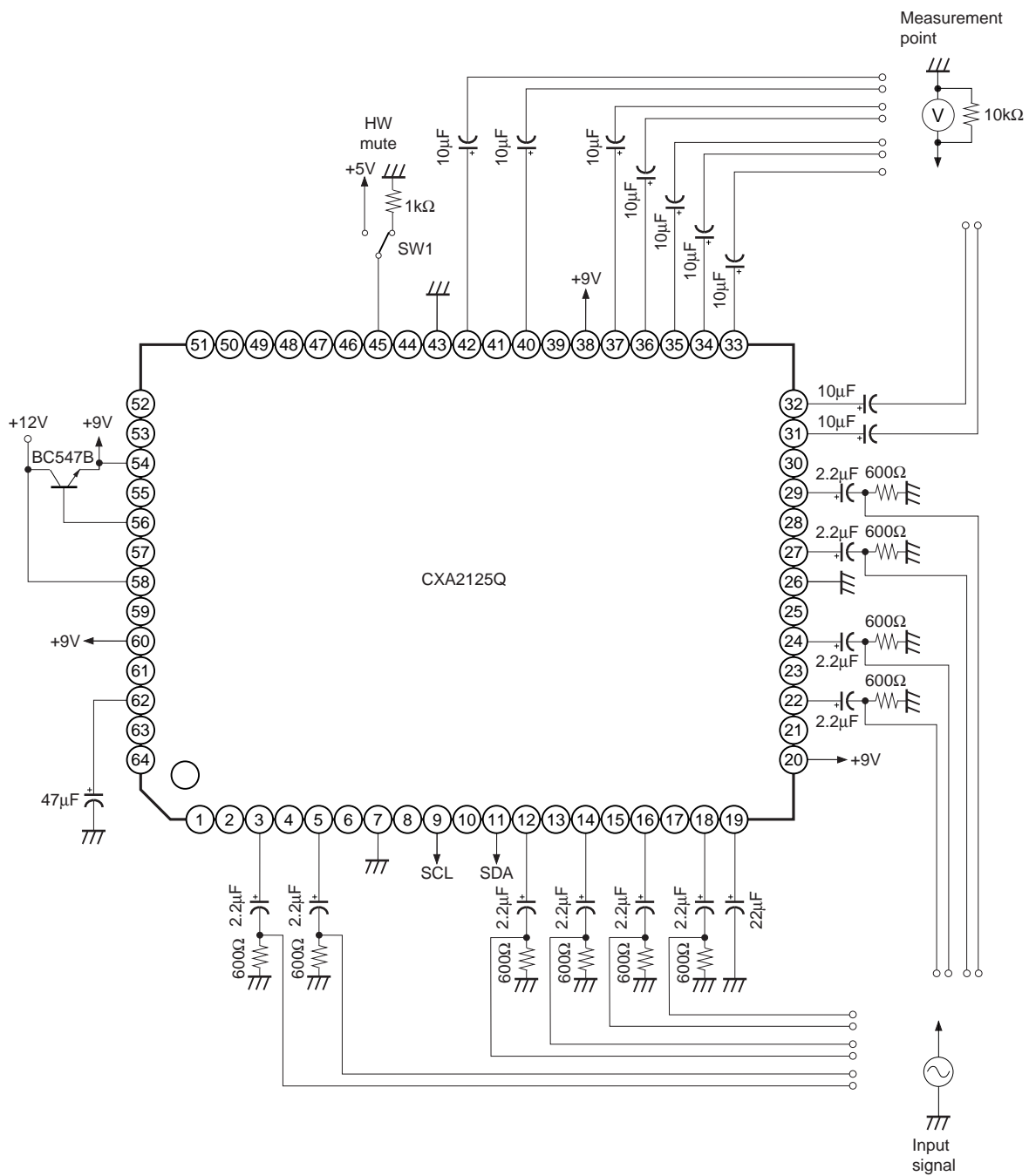

Fig. 5. Audio system (d.c. tests)

d.c. measured from pins: 3, 5, 12, 14, 16, 18, 22, 24, 27, 29, 31, 32, 33, 34, 35, 36, 37, 40, 42

**Note)** All +9V supplies de-coupled close to supply pins, 20, 38, 60 with 10nF ceramic capacitor.

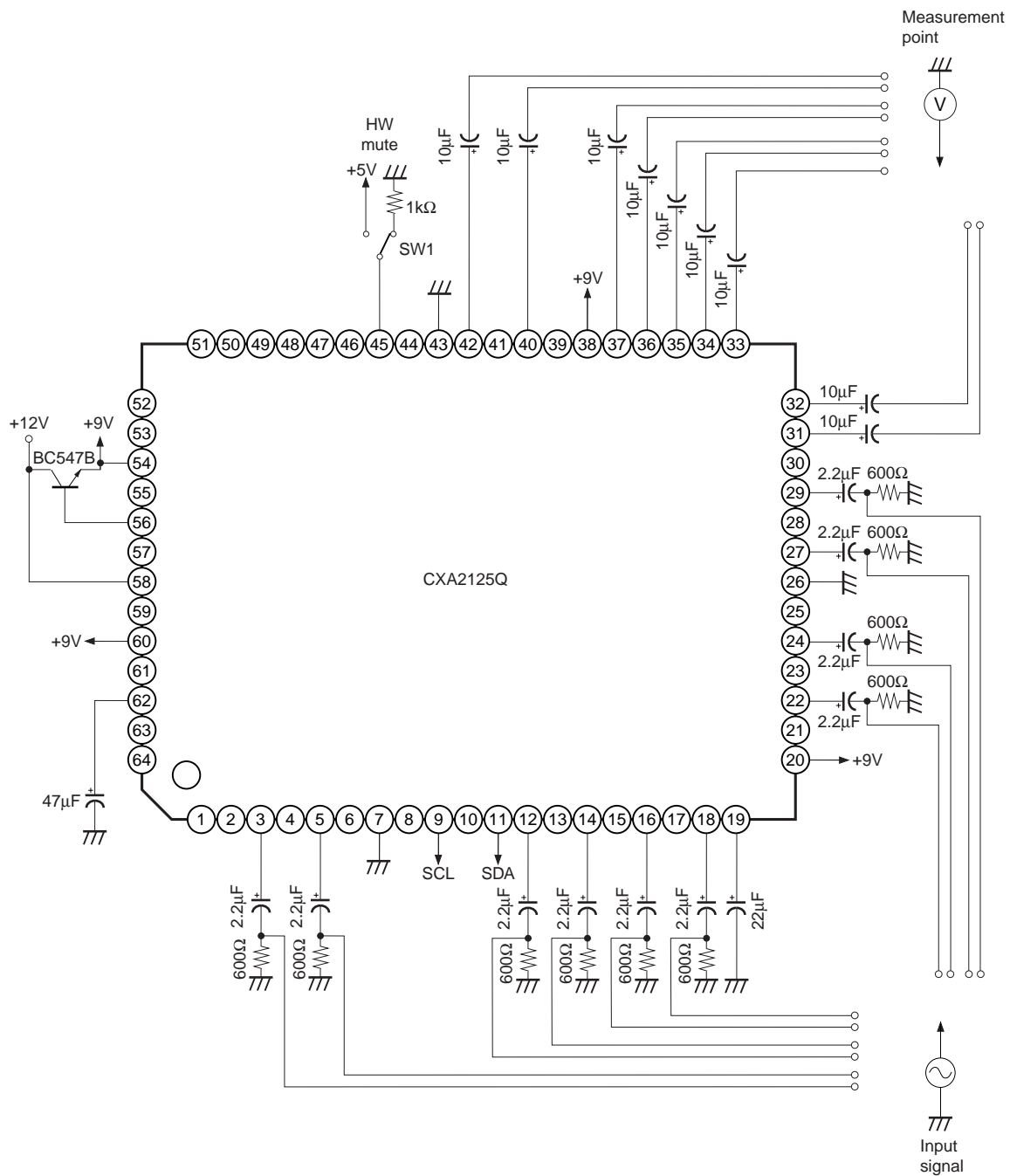

**Fig. 6. Audio system (gain, dynamic range, signal to noise, crosstalk, distortion, volume control)**

Signal applied to Pins, 3, 5, 12, 14, 16, 18, 22, 24, 27, 29

Output signal measured from Pins 31, 32, 33, 34, 35, 36, 37, 40, 42

- Notes)**
1. All +9V supplies de-coupled close to supply pins, 20, 38, 60 with 10nF ceramic capacitor.
  2. When muting audio using hardware mute, SW1 is closed.

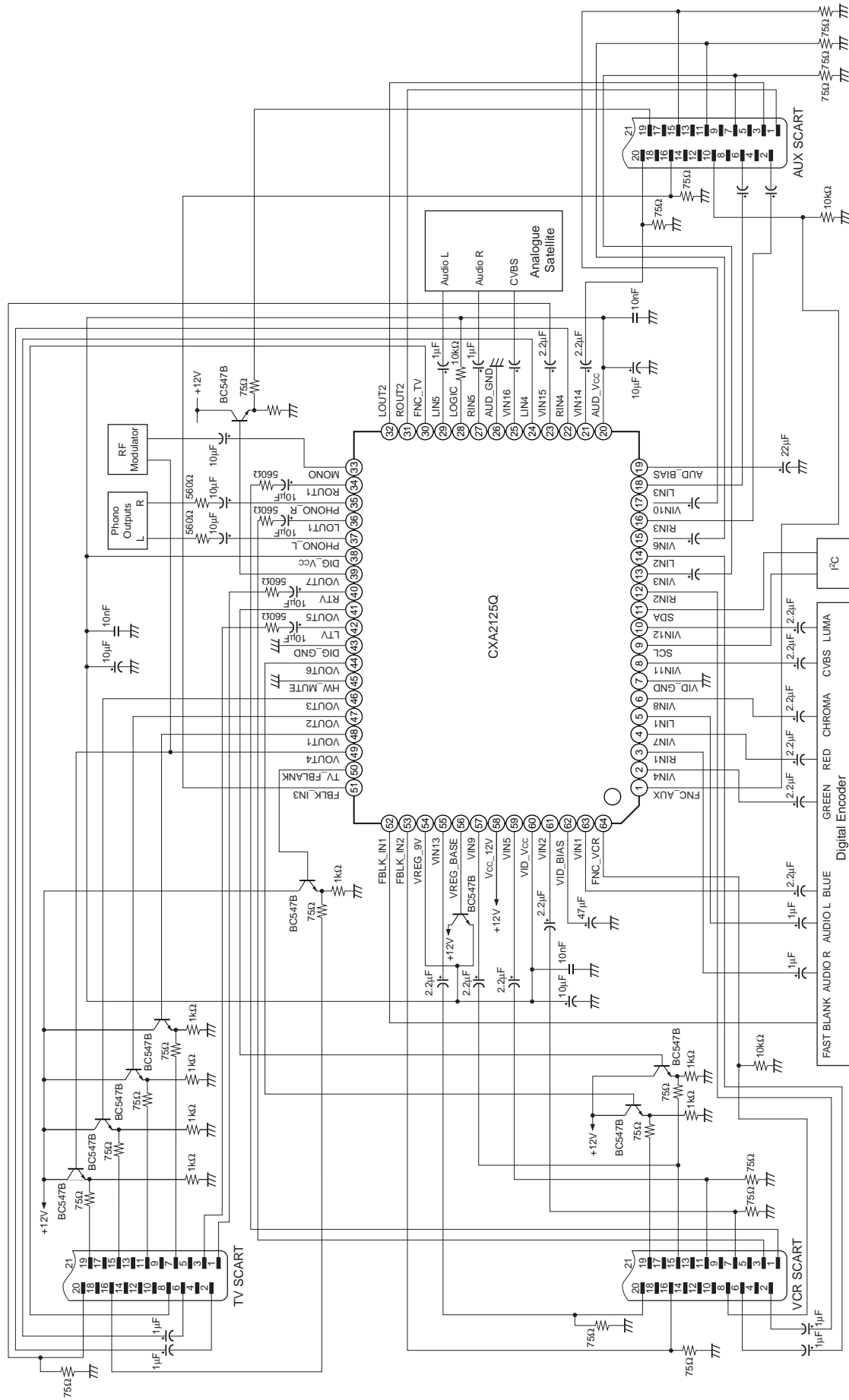

**Fig. 7. Audio system (bandwidth)**

Signal applied to Pins, 3, 5, 12, 14, 16, 18, 22, 24, 27, 29  
 Output signal measured from Pins 31, 32, 33, 34, 35, 36, 37, 40, 42

- Notes)** 1. All +9V supplies de-coupled close to supply pins, 20, 38, 60 with 10nF ceramic capacitor.  
 2. When muting audio using hardware mute, SW1 is closed.

Application Circuit



Application circuits shown are typical examples illustrating the operation of the devices. Sony cannot assume responsibility for any problems arising out of the use of these circuits or for any infringement of third party patent and other right due to same.

## Description of Operation

### 1. Explanation of Video Section

The video section comprises of 16 high impedance inputs switched through to 7 video outputs. A +6dB internal amplifier is connected to each output. The amplifier is required to compensate for the 6dB attenuation which occurs at the external emitter follower stage used for driving video loads. All video outputs have an integrated 100Ω series protection resistor. The typical external configuration is shown in Fig. 1-1.

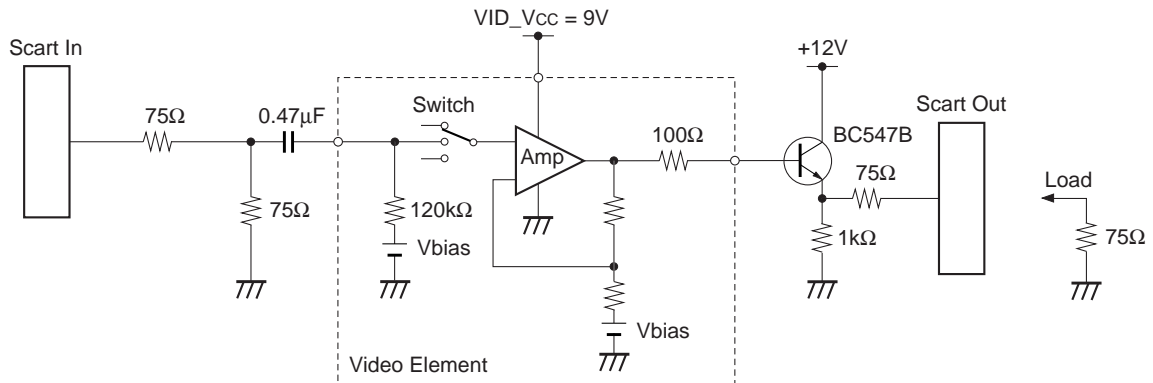

Fig. 1-1. Video Circuit Element: 6dB gain amplifier with external emitter follower

### Switching the Video Outputs Off

Each video output can be individually turned off using the I<sup>2</sup>C. When turned off, the output dc voltage is approximately 0V and hence the current consumption of the external emitter followers is reduced.

## 2. Explanation of Audio System

### Inputs and Outputs

The audio system consists of 5 stereo inputs, 3 stereo outputs and separate mono and phono outputs. The stereo outputs can be connected to any one of the 5 stereo inputs. All audio inputs have a  $-6\text{dB}$  attenuator except RIN1 and LIN1. Thus, the net gain of the audio system is  $0\text{dB}$ , as the internal switch is followed by an audio amplifier having  $+6\text{dB}$  of gain. The stereo input RIN1/LIN1 does not have an input attenuator and therefore the net gain from input to output is  $+6\text{dB}$ . The output impedance of each audio amplifier is near zero, and can be capacitively coupled directly to the external scart circuit. The output circuitry is typically a  $10\mu\text{F}$  capacitor, and an optional  $560\Omega$  series compliance resistor. Depending on the length and type of cable used in the scart cable connector, the load seen at the scart terminal will consist of a parallel capacitor, ( $100\text{pF}$  to  $400\text{pF}$ ) and mandatory  $10\text{k}\Omega$  resistor connected to ground. The customer may chose to place an alternative audio filter at the AV switch output.

### TV Audio Output

The TV audio section is composed of an audio switch followed by two variable gain stages, corresponding to the coarse and fine electronic volume control. The coarse volume control gives a  $0$  to  $-56\text{dB}$  range in  $8\text{dB}$  steps. Similarly the fine control gives a  $0$  to  $-7\text{dB}$  range in  $1\text{dB}$  steps. The volume control section is followed by a switchable  $0/+6\text{dB}$  amplifier which allows compensation for low level signals from a DAC. Finally, a mono switch allows the mixed R + L signal to be switched to the R and L output channels. (Fig. 2-1)

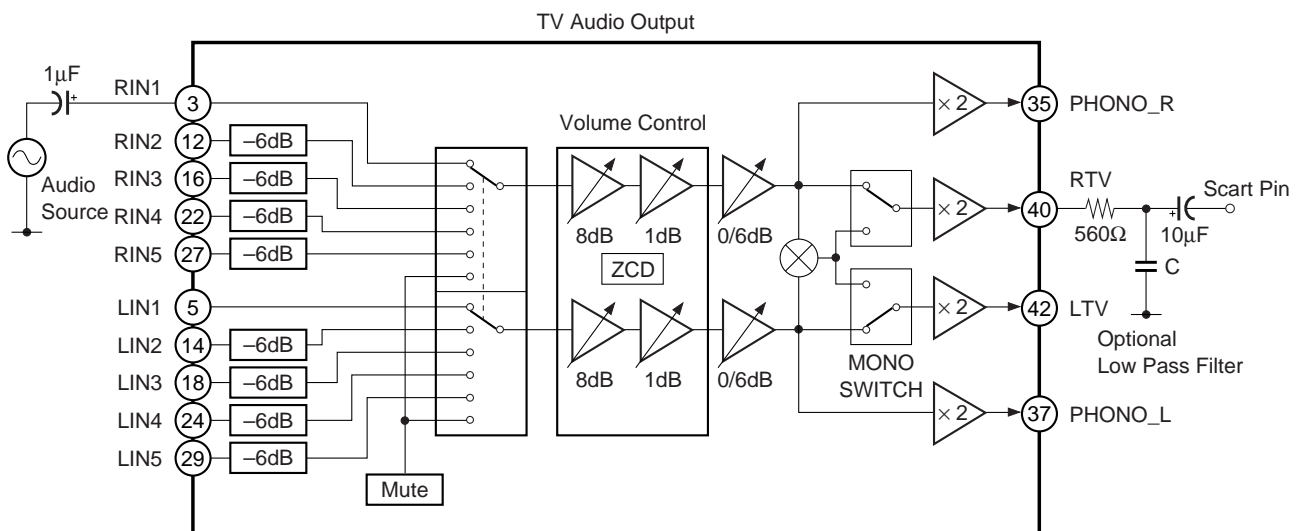

Fig. 2-1. TV Audio Output

### TV Mute

The I<sup>2</sup>C mute function acts only on the TV, phono and mono audio circuit. Audio mute can be implemented after a audio zero cross detection to reduce click noise, or immediately depending on the I<sup>2</sup>C setting of ZCD. It can be seen from the I<sup>2</sup>C write format that the same mute bit occurs in DATA 1 and DATA 7. This allows the software to action an immediate mute, make any suitable changes to the audio source or electronic volume control and after a minimum period of  $6 \times 90\mu\text{s}$  ( $540\mu\text{s}$ ) un-mute the output buffer. Such a period provides ample time to allow any transient ac voltages to settle during an audio source change.

**Zero Cross Detector (ZCD)**

The zero cross detector reduces the effect of "click noise" when implementing a volume change or an audio mute. The change volume or mute instruction sent by I<sup>2</sup>C will only be implemented when a minimal (ie zero cross) signal amplitude is detected.

The zero cross detection circuit can be turned off by setting the "ZCD" bit low in the I<sup>2</sup>C write mode.

**Hardware Mute**

A hardware mute pin is provided which will mute all audio outputs when the pin voltage exceeds 2.5V. This muting is instantaneous.

**VCR and AUX Output**

The outputs ROUT1, 2 and LOU1, 2 have a fixed gain of 0dB from the input. If any attenuation is required then it is possible to insert a series resistance on the input. (Fig. 2-2)

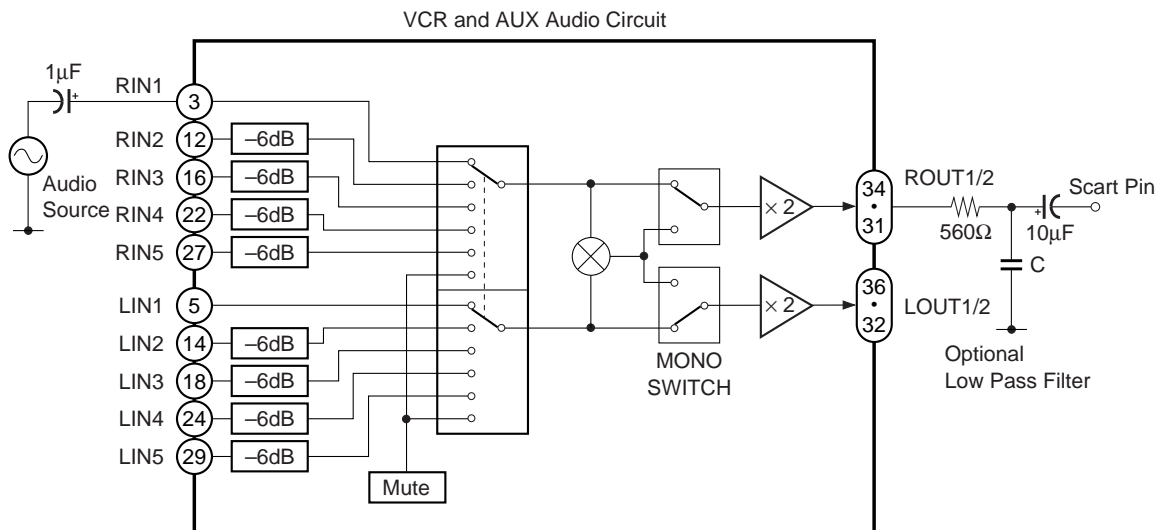

**Fig. 2-2. VCR and AUX Audio Output**

**Phono Outputs**

There is a stereo phono output which carries the same signal as the TV output. This is typically used for connection to a hi-fi. The user may connect an external attenuator which is a.c. coupled to the outputs.

**I<sup>2</sup>C Data Interface Table**

**IC Control Data Format**

S	Slave address	A	DATA1	A	DATA2	A	DATA3	A	DATA4	A	DATA <sub>n</sub>	A	P
---	---------------	---	-------	---	-------	---	-------	---	-------	---	-------------------	---	---

S: Start condition      A: Acknowledge      P: Stop condition

**Address = 90H**

**I<sup>2</sup>C Data Structure (write mode)**

	b7	b6	b5	b4	b3	b2	b1	b0
Address	1	0	0	1	0	0	0	0 = Write
Data1	EVC			EVF			TV Aud Mute	Z.C.D
Data2	Not used	Not used	Vid_Switch 1 TV			Aud_Switch 1 TV		
Data3	Vout5 Mute	Not used	Vid_Switch 2 VCR			Aud_Switch 2 VCR		
Data4	Not used	Not used	Vid_Switch 3 AUX			Aud_Switch 3 AUX		
Data5	Not used	Not used	FBLK			FNC		LOGIC
Data6	Not used	Vout7 on/off	Vout6 on/off	Vout5 on/off	Vout4 on/off	Vout3 on/off	Vout2 on/off	Vout1 on/off
Data7	TV Aud Mute	TV Aud Gain	mono AUX	mono VCR	mono TV	Not used	Not used	Not used

**Key**

- EVC:            Electronic Volume Course (8dB steps)
- EVF:            Electronic Volume Fine (1dB steps)
- TV Aud Mute: TV Audio mute. Controls the TV audio output buffer. (Same bit appears in data 1 & 7)
- Z.C.D:          Zero cross detector active. When ZCD = 1 volume and mute change at zero cross.
- Vid\_Switch 1: Selects the input video sources for Vout1, Vout2, Vout3, Vout4
- Vid\_Switch 2: Selects the input video sources for Vout5, Vout6
- Vid\_Switch 3: Selects the input video sources for Vout7
- Aud\_Switch 1: Selects one of 5 stereo inputs for RTV, LTV, PHONO\_L, PHONO\_R, MONO
- Aud\_Switch 2: Selects one of 5 stereo inputs for Rout1, Lout1
- Aud\_Switch 3: Selects one of 5 stereo inputs for Rout2, Lout2
- FNC:            Video function switch control
- FBLK:          Video Fast Blanking control
- LOGIC:        Logic outputs (open collector). 0 = high impedance. 1 = current sink mode.



**I<sup>2</sup>C Data Format (read mode)**

S	Slave address	A	DATA8	NA	P
---	---------------	---	-------	----	---

NA: No Acknowledge

**I<sup>2</sup>C Data Structure (read mode)**

	b7	b6	b5	b4	b3	b2	b1	b0
Address	1	0	0	1	0	0	0	1 = Read
Data	x	x	ZC Status	P.O.D.	FNC_AUX		FNC_VCR	

**Key**

- FNC\_VCR: At Pin 64, AV switch monitors the voltage of pin 8 from VCR scart, and records status.
- FNC\_AUX: At Pin 1, AV switch monitors the voltage of pin 8 from AUX scart, and records status.
- ZC Status: ZC Status = 1 indicates that zero cross condition has been achieved after the ZCD is turned on.
- P.O.D.: Power On Detect. P.O.D. = 1 when DIG\_Vcc voltage rises above a threshold level of approximately 5V.

### 3. Video Input I<sup>2</sup>C Control

#### Switch 1 (TV Output) Data 2 Bits 3, 4, 5

Switch setting	Vout1 (B)	Vout2 (Green)	Vout3 (R/C)	Vout4 (CVBS/Y)	Comment
0 x x 0 0 0 x x x	VIN1	VIN4	VIN7	VIN11	Digital encoder
1 x x 0 0 1 x x x	Bias	Bias	VIN8	VIN12	Digital encoder
2 x x 0 1 0 x x x	VIN2	VIN5	VIN9	VIN13	VCR
3 x x 0 1 1 x x x	VIN3	VIN6	VIN10	VIN14	AUX
4 x x 1 0 0 x x x	Bias	Bias	VIN7	VIN4	Digital encoder
5 x x 1 0 1 x x x	Bias	Bias	Bias	VIN15	TV
6 x x 1 1 0 x x x	Bias	Bias	Bias	VIN16	Analogue satellite
7 x x 1 1 1 x x x	Bias	Bias	Bias	Bias	Video mute

**Note)** After power on all TV outputs are off and muted.

#### Switch 2 (VCR Output) Data 3 Bits 3, 4, 5

Switch setting	Vout5 (Chroma (C))	Vout6 (CVBS/Y)	Comment
0 x x 0 0 0 x x x	VIN7	VIN11	Digital encoder
1 x x 0 0 1 x x x	VIN8	VIN12	Digital encoder
2 x x 0 1 0 x x x	VIN9	VIN13	VCR
3 x x 0 1 1 x x x	VIN10	VIN14	AUX
4 x x 1 0 0 x x x	VIN7	VIN4	Digital encoder
5 x x 1 0 1 x x x	Bias	VIN15	TV
6 x x 1 1 0 x x x	Bias	VIN16	Analogue satellite
7 x x 1 1 1 x x x	Bias	Bias	Video mute

**Note)** After power on VCR outputs are off and muted.

#### VCR Chroma Mute Data 3 Bit 7

0 x x x x x x x = Vout5 active. Connected to input specified in above table.

1 x x x x x x x = Vout5 muted (the output dc bias still remains).

**Switch 3 (AUX Output)** Data 4 Bits 3, 4, 5

Switch setting	Vout7 (CVBS)	Comment
0 x x 0 0 0 x x x	VIN11	Digital encoder
1 x x 0 0 1 x x x	Bias	Video mute
2 x x 0 1 0 x x x	VIN13	VCR
3 x x 0 1 1 x x x	VIN14	AUX
4 x x 1 0 0 x x x	VIN4	Digital encoder
5 x x 1 0 1 x x x	VIN15	TV
6 x x 1 1 0 x x x	VIN16	Analogue satellite
7 x x 1 1 1 x x x	Bias	Video mute

**Note)** After power up the AUX video outputs are off and muted.

**Standby Mode Control** Data 6 Bits 0, 1, 2, 3, 4, 5, 6

Each video output can be individually turned off using data byte 6.

0 = Video output off

1 = Video output on

**Note)** When switched off, the video outputs are high impedance to prevent d.c. driving of the external emitter follower stage.

The reduction of overall current consumption will depend on how many video outputs are turned off.

After power on all video outputs are in the off state.

**4. Fast Blanking Operation (Pin 16 on SCART), FBLK**

The fast blanking signal instructs the TV to select either the external CVBS information or the external RGB information. This is used to superimpose an on screen display (OSD) presentation (normally RGB) upon a CVBS background. Fast blanking information has the same nominal phase as the RGB and CVBS signal, and is defined as follows,

Fast blanking output at scart,

- 1. CVBS mode                      Scart pin voltage = 0 to 0.4V
- 2. RGB mode                      Scart pin voltage = 1 to 3.0V

Threshold voltage is approximately 0.75V at the scart input.

**Fast Blanking I<sup>2</sup>C Control**

In the CXA2125Q, there are three fast blanking inputs, one associated with the Digital Encoder input (FBLANK\_IN1), one with the VCR RGB/CVBS input (FBLANK\_IN2), and another associated with the AUX RGB/CVBS input (FBLANK\_IN3). These can be selected by I<sup>2</sup>C. In addition to the two blanking inputs, the fast blank pin output can be set to a constant 0V or 5V by means of the I<sup>2</sup>C control. Hence there are four possible states. These are controlled according to the following table.

**FBLK Control**    Data 5    Bits 3, 4, 5

I <sup>2</sup> C Setting	Fast Blank Output
0    x x 0 0 0 x x x	0V
1    x x 0 0 1 x x x	+5V
2    x x 0 1 0 x x x	Same level as Fast Blank in 1 (0/+5V)
3    x x 0 1 1 x x x	Same level as Fast Blank in 2 (0/+5V)
4    x x 1 0 0 x x x	Same level as Fast Blank in 3 (0/+5V)
5    x x 1 0 1 x x x	+5V
6    x x 1 1 0 x x x	+5V
7    x x 1 1 1 x x x	+5V

**Note)** After power on the output is 0V.

**Fast Blank output circuit**

The output requires an external buffer stage to drive the required 75Ω scart termination. The levels at the IC output are 0V and +5V.

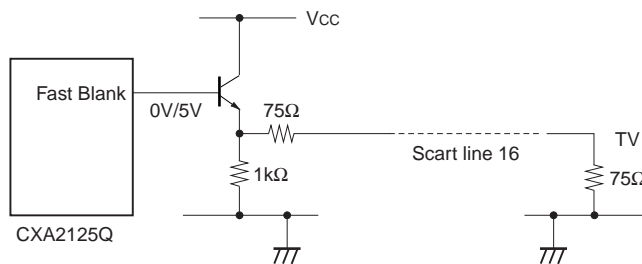

**Fig. 4-1. Fast Blanking Interface to TV SCART**

**5. Function Switch, FNC.**

The function switch facility is designed to read the status of the SCART function pin 8 from the VCR input. The read register holds the status of the input function lines.

The function output is controlled by I<sup>2</sup>C and is used to change the voltage on the function line to the TV. The output can be connected directly to the scart pin. (Fig. 5-1)

**Read Mode**

Reads the status of the inputs FNC\_VCR and FNC\_AUX.

Input Pin Voltage	Level (SCART Defn.)	Read Data8	
		b1/b3	b0/b2
0 to +2V (default)	(Internal TV)	0	0
+4.5 to +7V	(16:9 External)	0	1
+9.5 to +12V	(4:3 External)	1	1

**Write Mode**

Controls the voltage at the TV function line (pin 8)

I <sup>2</sup> C Control (Data 5)	Mode/(Typical pin Voltage)
0 x x x x 0 0 x	Internal TV/(1V)
1 x x x x 0 1 x	External scart input 16:9 mode/(6V)
2 x x x x 1 0 x	External scart input 4:3 mode/(11V)
3 x x x x 1 1 x	External scart input 4:3 mode/(11V)

**Note)** After power on output is internal TV mode ie. 0V at the pin.

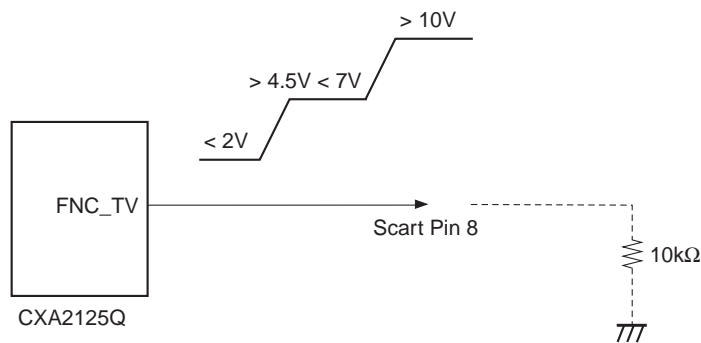

**Fig. 5-1. TV Function Switch Output**

## 6. Logic Output

A single logical output pin is provided. This is controlled via the I<sup>2</sup>C and is an open collector output.

### Specification

I<sup>2</sup>C bit 0 = open collector/high output impedance

I<sup>2</sup>C bit 1 = V<sub>sat</sub> (to 0.2V)

V<sub>max</sub> at logic pin = 12V

I<sub>max</sub> during current sink = 1mA

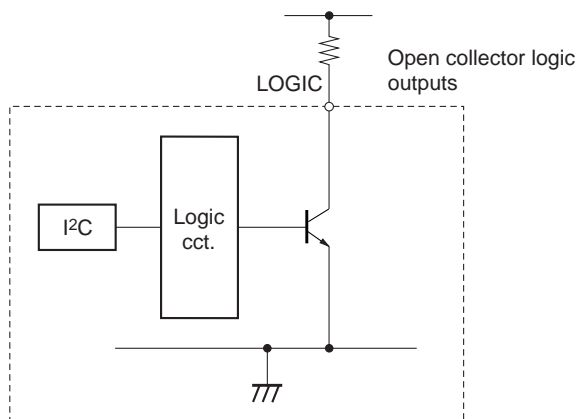

**Fig. 6-1. Logic Output Interface**

7. I<sup>2</sup>C Audio Signal Control

Outputs TV, VCR, AUX Data 2, 3, 4 Bits 0, 1, 2

Switch Setting	RTV, ROUT1, ROUT2	LTV, LOUT1, LOUT2
0 x x x x x 0 0 0	Rin1	Lin1
1 x x x x x 0 0 1	Rin2	Lin2
2 x x x x x 0 1 0	Rin3	Lin3
3 x x x x x 0 1 1	Rin4	Lin4
4 x x x x x 1 0 0	Rin5	Lin5
5 x x x x x 1 0 1	Audio mute	Audio mute
6 x x x x x 1 1 0	Audio mute	Audio mute
7 x x x x x 1 1 1	Audio mute	Audio mute

Note) After power on the audio outputs are muted.

Volume Control Fine Data 1 Bits 2, 3, 4

Setting	Volume Fine Control Gain
0 x x x 0 0 0 x x	0dB
1 x x x 0 0 1 x x	-1dB
2 x x x 0 1 0 x x	-1dB
3 x x x 0 1 1 x x	-3dB
4 x x x 1 0 0 x x	-4dB
5 x x x 1 0 1 x x	-5dB
6 x x x 1 1 0 x x	-6dB
7 x x x 1 1 1 x x	-7dB

Volume Control Coarse Data 1 Bits 5, 6, 7

Setting	Gain
0 0 0 0 x x x x x	0dB
1 0 0 1 x x x x x	-8dB
2 0 1 0 x x x x x	-16dB
3 0 1 1 x x x x x	-24dB
4 1 0 0 x x x x x	-32dB
5 1 0 1 x x x x x	-40dB
6 1 1 0 x x x x x	-48dB
7 1 1 1 x x x x x	-56dB

**TV output amplifier** Data 7 Bit 6

x 0 x x x x x x = 0dB

x 1 x x x x x x = +6dB

**Note)** After power on the gain is set to 0dB.

**TV Mono Switch** Data 7 Bit 3

x x x x 0 x x x = Normal stereo output

x x x x 1 x x x = Mono signal switched onto R + L line.

**VCR Mono Switch** Data 7 Bit 4

x x x 0 x x x x = Normal stereo output

x x x 1 x x x x = Mono signal switched onto R + L line.

**AUX Mono Switch** Data 7 Bit 5

x x x 0 x x x x = Normal stereo output

x x x 1 x x x x = Mono signal switched onto R + L line.

**Mute and Zero Cross Operation**

For TV, Phono and mono outputs.

There are two mute control bits in the bus map to allow the TV outputs to be muted before the channel change instruction occurs. The normal structure for a click free audio channel change is as follows:

Data 1 Mute the TV audio output with the ZCD switched on.

Data 2 Change the TV audio source.

Data 7 Un-mute the TV audio output again with the ZCD switched on.

<b>TV Aud Mute</b> Data 1 Bit 1 Data 7 Bit 7	<b>ZCD</b> Data 1 Bit 0	RTV, LTV, Phono_R, Phono_L, Mono outputs
0	0	Un-mute immediately
0	1	Un-mute on next zero cross
1	0	Mute immediately
1	1	Mute on next zero cross

**Note)** After power on TV Mute and ZCD are set to 0.



**Notes on operation**

- 1) Supply de-coupling capacitors, 10nF and 4.7 $\mu$ F in parallel should be inserted as close to the supply pins, 20, 38, 60 as possible.
- 2) To minimize crosstalk, attention should be given to the routing of audio and video to the IC inputs. PCB track lengths should be kept as short as possible and preferably, audio placed on a separate layer to the video.
- 3) Attention should be given to the electrolytic capacitors on the input and output signal pins. As the pin's voltage is between 3.7V and 4.7V dc the positive terminal on the capacitor should be orientated towards the pin.
- 4) The audio outputs may be muted at any time after power up by connecting the HW\_MUTE pin (45) to a voltage > 2.5V and < 9V.
- 5) When driving video loads with impedance = 75 $\Omega$  an emitter follower or video line driver is required to be connected at the video outputs as shown in the application schematic.  
Stray capacitance on pins Vout1-8 must be kept to a minimum by placing loads as close to the pins as possible.
- 6) The supply voltage on pin 58 "Vcc\_12V" should not exceed +12V. If the supply has poor regulation then a series diode or zener diode may be used to limit the voltage at this pin.

Typical audio output distortion

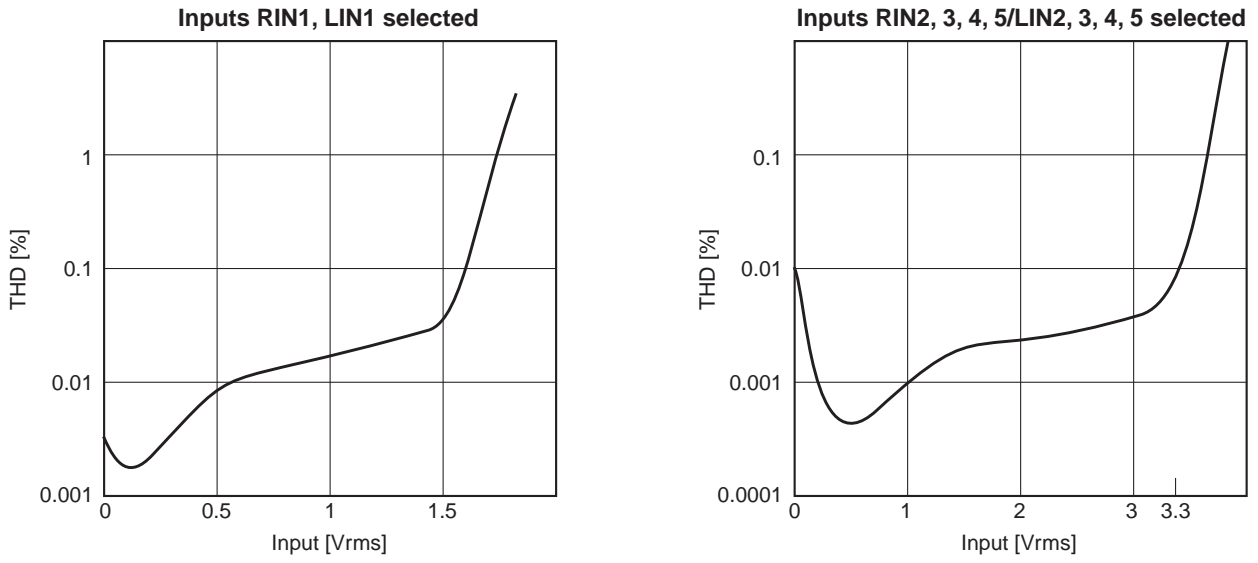

Audio frequency characteristics

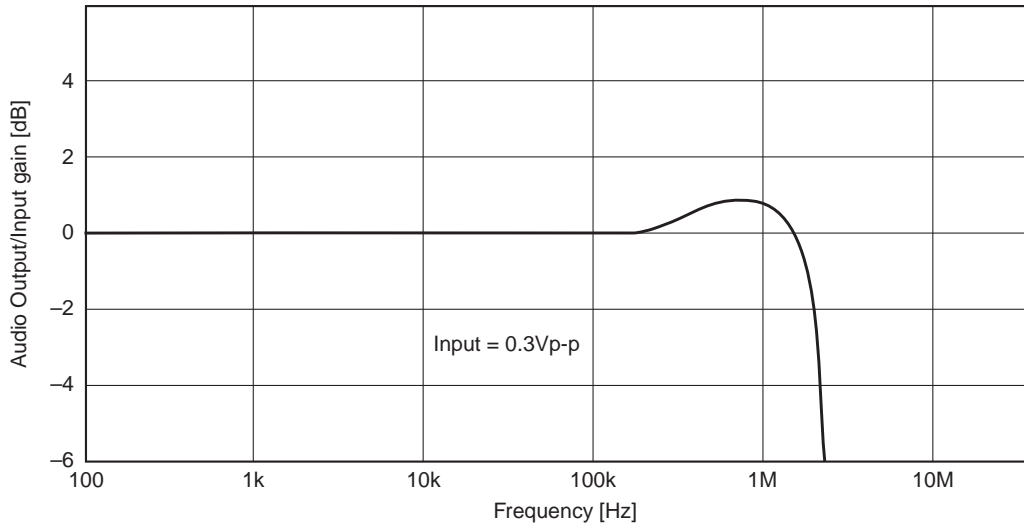

Video frequency characteristics

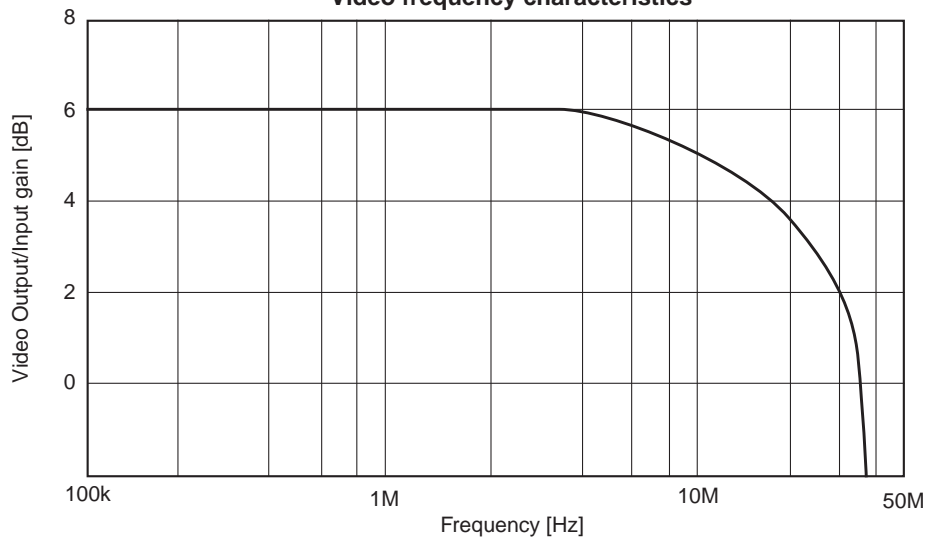

Package Outline Unit: mm

64PIN QFP(PLASTIC)

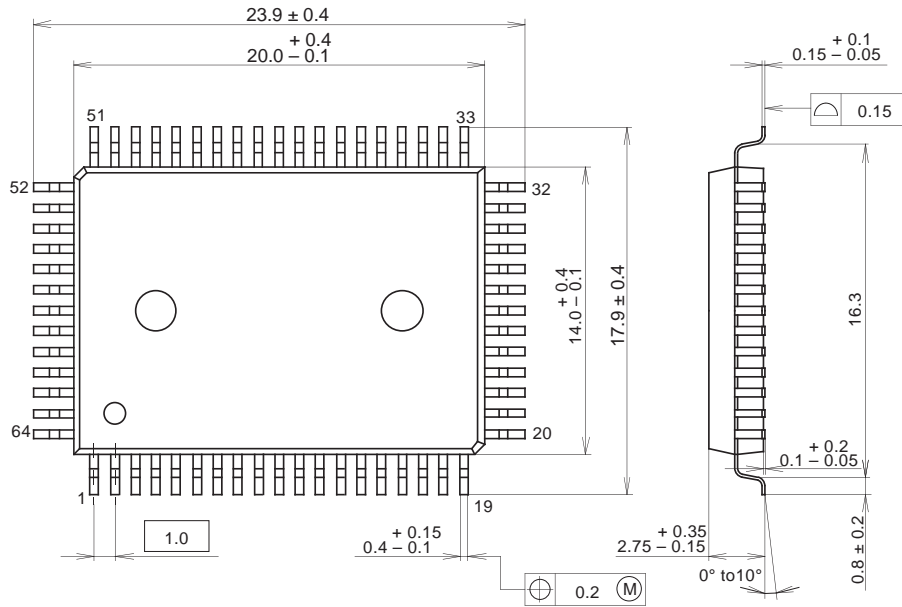

PACKAGE STRUCTURE

SONY CODE	QFP-64P-L01
EIAJ CODE	QFP064-P-1420
JEDEC CODE	_____

PACKAGE MATERIAL	EPOXY RESIN
LEAD TREATMENT	SOLDER/PALLADIUM PLATING
LEAD MATERIAL	42/COPPER ALLOY
PACKAGE MASS	1.5g