

MTD2003

FEATURES

- Constant-current chopping function
(Frequency fixed, separate-oscillation)
- 4-phase input
(with inhibit for simultaneously turn ON)
- Current levels can be selected in
2 bit digital signal
- A noise cancel function is provided
(No externally attached filter needed)
- Protection for penetration current
- Built-in flywheel diodes

RATINGS

● Absolute Maximum Ratings (Ta=25°C)

Item	Symbol	Ratings	Unit
Output Voltage	$V_{CEO(SUS)}$	30	V
Output Current	I_O	1.2	A
Logic Supply Voltage	V_{CC}	0~6	V
Logic Input Voltage	V_{IN}	0~ V_{CC}	V
Total Power Dissipation	P_T	5	W
Junction Temperature	T_j	150	°C
Storage Temperature	T_{stg}	-40~150	°C

● Electrical Characteristics (Ta=25°C)

Item	Symbol	Test Conditions	min.	typ.	max.	Unit
Output Saturation Voltage(Upper side)	$V_{CE(sat)H}$	$I_o=1.0A$		1.2	1.4	V
Output Saturation Voltage(Lower side)	$V_{CE(sat)L}$	$I_o=1.0A$		0.7	1.0	V
Output Leakage Current(Upper side)	I_{rH}	$V_{mm}=30V, V_{out}=0V$			10	μA
Output Leakage Current(Lower side)	I_{rL}	$V_{out}=30V, V_{rs}=0V$			10	μA
Logic Supply Current(Standby)	$I_{CC(OFF)}$	$V_{CC}=5V, IN="H,H"$ or $"L,L"$		15	25	mA
Logic Supply Current(All Circuit ON)	$I_{CC(ON)}$	$V_{CC}=5V$		50	65	mA
Input High Voltage	V_{INH}	$V_{CC} = 5V$	2.7		V_{CC}	V
Input Low Voltage	V_{INL}	$V_{CC} = 5V$	GND		0.6	V
Logic High Input Current	I_{INH}	$V_{CC} = 5V, V_{IN}=5V$			10	μA
Logic Low Input Current	I_{INL}	$V_{CC} = 5V, V_{IN}=0V$		-3	-20	μA
I_o, I_i "H" Input Voltage	$V(I_o, I_i)H$	$V_{CC}=5V$	2.7		V_{CC}	V
I_o, I_i "L" Input Voltage	$V(I_o, I_i)L$	$V_{CC}=5V$	GND		0.6	V
I_o, I_i "H" Input Current	$I(I_o, I_i)H$	$V_{CC}=5V, V(I_o, I_i)=5V$			10	μA
I_o, I_i "L" Input Current	$I(I_o, I_i)L$	$V_{CC}=5V, V(I_o, I_i)=0V$		-75	-100	μA
Current Sensor Threshold(100%)	V_{S1}	$V_{CC}=V_r=5V, V(I_o)=0V, V(I_i)=0V$	0.475	0.5	0.525	V
Current Sensor Threshold(70%)	V_{S2}	$V_{CC}=V_r=5V, V(I_o)=5V, V(I_i)=0V$	0.322	0.35	0.378	V
Current Sensor Threshold(33%)	V_{S3}	$V_{CC}=V_r=5V, V(I_o)=0V, V(I_i)=5V$	0.153	0.17	0.187	V
Reference Input Current	I_{ref}	$V_{CC}=5V, V_r=5V$		500	650	μA
Input Current(Current Sensor)	I_{sense}	$V_{CC}=5V, V_s=0V$		-1	-10	μA
Pulse Blanking Time	t_b	$V_{CC}=5V, C_t=3300pF$		1.55		μs

OUTLINE DIMENSIONS

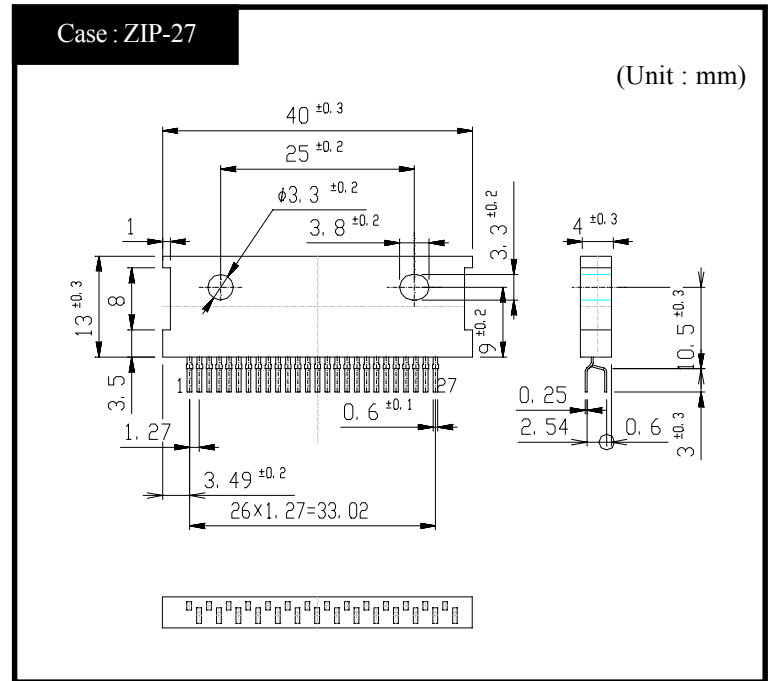

● Equivalent Circuit · Basic Application Circuit

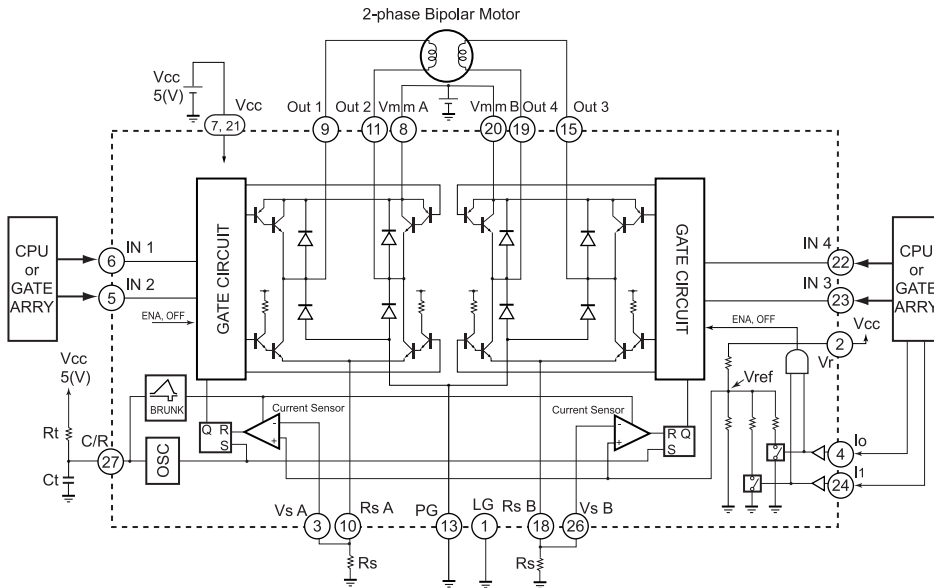

● Pin Assignment

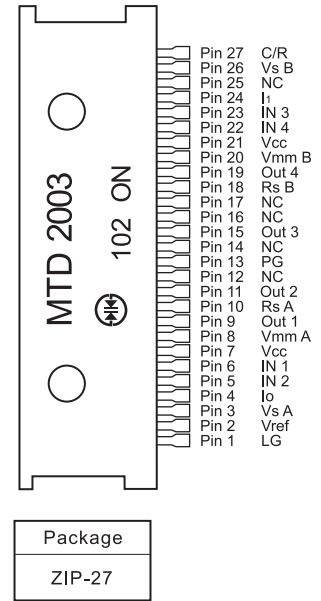

● True Table

IN 1 or 4	IN 2 or 3	Out 1 or 4	Out 2 or 3
L	L	OFF	OFF
L	H	L	H
H	L	H	L
H	H	OFF	OFF

● Recommended Parts Value

Symbol	Recommended Value	Unit
Rs	0.68	Ω
Rt	18	kΩ
Ct	3300	pF
Vr	Vcc	V

● True Table for Current Chopping Level

Io	I1	Current Level (%)	Vref(V) (Vr=5V)
L	L	100	0.5 ± 5%
H	L	70	0.35 ± 8%
L	H	33	0.17 ± 10%
H	H	0	

● Setting of Output Current and Chopping Frequency

Fig.1 shows constant current chopping wave form.

○ Output Current setting

$$I_o(100\%) = \frac{V_r}{10 \cdot R_s} - 0.015$$

○ Chopping Frequency Setting

$$f = \frac{1}{0.72 \cdot C_t \cdot R_t}$$

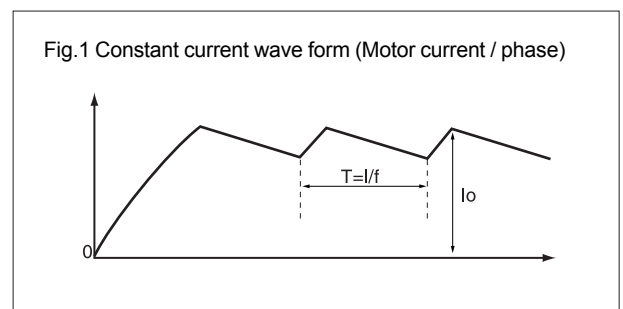

● Recommended Operating Conditions (Ta=25°C)

Item	Symbol	min.	typ.	max.	Unit
Motor Supply Voltage	Vmm			27	V
Output Current	Io			1	A
Logic Supply Voltage	Vcc	4.75		5.25	V
Chopping Frequency	fchop		20		kHz
Operating Temperature	Top	-25		120	°C