



Z89302/04/06

DIGITAL TELEVISION CONTROLLER

FEATURES

Device	ROM (KB)	RAM* (Bytes)	Speed MHz
Z89302	24	640	12
Z89304	16	640	12
Z89306	12	640	12

Note: * General-Purpose

- 40-Pin DIP Packages
- 4.75- to 5.25-Volt Operating Range

- 0°C to +70°C Temperature Range
- Fully Customized Character Set
- Character-Control and Closed-Caption Modes
- Keypad User Control
- TV Tuner Serial Interface
- Direct Video Signals

GENERAL DESCRIPTION

The Z89302/04/06 Digital Television Controllers are designed to provide complete audio and video control of television receivers, video recorders, and advanced on-screen display facilities. The Television Controllers feature a Z89C00 RISC processor core that controls the on-board peripheral functions and registers using the standard processor instruction set.

Character attributes can be controlled through two modes: the on-screen display Character-Control Mode and the Closed-Caption Mode. The Character-Control Mode provides access to the full set of attribute controls, allowing the modification of attributes on a character-by-character basis. The insertion of control characters permits direction of other character attributes.

The fully customized 512 character set, formatted in two 256 character banks, can be displayed with a host of display attributes that include underlining, italics, blinking, eight foreground/background colors, character position offset delay, and background transparency.

Serial interfacing with the television tuner is provided through the tuner serial port. Other serial devices, such as digital channel tuning adjustments, may be accessed through the industry-standard I²C port.

User control can be monitored through the keypad scanning port, or the 16-bit remote control capture register. Receiver functions such as color and volume can be directly controlled by eight 8-bit pulse width modulated ports.

The Z89302/04/06 has two internal 12 MHz VCOs that are referenced to a 32 kHz internal oscillator to provide the system clock. In Sleep Mode, the controller uses the 32 kHz clock for the system clock to reduce power consumption. The processor can be suspended by placing it into STOP Mode when main power is not available for low-power consumption.

GENERAL DESCRIPTION (Continued)

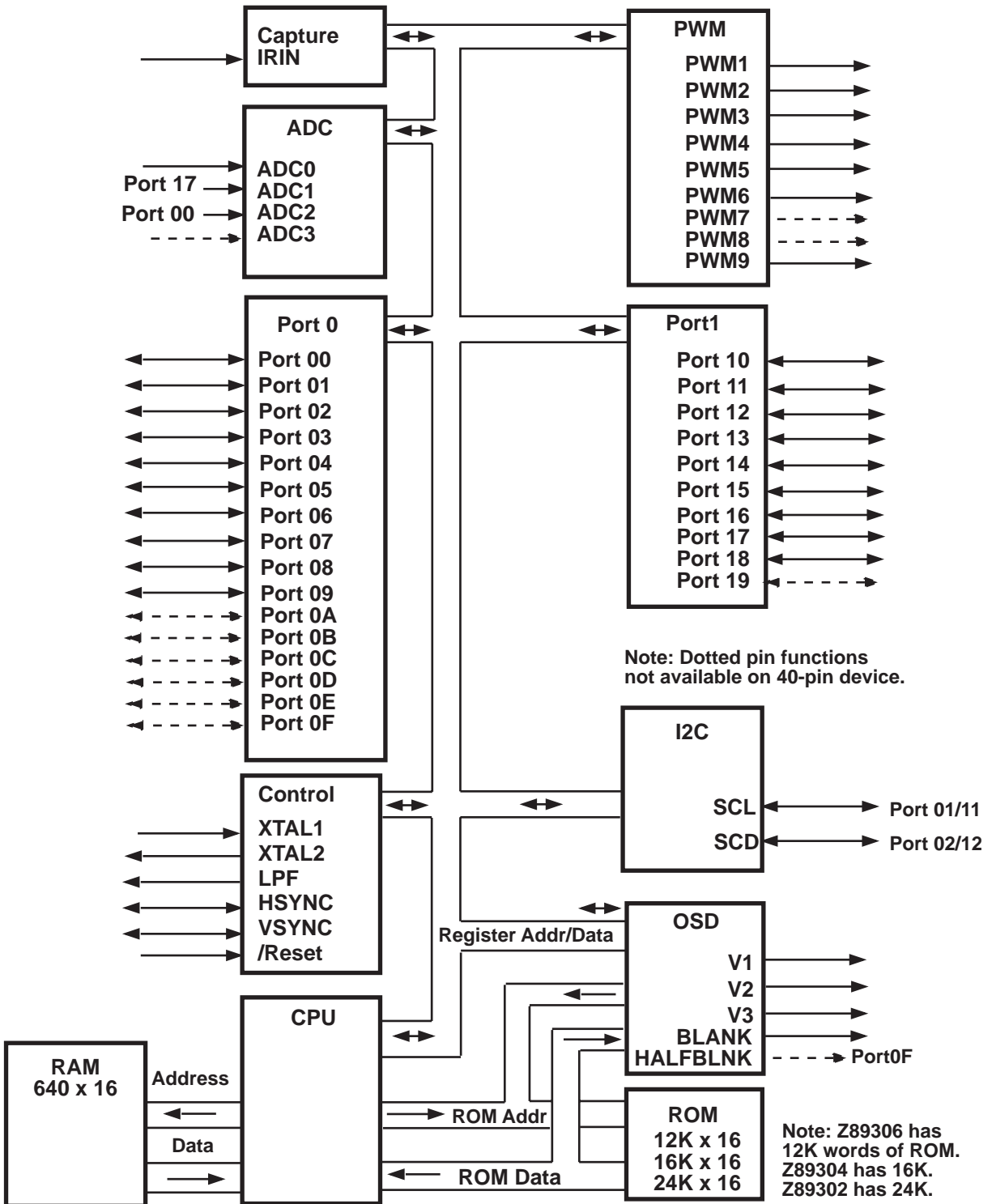

Figure 1. Z8930X Functional Block Diagram

PIN DESCRIPTION

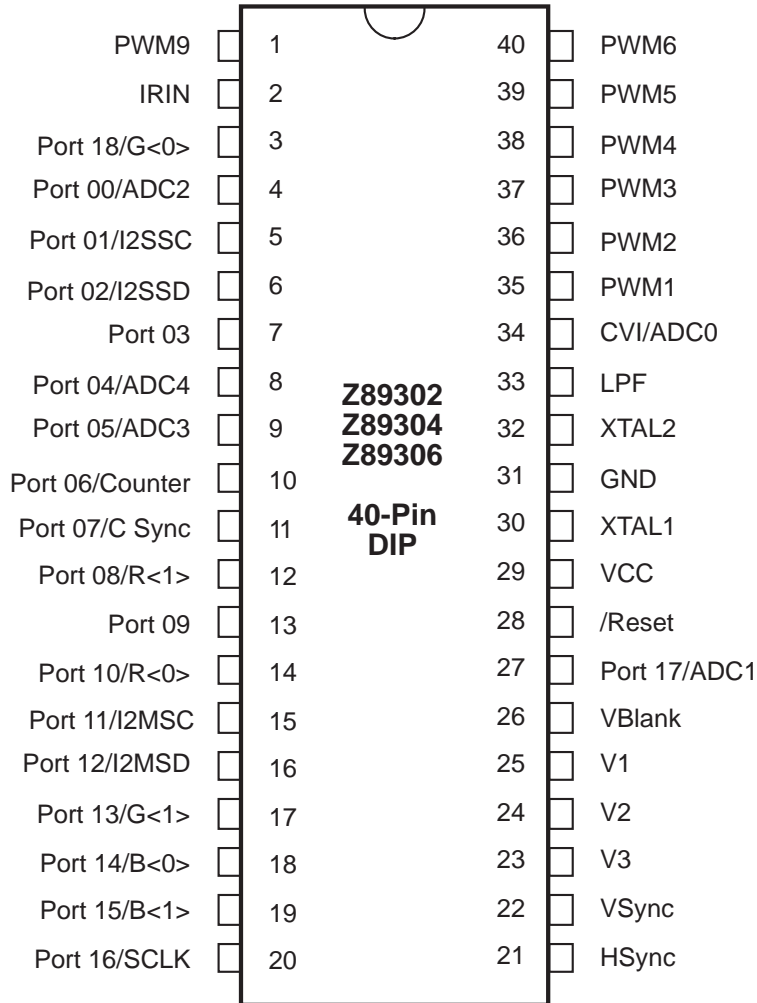

Figure 2. 40-Pin DIP Configuration

PIN DESCRIPTIONS

Z89302/03/06/07

Pin Name	Function	40-Pin, Z89302/04/06	Direction	Reset Configuration
V _{cc}	+5V	29,-		PWR-
GND	0V	31,-		PWR-
IRIN	Infrared Remote Capture Input	2	I	I
ADC[5:0]	4-Bit Analog to Digital Converter Input	-,9,8,4,27,34	nAI	I
PWM9	14-Bit Pulse Width Modulator Output	1	OD/O ^a	O
PWM[8:1]	8-Bit Pulse Width Modulator Output	-,-,40,39,38	OD/O ^a	O
Port0[F:0]	Bit Programmable Input/Output Ports	-,-,-,-,-,13,12,11,10,9,8,7,6,5,4	B	I
Port1[9:0]	Bit Programmable Input/Output Ports	-,3,27,20,19,18,17,16,15,14	B	I
SCL ^b	I ² C Clock I/O	5 or 15	BOD	
SCD ^c	I ² C Data I/O	6 or 16	BOD	
XTAL1	Crystal Oscillator Input	30	AI	I
XTAL2	Crystam Oscillator Output	32	AO	O
LPF	Loop Filter	33	AB	O
HSYNC	H_Sync	21	B	I
VSYNC	V_Sync	22	B	I
/RESET	Device Reset	28	I	I
V[3:1]	OSD Video Output (Typically Drive B, G, and R Outputs)	23,24,25	O	O
Blank	OSD Blank Output	26	O	O
Half Blank ^d	OSD Half Blank Output	-	O	I
RGB Digital Outputs ^e	R[1:0],G[1:0], and B[1:0] Outputs of the RGB Matrix	19,18,17,14,12,3	O	
SCLK ^f	Internal Processor SCLK		O	

Notes:

- Port19 is not available on the 40-pin DIP Version, Revision D is Push-Pull.
- SCL I/O pin is shared with Port01 or Port11
- SCD I/O pin is shared with Port02 or Port12
- Half Blank output is a function shared with Port0F. Half Blank output is not available on the 40-pin DIP version.
- Digital RGB outputs and the internal SCLK are shared with Port1[5:0].
- Internal processor SCLK is shared with Port16.

ABSOLUTE MAXIMUM RATINGS

Symbol	Parameter	Min	Max	Units	Conditions
V_{CC}	Power Supply Voltage	0	7	V	
V_{ID}	Input Voltage	-0.3	$V_{CC} + 0.3$	V	Digital Inputs
V_{IA}	Input Voltage	-0.3	$V_{CC} + 0.3$	V	Analog Inputs (A/D0-A/D4)
V_O	Output Voltage	-0.3	$V_{CC} + 0.3$	V	All Push-Pull Digital Output
V_O	Output Voltage	-0.3	$V_{CC} + 0.3$	V	Open-Drain/Push-Pull PWM Outputs (PWM1-PWM8)
I_{OH}	Output Current High		-10	mA	One Pin
I_{OH}	Output Current High		-100	mA	All Pins
I_{OL}	Output Current Low		20	mA	One Pin
I_{OL}	Output Current Low		200	mA	All Pins
T_A	Operating Temperature	0	70	°C	
T_A	Storage Temperature	-65	150	°C	

Note: Revision D and later have push-pull PWM outputs.

DC CHARACTERISTICS

$T_A = 0^\circ\text{C}$ to $+70^\circ\text{C}$; $V_{CC} = 4.5\text{ V}$ to $+5.5\text{ V}$; $F_{OSC} = 32.768\text{ kHz}$

Symbol	Parameter	Min	Max	Typical	Units	Conditions
V_{IL}	Input Voltage Low	0	$0.2 V_{CC}$	0.4	V	
V_{IH}	Input Voltage High	$0.6 V_{CC}$	V_{CC}	3.6	V	
V_{PU}	Max. Pull-Up Voltage		5		V	All Pins
V_{OL}	Output Voltage Low		0.4	0.16	V	@ $I_{OL} = 1\text{ mA}$
V_{OH}	Output Voltage High	$V_{CC} - 0.9$		4.75	V	@ $I_{OL} = 0.75\text{ mA}$
V_{XL}	Input Voltage XTAL1 Low		$0.3 V_{CC}$	1.0	V	External Clock
V_{XH}	Input Voltage XTAL1 High	$V_{CC} - 2.0$		3.5	V	Generator Driven
V_{HY}	Schmitt Hysteresis	3.0	0.75	0.5	V	On XTAL1 Input Pin
I_{IR}	Reset Input Current		150	90	μA	$V_{RL} = 0\text{V}$
I_{IL}	Input Leakage	-3.0	3.0	0.01	μA	@ 0 V and V_{CC}
I_{CC}	Supply Current		100	60	mA	
I_{CC1E}	Supply Current of the OTP		700	300	μA	Sleep Mode @ 32 kHz
I_{CC1}	Supply Current		300	100	μA	Sleep Mode @ 32 kHz
I_{CC2}	Supply Current		10	5	μA	Sleep Mode
I_{ADC}	Input Current		0.5		mA	C Revision
I_{ADC}	Input Current		10		μA	D Revision

V1,V2,V3 ANALOG OUTPUT

Condition	4.75 V	5.25 V	
11	3.6 – 4.4	4.0 – 5.0	V_{II}
10	79% of $V_{II} \pm 5\%$		
01	50% of $V_{II} \pm 5\%$		
00	0.0 – 0.8V		

Notes:

Maximum Variance Between V1, V2, V3 is 100 mV
Settling Time 70% of DC Level, 10pF Load <50n Sec

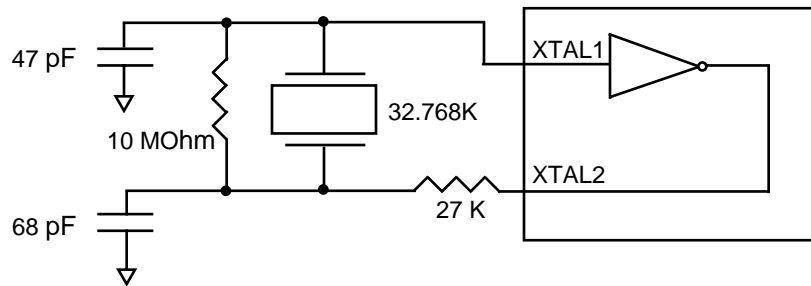

32K Oscillator Recommended Circuit

Figure 3. 32K Oscillator Recommended Circuit

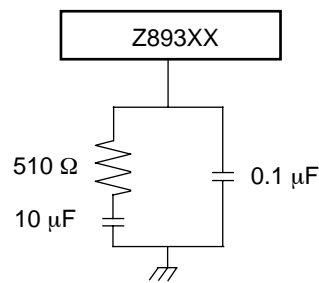

Figure 4. Low Pass Filter

AC CHARACTERISTICS

$T_A = 0^\circ\text{C}$ to $+70^\circ\text{C}$; $V_{CC} = 4.5\text{ V}$ to 5.5 V ; $F_{OSC} = 32.768\text{ kHz}$

Symbol	Parameter	Min	Max	Typical	Units
T_{PC}	Input Clock Period	16	100	32	μs
T_{RC}, T_{FC}	Clock Input Rise and Fall			12	μs
T_{DPOR}	Power-On Reset Delay	0.8		1.2	s

AC CHARACTERISTICS

$T_A = 0^\circ\text{C}$ to $+70^\circ\text{C}$; $V_{CC} = 4.5\text{ V}$ to 5.5 V ; $F_{OSC} = 32.768\text{ kHz}$

Symbol	Parameter	Min.	Max.	Typical	Units
T_{wRES}	Power-On Reset Min. Width		5TPC		μs
T_{dH_s}	H_Sync Incoming Signal Width	5.5	12.5	11	μs
T_{dV_s}	V_Sync Incoming Signal Width	0.15	1.5	1.0	ms
T_{dE_s}	Time Delay Between Leading Edge of V_Sync and H_Sync on Even Field	-12	+12	0	μs
T_{dO_s}	Time Delay Between Leading Edge of H_Sync in Odd Field	20	44	32	μs
T_{wHV_s}	H_Sync/V_Sync Edge Width		2.0	0.5	μs

Note: All timing of the I²C bus interface is defined by related specifications of the I²C bus interface.

ANALOG INPUT

ADC0

Step	Min.	Max
1	1.45	1.55
15	Step 1 + 0.468	Step 1 + 0.532

ADC1

Step	Min.	Max
1	0.2	0.4
15	Step_1 + 4.95	Step_1 + 5.15

Note: $V_{CC} = 5\text{V}$

Development Projects:

Customer is cautioned that while reasonable efforts will be employed to meet performance objectives and milestone dates, development is subject to unanticipated problems

and delays. No production release is authorized or committed until the Customer and Zilog have agreed upon a Customer Procurement Specification for this project.

Pre-Characterization Product:

The product represented by this CPS is newly introduced and Zilog has not completed the full characterization of the product. The CPS states what Zilog knows about this product at this time, but additional features or non-conformance with some aspects of the CPS may be found,

either by Zilog or its customers in the course of further application and characterization work. In addition, Zilog cautions that delivery may be uncertain at times, due to start-up yield issues.

© 1996 by Zilog, Inc. All rights reserved. No part of this document may be copied or reproduced in any form or by any means without the prior written consent of Zilog, Inc. The information in this document is subject to change without notice. Devices sold by Zilog, Inc. are covered by warranty and patent indemnification provisions appearing in Zilog, Inc. Terms and Conditions of Sale only. Zilog, Inc. makes no warranty, express, statutory, implied or by description, regarding the information set forth herein or regarding the freedom of the described devices from intellectual property infringement. Zilog, Inc. makes no warranty of merchantability or fitness for any purpose. Zilog, Inc. shall not be responsible for any errors that may appear in this document. Zilog, Inc. makes no commitment to update or keep current the information contained in this document.

Zilog's products are not authorized for use as critical components in life support devices or systems unless a specific written agreement pertaining to such intended use is executed between the customer and Zilog prior to use. Life support devices or systems are those which are intended for surgical implantation into the body, or which sustains life whose failure to perform, when properly used in accordance with instructions for use provided in the labeling, can be reasonably expected to result in significant injury to the user.

**Zilog, Inc., 210 East Hacienda Ave.
Campbell, CA 95008-6600
Telephone (408) 370-8000
FAX: (408) 370-8056
Internet: <http://www.zilog.com>**