



March 2005
Revised April 2005

FSUSB20

Low Voltage Ultra Low Power USB High Speed (480 Mbps) Dual DPDT Switch (Preliminary)

General Description

FSUSB20 is a low power high bandwidth analog switch specially designed for applications of the switching of high speed USB 2.0 signals in handset and consumer applications such as cell phone, digital camera, and notebook with hubs or controllers of limited USB I/O. The wide bandwidth (>720MHz) of this switch allows signals to pass with minimum edge and phase distortion. Superior channel-to-channel crosstalk results in minimal interference. It is compatible with high speed USB2.0 standard.

Features

- -30dB OFF Isolation at 250MHz
- -30dB non-adjacent channel crosstalk at 250MHz
- 4.5Ω typical On Resistance (R_{ON})
- -3dB bandwidth: >720MHz
- Low power consumption (1uA max)
- Control input: LVTTTL compatible
- Bidirectional operation
- USB high speed and full speed signaling capability

Applications

- Cell phone, PDA, digital camera, and notebook

Ordering Code:

Order Number	Package Number	Package Description
FSUSB20L10X (Preliminary)	MAC010A	Pb-Free 10-Lead MicroPak, 1.6 mm x 2.1mm
FSUSB20BQX	MLP014A	Pb-Free 14-Terminal Depopulated Quad Very-Thin Flat Pack No Leads (DQFN), JEDEC MO-241, 2.5 x 3.0mm

Pb-Free package per JEDEC J-STD-020B.

MicroPak™ is a trademark of Fairchild Semiconductor Corporation.

FSUSB20 Low Voltage Ultra Low Power USB High Speed (480 Mbps) Dual DPDT Switch (Preliminary)

FSUSB20

Analog Symbol

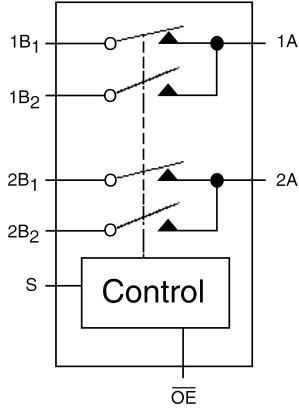

Connection Diagrams

Pad Assignments for MicroPak

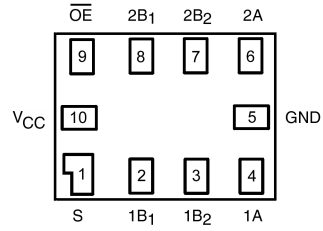

(Top View)

Pad Assignments for DQFN

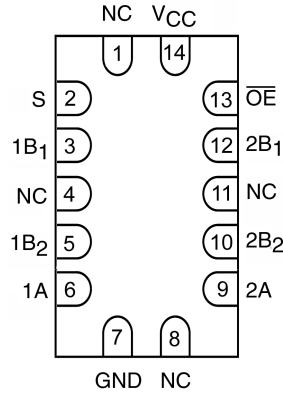

(Top Through View)

Pin Descriptions

Pin Name	Description
OE	Bus Switch Enable
S	Select Input
A	Bus A
B ₁ -B ₂	Bus B

Truth Table

S	OE	Function
X	H	Disconnect
L	L	A = B ₁
H	L	A = B ₂

Absolute Maximum Ratings (Note 1)		Recommended Operating Conditions (Note 3)	
Supply Voltage (V_{CC})	-0.5V to +4.6V	Power Supply Operating (V_{CC})	3.0V to 3.6V
DC Switch Voltage (V_S)	-0.5V to $V_{CC} + 0.05V$	Input Voltage (V_{IN})	0V to V_{CC}
DC Input Voltage (V_{IN}) (Note 2)	-0.5V to +4.6V	Output Voltage (V_{OUT})	0V to V_{CC}
DC Input Diode Current (I_{IK}) $V_{IN} < 0V$	-50 mA	Input Rise and Fall Time (t_r, t_f)	
DC Output (I_{OUT}) Sink Current	50 mA	Switch Control Input	0 ns/V to 5 ns/V
DC V_{CC}/GND Current (I_{CC}/I_{GND})	± 100 mA	Switch I/O	0 ns/V to DC
Storage Temperature Range (T_{STG})	-65°C to +150 °C	Free Air Operating Temperature (T_A)	-40 °C to +85 °C
ESD			
Human Body Model			
All Pins	4kV		
I/O to GND	5kV		

Note 1: The Absolute Maximum Ratings are those values beyond which the safety of the device cannot be guaranteed. The device should not be operated at these limits. The parametric values defined in the Electrical Characteristics tables are not guaranteed at the absolute maximum rating. The Recommended Operating Conditions tables will define the conditions for actual device operation.

Note 2: The input and output negative voltage ratings may be exceeded if the input and output diode current ratings are observed.

Note 3: Unused control inputs must be held HIGH or LOW. They may not float.

DC Electrical Characteristics

Symbol	Parameter	V_{CC} (V)	$T_A = -40\text{ }^\circ\text{C to } +85\text{ }^\circ\text{C}$			Units	Conditions
			Min	Typ (Note 4)	Max		
V_{IK}	Clamp Diode Voltage	3.0			-1.2	V	$I_{IN} = -18\text{ mA}$
V_{IH}	HIGH Level Input Voltage	3.0 - 3.6	2.0			V	
V_{IL}	LOW Level Input Voltage	3.0 - 3.6			0.8	V	
I_I	Input Leakage Current	3.6			± 1.0	μA	$0 \leq V_{IN} \leq 3.6V$
I_{OFF}	OFF-STATE Leakage Current	3.6			± 1.0	μA	$0 \leq A, B \leq V_{CC}$
R_{ON}	Switch On Resistance (Note 5)	3.0		5.0	7.0	Ω	$V_{IN} = 0.8V$ $I_{ON} = 8\text{ mA}$
		3.0		4.5	6.5	Ω	$V_{IN} = 3.0V$ $I_{ON} = 8\text{ mA}$
ΔR_{ON}	Delta R_{ON}	3.0		0.3		Ω	$V_{IN} = 0.8V, V_{IN} = 0V - 1.5V, I_{ON} = 8\text{ mA}$
$R_{FLAT(ON)}$	On Resistance Flatness (Note 6)	3.0		1.0	1.3	Ω	$I_{OUT} = 8\text{ mA}$
I_{CC}	Quiescent Supply Current	3.6			1.0	μA	$V_{IN} = V_{CC}$ or GND, $I_{OUT} = 0$

Note 4: Typical values are at $V_{CC} = 3.0V$ and $T_A = +25^\circ\text{C}$

Note 5: Measured by the voltage drop between A and B pins at the indicated current through the switch. On Resistance is determined by the lower of the voltages on the two (A or B) pins.

Note 6: Flatness is defined as the difference between the maximum and minimum value On Resistance over the specified range of conditions.

AC Electrical Characteristics

Symbol	Parameter	V _{CC} (V)	T _A = -40°C to +85°C			Units	Conditions	Figure Number
			Min	Typ (Note 7)	Max			
t _{ON}	Turn ON Time S-to-Bus B	3.0 to 3.6		4.8	7.0	ns	V _B = 0.8V	Figures 5, 6
t _{OFF}	Turn OFF Time S-to-Bus B	3.0 to 3.6		2.2	4.0	ns	V _B = 0.8V	Figures 5, 6
t _{PD}	Propagation Delay	3.0 to 3.6		0.25		ns	C _L = 10 pF	Figure 10
O _{IRR}	Non-Adjacent OFF-Isolation	3.0 to 3.6		-28.0		dB	f = 250MHz, R _L = 50Ω	Figure 7
X _{TALK}	Non-Adjacent Channel Crosstalk	3.0 to 3.6		-30.0		dB	R _L = 50Ω, f = 250MHz	Figure 8
BW	-3dB Bandwidth	3.0 to 3.6		750		MHz	R _L = 50Ω	Figure 9

Note 7: Typical values are at V_{CC} = 3.3V and T_A = +25°C

USB Related AC Electrical Characteristics (Note 8)

Symbol	Parameter	V _{CC} (V)	T _A = -40°C to +85°C			Units	Conditions	Figure Number
			Min	Typ	Max			
t _{SK(O)}	Channel-to-Channel Skew	3.0 to 3.6		0.051		ns	C _L = 10 pF	Figures 10, 11
t _{SK(P)}	Skew of Opposite Transition of the Same Output	3.0 to 3.6		0.020		ns	C _L = 10 pF	Figures 10, 11
T _J	Total Jitter	3.0 to 3.6		0.210		ns	R _L = 50Ω, C _L = 10 pF t _R = t _F = 750ps at 480 Mbps	

Note 8: Typical values are at V_{CC} = 3.3V and T_A = +25°C

Capacitance (Note 9)

Symbol	Parameter	T _A = -40°C to +85°C		Units	Conditions
		Typ			
C _{IN}	Control Pin Input Capacitance	2.5		pF	V _{CC} = 0V
C _{ON}	A/B ON Capacitance	12.0		pF	V _{CC} = 3.3V, OE = 0V
C _{OFF}	Port B OFF Capacitance	4.0		pF	V _{CC} and OE = 3.3V

Note 9: Typical values are at V_{CC} = 3.3V and T_A = +25°C

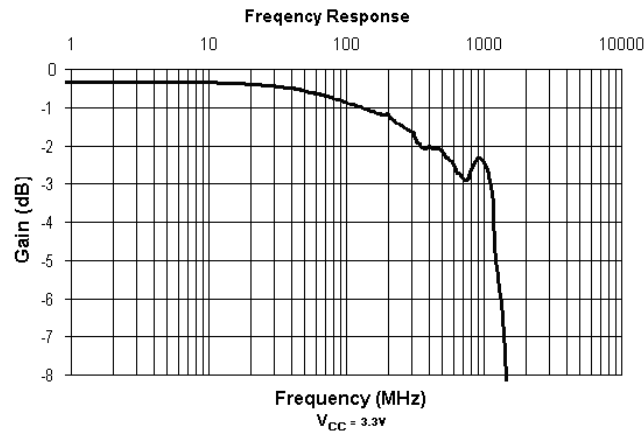

FIGURE 1. Gain vs. Frequency

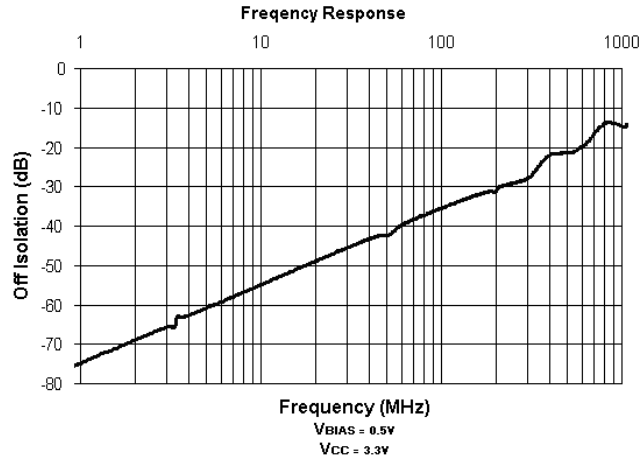

FIGURE 2. OFF Isolation

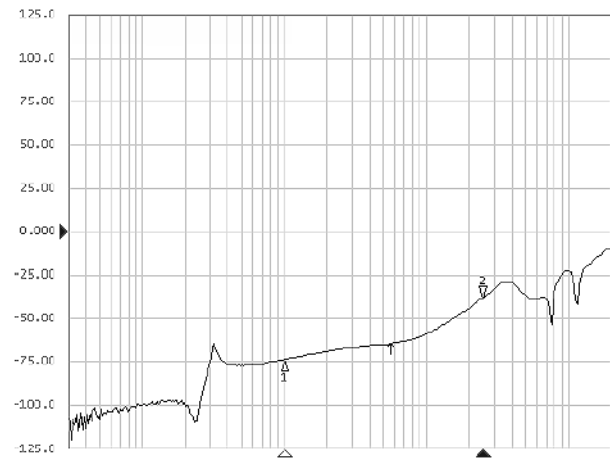

FIGURE 3. Crosstalk

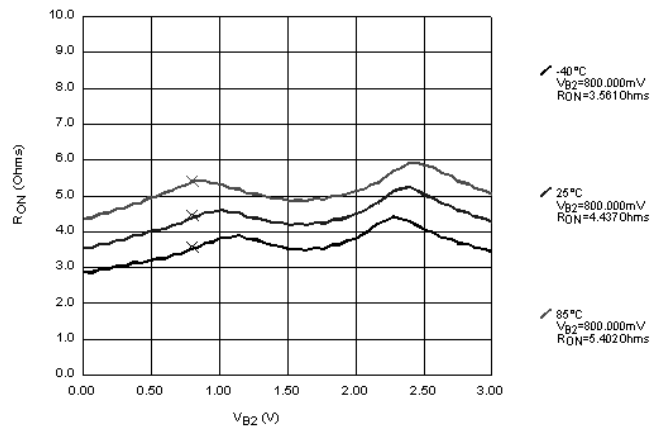
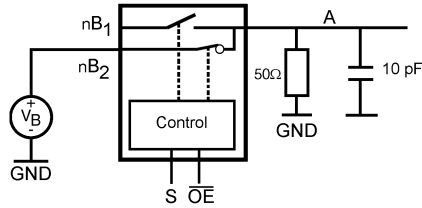

FIGURE 4. R_{ON}

AC Loading and Waveforms



Note: Input driven by 50Ω source terminated in 50Ω
 Note: C_L includes load and stray capacitance
 Note: Input PRR = 1.0 MHz, t_W = 500 ns

FIGURE 5. AC Test Circuit

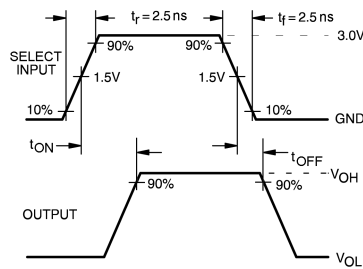

FIGURE 6. AC Waveforms

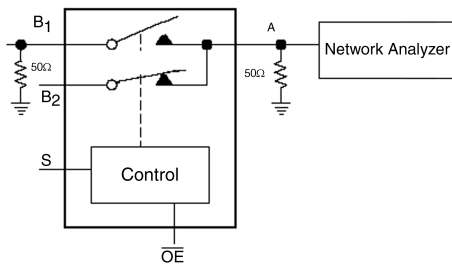

FIGURE 7. OFF Isolation Test

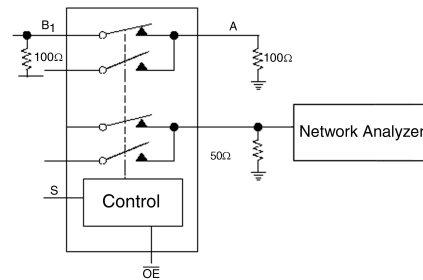

FIGURE 8. Crosstalk Test

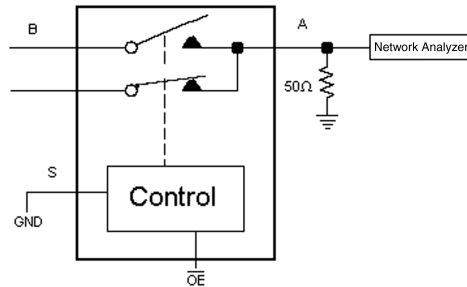

FIGURE 9. Bandwidth Test

AC Loading and Waveforms (Continued)

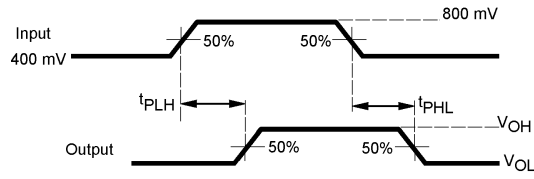
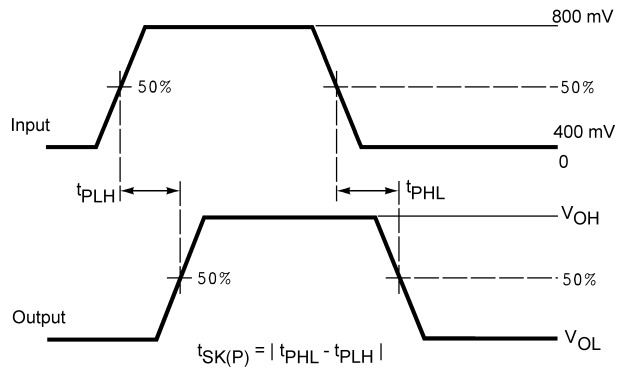
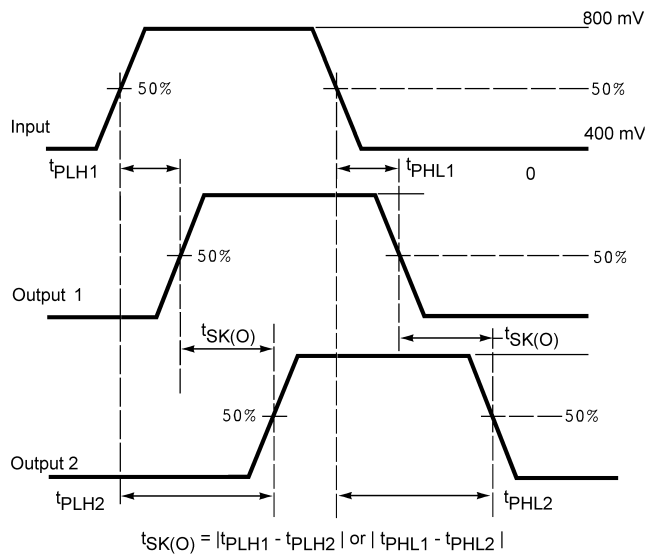

FIGURE 10. Propagation Delay



Pulse Skew $t_{SK(P)}$



Output Skew $t_{SK(O)}$

FIGURE 11. Skew Test

FSUSB20

Tape and Reel Specification

Tape Format For Micropak

Package Designator	Tape Section	Number Cavities	Cavity Status	Cover Tape Status
L10X	Leader (Start End)	125 (typ)	Empty	Sealed
	Carrier	5000	Filled	Sealed
	Trailer (Hub End)	75 (typ)	Empty	Sealed

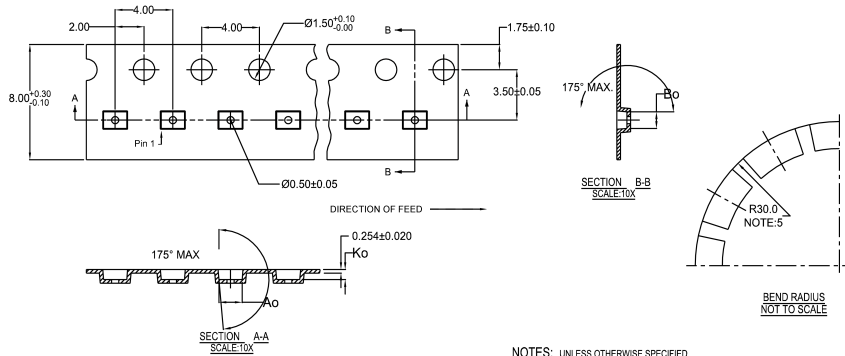

10	300056	2.30±0.05	1.78±0.05	0.68±0.05
8	300038	1.78±0.05	1.78±0.05	0.68±0.05
6	300033	1.60±0.05	1.15±0.05	0.70±0.05

NOTES: UNLESS OTHERWISE SPECIFIED

1. ACCUMULATED 50 SPROCKETS, SPROCKET HOLE PITCH IS 200.00 ±0.30MM
2. NO INDICATED CORNER RADIUS IS 0.127MM
3. CAMBER NOT TO EXCEED 1MM IN 100MM
4. SMALLEST ALLOWABLE BENDING RADIUS
5. POCKET POSITION RELATIVE TO SPROCKET HOLE MEASURED AS TRUE POSITION OF POCKET, NOT POCKET HOLE

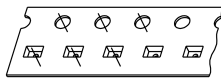

SCALE: 6X

REEL DIMENSIONS inches (millimeters)

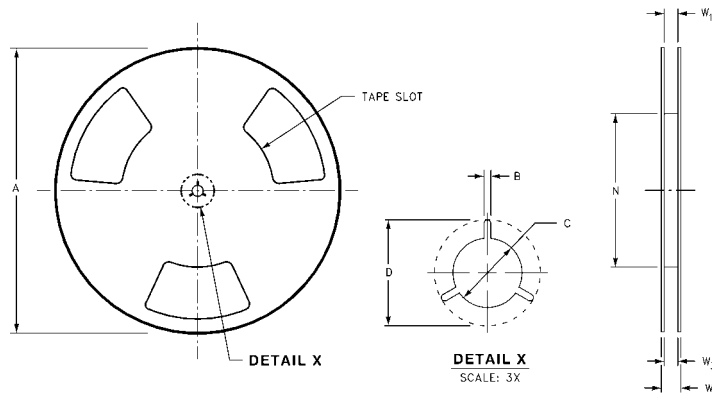

Tape Size	A	B	C	D	N	W1	W2	W3
8 mm	7.0 (177.8)	0.059 (1.50)	0.512 (13.00)	0.795 (20.20)	2.165 (55.00)	0.331 + 0.059/-0.000 (8.40 + 1.50/-0.00)	0.567 (14.40)	W1 + 0.078/-0.039 (W1 + 2.00/-1.00)

Tape and Reel Specification (Continued)

Tape Format for DQFN

Package Designator	Tape Section	Number Cavities	Cavity Status	Cover Tape Status
BQX	Leader (Start End)	125 (typ)	Empty	Sealed
	Carrier	2500/3000	Filled	Sealed
	Trailer (Hub End)	75 (typ)	Empty	Sealed

TAPE DIMENSIONS inches (millimeters)

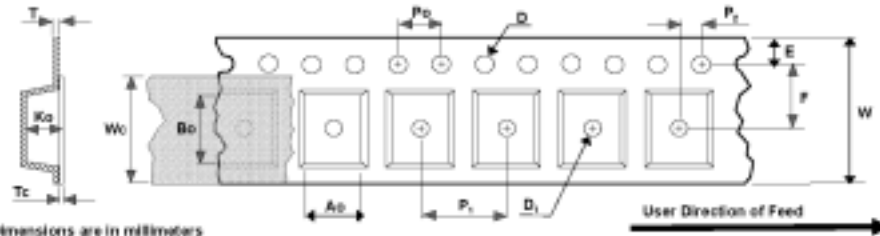

Dimensions are in millimeters

Package	A ₀ +/-0.10	B ₀ +/-0.10	D +/-0.05	D ₁ min	E +/-0.1	F +/-0.1	K ₀ +/-0.1	P ₁ TYP	P ₂ TYP	P ₃ +/-0.05	T TYP	T _c +/-0.005	W +/-0.3	W _c TYP
2x2	2.30	2.30	1.55	1.0	1.75	3.5	1.0	8	4	2.0	0.3	0.07	8	5.3
2.5x2.5	2.80	2.80	1.55	1.5	1.75	5.5	0.9	8	4	2.0	0.3	0.07	12	9.3
2.5x3.0	2.80	3.30	1.55	1.5	1.75	5.5	0.9	8	4	2.0	0.3	0.07	12	9.3
2.5x3.5	2.80	3.80	1.55	1.5	1.75	5.5	0.9	8	4	2.0	0.3	0.07	12	9.3
2.5x4.5	2.80	4.80	1.55	1.5	1.75	5.5	0.9	8	4	2.0	0.3	0.07	12	9.3
3.5x4.5	3.80	4.80	1.55	1.5	1.75	5.5	0.9	8	4	2.0	0.3	0.07	12	9.3
2.5x3.0	2.80	3.30	1.55	1.5	1.75	5.5	0.9	8	4	2.0	0.3	0.07	12	9.3
4x4	4.35	4.35	1.55	1.5	1.75	5.5	1.1	8	4	2.0	0.3	0.07	12	9.3
5x5	5.35	5.35	1.55	1.5	1.75	5.5	1.1	8	4	2.0	0.3	0.07	12	9.3
6x6	6.30	6.30	1.55	1.5	1.75	7.5	1.1	12	4	2.0	0.3	0.07	16	13.3

Notes: A₀, B₀, and K₀ dimensions are determined with respect to the EIA/Jedec RS-481 rotational and lateral movement requirements (see sketches A, B, and C).

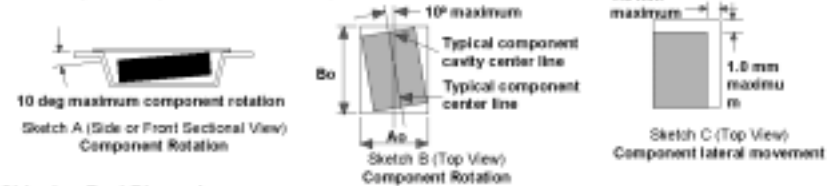

Shipping Reel Dimension

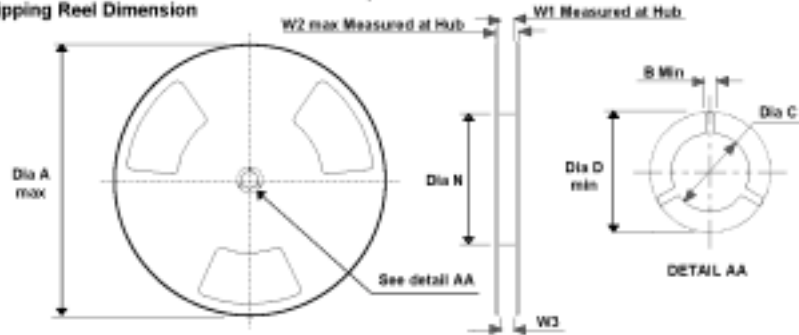

Dimensions are in millimeters

Tape Width	Dia A max	Dim B min	Dia C +5/-2	Dia D min	Dia N min	Dim W1 +2/-0	Dim W2 max	Dim W3 (L8L - USBL)
8	330	1.5	13	20.2	178	8.4	14.4	7.9-10.4
12	330	1.5	13	20.2	178	12.4	18.4	11.9-15.4
16	330	1.5	13	20.2	178	16.4	22.4	15.9-19.4

Physical Dimensions inches (millimeters) unless otherwise noted

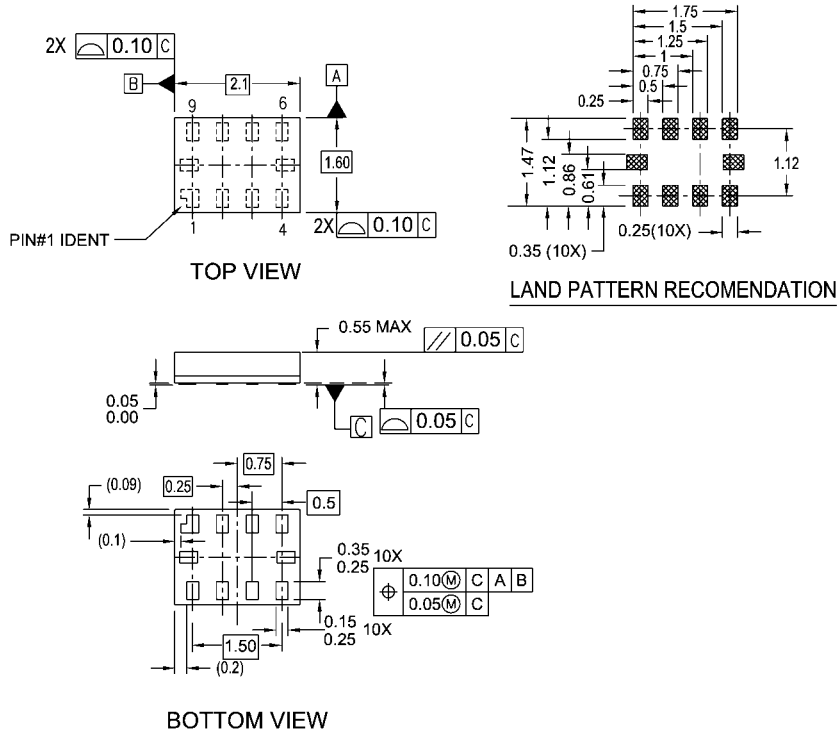

NOTES:

- A. PACKAGE CONFORMS TO JEDEC MO255, VARIATION UABD
- B. DIMENSIONS ARE IN MILLIMETERS.
- C. DIMENSIONS AND TOLERANCES CONFORMS TO ASME Y14.5M, 1994.

MAC010ARevB

Pb-Free 10-Lead MicroPak, 1.6 mm x 2.1mm
Package Number MAC010A

Physical Dimensions inches (millimeters) unless otherwise noted (Continued)

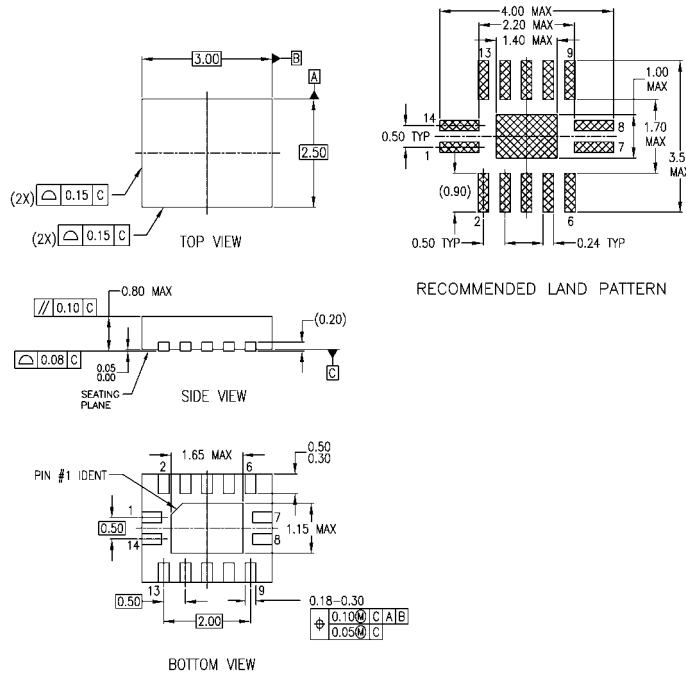

- NOTES:
- A. CONFORMS TO JEDEC REGISTRATION MO-241, VARIATION AA
 - B. DIMENSIONS ARE IN MILLIMETERS.
 - C. DIMENSIONS AND TOLERANCES PER ASME Y14.5M, 1994

MLP014ArevA

Pb-Free 14-Terminal Depopulated Quad Very-Thin Flat Pack No Leads (DQFN), JEDEC MO-241, 2.5 x 3.0mm Package Number MLP014A

Technology Description

The Fairchild Switch family derives from and embodies Fairchild's proven switch technology used for several years in its 74LVX3L384 (FST3384) bus switch product.

Fairchild does not assume any responsibility for use of any circuitry described, no circuit patent licenses are implied and Fairchild reserves the right at any time without notice to change said circuitry and specifications.

LIFE SUPPORT POLICY

FAIRCHILD'S PRODUCTS ARE NOT AUTHORIZED FOR USE AS CRITICAL COMPONENTS IN LIFE SUPPORT DEVICES OR SYSTEMS WITHOUT THE EXPRESS WRITTEN APPROVAL OF THE PRESIDENT OF FAIRCHILD SEMICONDUCTOR CORPORATION. As used herein:

1. Life support devices or systems are devices or systems which, (a) are intended for surgical implant into the body, or (b) support or sustain life, and (c) whose failure to perform when properly used in accordance with instructions for use provided in the labeling, can be reasonably expected to result in a significant injury to the user.
2. A critical component in any component of a life support device or system whose failure to perform can be reasonably expected to cause the failure of the life support device or system, or to affect its safety or effectiveness.

www.fairchildsemi.com