

## Applications

- Crystal-driven clock source

## General Description

The Vaishali VT73127 is a single-chip, low-jitter Voltage-Controlled-Crystal-Oscillator. The device accepts a 27 MHz, 20 pF crystal input, and produces a low jitter output at the same frequency. The output is enabled when OE is logic HIGH and goes into high impedance state when OE is logic LOW. A 0 to 3.0V control signal is used to fine tune the output clock frequency in the  $\pm 100$ ppm range.

## Features

- 3.3V operating voltage
- Uses inexpensive pullable crystals
- 12mA drive capability at TTL levels
- On-chip oscillator with 200 ppm pull range ( $\pm 100$  ppm)
- Active High output enable
- Die only

Figure 1. Functional Block Diagram

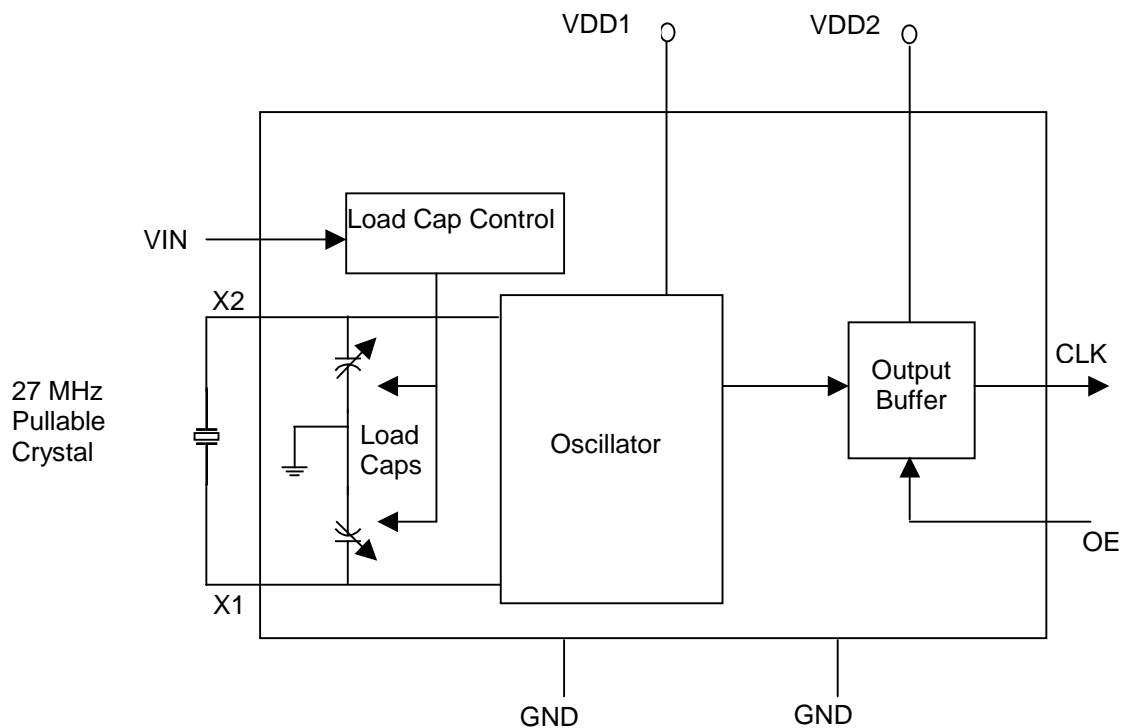

Figure 2. Pad Configuration

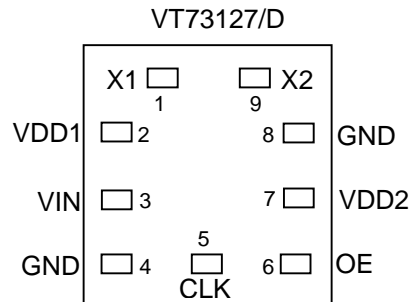

Table 1. Pad Description

Name	Pad	Type	Description
X1	1	Xi	Crystal connection. Connect to a 27 MHz pullable crystal
VDD1	2	P	Core $V_{DD}$ . Connect to 3.3V
VIN	3	I	Tuning control input. Zero to 3.3V signal controls the frequency of the VCXO.
GND	4	P	Connect to ground.
CLK	5	O	Clock output
OE	6	I	Active HIGH output enable. When LOW, the output is held in a tri-state condition
VDD2	7	P	Output buffer $V_{DD}$ . Connect to 3.3V
GND	8	P	Connect to ground.
X2	9	Xi	Crystal connection. Connect to a 27 MHz pullable crystal.

Legend: I = Input  
 O = Output  
 P = Power supply connection  
 Xi = Crystal connections.

Table 2. Absolute Maximum Ratings

Parameter	Conditions	Min	Typ	Max	Units
Supply voltage, $V_{DD}$	Referenced to GND			7	V
Inputs and Clock Outputs	Referenced to GND	-0.5		$V_{DD}+0.5$	V
Soldering Temperature	Max of 10 seconds			260	°C
Storage temperature		-65		150	°C

Stresses above those listed under Absolute Maximum Ratings may cause permanent damage to the device. These ratings are stress specifications only and correct functional operation of the device at these or any other conditions above those listed in the operational sections of the specifications is not implied. Exposure to absolute maximum rating conditions for extended periods may affect product reliability.

Table 3. Operating Conditions

Parameter	Conditions	Min	Typ	Max	Units
Operating Voltage, $V_{DD}$		3.0	3.3	3.6	V
Input High Voltage, $V_{IH}$ , X1 pin only		2.5			V
Input Low Voltage, $V_{IL}$ , X1 pin only				0.4	V
Operating Temperature		0		70	°C
Input crystal accuracy				±30	ppm

---

VCXO control voltage, $V_{IN}$		0		3.3	V
--------------------------------	--	---	--	-----	---

**Table 4. DC Electrical Characteristics**T<sub>A</sub> = 0°C to +70°C, V<sub>DD</sub> = 3.0 V to 3.6 V

Parameter	Condition	Min	Typ <sup>(1)</sup>	Max	Units
Output High Voltage, V <sub>OH</sub>	I <sub>OH</sub> =-12mA	2.4			V
Output Low Voltage, V <sub>OL</sub>	I <sub>OL</sub> =12mA			0.4	V
Operating Supply Current, I <sub>DD</sub>	No Load		25		mA
Short Circuit Current	Each output		±85		mA
Input Capacitance			7		pF

**Note:**1. Typical values are at V<sub>DD</sub> = 3.3V and 25°C**Table 5. AC Electrical Characteristics**T<sub>A</sub> = 0°C to +70°C, V<sub>DD</sub> = 3.0 V to 3.6 V

Symbol	Parameter	Condition	Min	Typ	Max	Units
fosc	Input Crystal Frequency			27		MHz
tr	Output Clock Rise Time	0.8 to 2.0V			1.5	ns
tf	Output Clock Fall Time	2.0 to 0.8V			1.5	ns
t <sub>PZL</sub> t <sub>PZH</sub>	Output Enable Time (OE to CLK)				6.5	ns
t <sub>PLZ</sub> t <sub>PHZ</sub>	Output Disable Time (OE to CLK)				6.5	ns
t <sub>od</sub>	Output Clock Duty Cycle	At V <sub>DD</sub> /2	40		60	%
t <sub>jit</sub> (pk – pk)	Maximum Absolute Jitter (Peak to Peak)				150	ps
	Output pullability	0V ≤ V <sub>IN</sub> ≤ 3.3V	±100			ppm

**Note:**1. Typical values are at V<sub>DD</sub> = 3.3V and 25°C**Table 6 Pullable Crystal Specifications**

Parameter	Symbol	Value
Correlation (Load) Capacitance	C <sub>L</sub>	20pF
Capacitance Ratio	C <sub>O</sub> /C <sub>1</sub>	240 max
ESR		50 Ω max
Initial Accuracy		±30ppm
Temperature and Aging Stability		±50ppm

**Ordering Information****VT73127**

Part Number	Marking	Shipping/Packaging	No. of Pads	Package	Temperature
VT73127/D		Dice in waffle-pack			0°C to +70°C
VT73127/DW		Dice in wafer form			0°C to +70°C