



12-BIT, 50MSPS, 150mW A/D CONVERTER

- **0.5MSPS to 50MSPS sampling frequency**
- 40mW @5MSPS, 150mW @ 50MSPS
- 2.5V supply voltage with 2.5V/3.3V compatibility for digital I/O
- Input range: 2Vpp differential
- SFDR up to 77dB @ 50MSPS, Fin=15MHz
- ENOB up to 10.5 bits @ 50MSPS, Fin=15MHz
- Built-in reference voltage with external bias capability
- Pinout compatibility with TSA0801, TSA1001 and TSA1002

DESCRIPTION

The TSA1201 is a 12-bit, 50MHz maximum sampling frequency Analog to Digital converter using a CMOS technology combining high performances and very low power consumption.

The TSA1201 is based on a pipeline structure and digital error correction to provide excellent static linearity and achieve 10.5 effective bits at $F_s=50\text{MSPS}$, and $F_{in}=15\text{MHz}$, with a global power consumption of 150mW.

The TSA1201 features adaptive behaviour to the application. Its architecture allows to sample from 0.5MSPS up to 50MSPS, with a programmable power consumption which makes the application board even more optimized.

It integrates a proprietary track-and-hold structure to ensure an high analog bandwidth of 1GHz and enable IF-sampling.

Several features are available on the device. A voltage reference is integrated in the circuit. Differential or single-ended analog inputs can be applied. The output data can be coded into two differential formats. A Data Ready signal is raised as the data is valid on the output and can be used for synchronization purposes.

The TSA1201 is available in extended (-40°C to +85°C) temperature range, in small 48 pins TQFP package.

APPLICATIONS

- High speed data acquisition
- Medical imaging and ultrasound
- Portable instrumentation
- High speed DSP interface
- Digital communication - IF sampling

ORDER CODE

Part Number	Temperature Range	Package	Conditioning	Marking
TSA1201IF	-40°C to +85°C	TQFP48	Tray	SA1201I
TSA1201IFT	-40°C to +85°C	TQFP48	Tape & Reel	SA1201I
EVAL1201/AA	Evaluation board			

PIN CONNECTIONS (top view)

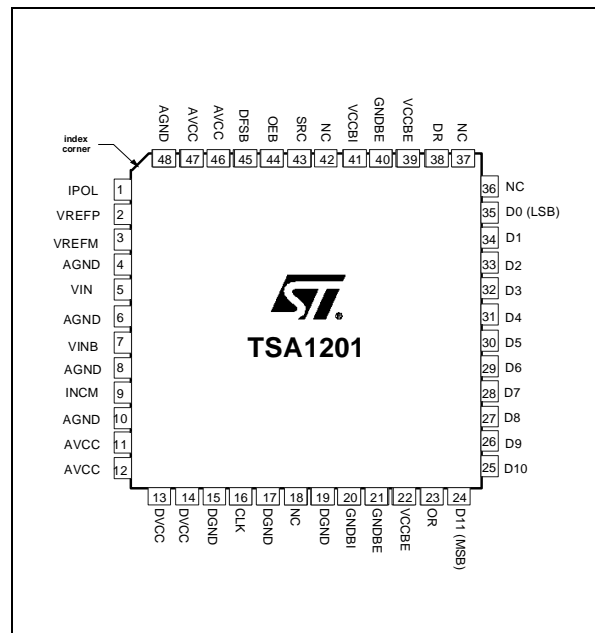

PACKAGE

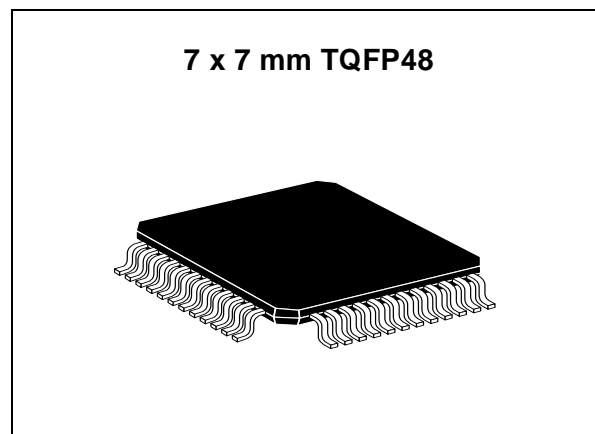

ABSOLUTE MAXIMUM RATINGS

Symbol	Parameter	Values	Unit
AVCC	Analog Supply voltage ¹⁾	0 to 3.3	V
DVCC	Digital Supply voltage ¹⁾	0 to 3.3	V
VCCBI	Digital buffer Supply voltage ¹⁾	0 to 3.3	V
VCCBE	Digital buffer Supply voltage ¹⁾	0 to 3.6	V
Tstg	Storage temperature	+150	°C
ESD	Electrical Static Discharge		
	- HBM - CDM-JEDEC Standard	2 1.5	KV

1. All voltages values, except differential voltage, are with respect to network ground terminal. The magnitude of input and output voltages must never exceed -0.3V or VCC+0V

OPERATING CONDITIONS

Symbol	Parameter	Test conditions	Min	Typ	Max	Unit
AVCC	Analog Supply voltage		2.25	2.5	2.7	V
DVCC	Digital Supply voltage		2.25	2.5	2.7	V
VCCBI	Internal (quiet) buffer Supply voltage		2.25	2.5	2.7	V
VCCBE	External (noisy) buffer Supply voltage		2.25	2.5	3.5	V
VREFP	Forced top voltage reference		0.8	-	AVCC	V
VREFM	Bottom internal reference voltage input		0		1	V

BLOCK DIAGRAM

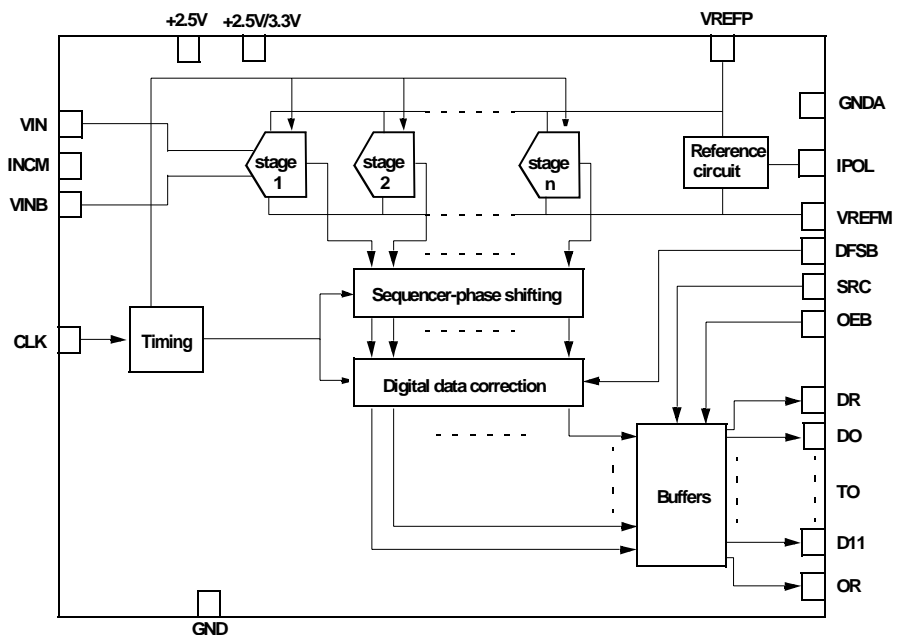

PIN CONNECTIONS (top view)

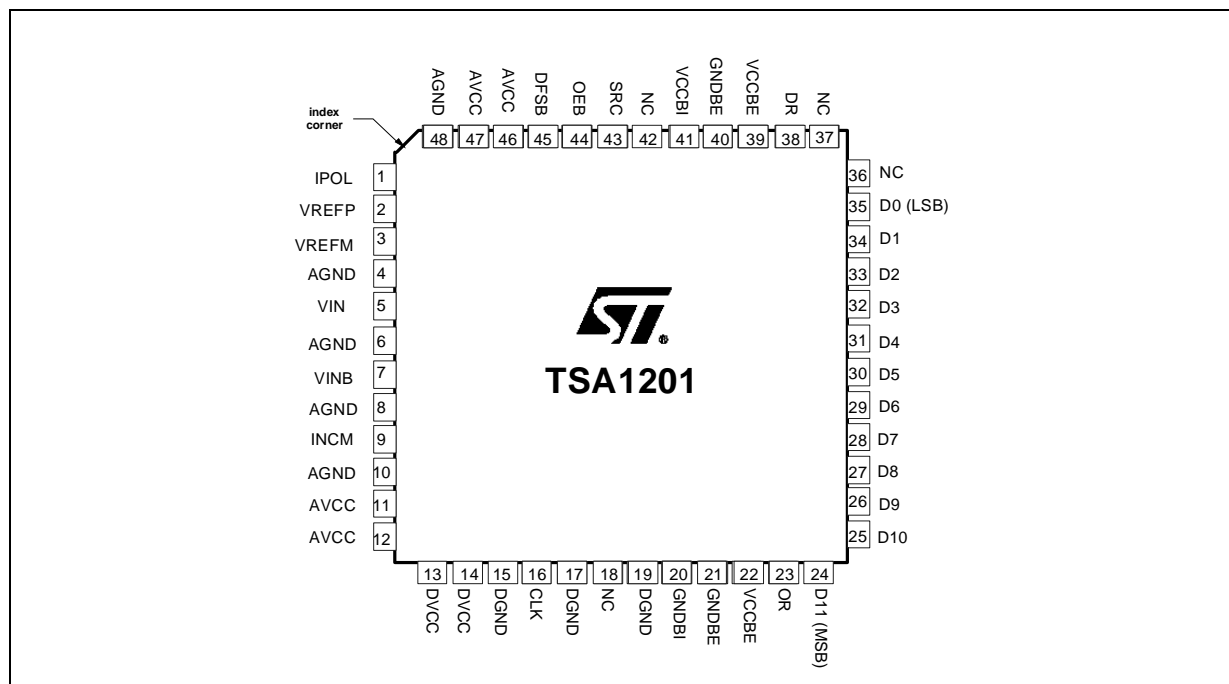

PIN DESCRIPTION

Pin No	Name	Description	Observation	Pin No	Name	Description	Observation
1	IPOL	Analog bias current input		25	D10	Digital output	CMOS output (2.5V/3.3V)
2	VREFP	Top voltage reference	1V	26	D9	Digital output	CMOS output (2.5V/3.3V)
3	VREFM	Bottom voltage reference	0V	27	D8	Digital output	CMOS output (2.5V/3.3V)
4	AGND	Analog ground	0V	28	D7	Digital output	CMOS output (2.5V/3.3V)
5	VIN	Analog input	1Vpp	29	D6	Digital output	CMOS output (2.5V/3.3V)
6	AGND	Analog ground	0V	30	D5	Digital output	CMOS output (2.5V/3.3V)
7	VINB	Inverted analog input	1Vpp	31	D4	Digital output	CMOS output (2.5V/3.3V)
8	AGND	Analog ground	0V	32	D3	Digital output	CMOS output (2.5V/3.3V)
9	INCM	Input common mode	0.5V	33	D2	Digital output	CMOS output (2.5V/3.3V)
10	AGND	Analog ground	0V	34	D1	Digital output	CMOS output (2.5V/3.3V)
11	AVCC	Analog power supply	2.5V	35	D0(LSB)	Least Significant Bit output	CMOS output (2.5V/3.3V)
12	AVCC	Analog power supply	2.5V	36	NC	Non connected	
13	DVCC	Digital power supply	2.5V	37	NC	Non connected	
14	DVCC	Digital power supply	2.5V	38	DR	Data Ready output	CMOS output (2.5V/3.3V)
15	DGND	Digital ground	0V	39	VCCBE	Digital Buffer power supply	2.5V/3.3V
16	CLK	Clock input	2.5V compatible CMOS input	40	GNDBE	Digital Buffer ground	0V
17	DGND	Digital ground	0V	41	VCCBI	Digital Buffer power supply	2.5V
18	NC	Non connected		42	NC	Non connected	
19	DGND	Digital ground	0V	43	SRC	Slew rate control input	2.5V/3.3V CMOS input
20	GNDBI	Digital buffer ground	0V	44	OEB	Output Enable input	2.5V/3.3V CMOS input
21	GNDBE	Digital buffer ground	0V	45	DFSB	Data Format Select input	2.5V/3.3V CMOS input
22	VCCBE	Digital buffer power supply	2.5V/3.3V	46	AVCC	Analog power supply	2.5V
23	OR	Out Of Range output	CMOS output (2.5V/3.3V)	47	AVCC	Analog power supply	2.5V
24	D11(MSB)	Most Significant Bit output	CMOS output (2.5V/3.3V)	48	AGND	Analog ground	0V

ELECTRICAL CHARACTERISTICS

AVCC = DVCC = VCCBE = VCCBI = 2.5V, Fs= 50Mps, Fin=2MHz, Vin@ -1dBFS, VREFM=0V
 Tamb = 25°C (unless otherwise specified)

TIMING CHARACTERISTICS

Symbol	Parameter	Test conditions	Min	Typ	Max	Unit
FS	Sampling Frequency		0.5		50	MHz
DC	Clock Duty Cycle		45	50	55	%
TC1	Clock pulse width (high)		9	10		ns
TC2	Clock pulse width (low)		9	10		ns
Tod	Data Output Delay (Fall of Clock to Data Valid)	6pF load capacitance		8		ns
Tpd	Data Pipeline delay			5.5		cycles
Ton	Falling edge of OEB to digital output valid data			1		ns
Toff	Rising edge of OEB to digital output tri-state			1		ns

TIMING DIAGRAM

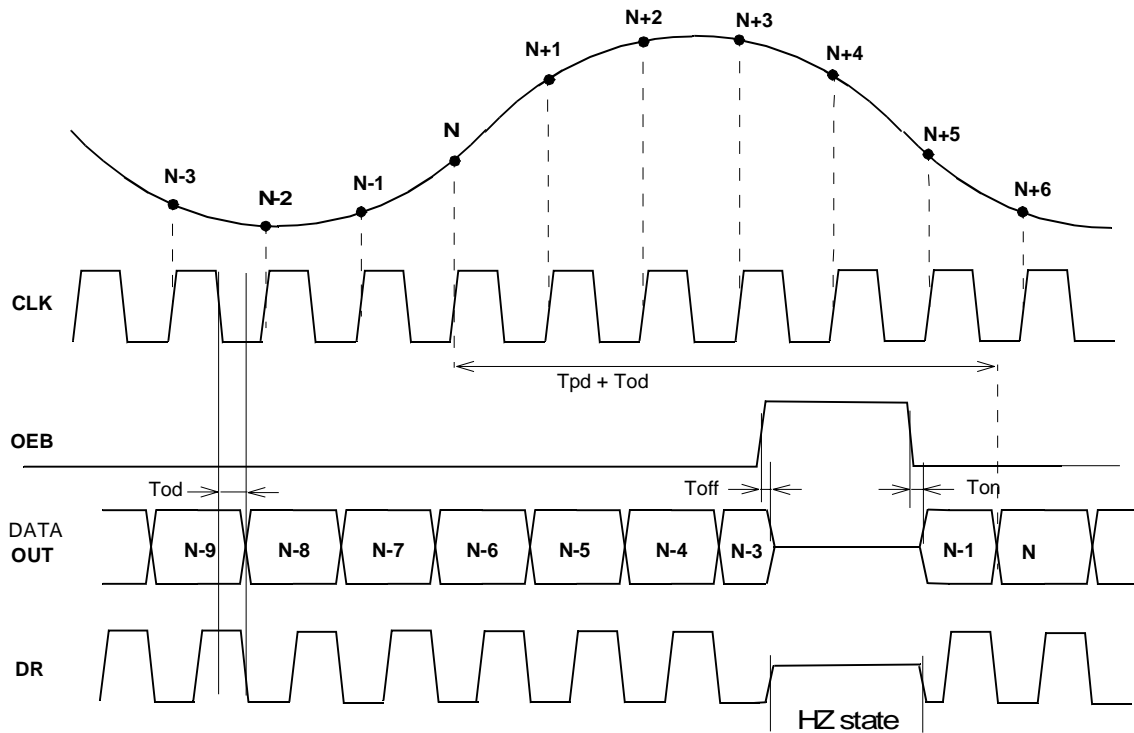

CONDITIONS

AVCC = DVCC = VCCBE = VCCBI = 2.5V, Fs= 50Mps, Fin=2MHz, Vin@ -1dBFS, VREFM=0V
 Tamb = 25°C (unless otherwise specified)

ANALOG INPUTS

Symbol	Parameter	Test conditions	Min	Typ	Max	Unit
VIN-VINB	Full scale reference voltage			2.0		Vpp
Cin	Input capacitance			7.0		pF
Rin	Differential input resistance			5		MΩ
BW	Analog Input Bandwidth	Vin@Full Scale, Fs=50Mps		1000		MHz
ERB	Effective Resolution Bandwidth ¹⁾			90		MHz

1. See parameters definition for more information.

REFERENCE VOLTAGE

Symbol	Parameter	Test conditions	Min	Typ	Max	Unit
VREFP	Top internal reference voltage		0.79	1.0	1.16	V
		Tmin= -40°C to Tmax= 85°C ¹⁾	0.79		1.16	V
Vpol	Analog bias voltage		1.08	1.15	1.22	V
		Tmin= -40°C to Tmax= 85°C ¹⁾	1.07		1.23	V
VINCM	Input common mode voltage		0.40	0.55	0.65	V
		Tmin= -40°C to Tmax= 85°C ¹⁾	0.4		0.65	V

1. Not fully tested over the temperature range. Guaranteed by sampling.

CONDITIONS

AVCC = DVCC = VCCBE = VCCBI = 2.5V, Fs= 50Mps, Fin=2MHz, Vin@ -1dBFS, VREFP=1V, VREFM=0V

Tamb = 25°C (unless otherwise specified)

POWER CONSUMPTION

Symbol	Parameter	Test conditions	Min	Typ	Max	Unit
Pd	Power consumption in normal operation mode	1)		150	158	mW
		Tmin= -40°C to Tmax= 85°C ²⁾			165	mW
ICCA	Analog Supply current	1)		46	51	mA
		Tmin= -40°C to Tmax= 85°C ²⁾			55	mA
ICCD	Digital Supply Current	1)		1.9	2.2	mA
		Tmin= -40°C to Tmax= 85°C ²⁾			2.2	mA
ICCB1	Digital Buffer Supply Current	1)		0.3	0.4	mA
		Tmin= -40°C to Tmax= 85°C ²⁾			0.4	mA
ICCB2	Digital Buffer Supply Current	1)		9.8	10.8	mA
		Tmin= -40°C to Tmax= 85°C ²⁾			10.8	mA
ICCBZ	Digital Buffer Supply Current in High Impedance Mode			4	5	mA
Rthja	Junction-ambient thermal resistance (TQFP48)			80		°C/W

1. Equivalent load: Rload= 470Ω and Cload= 6pF

2. Not fully tested over the temperature range. Guaranteed by sampling.

DIGITAL INPUTS AND OUTPUTS

Symbol	Parameter	Test conditions	Min	Typ	Max	Unit
Clock input						
VIL	Logic "0" voltage			0	0.8	V
VIH	Logic "1" voltage		2.0	2.5		V
Digital inputs						
VIL	Logic "0" voltage			0	0.25 x VCCBE	V
VIH	Logic "1" voltage		0.75 x VCCBE	VCCBE		V
Digital Outputs						
VOL	Logic "0" voltage	Iol=10μA		0	0.1 x VCCBE	V
VOH	Logic "1" voltage	Ioh=10μA	0.9 x VCCBE	VCCBE		V
IOZ	High Impedance leakage current	OEB set to VIH	-2.5		2.5	μA
CL	Output Load Capacitance				15	pF

CONDITIONS

AVCC = DVCC = VCCBE = VCCBI = 2.5V, Fs= 50Mps, Vin@ -1dBFS, VREFP=1V, VREFM=0V
 Tamb = 25°C (unless otherwise specified)

ACCURACY

Symbol	Parameter	Test conditions	Min	Typ	Max	Unit
OE	Offset Error	Fin= 2MHz, VIN@+1dBFS		2.45		mV
DNL	Differential Non Linearity	Fin= 2MHz, VIN@+1dBFS		±0.6		LSB
INL	Integral Non Linearity	Fin= 2MHz, VIN@+1dBFS		±1.7		LSB
-	Monotonicity and no missing codes		Guaranted			

DYNAMIC CHARACTERISTICS

Symbol	Parameter	Test conditions	Min	Typ	Max	Unit
SFDR	Spurious Free Dynamic Range	Fin= 15MHz ¹⁾		-77.2	-68	dBc
		Fin= 15MHz ²⁾			-67	dBc
SNR	Signal to Noise Ratio	Fin= 15MHz ¹⁾	61.6	64.9		dB
		Fin= 15MHz ²⁾	60.7			dB
THD	Total Harmonics Distorsion	Fin= 15MHz ¹⁾		-74.3	-68	dB
		Fin= 15MHz ²⁾			-64	dB
SINAD	Signal to Noise and Distorsion-Ratio	Fin= 15MHz ¹⁾	61	64.4		dB
		Fin= 15MHz ²⁾	60			dB
ENOB	Effective Number of Bits	Fin= 15MHz ¹⁾	10	10.5		bits
		Fin= 15MHz ²⁾	9.9			bits

1. Equivalent load: Rload= 470Ω and Cload= 6pF

2. Tmin= -40°C to Tmax= 85°C. Not fully tested over the temperature range. Guaranted by sampling.

DEFINITIONS OF SPECIFIED PARAMETERS**STATIC PARAMETERS**

Static measurements are performed through method of histograms on a 2MHz input signal, sampled at 50Msps, which is high enough to fully characterize the test frequency response. The input level is +1dBFS to saturate the signal.

Differential Non Linearity (DNL)

The average deviation of any output code width from the ideal code width of 1LSB.

Integral Non linearity (INL)

An ideal converter presents a transfer function as being the straight line from the starting code to the ending code. The INL is the deviation for each transition from this ideal curve.

DYNAMIC PARAMETERS

Dynamic measurements are performed by spectral analysis, applied to an input sinewave of various frequencies and sampled at 50Msps.

Spurious Free Dynamic Range (SFDR)

The ratio between the power of the worst spurious signal (not always an harmonic) and the amplitude of fundamental tone (signal power) over the full Nyquist band. It is expressed in dBc.

Total Harmonic Distortion (THD)

The ratio of the rms sum of the first five harmonic distortion components to the rms value of the fundamental line. It is expressed in dB.

Signal to Noise Ratio (SNR)

The ratio of the rms value of the fundamental component to the rms sum of all other spectral components in the Nyquist band ($f_s/2$) excluding DC, fundamental and the first five harmonics. SNR is reported in dB.

Signal to Noise and Distorsion Ratio (SINAD)

Similar ratio as for SNR but including the harmonic distortion components in the noise figure (not DC signal). It is expressed in dB.

From the SINAD, the Effective Number of Bits (ENOB) can easily be deduced using the formula: $SINAD = 6.02 \times ENOB + 1.76$ dB.

When the applied signal is not Full Scale (FS), but has an A_0 amplitude, the SINAD expression becomes:

$$SINAD = 6.02 \times ENOB + 1.76 \text{ dB} + 20 \log(2A_0/FS)$$

The ENOB is expressed in bits.

Analog Input Bandwidth

The maximum analog input frequency at which the spectral response of a full power signal is reduced by 3dB. Higher values can be achieved with smaller input levels.

Effective Resolution Bandwidth (ERB)

The band of input signal frequencies that the ADC is intended to convert without loosing linearity i.e. the maximum analog input frequency at which the SINAD is decreased by 3dB or the ENOB by 1/2 bit.

Pipeline delay

Delay between the initial sample of the analog input and the availability of the corresponding digital data output, on the output bus. Also called data latency. It is expressed as a number of clock cycles.

Static parameter: Integral Non Linearity

Fs=50MSPS; Fin=1MHz; Icca=45mA; N=131072pts

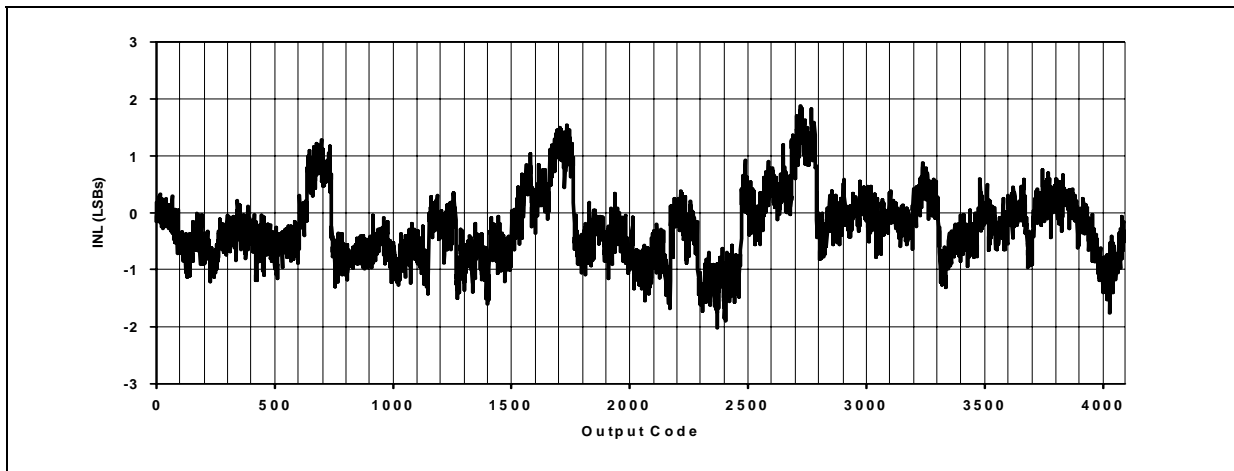

Static parameter: Differential Non Linearity

Fs=50MSPS; Fin=1MHz; Icca=45mA; N=131072pts

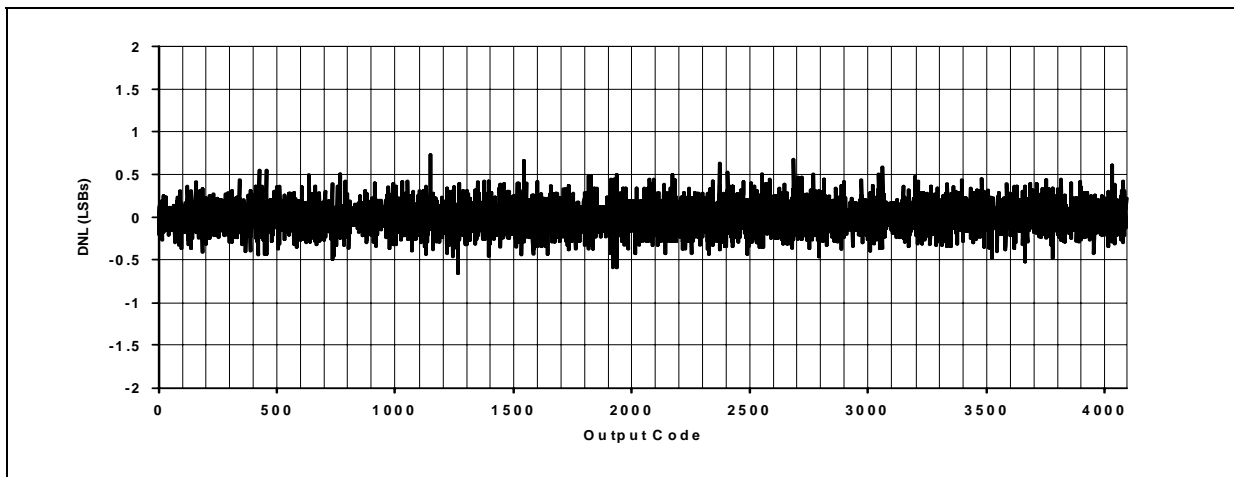

Linearity vs. VCCA

Fs=50MSPS; Icca=45mA; Fin=10MHz

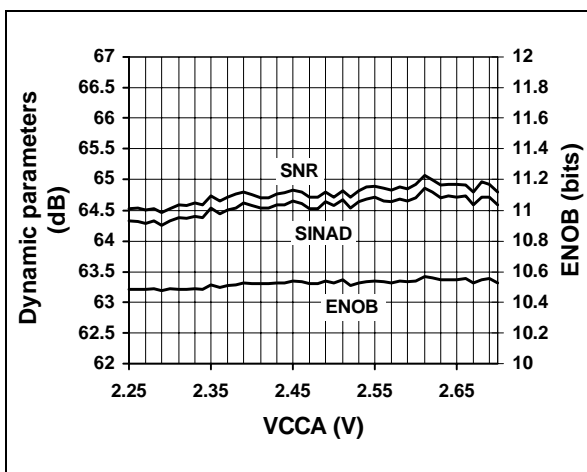

Distortion vs. VCCA

Fs=50MSPS; Icca=45mA; Fin=10MHz

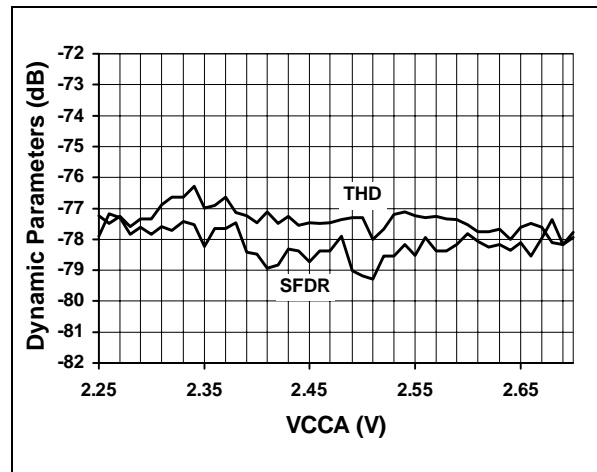

Linearity vs. VCCD

Fs=50MSPS; Icca=45mA; Fin=10MHz

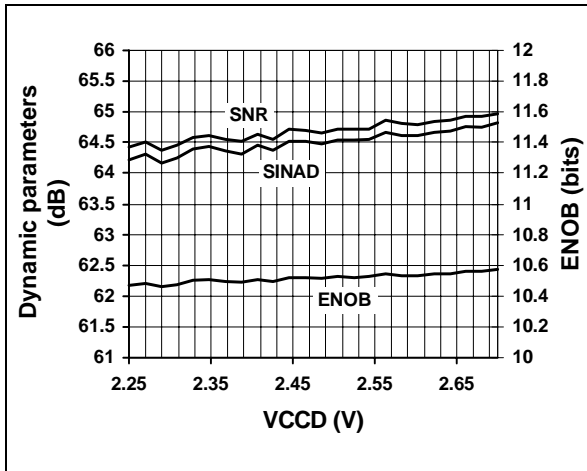

Distortion vs. VCCD

Fs=50MSPS; Icca=45mA; Fin=10MHz

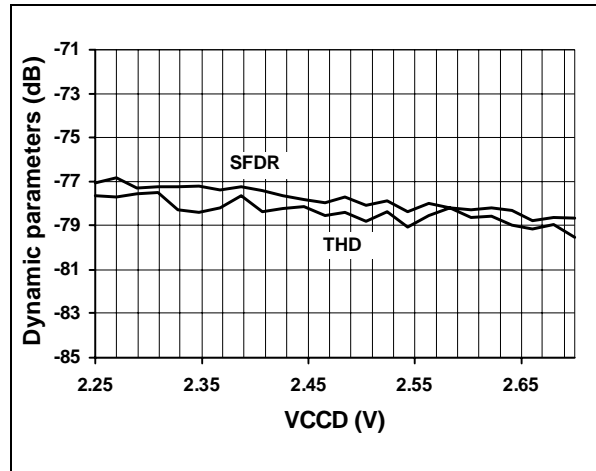

Linearity vs. VCCBE

Fs=50MSPS; Icca=45mA; Fin=10MHz

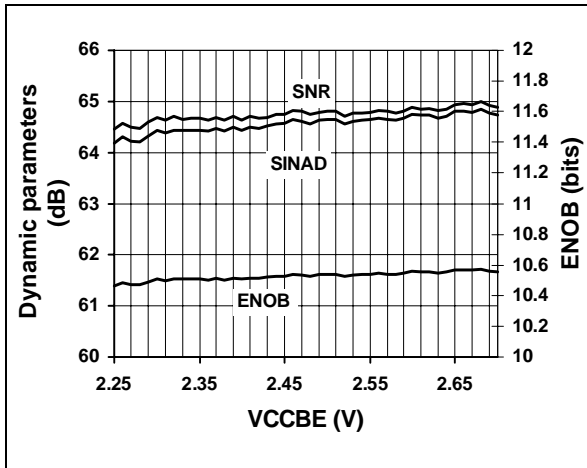

Distortion vs. VCCBE

Fs=50MSPS; Icca=45mA; Fin=10MHz

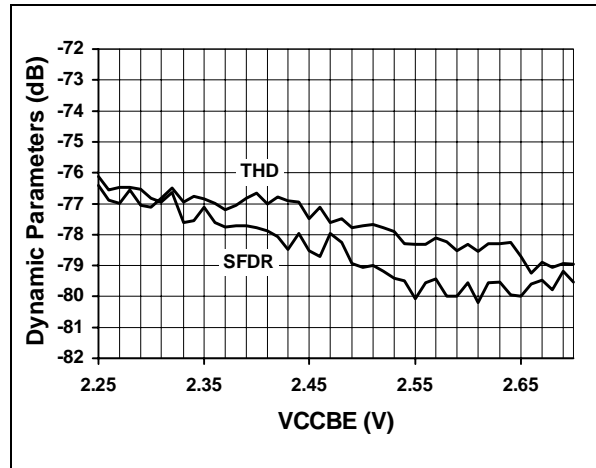

Linearity vs. Fs

Icca=45mA; Fin=10MHz

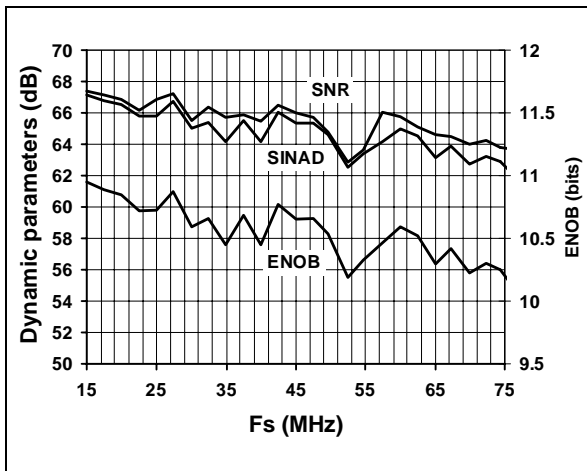

Distortion vs. Fs

Icca=45mA; Fin=10MHz

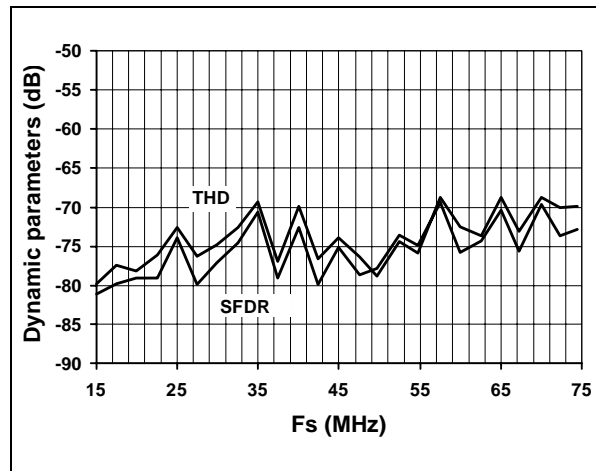

Linearity vs. Fin
 Fs=50MHz; Icca=45mA

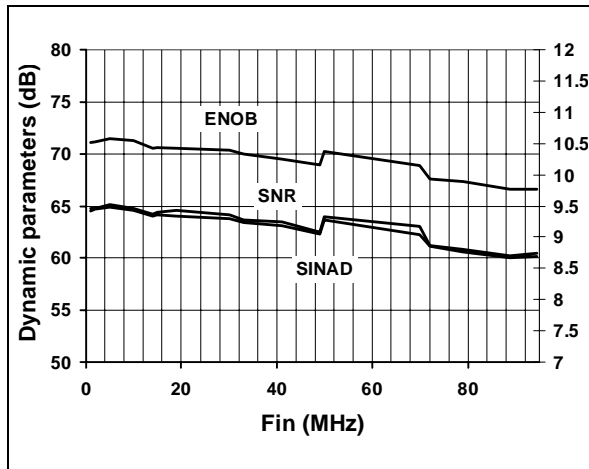

Distortion vs. Fin
 Fs=50MHz; Icca=45mA

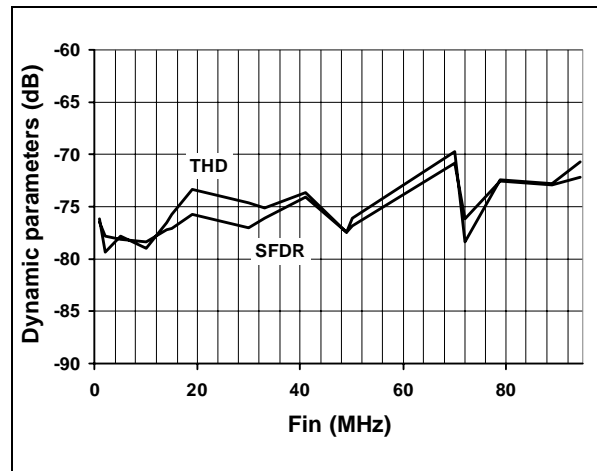

Linearity vs. Temperature
 Fs=49.7MSPS; Icca=45mA; Fin=15MHz

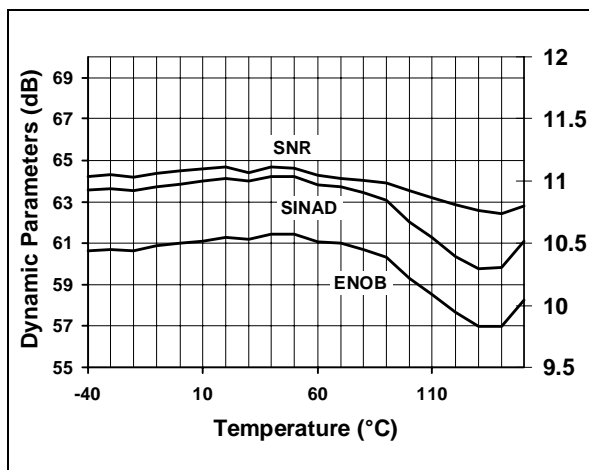

Distortion vs. Temperature
 Fs=49.7MSPS; Icca=45mA; Fin=15MHz

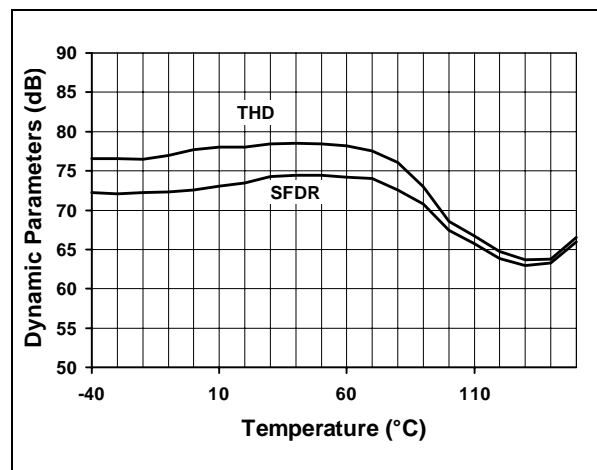

Single-tone 16K FFT at 50MSPS
 Fin=94.5MHz; Icca=45mA, Vin@-0.5dBFS

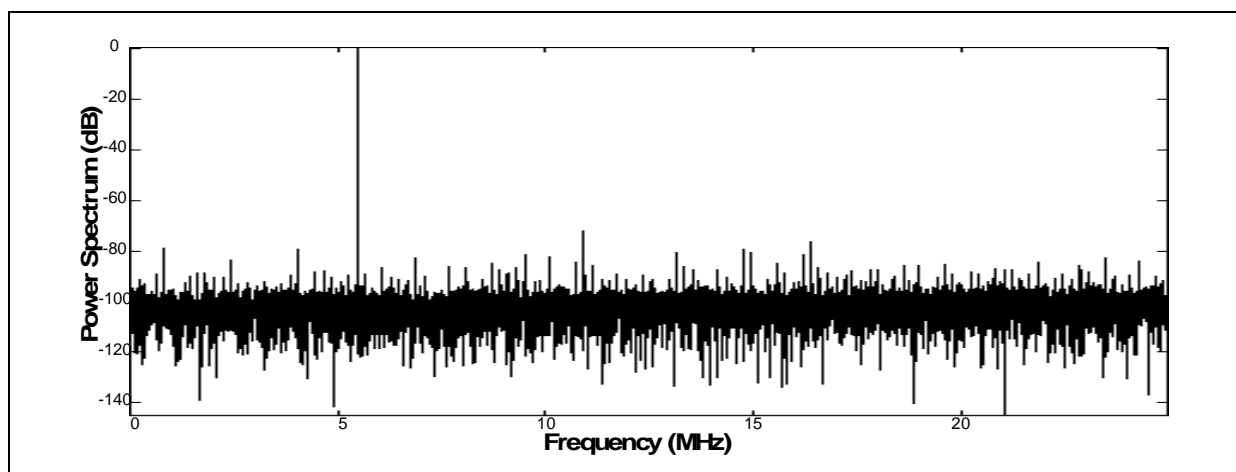

TSA1201 APPLICATION NOTE

DETAILED INFORMATION

The TSA1201 is a High Speed analog to digital converter based on a pipeline architecture and the latest deep submicron CMOS process to achieve the best performances in terms of linearity and power consumption.

The pipeline structure consists of 11 internal conversion stages in which the analog signal is fed and sequentially converted into digital data.

Each 10 first stages consists of an Analog to Digital converter, a Digital to Analog converter, a Sample and Hold and a gain of 2 amplifier. A 1.5-bit conversion resolution is achieved in each stage. The latest stage simply is a comparator. Each resulting LSB-MSB couple is then time shifted to recover from the delay caused by conversion. Digital data correction completes the processing by recovering from the redundancy of the (LSB-MSB) couple for each stage. The

corrected data are outputted through the digital buffers.

Signal input is sampled on the rising edge of the clock while digital outputs are delivered on the falling edge of the clock.

The advantages of such a converter reside in the combination of pipeline architecture and the most advanced technologies. The highest dynamic performances are achieved while consumption remains at the lowest level.

Some functionalities have been added in order to simplify as much as possible the application board. These operational modes are described in the following table.

The TSA1201 is pin to pin compatible with the 8bits/40Msps TSA0801, the 10bits/25Msps TSA1001 and the 10bits/50Msps TSA1002. This ensures a conformity with the product family and above all, an easy upgrade of the application

OPERATIONAL MODES DESCRIPTION

Inputs						Outputs		
Analog input differential level			DFSB	OEB	SRC	OR	DR	Most Significant Bit (MSB)
(VIN-VINB)	>	RANGE	H	L	X	H	CLK	D11
-RANGE	>	(VIN-VINB)	H	L	X	H	CLK	D11
RANGE>	(VIN-VINB)	>-RANGE	H	L	X	L	CLK	D11
(VIN-VINB)	>	RANGE	L	L	X	H	CLK	D11 Complemented
-RANGE	>	(VIN-VINB)	L	L	X	H	CLK	D11 Complemented
RANGE>	(VIN-VINB)	>-RANGE	L	L	X	L	CLK	D11 Complemented
X			X	H	X	HZ	HZ	HZ
X			X	X	H	X	CLK	25Msps compliant slew rate
X			X	X	L	X	CLK	50Msps compliant slew rate

Data Format Select (DFSB)

When set to low level (VIL), the digital input DFB provides a two's complement digital output MSB. This can be of interest when performing some further signal processing.

When set to high level (VIH), DFB provides a standard binary output coding.

Output Enable (OEB)

When set to low level (VIL), all digital outputs remain active and are in low impedance state. When set to high level (VIH), all digital outputs buffers are in high impedance state while the converter goes on sampling. When OEB is set to a low level again, the data are then present on the output with a very short T_{on} delay.

Therefore, this allows the chip select of the device. The timing diagram summarizes this functionality.

Slew Rate Control (SRC)

When set to high level (VIH), all digital outputs currents are limited to a clamp value so that digital noise power is reduced to its minimum. Rise and fall times just match 25MHz sampling rate assuming the load capacitance on each digital output remains below 10pF.

When set to low level (VIL), the maximum digital output current increases so that rise and fall times just match the 50MHz sampling rate assuming the load capacitance on each digital output remains below 10pF.

Out of Range (OR)

This function is implemented on the output stage in order to set up an "Out of Range" flag whenever the digital data is over the full scale range.

Typically, there is a detection of all the data being at '0' or all the data being at '1'. This ends up with an output signal OR which is in low level state (VOL) when the data stay within in the range, or in high level state (VOH) when the data are out of the range.

Data Ready (DR)

The Data Ready output is an image of the clock being synchronized on the output data (D0 to D11). This is a very helpful signal that simplifies the synchronization of the measurement equipment or the controlling DSP.

As digital output, DR goes into high impedance state when OEB is asserted to high level as described in the timing diagram.

DRIVING THE ANALOG INPUT

Differential inputs

The TSA1201 has been designed to obtain optimum performances when being differentially driven. An RF transformer is a good way to achieve such performances.

Figure 1 describes the schematics. The input signal is fed to the primary of the transformer, while the secondary drives both ADC inputs. The common mode voltage of the ADC (INCM) is connected to the center-tap of the secondary of the transformer in order to bias the input signal around this common voltage, internally set to 0.56V. It determines the DC component of the analog signal. As being an high impedance input, it acts as an I/O and can be externally driven to adjust this DC component. The INCM is decoupled to maintain a low noise level on this node. Our evaluation board is mounted with a 1:1 ADT1-1 transformer from Minicircuits. You might

also use a higher impedance ratio (1:2 or 1:4) to reduce the driving requirement on the analog signal source.

Each analog input can drive a 1Vpp amplitude input signal, so the resultant differential amplitude is 2Vpp.

Figure 1 : Differential input configuration

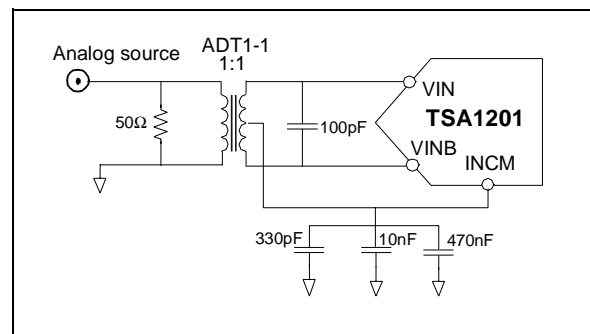

Single-ended input configuration

Some applications may require a single-ended input. This is easily achieved with the configuration reported on Figure 2 for an AC-coupled input or on Figure 3 and 4 for a DC-coupled input..

In the case of AC-coupled analog input, it is recommended to connect the other analog input to the common mode voltage of the circuit (INCM) so as to properly bias the ADC. The INCM may remain at the same internal level (0.56V) thus driving only a 1Vpp input amplitude, or it must be increased to 1V to drive a 2Vpp input amplitude.

Figure 2 : AC-coupled Single-ended input

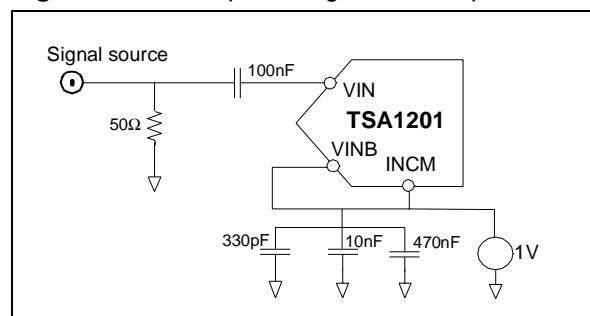

In the case of DC-coupled analog input, Figure 3 shows the configuration for a 2Vpp input signal. The DC component is driven by VREFP which is connected to INCM and VINB and therefore imposes its voltage. VREFM being connected to ground, a dynamic of 2Vpp is achievable.

Figure 4 describes the configuration for a 1Vpp analog signal. In this case, VREFM is connected

to VINB and INCM. The latest imposes its voltage. VREFP being internally set to 1V, the dynamic is then 1Vpp.

Figure 3 : DC-coupled 2Vpp analog input

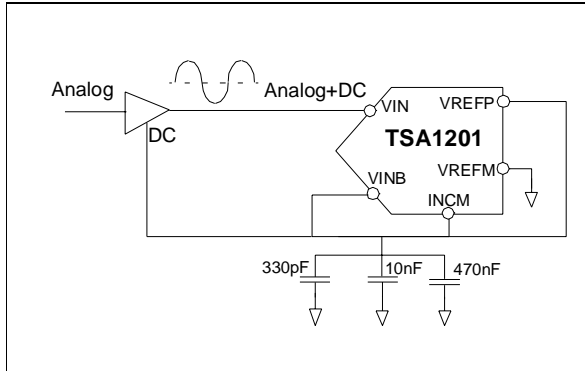
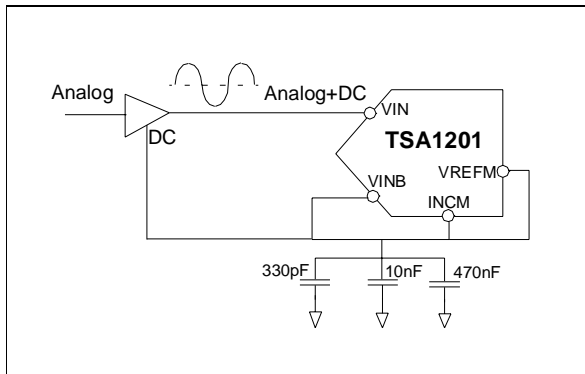

Figure 4 : DC-coupled 1Vpp analog input



IF-sampling

Software radio has become a common mode for receiving data through RF receivers. Its main advantage being to digitally implement what was originally done with analog functions such as discriminators, demodulation and filtering. Originally, bipolar process was mainly used because they provided high transistor transit frequency, while pure CMOS technology showed a lower one. With new CMOS process and circuit topology, higher frequencies are now achieved. The TSA1201 has been specifically designed to meet the requirement of sampling at Intermediate Frequency. For this purpose, the Track-and-Hold of the first pipeline stage has been built to ensure the global linearity of the overall ADC to perform the right characteristics. Our proprietary Track-and-Hold has a patented switch control system to enable the performances not to be degraded as input signal frequency increases. As a result, an analog bandwidth of 1GHz is achieved.

REFERENCE CONNECTION

Internal reference

In the standard configuration, the ADC is biased with the internal reference voltage. VREFM pin is connected to Analog Ground while VREFP is internally set to a voltage of 1.0V. It is recommended to decouple the VREFP in order to minimize low and high frequency noise. Refer to Figure 5 for the schematics.

Figure 5 : Internal reference setting

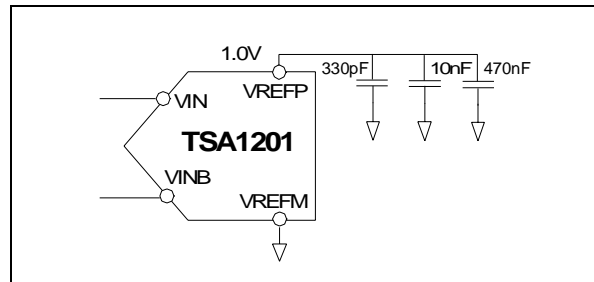

External reference

It is possible to use an external reference voltage instead of the internal one for specific applications requiring even better linearity or enhanced temperature behaviour. In this case, the amplitude of the external voltage must be at least equal to the internal one (1.0V). Using the STMicroelectronics Vref TS821 leads to optimum performances when configured as shown on Figure 6.

Figure 6 : External reference setting

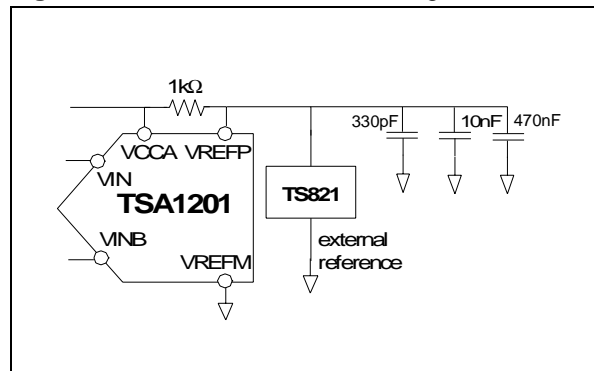

This can be very helpful for example for multichannel application to keep a good matching over the sampling frequency range.

Clock input

The quality of your converter is very dependant on your clock input accuracy, in terms of aperture jitter; the use of low jitter crystal controlled oscillator is recommended.

The duty cycle must be between 45% and 55%.

The clock power supplies must be separated from the ADC output ones to avoid digital noise modulation at the output.

It is recommended to always keep the circuit clocked, even at the lowest specified sampling frequency of 0.5MSPS, before applying the supply voltages.

Power consumption optimization

The internal architecture of the TSA1201 enables to optimize the power consumption according to the sampling frequency of. For this purpose, a resistor is placed between IPOL and the analog Ground pins. Therefore, the total dissipation is adjustable from 0.5MSPS up to 50MSPS. This feature is of highest importance when power saving conditions the application.

The TSA1201 will combine highest performances and lowest consumption at 50MSPS when Rpol is equal to 12kΩ.

At lower sampling frequency range, this value of resistor may be adjusted in order to decrease the analog current without any degradation of dynamic performances.

As an example, 40mW total power consumption is achieved at 5 MSPS with Rpol equal to 190kΩ and 35mW is dissipated at 1MSPS with Rpol equal to 350kΩ.

The table below sums up the relevant data.

Figure 7 describes the behaviour of the converter as sampling frequency increases and shows the optimum in terms of analog current and polarization resistor.

Total power consumption optimization depending on Rpol value

Fs (MSPS)	5	35	50
Rpol (kΩ)	190	29	12
Optimized power (mW)	40	100	150

Figure 7 : Optimized power consumption
Fin=1MHz

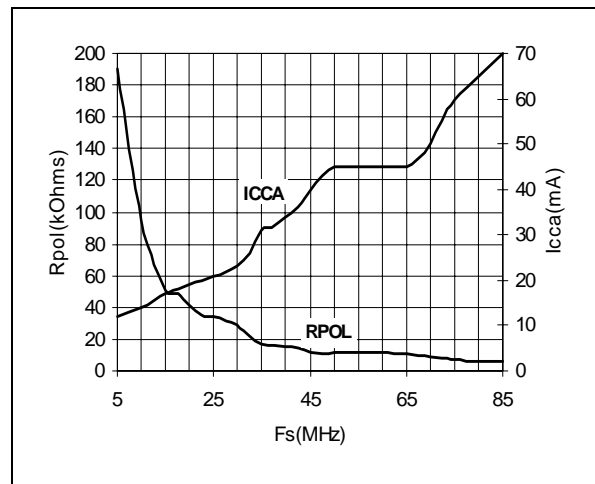

Layout precautions

To use the ADC circuits in the best manner at high frequencies, some precautions have to be taken for power supplies:

- First of all, the implementation of 4 separate proper supplies and ground planes (analog, digital, internal and external buffer ones) on the PCB is mandatory for high speed circuit applications to provide low inductance and low resistance common return.

The separation of the analog signal from the digital part is essential to prevent noise from coupling onto the input signal.

- Power supply bypass capacitors must be placed as close as possible to the IC pins in order to improve high frequency bypassing and reduce harmonic distortion.

- Proper termination of all inputs and outputs must be incorporated with output termination resistors; then the amplifier load will be only resistive and the stability of the amplifier will be improved. All leads must be wide and as short as possible especially for the analog input in order to decrease parasitic capacitance and inductance.

- To keep the capacitive loading as low as possible at digital outputs, short lead lengths of routing are essential to minimize currents when the output changes. To minimize this output capacitance, buffers or latches close to the output pins will relax this constraint.

- Choose component sizes as small as possible (SMD).

EVAL1201 evaluation board

The characterization of the board has been made with a fully ADC devoted test bench as shown on Figure 8. The analog signal must be filtered to be very pure.

The dataready signal is the acquisition clock of the logic analyzer.

The ADC digital outputs are latched by the octal buffers 74LCX573.

All characterization measurements have been made with:

- SFSR=+0.5dB for static parameters.
- SFSR=-0.5dB for dynamic parameters.

Figure 8 : Analog to Digital Converter characterization bench

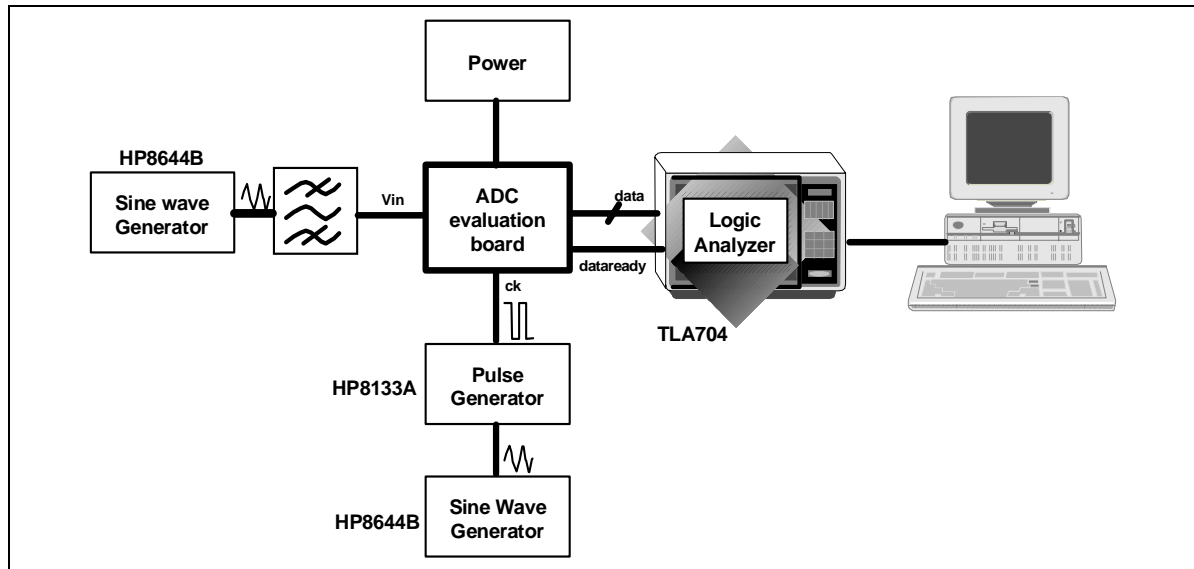

Figure 9 : TSA1201 Evaluation board schematic

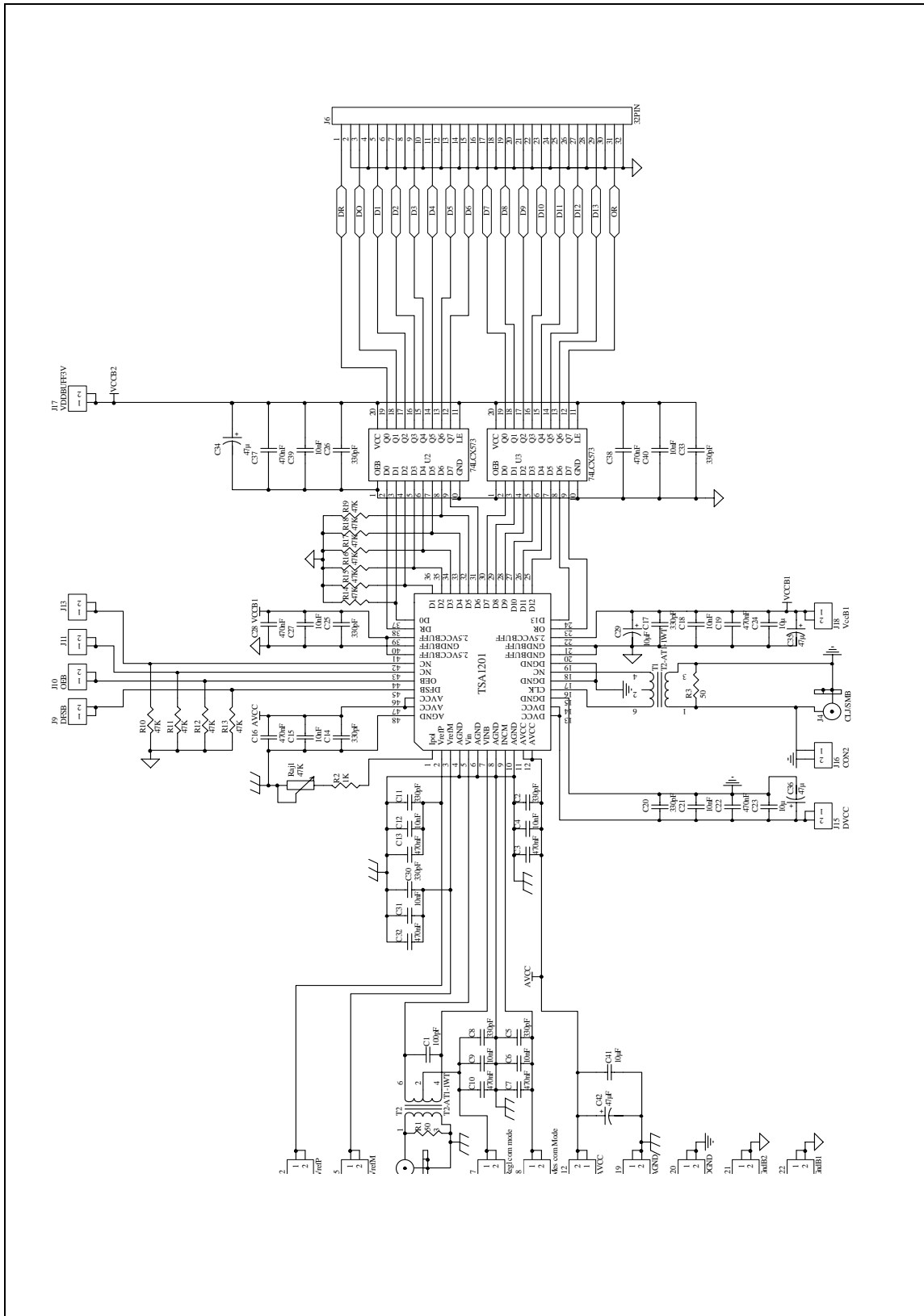
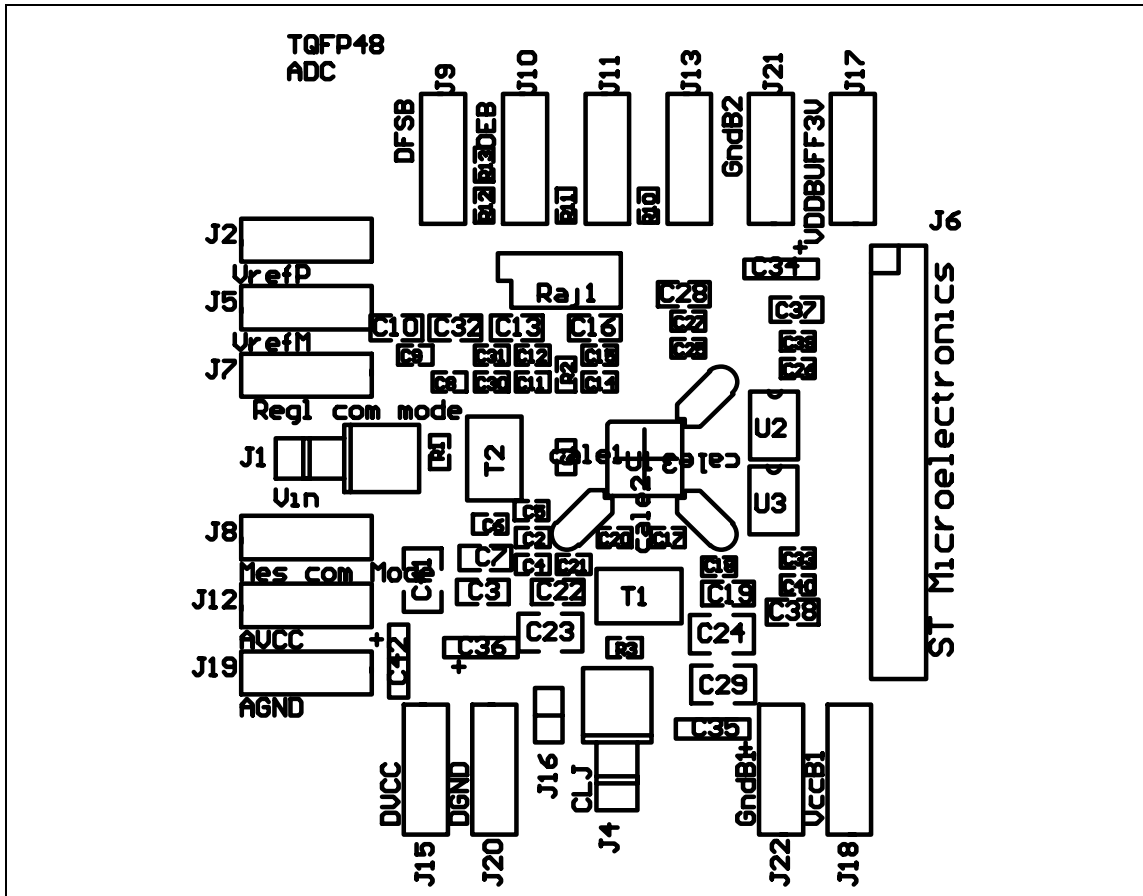

Figure 10 : Printed circuit of evaluation board.



Printed circuit board - List of components

Part	Design	Footprint	Part	Design	Footprint	Part	Design	Footprint	Part	Design	Footprint
Type	ator		Type	ator		Type	ator		Type	ator	
10uF	C24	1210	330pF	C33	603	470nF	C7	805	AVCC	J12	FICHE2MM
10uF	C23	1210	330pF	C20	603	470nF	C16	805	CLJ/SMB	J4	SMB/H
10uF	C41	1210	330pF	C8	603	470nF	C19	805	AGND	J19	FICHE2MM
10uF	C29	1210	330pF	C2	603	470nF	C3	805	DFSB	J9	FICHE2MM
100pF	C1	603	330pF	C5	603	47KΩ	R12	603	DGND	J20	FICHE2MM
10nF	C12	603	330pF	C11	603	47KΩ	R14	603	DVCC	J15	FICHE2MM
10nF	C39	603	330pF	C30	603	47KΩ	R11	603	GndB1	J22	FICHE2MM
10nF	C15	603	330pF	C17	603	47KΩ	R10	603	GndB2	J21	FICHE2MM
10nF	C40	603	330pF	C14	603	47KΩ	R19	603	Mes com mode	J8	FICHE2MM
10nF	C27	603	47uF	C36	CAP	47KΩ	R19	603	OEB	J10	FICHE2MM
10nF	C4	603	47uF	C34	CAP	47KΩ	R13	603	Regl com mode	J7	FICHE2MM
10nF	C21	603	47uF	C35	CAP	47KΩ	R15	603	T2-AT1-IWT	T2	ADT
10nF	C31	603	47uF	C42	CAP	47KΩ	R16	603	T2-AT1-IWT	T1	ADT
10nF	C6	603	470nF	C22	805	47KΩ	R17	603	VccB1	J18	FICHE2MM
10nF	C9	603	470nF	C32	805	47KΩ	R18	603	VDDBUFF3V	J17	FICHE2MM
10nF	C18	603	470nF	C37	805	50Ω	R3	603	Vin	J1	SMB/H
1KΩ	R2	603	470nF	C38	805	50Ω	R1	603	VrefM	J5	FICHE2MM
32PIN	J6	IDC32	470nF	C13	805	74LCX573	U3	TSSOP20	VrefP	J2	FICHE2MM
330pF	C25	603	470nF	C28	805	74LCX573	U2	TSSOP20	TSA1201	U1	TQFP48
330pF	C26	603	470nF	C10	805	CON2	J16	SIP2			

PACKAGE MECHANICAL DATA
48 PINS - PLASTIC PACKAGE

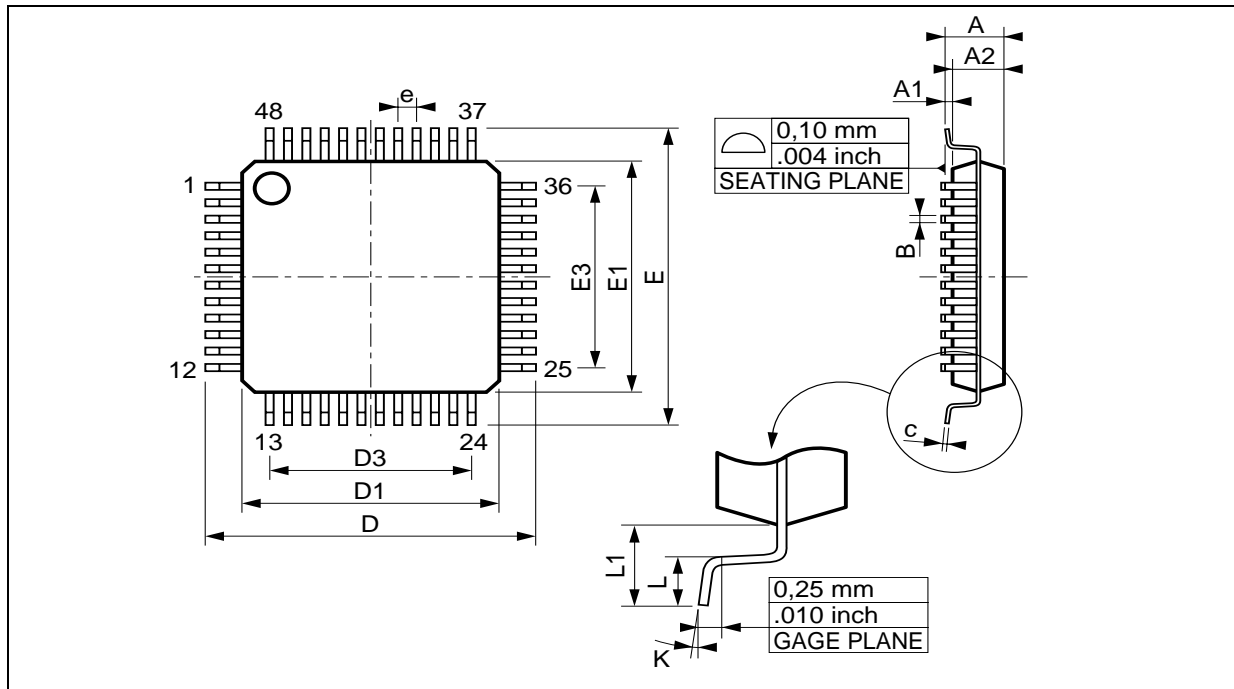

Dim.	Millimeters			Inches		
	Min.	Typ.	Max.	Min.	Typ.	Max.
A			1.60			0.063
A1	0.05		0.15	0.002		0.006
A2	1.35	1.40	1.45	0.053	0.055	0.057
B	0.17	0.22	0.27	0.007	0.009	0.011
C	0.09		0.20	0.004		0.008
D		9.00			0.354	
D1		7.00			0.276	
D3		5.50			0.216	
e		0.50			0.0197	
E		9.00			0.354	
E1		7.00			0.276	
E3		5.50			0.216	
L	0.45	0.60	0.75	0.018	0.024	0.030
L1		1.00			0.039	
K	0° (min.), 7° (max.)					

Information furnished is believed to be accurate and reliable. However, STMicroelectronics assumes no responsibility for the consequences of use of such information nor for any infringement of patents or other rights of third parties which may result from its use. No license is granted by implication or otherwise under any patent or patent rights of STMicroelectronics. Specifications mentioned in this publication are subject to change without notice. This publication supersedes and replaces all information previously supplied. STMicroelectronics products are not authorized for use as critical components in life support devices or systems without express written approval of STMicroelectronics.

© The ST logo is a registered trademark of STMicroelectronics

© 2001 STMicroelectronics - Printed in France - All Rights Reserved
STMicroelectronics GROUP OF COMPANIES

Australia - Brazil - China - Finland - France - Germany - Hong Kong - India - Italy - Japan - Malaysia - Malta - Morocco
Singapore - Spain - Sweden - Switzerland - United Kingdom

© <http://www.st.com>

