

# INFRARED LED

T:41-11

## MTE1100 GaAs INFRARED EMITTER INFRARED LED FOR PHOTO SENSOR

### APPLICATIONS

- REMOTE CONTROL SYSTEM
- OPTICAL SWITCH

### FEATURES

- Output spectrally compatible with silicon sensor MTD7030.
- High radiant power.
- High radiant intensity:  $I_E = 30\text{mW / sr}$ .

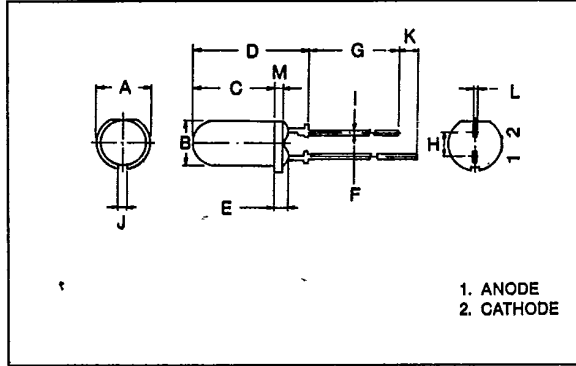

1. ANODE  
2. CATHODE

SYMBOL	INCHES	MM
A	0.228 ± 0.008	5.8 ± 0.2
B	0.197 ± 0.008	5 ± 0.2
C	0.341 ± 0.008	8.65 ± 0.2
D	0.478 ± 0.016	12.15 ± 0.4
E	0.100 MAX	2.5 MAX
F	0.020	0.5
G	0.691 ± 0.039	17.5 ± 1
H	0.100	2.54
I	0.020	0.5
J	0.039	1.0
K	0.079	2.0
L	0.020	0.5
M	0.039	1.0

### MAXIMUM RATINGS (Ta = 25°C)

CHARACTERISTIC	SYMBOL	RATING	UNIT
Forward Current	$I_F$	100	mA
Pulse Forward Current (Note)	$I_{FP}$	1	A
Reverse Voltage	$V_R$	5	V
Diode Power Dissipation	$P_D$	150	mW
Operating Temperature Range	$T_{opr}$	-20 ~ 75	°C
Storage Temperature Range	$T_{stg}$	-30 ~ 100	°C

Note: Pulse width ≤ 100μs. Repetitive frequency=100Hz.

### OPTO-ELECTRICAL CHARACTERISTICS (Ta=25°C)

CHARACTERISTIC	SYMBOL	TEST CONDITION	MIN.	TYP.	MAX.	UNIT
Forward Voltage	$V_F$	$I_F = 100\text{mA}$	—	1.35	1.5	V
Reverse Current	$I_R$	$V_R = 5\text{V}$	—	—	10	μA
Radiant Intensity	$I_E$	$I_F = 50\text{mA}$	15	30	—	mW / sr
Radiant Power	$P_O$	$I_F = 50\text{mA}$	—	9	—	mW
Capacitance	$C_T$	$V_R = 0, f = 1\text{MHz}$	—	20	—	pF
Peak Emission Wave Length	$\lambda_P$	$I_F = 50\text{mA}$	—	940	—	nm
Spectral Line Half Width	$\Delta\lambda$	$I_F = 50\text{mA}$	—	45	—	nm

# INFRARED LED

T-41-11

