

TOSHIBA BIPOLAR LINEAR INTEGRATED CIRCUIT SILICON MONOLITHIC

TA2111N, TA2111F, TA2111FN**3V AM / FM 1 CHIP TUNER IC**

TA2111N/F/FN are AM/FM 1 chip tuner ICs, which are designed for portable Radios and 3V Head phone Radios. FM Local Oscillation Voltage is set up low relativity, for NEW FCC.

FEATURES

- For NEW FCC.
- AM Detector Coil, FM IFT, IF Coupling Condenser are not needed.
- For adopting Ceramic Discriminator, it is not necessary to adjust the FM Quad Detector Circuit.
- Built-in FM MPX VCO circuit.
- Built-in varactor diode for AFC.
- Built-in AM Low cut circuit.
- Low supply current. ($V_{CC} = 3V$, $T_a = 25^\circ C$)
 - I_{CCq} (FM) = 9.0mA (Typ.)
 - I_{CCq} (AM) = 5.0mA (Typ.)
- Operating Supply voltage range : $V_{CC} = 1.8 \sim 7V$ ($T_a = 25^\circ C$)
 - (*) Handle with care to prevent devices from deteriorations by static electricity.

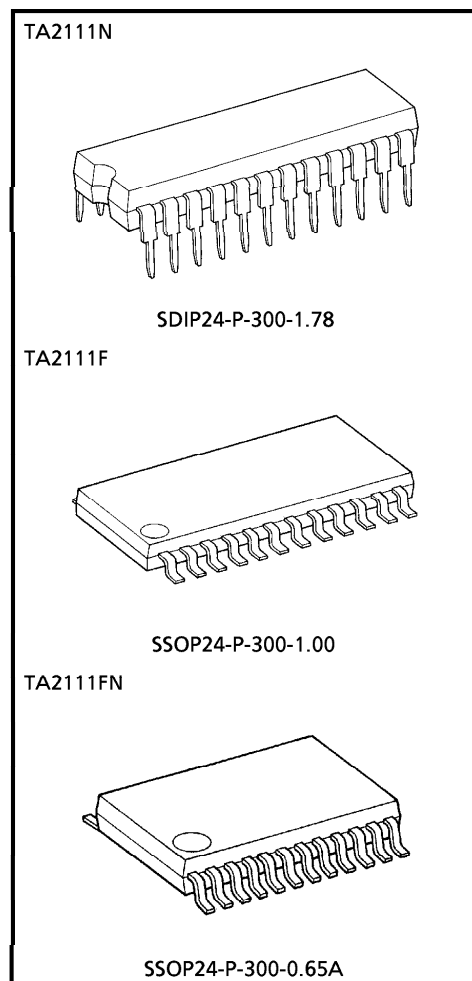
**Weight**

SDIP24-P-300-1.78 : 1.2g (Typ.)
 SSOP24-P-300-1.00 : 0.31g (Typ.)
 SSOP24-P-300-0.65A : 0.14g (Typ.)

980910EBA1

- TOSHIBA is continually working to improve the quality and the reliability of its products. Nevertheless, semiconductor devices in general can malfunction or fail due to their inherent electrical sensitivity and vulnerability to physical stress. It is the responsibility of the buyer, when utilizing TOSHIBA products, to observe standards of safety, and to avoid situations in which a malfunction or failure of a TOSHIBA product could cause loss of human life, bodily injury or damage to property. In developing your designs, please ensure that TOSHIBA products are used within specified operating ranges as set forth in the most recent products specifications. Also, please keep in mind the precautions and conditions set forth in the TOSHIBA Semiconductor Reliability Handbook.
- The products described in this document are subject to the foreign exchange and foreign trade laws.
- The information contained herein is presented only as a guide for the applications of our products. No responsibility is assumed by TOSHIBA CORPORATION for any infringements of intellectual property or other rights of the third parties which may result from its use. No license is granted by implication or otherwise under any intellectual property or other rights of TOSHIBA CORPORATION or others.
- The information contained herein is subject to change without notice.

BLOCK DIAGRAM

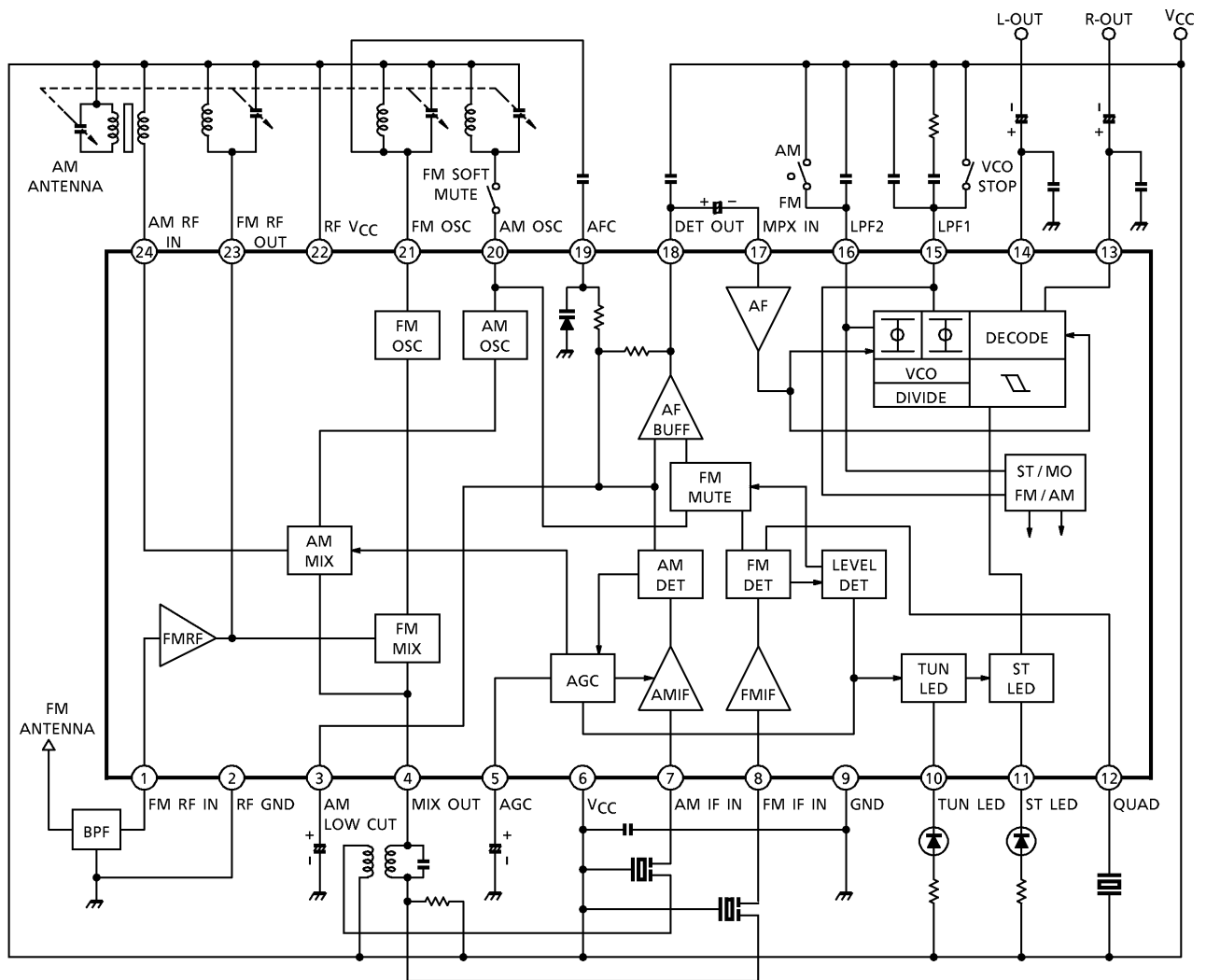

EXPLANATION OF TERMINALS

(Terminal voltage : Typical terminal voltage at no signal with test circuit, $V_{CC} = 3V$, $T_a = 25^\circ C$)

PIN No.	CHARACTERISTIC	INTERNAL CIRCUIT	TERMINAL VOLTAGE (Typ.) (V)	
			AM	FM
1	FM-RF IN		0	0.8
2	RF GND (GND for FM RF, FM OSC stage)	—	0	0
3	AM LOW CUT		1.0	0.8
4	MIX OUT		3.0	2.9
5	AGC (AM AGC)		0	0
6	V_{CC} (V_{CC} for AM, FM IF, FM MPX stage)	—	3.0	3.0

PIN No.	CHARACTERISTIC	INTERNAL CIRCUIT	TERMINAL VOLTAGE (Typ.) (V)	
			AM	FM
7	AM IF IN		2.3	2.6
8	FM IF IN		3.0	3.0
9	GND (GND for AM, FM IF, FM MPX stage)	—	0	0
10	TUN LED (Tuning LED)		—	—
11	ST LED (Stereo LED)		—	—
12	QUAD (FM QUAD. Detector)		2.5	2.2

PIN No.	CHARACTERISTIC	INTERNAL CIRCUIT	TERMINAL VOLTAGE (Typ.) (V)	
			AM	FM
13 14	R-OUT (R-ch Output) L-OUT (L-ch Output)		1.2	1.2
15	LPF1 <ul style="list-style-type: none"> ● LPF terminal for synchronous Detector ● VCO stop terminal V15 = V_{CC} → VCO STOP 		2.3	2.3
16	LPF2 <ul style="list-style-type: none"> ● LPF terminal for phase Detector ● Bias terminal for AM / FM SW circuit V16 = V_{CC} → AM V16 = OPEN → FM 		3	2.2
17	MPX IN		0.7	0.7

PIN No.	CHARACTERISTIC	INTERNAL CIRCUIT	TERMINAL VOLTAGE (Typ.) (V)	
			AM	FM
18	DET OUT	<p>① LOW→FM, HIGH→AM ② LOW→AM, HIGH→FM</p>	1.0	0.9
19	AFC	cf. pin ③	—	—
20	AM OSC		3.0	3.0
21	FM OSC		3.0	3.0
22	RF V _{CC} (V _{CC} for FM OSC stage)	—	3.0	3.0
23	FM RF OUT	cf. pin ①	3.0	3.0

PIN No.	CHARACTERISTIC	INTERNAL CIRCUIT	TERMINAL VOLTAGE (Typ.) (V)	
			AM	FM
24	AM RF IN		3.0	3.0

APPLICATION NOTE

1. AM Low-Cut Circuit

- The AM Low-Cut action is carried out by the bypass of the high frequency component of the positive-feedback signal at the AF AMP stage. The external capacitor : C₃ by-passes this component.
- The cut-off frequency f_L is determined by the internal resistance 10kΩ (Typ.) and the external capacitor C₃ as following ;

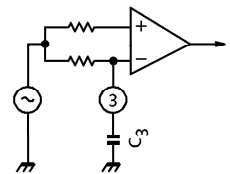

$$f_L = \frac{1}{2 \times \pi \times 10 \times 10^3 \times C_3} \text{ (Hz)}$$

- In the case of the AM Low-Cut function is not needed, set up the value of C₃ over 1μF. In the condition of C₃ ≥ 1μF, the frequency characteristic has flat response at the low frequency.
- In FM mode, C₃ is a Capacitor for AFC Low-Pass filter circuit.

2. FM Detection Circuit

For the FM detection circuit, detection coil is able to use instead of ceramic discriminator. Recommended circuit and recommended coil are as follows. In this case, please take care that V_{in} (lim.) falls a little.

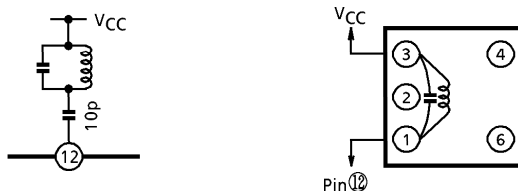

TEST FREQUENCY	C ₀ (pF)	Q ₀	TURNS				WIRE (mm φ)	REFERENCE
			1-2	2-3	1-3	4-6		
10.7MHz	51	45	—	—	30	—	0.12 UEW	TOKO Co., Ltd. 600BEAS-10018Z

MAXIMUM RATINGS (Ta = 25°C)

CHARACTERISTIC		SYMBOL	RATING	UNIT
Supply Voltage		V _{CC}	8	V
LED Current		I _{LED}	10	mA
LED Voltage		V _{LED}	8	V
Power Dissipation	TA2111N	P _D (Note)	1200	mW
	TA2111F		400	
	TA2111FN		500	
Operating Temperature		T _{opr}	- 25~75	°C
Storage Temperature		T _{stg}	- 55~150	°C

(Note) Derated above Ta = 25°C in the proportion of 9.6mW/°C for TA2111N, of 3.2mW/°C for TA2111F and of 4mW/°C for TA2111FN.

ELECTRICAL CHARACTERISTICS

Unless otherwise specified, Ta = 25°C, V_{CC} = 3V, F/E : f = 98MHz, f_m = 1kHz
 FM IF : f = 10.7MHz, Δf = ± 22.5kHz, f_m = 1kHz
 AM : f = 1MHz, MOD = 30%, f_m = 1kHz
 MPX : f_m = 1kHz

CHARACTERISTIC		SYMBOL	TEST CIRCUIT	TEST CONDITION	MIN.	TYP.	MAX.	UNIT
Supply Current		I _{CC} (FM)	1	V _{in} = 0, FM mode	—	9	12.5	mA
		I _{CC} (AM)	1	V _{in} = 0, AM mode	—	5	7.5	
F/E	Input Limiting Voltage	V _{in} (lim)	1	- 3dB limiting	—	7	—	dB _μ V EMF
	Local OSC Voltage	V _{OSC}	2	f _{OSC} = 108.7MHz	—	105	—	mV _{rms}
FM IF	Input Limiting Voltage	V _{in} (lim) IF	1	- 3dB limiting	35	40	45	dB _μ V EMF
	Recovered Output Voltage	V _{OD}	1	V _{in} = 80dB _μ V EMF	60	75	90	mV _{rms}
	Signal To Noise Ratio	S/N	1	V _{in} = 80dB _μ V EMF	—	65	—	dB
	Total Harmonic Distortion	THD	1	V _{in} = 80dB _μ V EMF	—	0.2	—	%
	AM Rejection Ration	AMR	1	V _{in} = 80dB _μ V EMF	—	50	—	dB
	LED On Sensitivity	V _L	1	I _L = 1mA	40	45	50	dB _μ V EMF
	Soft Mute Attenuation	MUTE	1	V _{in} = 0	—	20	—	dB
AM	Gain	G _V	1	V _{in} = 25dB _μ V EMF	18	35	70	mV _{rms}
	Recovered Output Voltage	V _{OD}	1	V _{in} = 60dB _μ V EMF	50	70	90	mV _{rms}
	Signal To Noise Ratio	S/N	1	V _{in} = 60dB _μ V EMF	—	41	—	dB
	Total Harmonic Distortion	THD	1	V _{in} = 60dB _μ V EMF	—	0.7	—	%
	LED On Sensitivity	V _L	1	I _L = 1mA	23	28	33	dB _μ V EMF
Pin 18 Output Resistance	R ₁₈	—	FM mode	—	0.75	—	kΩ	
			AM mode	—	15.5	—		

CHARACTERISTIC		SYMBOL	TEST CIRCUIT	TEST CONDITION	MIN.	TYP.	MAX.	UNIT	
MPX	Input Resistance	R _{IN}	—	—	—	55	—	kΩ	
	Output Resistance	R _{OUT}	—	—	—	5	—	kΩ	
	Max. Composite Signal Input Voltage	V _{in} MAX (STEREO)	1	L + R = 90%, P = 10%, f _m = 1kHz, THD = 3%	—	700	—	mV _{rms}	
	Separation	Sep	1	L + R = 180mV _{rms} , P = 20mV _{rms}	f _m = 100Hz — f _m = 1kHz 35 f _m = 10kHz —	45 — 45 —	— — — —	dB	
	Total Harmonic Distortion	Monaural	THD (MONAURAL)	1	V _{in} = 200mV _{rms}	—	0.3	—	%
		Stereo	THD (STEREO)	1	L + R = 180mV _{rms} , P = 20mV _{rms}	—	0.3	—	
	Voltage Gain	G _V	1	V _{in} = 200mV _{rms}	- 2.5	- 1	0.5	dB	
	Channel Balance	C.B.	1	V _{in} = 200mV _{rms}	- 1.5	0	1.5	dB	
	Stereo LED Sensitivity	ON	V _L (ON)	1	Pilot Input	—	8	12	mV _{rms}
		OFF	V _L (OFF)	1		3	6	—	
	Stereo LED Hysteresis	V _H	1	To LED turn off from LED turn on	—	2	—	mV _{rms}	
	Capture Range	C.R.	1	P = 20mV _{rms}	—	± 8	—	%	
	Signal To Noise Ratio	S/N	1	—	—	80	—	dB	

TEST CIRCUIT 1

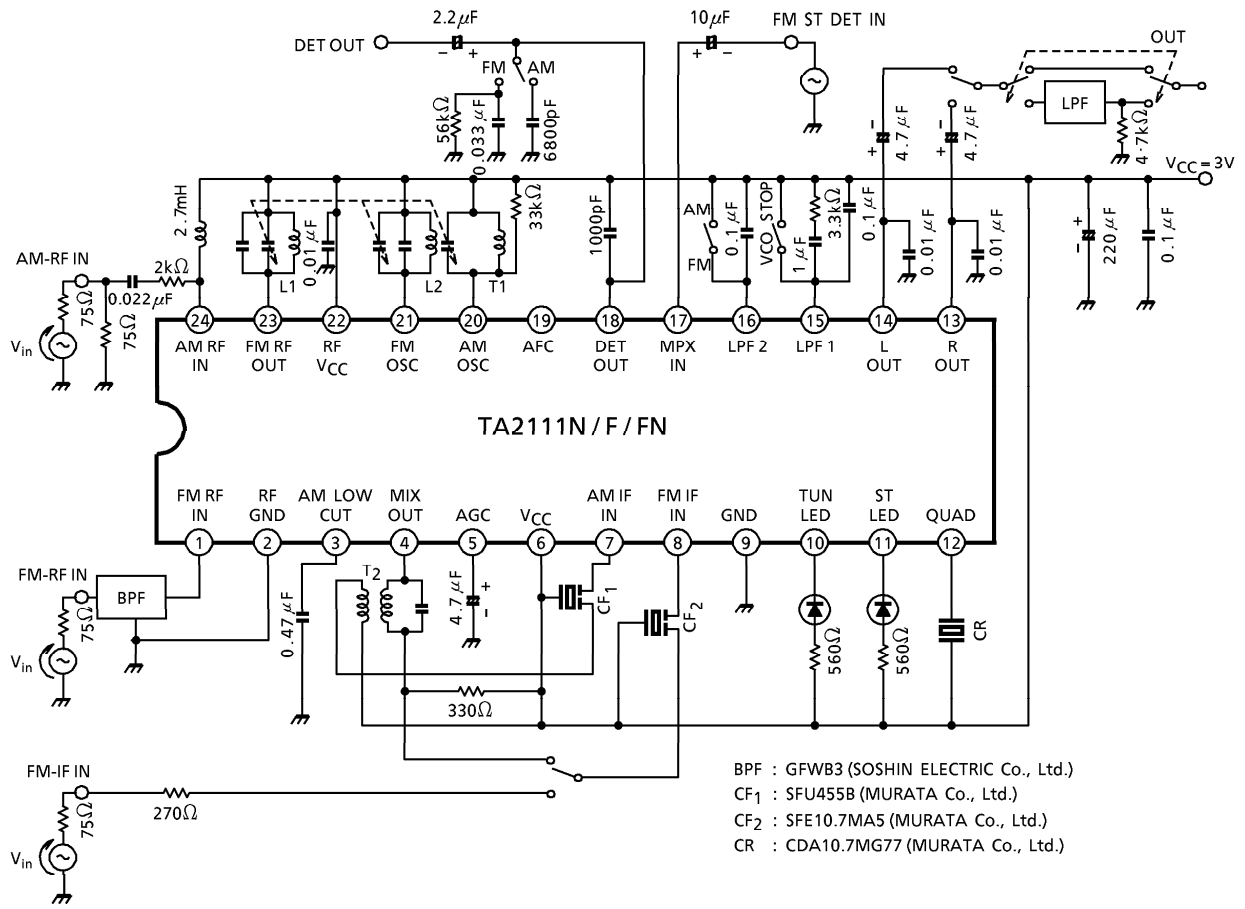

TEST CIRCUIT 2

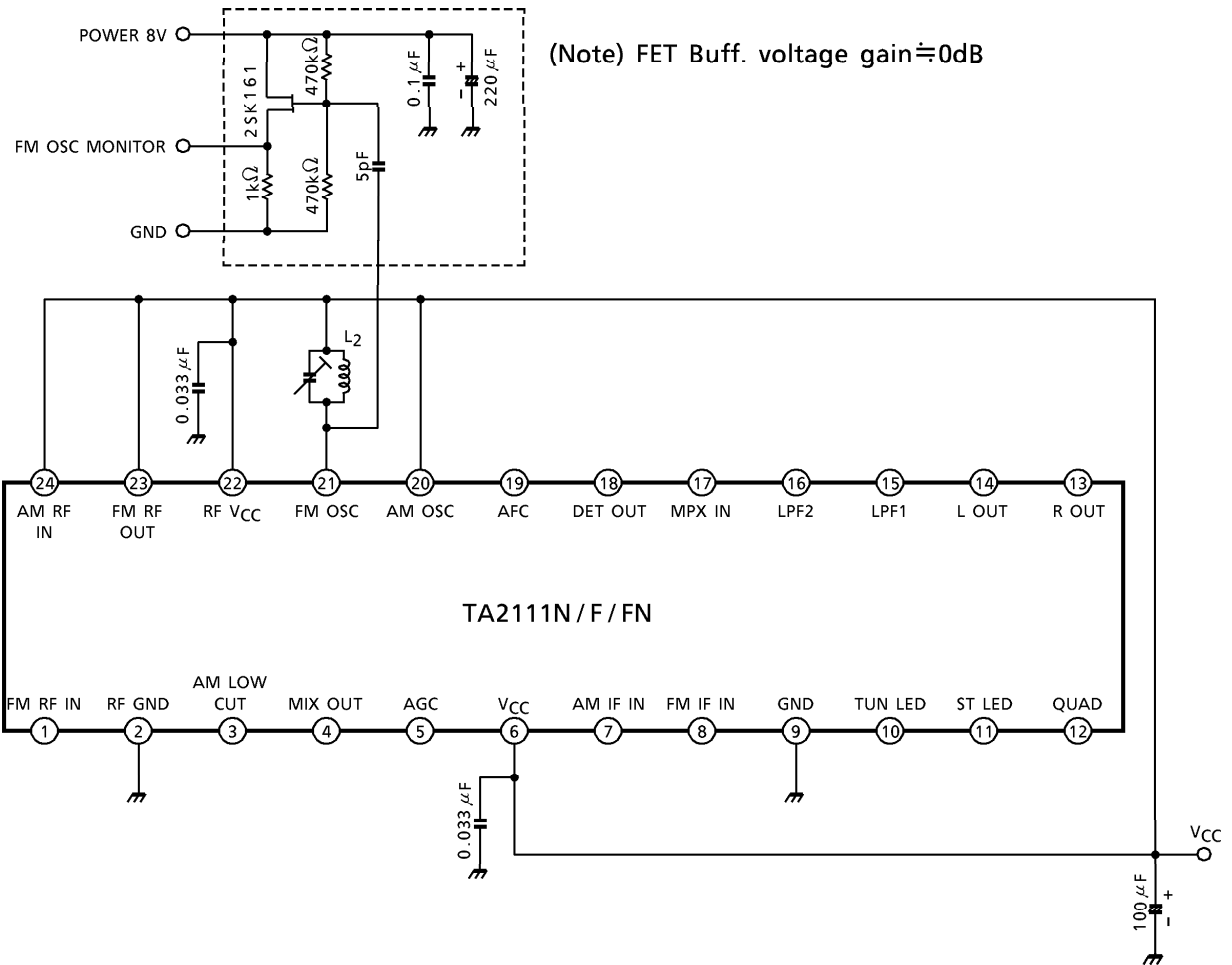

COIL DATA

COIL No.	TEST FREQ.	L (μ H)	Co (pF)	Q _o	TURNS					WIRE (mm ϕ)	REFERENCE
					1-2	2-3	1-3	1-4	4-6		
L ₁ FM RF	100MHz	—	—	79	—	—	—	2- $\frac{1}{2}$	—	0.16UEW	Ⓣ 666SNF-305NK
L ₂ FM OSC	100MHz	—	—	79	—	—	—	2	—	0.16UEW	Ⓣ 666SNF-306NK
T ₁ AM OSC	796kHz	268	—	65	19	95	—	—	—	0.05UEW	Ⓣ 5PNR-5146Y
T ₂ AM IFT	455kHz	—	470	60	—	—	109	—	7	0.05UEW	Ⓣ 5PLG-5147X

Ⓣ : TOKO Co., Ltd.

L₁ : FM RF

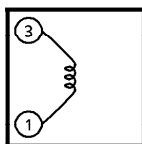

L₂ : FM OSC

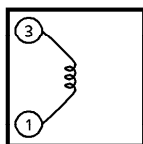

T₁ : AM OSC

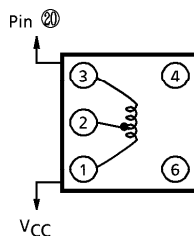

T₂ : AM IFT

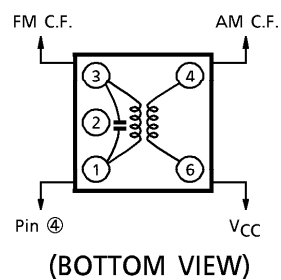

FM (F / E + IF)
VOD, V_{no}, THD, AMR - V_{in}

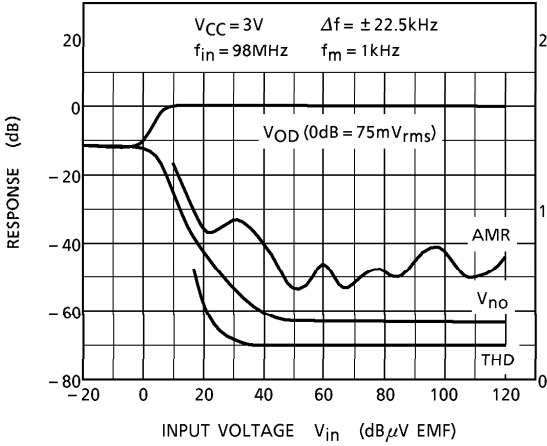

FM (IF)
VOD, V_{no}, THD - V_{in}

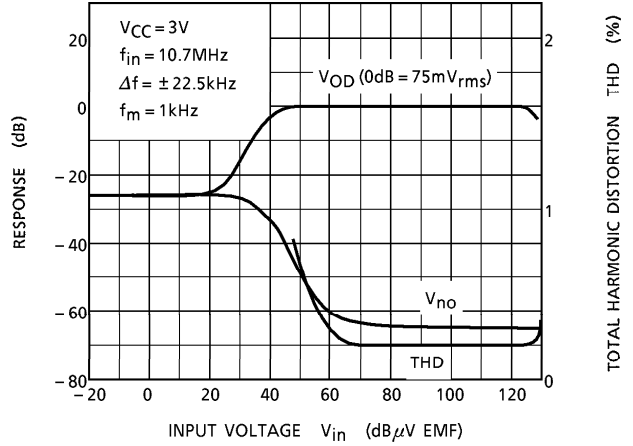

FM (IF)
VOD, THD - Δf

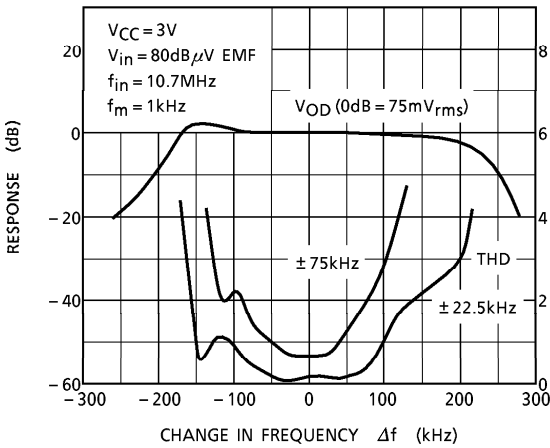

FM (IF)
VOD, V_{in}(lim) - V_{CC}

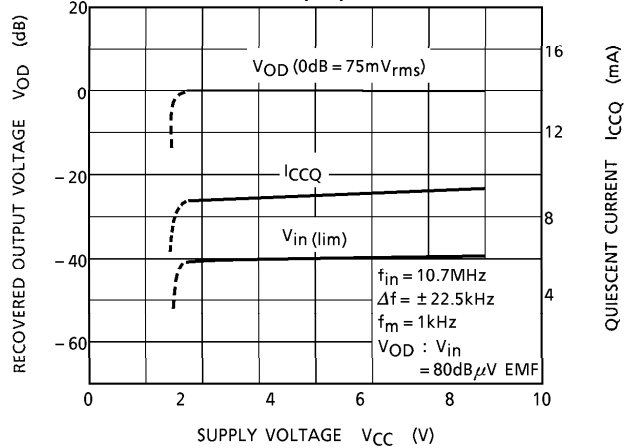

FM (IF)
VOD - T_a

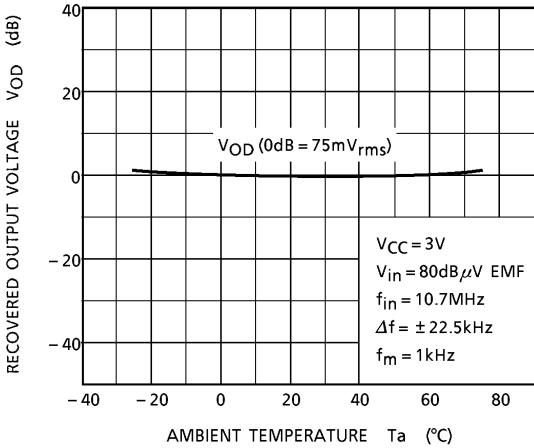

AM
VOD, V_{no}, THD - V_{in}

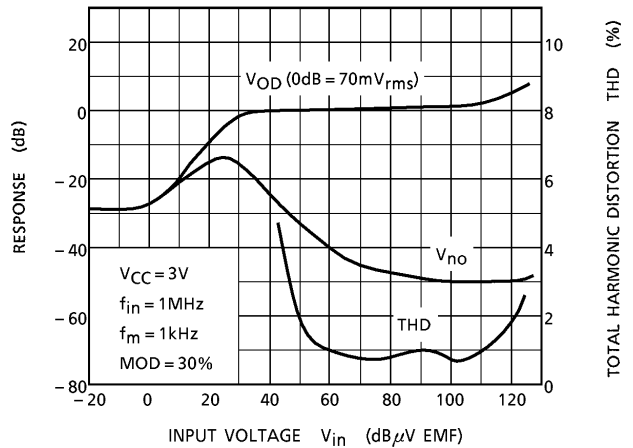

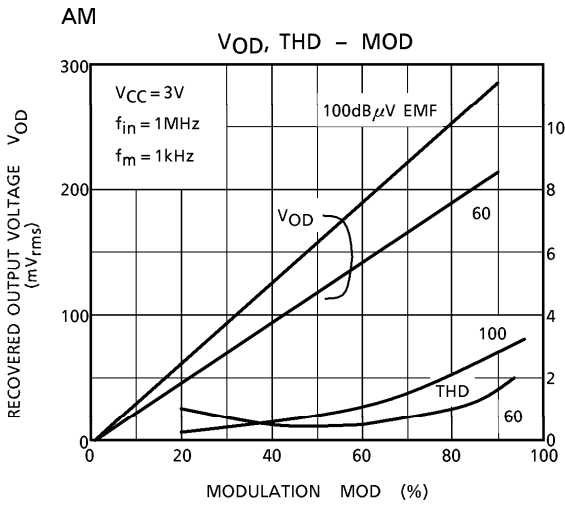

TOTAL HARMONIC DISTORTION THD (%)

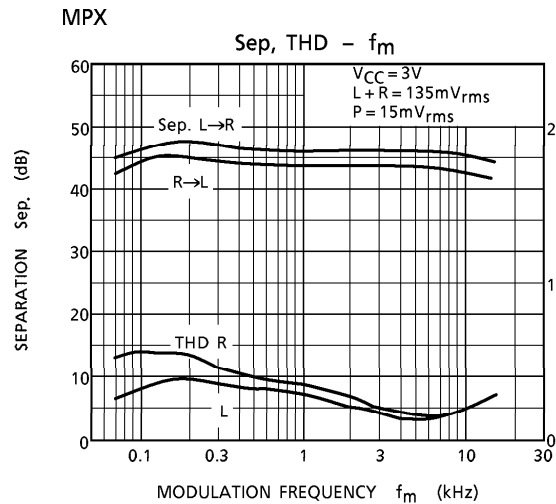
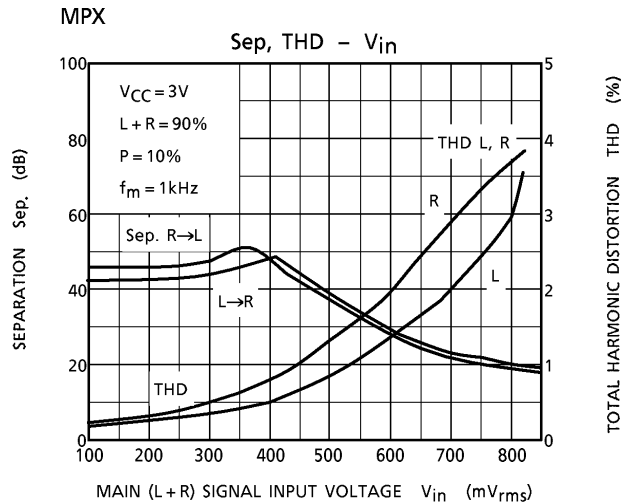
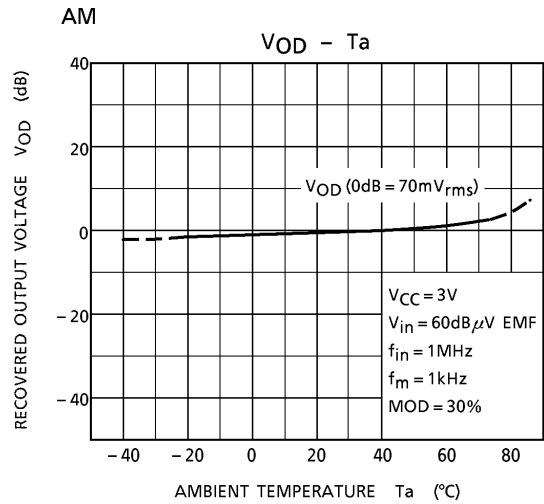
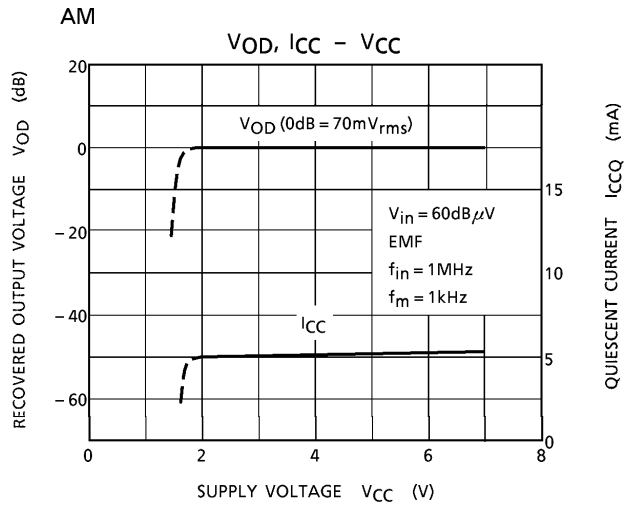

TOTAL HARMONIC DISTORTION THD (%)

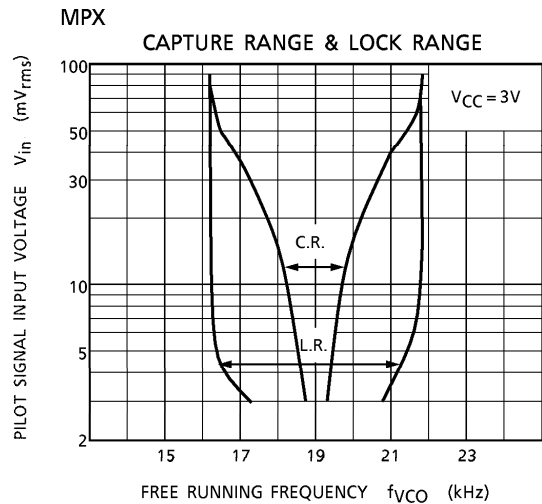

MPX

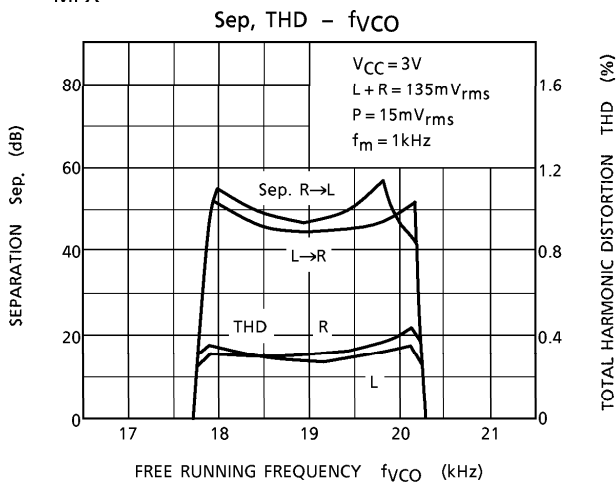

MPX

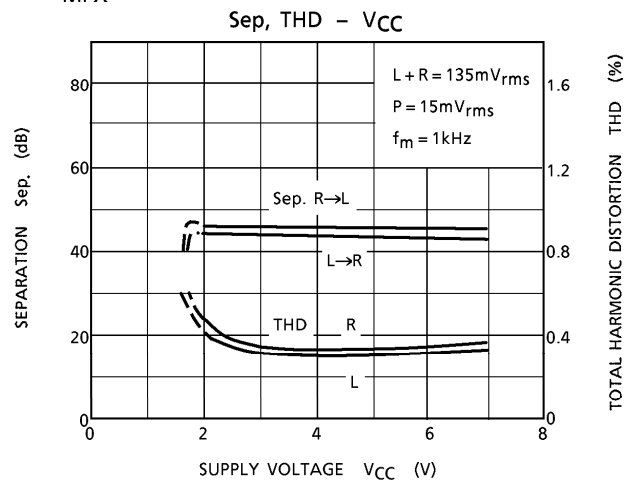

MPX

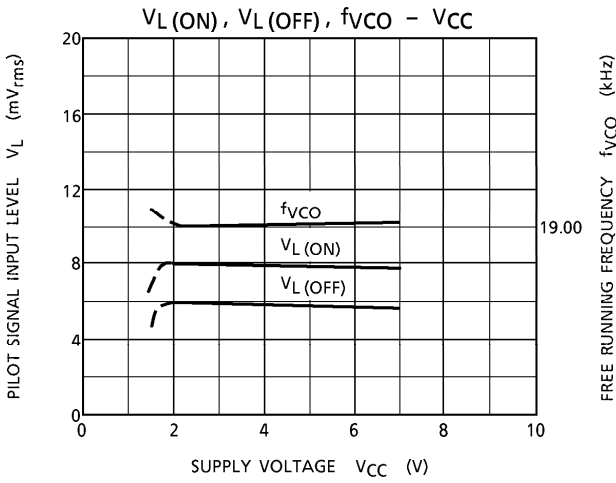

OUTLINE DRAWING
SDIP24-P-300-1.78

Unit : mm

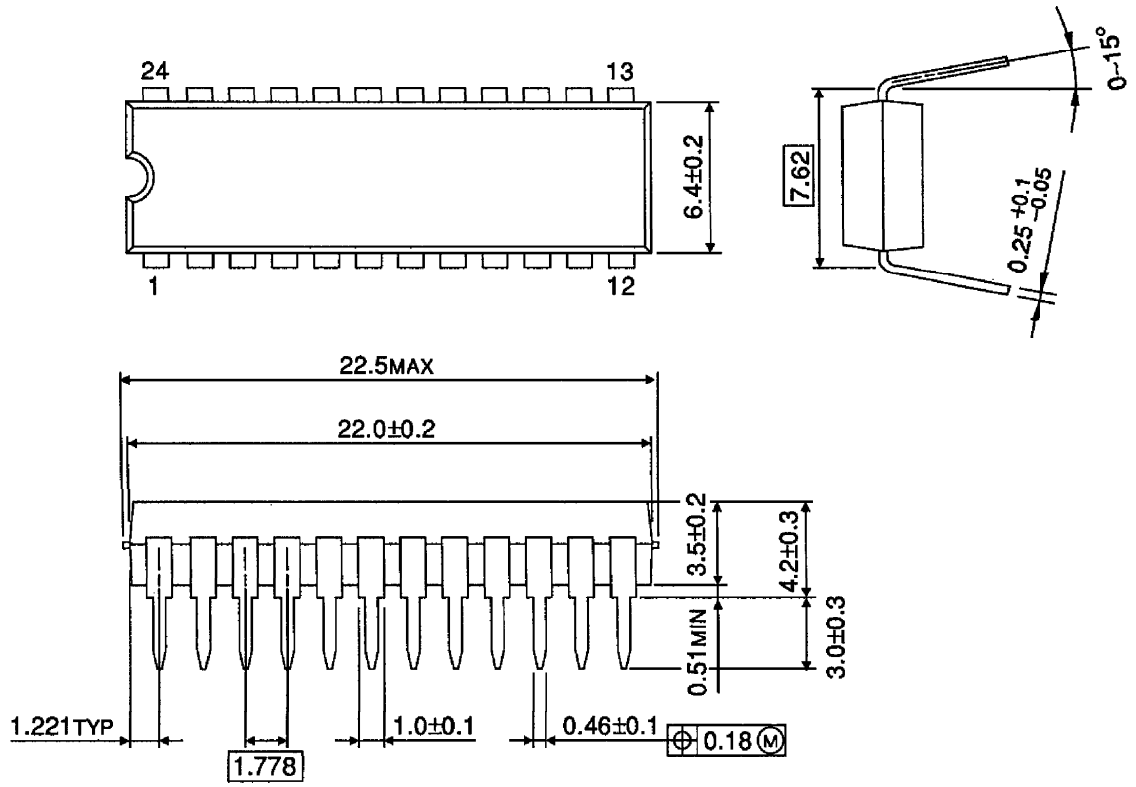

Weight : 1.2g (Typ.)

OUTLINE DRAWING
SSOP24-P-300-1.00

Unit : mm

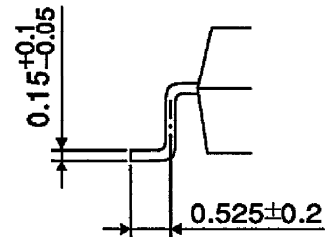
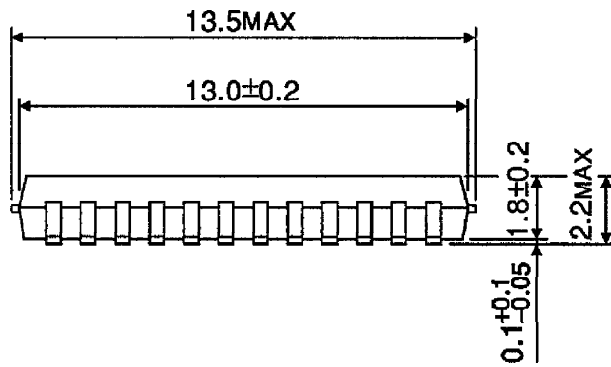
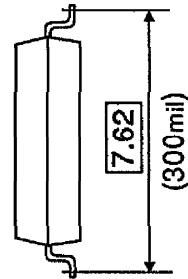
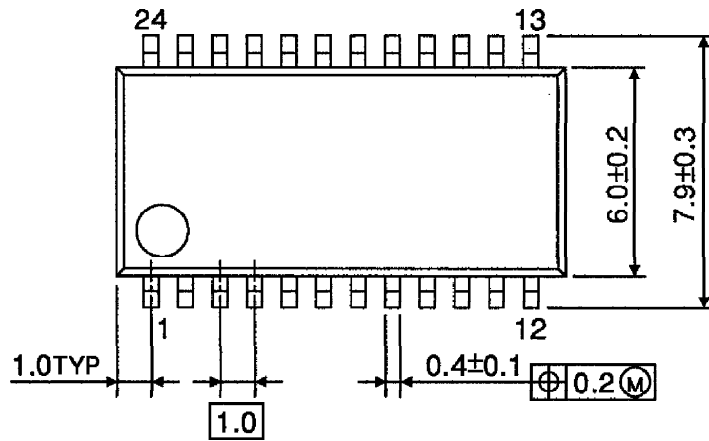

Weight : 0.31g (Typ.)

OUTLINE DRAWING
SSOP24-P-300-0.65A

Unit : mm

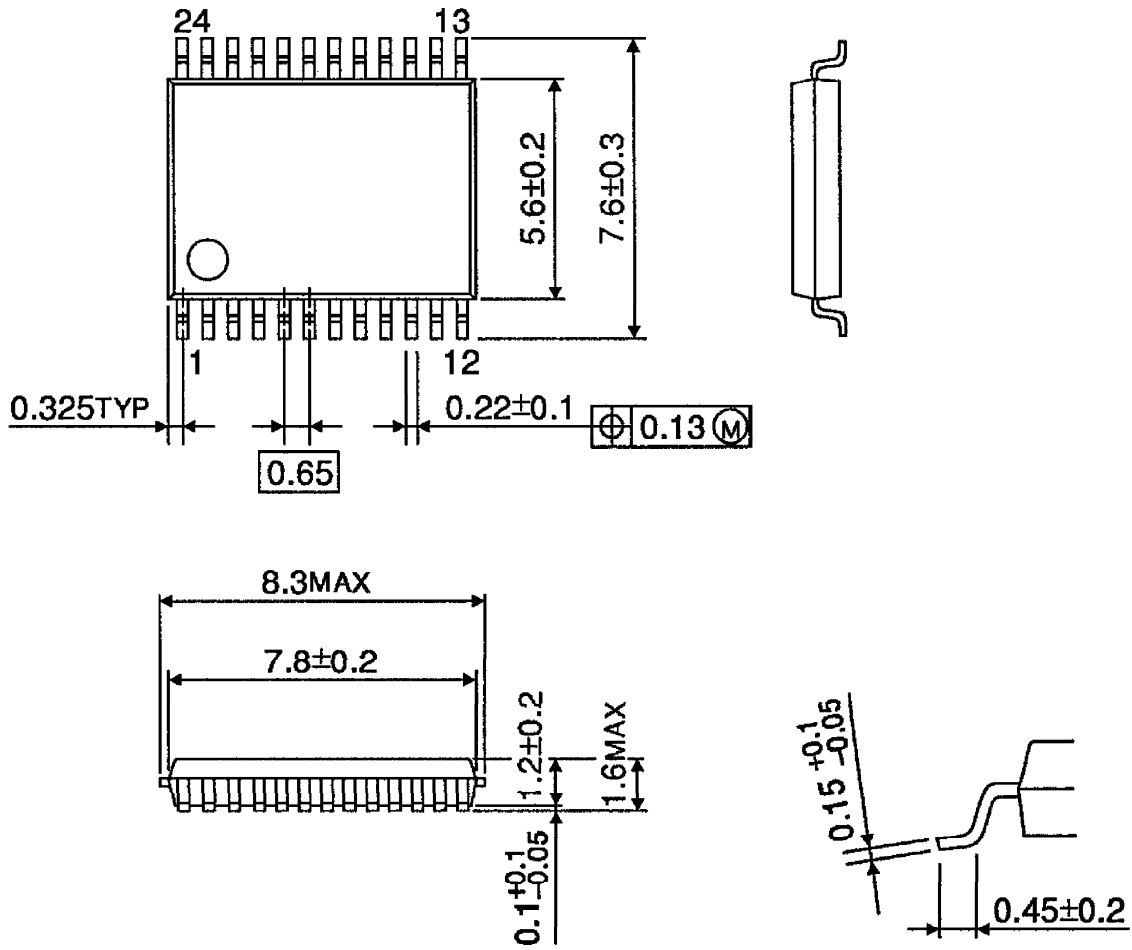

Weight : 0.14g (Typ.)