

## Programmable Timing Control Hub™ for Next Gen P4™ processor

### Recommended Application:

CK409 clock, Intel Yellow Cover part

### Output Features:

- 3 - 0.7V current-mode differential CPU pairs
- 1 - 0.7V current-mode differential SRC pair
- 7 - PCI (33MHz)
- 3 - PCICLK\_F, (33MHz) free-running
- 1 - USB, 48MHz
- 1 - DOT, 48MHz
- 2 - REF, 14.318MHz
- 4 - 3V66, 66.66MHz
- 1 - VCH/3V66, selectable 48MHz or 66MHz

### Key Specifications:

- CPU/SRC outputs cycle-cycle jitter < 125ps
- 3V66 outputs cycle-cycle jitter < 250ps
- PCI outputs cycle-cycle jitter < 250ps
- CPU outputs skew: < 100ps
- +/- 300ppm frequency accuracy on CPU & SRC clocks

### Functionality

B6b5	FS_A	FS_B	CPU MHz	SRC MHz	3V66 MHz	PCI MHz	REF MHz	USB/DOT MHz
0	0	0	100	100/200	66.66	33.33	14.318	48.00
	0	MID	Ref/N <sub>0</sub>	Ref/N <sub>1</sub>	Ref/N <sub>2</sub>	Ref/N <sub>3</sub>	Ref/N <sub>4</sub>	Ref/N <sub>5</sub>
	0	1	200	100/200	66.66	33.33	14.318	48.00
	1	0	133	100/200	66.66	33.33	14.318	48.00
	1	1	166	100/200	66.66	33.33	14.318	48.00
1	1	MID	Hi-Z	Hi-Z	Hi-Z	Hi-Z	Hi-Z	Hi-Z
	0	0	200	100/200	66.66	33.33	14.318	48.00
	0	1	400	100/200	66.66	33.33	14.318	48.00
	1	0	266	100/200	66.66	33.33	14.318	48.00
	1	1	333	100/200	66.66	33.33	14.318	48.00

### Features/Benefits:

- Supports tight ppm accuracy clocks for Serial-ATA.
- Supports spread spectrum modulation, 0 to -0.5% down spread.
- Supports CPU clks up to 400MHz in test mode.
- Uses external 14.318MHz crystal, external crystal load caps are required for frequency tuning.
- Supports undriven differential CPU, SRC pair in PD# and CPU\_STOP# for power management.

### Pin Configuration

REF0	1	56	FS_B
REF1	2	55	VDDA
VDDREF	3	54	GNDA
X1	4	53	GND
X2	5	52	IREF
GND	6	51	FS_A
PCICLK_F0	7	50	CPU_STOP#
PCICLK_F1	8	49	PCI_STOP#
PCICLK_F2	9	48	VDDCPU
VDDPCI	10	47	CPUCLKT2
GND	11	46	CPUCLKC2
PCICLK0	12	45	GND
PCICLK1	13	44	CPUCLKT1
PCICLK2	14	43	CPUCLKC1
PCICLK3	15	42	VDDCPU
VDDPCI	16	41	CPUCLKT0
GND	17	40	CPUCLKC0
PCICLK4	18	39	GND
PCICLK5	19	38	SRCCLKT
PCICLK6	20	37	SRCCLKC
PD#	21	36	VDD
3V66_0	22	35	Vtt_PWRGD#
3V66_1	23	34	VDD48
VDD3V66	24	33	GND
GND	25	32	48MHz_DOT
3V66_2	26	31	48MHz_USB
3V66_3	27	30	SDATA
SCLK	28	29	3V66_4/VCH

ICS952601

56-pin SSOP & TSSOP

**Pin Description**

<b>PIN #</b>	<b>PIN NAME</b>	<b>PIN TYPE</b>	<b>DESCRIPTION</b>
1	REF0	OUT	14.318 MHz reference clock.
2	REF1	OUT	14.318 MHz reference clock.
3	VDDREF	PWR	Ref, XTAL power supply, nominal 3.3V
4	X1	IN	Crystal input, Nominally 14.318MHz.
5	X2	OUT	Crystal output, Nominally 14.318MHz
6	GND	PWR	Ground pin.
7	PCICLK_F0	OUT	Free running PCI clock not affected by PCI_STOP# .
8	PCICLK_F1	OUT	Free running PCI clock not affected by PCI_STOP# .
9	PCICLK_F2	OUT	Free running PCI clock not affected by PCI_STOP# .
10	VDDPCI	PWR	Power supply for PCI clocks, nominal 3.3V
11	GND	PWR	Ground pin.
12	PCICLK0	OUT	PCI clock output.
13	PCICLK1	OUT	PCI clock output.
14	PCICLK2	OUT	PCI clock output.
15	PCICLK3	OUT	PCI clock output.
16	VDDPCI	PWR	Power supply for PCI clocks, nominal 3.3V
17	GND	PWR	Ground pin.
18	PCICLK4	OUT	PCI clock output.
19	PCICLK5	OUT	PCI clock output.
20	PCICLK6	OUT	PCI clock output.
21	PD#	IN	Asynchronous active low input pin used to power down the device into a low power state. The internal clocks are disabled and the VCO and the crystal are stopped. The latency of the power down will not be greater than 1.8ms. Internal pull-up of 150K nominal.
22	3V66_0	OUT	3.3V 66.66MHz clock output
23	3V66_1	OUT	3.3V 66.66MHz clock output
24	VDD3V66	PWR	Power pin for the 3V66 clocks.
25	GND	PWR	Ground pin.
26	3V66_2	OUT	3.3V 66.66MHz clock output
27	3V66_3	OUT	3.3V 66.66MHz clock output
28	SCLK	IN	Clock pin of SMBus circuitry, 5V tolerant.

Pin Description (Continued)

PIN #	PIN NAME	PIN TYPE	DESCRIPTION
29	3V66_4/VCH	OUT	66.66MHz clock output for AGP support. AGP-PCI should be aligned with a skew window tolerance of 500ps. VCH is 48MHz clock output for video controller hub.
30	SDATA	I/O	Data pin for SMBus circuitry, 5V tolerant.
31	48MHz_USB	OUT	48MHz clock output.
32	48MHz_DOT	OUT	48MHz clock output.
33	GND	PWR	Ground pin.
34	VDD48	PWR	Power pin for the 48MHz output.3.3V
35	Vtt_PWRGD#	IN	This 3.3V LVTTTL input is a level sensitive strobe used to determine when latch inputs are valid and are ready to be sampled. This is an active low input.
36	VDD	PWR	Power supply for SRC clocks, nominal 3.3V
37	SRCCLKC	OUT	Complement clock of differential pair for S-ATA support. +/- 300ppm accuracy required.
38	SRCCLKT	OUT	True clock of differential pair for S-ATA support. +/- 300ppm accuracy required.
39	GND	PWR	Ground pin.
40	CPUCLKC0	OUT	Complimentary clock of differential pair CPU outputs. These are current mode outputs. External resistors are required for voltage bias.
41	CPUCLKT0	OUT	True clock of differential pair CPU outputs. These are current mode outputs. External resistors are required for voltage bias.
42	VDDCPU	PWR	Supply for CPU clocks, 3.3V nominal
43	CPUCLKC1	OUT	Complimentary clock of differential pair CPU outputs. These are current mode outputs. External resistors are required for voltage bias.
44	CPUCLKT1	OUT	True clock of differential pair CPU outputs. These are current mode outputs. External resistors are required for voltage bias.
45	GND	PWR	Ground pin.
46	CPUCLKC2	OUT	Complimentary clock of differential pair CPU outputs. These are current mode outputs. External resistors are required for voltage bias.
47	CPUCLKT2	OUT	True clock of differential pair CPU outputs. These are current mode outputs. External resistors are required for voltage bias.
48	VDDCPU	PWR	Supply for CPU clocks, 3.3V nominal
49	PCI_STOP#	IN	Stops all PCICLKs and SRC pair besides the PCICLK_F clocks at logic 0 level, when input low. PCI and SRC clocks can be set to Free_Running through I2C. Internal pull-up of 150K nominal.
50	CPU_STOP#	IN	Stops all CPUCLK besides the free running clocks. Internal pull-up of 150K nominal
51	FS_A	IN	Frequency select pin, see Frequency table for functionality
52	IREF	OUT	This pin establishes the reference current for the differential current-mode output pairs. This pin requires a fixed precision resistor tied to ground in order to establish the appropriate current. 475 ohms is the standard value.
53	GND	PWR	Ground pin.
54	GND	PWR	Ground pin for core.
55	VDDA	PWR	3.3V power for the PLL core.
56	FS_B	IN	Frequency select pin, see Frequency table for functionality

**General Description**

ICS952601 follows Intel CK409 Yellow Cover specification. This clock synthesizer provides a single chip solution for next generation P4 Intel processors and Intel chipsets. ICS952601 is driven with a 14.318MHz crystal. It generates CPU outputs up to 200MHz. It also provides a tight ppm accuracy output for Serial ATA support.

**Block Diagram**

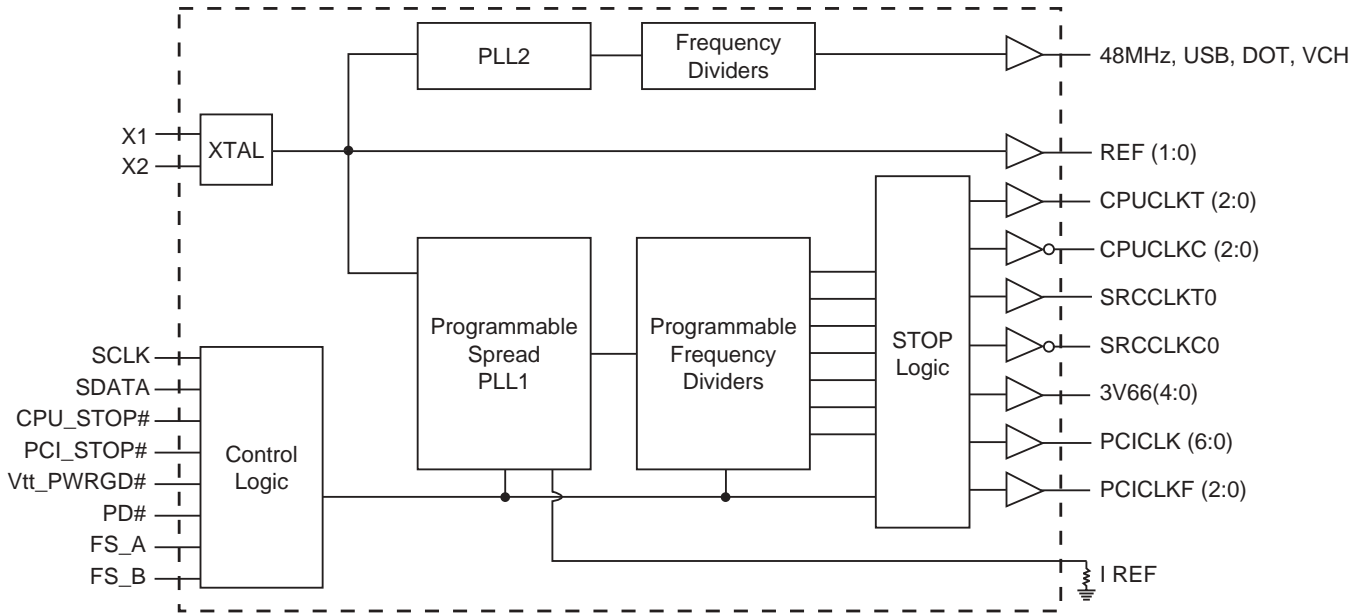

**Power Groups**

Pin Number		Description
VDD	GND	
3	6	Xtal, Ref
24	25	3V66 [0:3]
10,16	11,17	PCICLK outputs
36	39	SRCCLK outputs
55	54	Master clock, CPU Analog
34	33	48MHz, PLL, SCLK, SDATA
N/A	53	IREF
48, 42	45	CPUCLK clocks

**Absolute Max**

Symbol	Parameter	Min	Max	Units
VDD_A	3.3V Core Supply Voltage		$V_{DD} + 0.5V$	V
VDD_In	3.3V Logic Input Supply Voltage	GND - 0.5	$V_{DD} + 0.5V$	V
Ts	Storage Temperature	-65	150	°C
Tambient	Ambient Operating Temp	0	70	°C
Tcase	Case Temperature		115	°C
ESD prot	Input ESD protection human body model	2000		V

**Electrical Characteristics - Input/Supply/Common Output Parameters**
 $T_A = 0 - 70^\circ\text{C}$ ; Supply Voltage  $V_{DD} = 3.3\text{ V} \pm 5\%$ 

PARAMETER	SYMBOL	CONDITIONS	MIN	TYP	MAX	UNITS	NOTES
Input High Voltage	$V_{IH}$	3.3 V +/-5%	2		$V_{DD} + 0.3$	V	
Input MID Voltage	$V_{MID}$	3.3 V +/-5%	1		1.8	V	
Input Low Voltage	$V_{IL}$	3.3 V +/-5%	$V_{SS} - 0.3$		0.8	V	
Input High Current	$I_{IH}$	$V_{IN} = V_{DD}$	-5		5	uA	
Input Low Current	$I_{IL1}$	$V_{IN} = 0\text{ V}$ ; Inputs with no pull-up resistors	-5			uA	
	$I_{IL2}$	$V_{IN} = 0\text{ V}$ ; Inputs with pull-up resistors	-200			uA	
Operating Supply Current	$I_{DD3.3OP}$	Full Active, $C_L = \text{Full load}$ ;		258	350	mA	
Powerdown Current	$I_{DD3.3PD}$	all diff pairs driven		29	35	mA	
		all differential pairs tri-stated		0.3	12	mA	
Input Frequency <sup>3</sup>	$F_I$	$V_{DD} = 3.3\text{ V}$		14.31818		MHz	3
Pin Inductance <sup>1</sup>	$L_{pin}$				7	nH	1
Input Capacitance <sup>1</sup>	$C_{IN}$	Logic Inputs			5	pF	1
	$C_{OUT}$	Output pin capacitance			6	pF	1
	$C_{INX}$	X1 & X2 pins			5	pF	1
Clk Stabilization <sup>1,2</sup>	$T_{STAB}$	From $V_{DD}$ Power-Up or de-assertion of PD# to 1st clock			1.8	ms	1,2
Modulation Frequency		Triangular Modulation	30		33	kHz	1
Tdrive_SRC		SRC output enable after PCI_Stop# de-assertion			15	ns	1
Tdrive_PD#		CPU output enable after PD# de-assertion			300	us	1
Tfall_Pd#		PD# fall time of			5	ns	1
Trise_Pd#		PD# rise time of			5	ns	2
Tdrive_CPU_Stop#		CPU output enable after CPU_Stop# de-assertion			10	us	1
Tfall_CPU_Stop#		PD# fall time of			5	ns	1
Trise_CPU_Stop#		PD# rise time of			5	ns	2
SMBus Voltage	$V_{DD}$		2.7		5.5	V	1
Low-level Output Voltage	$V_{OL}$	@ $I_{PULLUP}$			0.4	V	1
Current sinking at $V_{OL} = 0.4\text{ V}$	$I_{PULLUP}$		4			mA	1
SCLK/SDATA Clock/Data Rise Time <sup>3</sup>	$T_{RI2C}$	(Max $V_{IL} - 0.15$ ) to (Min $V_{IH} + 0.15$ )			1000	ns	1
SCLK/SDATA Clock/Data Fall Time <sup>3</sup>	$T_{FI2C}$	(Min $V_{IH} + 0.15$ ) to (Max $V_{IL} - 0.15$ )			300	ns	1

<sup>1</sup>Guaranteed by design, not 100% tested in production.

<sup>2</sup>See timing diagrams for timing requirements.

<sup>3</sup>Input frequency should be measured at the REF output pin and tuned to ideal 14.31818MHz to meet ppm frequency accuracy on PLL outputs.

**Electrical Characteristics - CPU & SRC 0.7V Current Mode Differential Pair**

$T_A = 0 - 70^\circ\text{C}$ ;  $V_{DD} = 3.3\text{ V} \pm 5\%$ ;  $C_L = 2\text{pF}$

PARAMETER	SYMBOL	CONDITIONS	MIN	TYP	MAX	UNITS	NOTES
Current Source Output Impedance	$Z_o^1$	$V_o = V_x$	3000				1
Voltage High	VHigh	Statistical measurement on single ended signal using oscilloscope math function.	660	770	850	mV	1
Voltage Low	VLow		-150	5	150		1
Max Voltage	Vovs	Measurement on single ended signal using absolute value.		756	1150	mV	1
Min Voltage	Vuds		-300	-7			1
Crossing Voltage (abs)	Vcross(abs)		250	350	550	mV	1
Crossing Voltage (var)	d-Vcross	Variation of crossing over all edges		12	140	mV	1
Long Accuracy	ppm	see Tperiod min-max values	-300		300	ppm	1,2
Average period	Tperiod	200MHz nominal	4.9985	5.0000	5.0015	ns	2
		200MHz spread	4.9985		5.0266	ns	2
		166.66MHz nominal	5.9982	6.0000	6.0018	ns	2
		166.66MHz spread	5.9982		6.0320	ns	2
		133.33MHz nominal	7.4978	7.5000	7.5023	ns	2
		133.33MHz spread	7.4978		5.4000	ns	2
		100.00MHz nominal	9.9970	10.0000	10.0030	ns	2
		100.00MHz spread	9.9970		10.0533	ns	2
Absolute min period	$T_{absmin}$	200MHz nominal	4.8735			ns	1,2
		166.66MHz nominal/spread	5.8732			ns	1,2
		133.33MHz nominal/spread	7.3728			ns	1,2
		100.00MHz nominal/spread	9.8720			ns	1,2
Rise Time	$t_r$	$V_{OL} = 0.175\text{V}$ , $V_{OH} = 0.525\text{V}$	175	332	700	ps	1
Fall Time	$t_f$	$V_{OH} = 0.525\text{V}$ $V_{OL} = 0.175\text{V}$	175	344	700	ps	1
Rise Time Variation	d- $t_r$			30	125	ps	1
Fall Time Variation	d- $t_f$			30	125	ps	1
Duty Cycle	$d_{13}$	Measurement from differential waveform	45	49	55	%	1
Skew	$t_{sk3}$	$V_T = 50\%$		8	100	ps	1
Jitter, Cycle to cycle	$t_{j\text{cyc-cyc}}$	Measurement from differential waveform		37	125	ps	1

<sup>1</sup>Guaranteed by design, not 100% tested in production.

<sup>2</sup> All Long Term Accuracy and Clock Period specifications are guaranteed with the assumption that Ref output is at 14.31818MHz

**SRC clock outputs run at only 100MHz or 200MHz, specs for 133.33 and 166.66 do not apply to SRC clock pair.**

**Electrical Characteristics - 3V66 Mode: 3V66 [4:0]**
 $T_A = 0 - 70^\circ\text{C}$ ;  $V_{DD} = 3.3\text{ V} \pm 5\%$ ;  $C_L = 10\text{-}30\text{ pF}$  (unless otherwise specified)

PARAMETER	SYMBOL	CONDITIONS	MIN	TYP	MAX	UNITS	Notes
Long Accuracy	ppm	see Tperiod min-max values	-300		300	ppm	1,2
Clock period	$T_{\text{period}}$	66.66MHz output nominal	14.9955	15	15.0045	ns	2
		66.66MHz output spread	14.9955		15.0799	ns	2
Output High Voltage	$V_{OH}$	$I_{OH} = -1\text{ mA}$	2.4			V	
Output Low Voltage	$V_{OL}$	$I_{OL} = 1\text{ mA}$			0.55	V	
Output High Current	$I_{OH}$	$V_{OH} @ \text{MIN} = 1.0\text{ V}$	-33			mA	
		$V_{OH} @ \text{MAX} = 3.135\text{ V}$			-33	mA	
Output Low Current	$I_{OL}$	$V_{OL} @ \text{MIN} = 1.95\text{ V}$	30			mA	
		$V_{OL} @ \text{MAX} = 0.4\text{ V}$			38	mA	
Edge Rate		Rising edge rate	1		4	V/ns	1
Edge Rate		Falling edge rate	1		4	V/ns	1
Rise Time	$t_{r1}$	$V_{OL} = 0.4\text{ V}, V_{OH} = 2.4\text{ V}$	0.5	1.92	2	ns	1
Fall Time	$t_{f1}$	$V_{OH} = 2.4\text{ V}, V_{OL} = 0.4\text{ V}$	0.5	1.97	2	ns	1
Duty Cycle	$d_{t1}$	$V_T = 1.5\text{ V}$	45	53.1	55	%	1
Skew	$t_{sk1}$	$V_T = 1.5\text{ V}$		38	250	ps	1
Jitter	$t_{j\text{cyc-cyc}}$	$V_T = 1.5\text{ V}$ 3V66		139	250	ps	1

<sup>1</sup>Guaranteed by design, not 100% tested in production.

<sup>2</sup>All Long Term Accuracy and Clock Period specifications are guaranteed with the assumption that Ref output is at 14.31818MHz

**Electrical Characteristics - PCICLK/PCICLK\_F**
 $T_A = 0 - 70^\circ\text{C}$ ;  $V_{DD} = 3.3\text{ V} \pm 5\%$ ;  $C_L = 10\text{-}30\text{ pF}$  (unless otherwise specified)

PARAMETER	SYMBOL	CONDITIONS	MIN	TYP	MAX	UNITS	Notes
Long Accuracy	ppm	see Tperiod min-max values	-300		300	ppm	1,2
Clock period	$T_{\text{period}}$	33.33MHz output nominal	29.9910	30	30.0090	ns	2
		33.33MHz output spread	29.9910		30.1598	ns	2
Output High Voltage	$V_{OH}$	$I_{OH} = -1\text{ mA}$	2.4			V	
Output Low Voltage	$V_{OL}$	$I_{OL} = 1\text{ mA}$			0.55	V	
Output High Current	$I_{OH}$	$V_{OH} @ \text{MIN} = 1.0\text{ V}$	-33			mA	
		$V_{OH} @ \text{MAX} = 3.135\text{ V}$			-33	mA	
Output Low Current	$I_{OL}$	$V_{OL} @ \text{MIN} = 1.95\text{ V}$	30			mA	
		$V_{OL} @ \text{MAX} = 0.4\text{ V}$			38	mA	
Edge Rate		Rising edge rate	1		4	V/ns	1
Edge Rate		Falling edge rate	1		4	V/ns	1
Rise Time	$t_{r1}$	$V_{OL} = 0.4\text{ V}, V_{OH} = 2.4\text{ V}$	0.5	1.92	2	ns	1
Fall Time	$t_{f1}$	$V_{OH} = 2.4\text{ V}, V_{OL} = 0.4\text{ V}$	0.5	1.9	2	ns	1
Duty Cycle	$d_{t1}$	$V_T = 1.5\text{ V}$	45	51.4	55	%	1
Skew	$t_{sk1}$	$V_T = 1.5\text{ V}$		18	500	ps	1
Jitter	$t_{j\text{cyc-cyc}}$	$V_T = 1.5\text{ V}$ 3V66		92	250	ps	1

<sup>1</sup>Guaranteed by design, not 100% tested in production.

<sup>2</sup>All Long Term Accuracy and Clock Period specifications are guaranteed with the assumption that Ref output is at 14.31818MHz

**Electrical Characteristics - 48MHz DOT Clock**
 $T_A = 0 - 70^\circ\text{C}$ ;  $V_{DD} = 3.3\text{ V} \pm 5\%$ ;  $C_L = 5\text{-}10\text{ pF}$  (unless otherwise specified)

PARAMETER	SYMBOL	CONDITIONS	MIN	TYP	MAX	UNITS	Notes
Long Accuracy	ppm	see Tperiod min-max values	-200		200	ppm	1,2
Clock period	$T_{\text{period}}$	66.66MHz output nominal	20.8257		20.8340	ns	2
Output High Voltage	$V_{OH}$	$I_{OH} = -1\text{ mA}$	2.4			V	
Output Low Voltage	$V_{OL}$	$I_{OL} = 1\text{ mA}$			0.55	V	
Output High Current	$I_{OH}$	$V_{OH} @ \text{MIN} = 1.0\text{ V}$	-33			mA	
		$V_{OH} @ \text{MAX} = 3.135\text{ V}$			-33	mA	
Output Low Current	$I_{OL}$	$V_{OL} @ \text{MIN} = 1.95\text{ V}$	30			mA	
		$V_{OL} @ \text{MAX} = 0.4\text{ V}$			38	mA	
Edge Rate		Rising edge rate	2		4	V/ns	1
Edge Rate		Falling edge rate	2		4	V/ns	1
Rise Time	$t_{r1}$	$V_{OL} = 0.4\text{ V}$ , $V_{OH} = 2.4\text{ V}$	0.5	0.71	1	ns	1
Fall Time	$t_{f1}$	$V_{OH} = 2.4\text{ V}$ , $V_{OL} = 0.4\text{ V}$	0.5	0.77	1	ns	1
Duty Cycle	$d_{t1}$	$V_T = 1.5\text{ V}$	45	49	55	%	1
Long Term Jitter		125us period jitter (8kHz frequency modulation amplitude)		0.7	2	ns	1

<sup>1</sup>Guaranteed by design, not 100% tested in production.

<sup>2</sup>All Long Term Accuracy and Clock Period specifications are guaranteed with the assumption that Ref output is at 14.31818MHz

**Electrical Characteristics - VCH, 48MHz, USB**
 $T_A = 0 - 70^\circ\text{C}$ ;  $V_{DD} = 3.3\text{ V} \pm 5\%$ ;  $C_L = 10\text{-}20\text{ pF}$  (unless otherwise specified)

PARAMETER	SYMBOL	CONDITIONS	MIN	TYP	MAX	UNITS	Notes
Long Accuracy	ppm	see Tperiod min-max values	-200		200	ppm	1,2
Clock period	$T_{\text{period}}$	66.66MHz output nominal	20.8257		20.8340	ns	2
Output High Voltage	$V_{OH}$	$I_{OH} = -1\text{ mA}$	2.4			V	
Output Low Voltage	$V_{OL}$	$I_{OL} = 1\text{ mA}$			0.55	V	
Output High Current	$I_{OH}$	$V_{OH} @ \text{MIN} = 1.0\text{ V}$	-33			mA	
		$V_{OH} @ \text{MAX} = 3.135\text{ V}$			-33	mA	
Output Low Current	$I_{OL}$	$V_{OL} @ \text{MIN} = 1.95\text{ V}$	30			mA	
		$V_{OL} @ \text{MAX} = 0.4\text{ V}$			38	mA	
Edge Rate		Rising edge rate	1		2	V/ns	1
Edge Rate		Falling edge rate	1		2	V/ns	1
Rise Time	$t_{r1}$	$V_{OL} = 0.4\text{ V}$ , $V_{OH} = 2.4\text{ V}$	1	1.43	2	ns	1
Fall Time	$t_{f1}$	$V_{OH} = 2.4\text{ V}$ , $V_{OL} = 0.4\text{ V}$	1	1.33	2	ns	1
Duty Cycle	$d_{t1}$	$V_T = 1.5\text{ V}$	45	48	55	%	1
Long Term Jitter		125us period jitter (8kHz frequency modulation amplitude)		0.7	6	ns	1

<sup>1</sup>Guaranteed by design, not 100% tested in production.

<sup>2</sup>All Long Term Accuracy and Clock Period specifications are guaranteed with the assumption that Ref output is at 14.31818MHz



### Electrical Characteristics - REF-14.318MHz

$T_A = 0 - 70^\circ\text{C}$ ;  $V_{DD} = 3.3\text{ V} \pm 5\%$ ;  $C_L = 10\text{-}20\text{ pF}$  (unless otherwise specified)

PARAMETER	SYMBOL	CONDITIONS	MIN	TYP	MAX	UNITS
Long Accuracy	ppm <sup>1</sup>	see Tperiod min-max values	-300		300	ppm
Clock period	T <sub>period</sub>	14.318MHz output nominal	69.8270		69.8550	ns
Output High Voltage	V <sub>OH</sub> <sup>1</sup>	I <sub>OH</sub> = -1 mA	2.4			V
Output Low Voltage	V <sub>OL</sub> <sup>1</sup>	I <sub>OL</sub> = 1 mA			0.4	V
Output High Current	I <sub>OH</sub> <sup>1</sup>	V <sub>OH</sub> @MIN = 1.0 V, V <sub>OH</sub> @MAX = 3.135 V	-29		-23	mA
Output Low Current	I <sub>OL</sub> <sup>1</sup>	V <sub>OL</sub> @MIN = 1.95 V, V <sub>OL</sub> @MAX = 0.4 V	29		27	mA
Rise Time	t <sub>r1</sub> <sup>1</sup>	V <sub>OL</sub> = 0.4 V, V <sub>OH</sub> = 2.4 V	1	1.92	2	ns
Fall Time	t <sub>f1</sub> <sup>1</sup>	V <sub>OH</sub> = 2.4 V, V <sub>OL</sub> = 0.4 V	1	1.92	2	ns
Skew	t <sub>sk1</sub> <sup>1</sup>	V <sub>T</sub> = 1.5 V		26	500	ps
Duty Cycle	d <sub>t1</sub> <sup>1</sup>	V <sub>T</sub> = 1.5 V	45	53.4	55	%
Jitter	t <sub>jvc-cvc</sub> <sup>1</sup>	V <sub>T</sub> = 1.5 V		284	1000	ps

<sup>1</sup>Guaranteed by design, not 100% tested in production.

### Group to Group Skews at Common Transition Edges

GROUP	SYMBOL	CONDITIONS	MIN	TYP	MAX	UNITS
200MHZ CPU to 3V66 <sup>1</sup>	S <sub>CPU200-3V66</sub>	3V66 (4:0) leads 200MHZ CPU	-2.1	-1.6	-1.1	ns
3V66 to PCI	S <sub>3V66-PCI</sub>	3V66 (4:0) leads 33MHz PCI	1.50	2.59	3.50	ns
DOT-USB	S <sub>DOT_USB</sub>	180 degrees out of phase	0.00		1.00	ns
DOT-VCH	S <sub>DOT_VCH</sub>	in phase	0.00		1.00	ns

1. 3V66 MHz C<sub>L</sub> = 0pf, R<sub>series</sub> = 33 ohm. CPU CL = 2 pf, R<sub>series</sub> = 33 ohm, R<sub>shunt</sub> = 49.9 ohms. Measured at the pins of the 952601.

## General I<sup>2</sup>C serial interface information for the ICS952601

### How to Write:

- Controller (host) sends a start bit.
- Controller (host) sends the write address  $D2_{(H)}$
- ICS clock will **acknowledge**
- Controller (host) sends the beginning byte location = N
- ICS clock will **acknowledge**
- Controller (host) sends the data byte count = X
- ICS clock will **acknowledge**
- Controller (host) starts sending **Byte N through Byte N + X - 1**  
(see Note 2)
- ICS clock will **acknowledge** each byte **one at a time**
- Controller (host) sends a Stop bit

### How to Read:

- Controller (host) will send start bit.
- Controller (host) sends the write address  $D2_{(H)}$
- ICS clock will **acknowledge**
- Controller (host) sends the beginning byte location = N
- ICS clock will **acknowledge**
- Controller (host) will send a separate start bit.
- Controller (host) sends the read address  $D3_{(H)}$
- ICS clock will **acknowledge**
- ICS clock will send the data byte count = X
- ICS clock sends **Byte N + X - 1**
- ICS clock sends **Byte 0 through byte X (if  $X_{(H)}$  was written to byte 8)**.
- Controller (host) will need to acknowledge each byte
- Controller (host) will send a not acknowledge bit
- Controller (host) will send a stop bit

Index Block Write Operation		
Controller (Host)		ICS (Slave/Receiver)
T	starT bit	
Slave Address $D2_{(H)}$		
WR	WRite	
		ACK
Beginning Byte = N		
		ACK
Data Byte Count = X		
		ACK
Beginning Byte N		X Byte
○		
○		
○		
Byte N + X - 1		
		ACK
P	stoP bit	

Index Block Read Operation		
Controller (Host)		ICS (Slave/Receiver)
T	starT bit	
Slave Address $D2_{(H)}$		
WR	WRite	
		ACK
Beginning Byte = N		
		ACK
RT	Repeat starT	
Slave Address $D3_{(H)}$		
RD	ReaD	
		ACK
		Data Byte Count = X
ACK		X Byte
ACK		
○		
○		
○		
		Beginning Byte N
		○
		○
		○
		Byte N + X - 1
N	Not acknowledge	
P	stoP bit	



I<sup>2</sup>C Table: Read-Back Register

Byte 0	Pin #	Name	Control Function	Type	0	1	PWD
Bit 7	-	RESERVED	RESERVED	-	RESERVED		X
Bit 6	-	RESERVED	RESERVED	-	RESERVED		X
Bit 5	-	RESERVED	RESERVED	-	RESERVED		X
Bit 4	-	RESERVED	RESERVED	-	RESERVED		X
Bit 3	-	PCI_STOP#	PCI STOP# Read Back	R	READBACK		X
Bit 2	-	CPU_STOP#	CPU STOP Read Back	R	READBACK		X
Bit 1	-	FSB	Freq Select 1 Read Back	R	READBACK of CPU(2:0) Frequency		X
Bit 0	-	FSA	Freq Select 0 Read Back	R			X

I<sup>2</sup>C Table: Spreading and Device Behavior Control Register

Byte 1	Pin #	Name	Control Function	Type	0	1	PWD
Bit 7	37,38	SRC/SRC#	SRC Free-Running Control	RW	FREE-RUN	STOPPABLE	0
Bit 6	37,38	SRC	Output Control	RW	Disable	Enable	1
Bit 5	46,47	CPUT2/CPUC2	CPU FREE-RUNNING CONTROL	RW	FREE-RUN	STOPPABLE	1
Bit 4	43,44	CPUT1/CPUC1		RW	FREE-RUN	STOPPABLE	1
Bit 3	40,41	CPUT0/CPUC0		RW	FREE-RUN	STOPPABLE	1
Bit 2	46,47	CPUT2/CPUC2	Output Control	RW	Disable	Enable	1
Bit 1	43,44	CPUT1/CPUC1	Output Control	RW	Disable	Enable	1
Bit 0	40,41	CPUT0/CPUC0	Output Enable	RW	Disable	Enable	1

I<sup>2</sup>C Table: Output Control Register

Byte 2	Pin #	Name	Control Function	Type	0	1	PWD
Bit 7	37,38	SRC_PD# Drive Mode	0: Driven in PD#	RW	Driven	Hi-Z	0
Bit 6	37,38	SRC_Stop# Drive Mode	0: Driven in PCI_Stop#	RW	Driven	Hi-Z	0
Bit 5	46,47	CPUT2_PD# Drive Mode	0:driven in PD# 1: Tri-stated	RW	Driven	Hi-Z	0
Bit 4	43,44	CPUT1_PD# Drive Mode		RW	Driven	Hi-Z	0
Bit 3	40,41	CPUT0_PD# Drive Mode		RW	Driven	Hi-Z	0
Bit 2	46,47	CPUT2_Stop Drive Mode	0:driven when stopped 1: Tri-stated	RW	Driven	Hi-Z	0
Bit 1	43,44	CPUT1_Stop Drive Mode		RW	Driven	Hi-Z	0
Bit 0	40,41	CPUT0_Stop Drive Mode		RW	Driven	Hi-Z	0



I<sup>2</sup>C Table: Output Control Register

Byte 3	Pin #	Name	Control Function	Type	0	1	PWD
Bit 7	7,8,9,12,13,14,15, 18,19,20,37,38,	PCI_Stop#	PCI_Stop# Control 0:all stoppable PCI and SRC are stopped	RW	Enable	Disable	1
Bit 6	20	PCICLK6	Output Control	RW	Disable	Enable	1
Bit 5	19	PCICLK5	Output Control	RW	Disable	Enable	1
Bit 4	18	PCICLK4	Output Control	RW	Disable	Enable	1
Bit 3	15	PCICLK3	Output Control	RW	Disable	Enable	1
Bit 2	14	PCICLK2	Output Control	RW	Disable	Enable	1
Bit 1	13	PCICLK1	Output Control	RW	Disable	Enable	1
Bit 0	12	PCICLK0	Output Control	RW	Disable	Enable	1

I<sup>2</sup>C Table: Output Control Register

Byte 4	Pin #	Name	Control Function	Type	0	1	PWD
Bit 7	31	48MHz_USB 2x output drive	0=2x drive	RW	2x drive	normal	0
Bit 6	31	48MHz_USB	Output Control	RW	Disable	Enable	1
Bit 5	9	PCIF2	PCI FREE-RUN NING CONTROL	RW	FREE-RUN	STOPPABLE	0
Bit 4	8	PCIF1		RW	FREE-RUN	STOPPABLE	0
Bit 3	7	PCIF0		RW	FREE-RUN	STOPPABLE	0
Bit 2	9	PCICLK_F2	Output Control	RW	Disable	Enable	1
Bit 1	8	PCICLK_F1	Output Control	RW	Disable	Enable	1
Bit 0	7	PCICLK_F0	Output Control	RW	Disable	Enable	1

I<sup>2</sup>C Table: Output Control Register

Byte 5	Pin #	Name	Control Function	Type	0	1	PWD
Bit 7	32	48MHZ_DOT	Output Control	RW	Disable	Enable	1
Bit 6	-	RESERVED	RESERVED	-	-	-	0
Bit 5	29	3V66_4/VCH Select	Output Select	RW	3V66	VCH	0
Bit 4	29	3V66_4/VCH	Output Control	RW	Disable	Enable	1
Bit 3	27	3V66_3	Output Control	RW	Disable	Enable	1
Bit 2	26	3V66_2	Output Control	RW	Disable	Enable	1
Bit 1	23	3V66_1	Output Control	RW	Disable	Enable	1
Bit 0	22	3V66_0	Output Control	RW	Disable	Enable	1



I<sup>2</sup>C Table: Output Control and Fix Frequency Register

Byte 6	Pin #	Name	Control Function	Type	0	1	PWD
Bit 7	1,2,7,8,9,12,13,14,15,18,19,20,22,23,26,27,29,31,32,37,38,40,41,43,44,46,47	Test Clock Mode	Test Clock Mode	-	Disable	Enable	0
Bit 6	-	RESERVED	-	-	-	-	0
Bit 5	40,41,43,44,46,47	RESERVED	FS_A and FS_B Operation	-	Normal	Test Mode	0
Bit 4	37,38	RESERVED	SRC Frequency Select	-	100MHz	200MHz	0
Bit 3	-	RESERVED	-	-	-	-	0
Bit 2	7,8,9,12,13,14,15,18,19,20,22,23,26,27,29,31,32,37,38,40,41,43,44,46,47	Spread Spectrum Mode			Spread OFF	Spread ON	0
Bit 1	2	REF1	Output Control	RW	Disable	Enable	1
Bit 0	1	REF0	Output Control	RW	Disable	Enable	1

I<sup>2</sup>C Table: Vendor & Revision ID Register

Byte 7	Pin #	Name	Control Function	Type	0	1	PWD
Bit 7	-	RID3	REVISION ID	R	-	-	X
Bit 6	-	RID2		R	-	-	X
Bit 5	-	RID1		R	-	-	X
Bit 4	-	RID0		R	-	-	X
Bit 3	-	VID3	VENDOR ID	R	-	-	0
Bit 2	-	VID2		R	-	-	0
Bit 1	-	VID1		R	-	-	0
Bit 0	-	VID0		R	-	-	1

### PCI Stop Functionality

The PCI\_STOP# signal is an active low input controlling PCI and SRC outputs. If PCIF (2:0) and SRC clocks can be set to be free-running through I2C programming. Outputs set to be free-running will ignore both the PCI\_STOP pin and the PCI\_STOP register bit.

PCI_STOP#	CPU	CPU #	SRC	SRC#	3V66	PCIF/PCI	USB/DOT	REF	Note
1	Normal	Normal	Normal	Normal	66MHz	33MHz	48MHz	14.318MHz	
0	Normal	Normal	Iref * 6 or Float	Low	66MHz	Low	48MHz	14.318MHz	

### PCI\_STOP# Assertion (transition from '1' to '0')

The clock samples the PCI\_STOP# signal on a rising edge of PCIF clock. After detecting the PCI\_STOP# assertion low, all PCI[6:0] and stoppable PCIF[2:0] clocks will latch low on their next high to low transition. After the PCI clocks are latched low, the SRC clock, (if set to stoppable) will latch high at Iref \* 6 (or tristate if Byte 2 Bit 6 = 1) upon its next low to high transition and the SRC# will latch low as shown below.

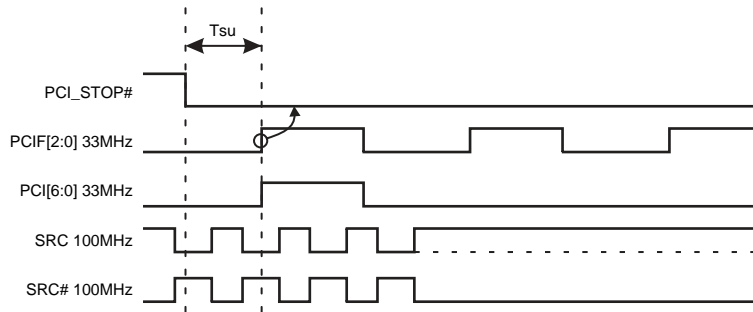

### PCI\_STOP# - De-assertion

The de-assertion of the PCI\_Stop# signal is to be sampled on the rising edge of the PCIF free running clock domain. After detecting PCI\_Stop# de-assertion, all PCI[6:0], stoppable PCIF[2:0] and stoppable SRC clocks will resume in a glitch free manner.

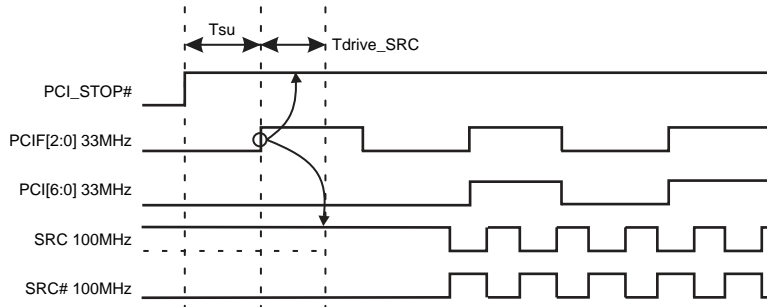

### CPU\_STOP# Functionality

The CPU\_STOP# signal is an active low input controlling the CPU outputs. This signal can be asserted asynchronously.

CPU_STOP#	CPU	CPU #	SRC	SRC#	3V66	PCIF/PCI	USB/DOT	REF	Note
1	Normal	Normal	Normal	Normal	66MHz	33MHz	48MHz	14.318MHz	
0	Iref * 6 or Float	Low	Normal	Normal	66MHz	33MHz	48MHz	14.318MHz	

### CPU\_STOP# - Assertion (transition from '1' to '0')

Asserting CPU\_STOP# pin stops all CPU outputs that are set to be stoppable after their next transition. When the I2C CPU\_STOP tri-state bit corresponding to the CPU output of interest is programmed to a '0', CPU output will stop CPU\_True = HIGH and CPU\_Complement = LOW. When the I2C CPU\_Stop tri-state bit corresponding to the CPU output of interest is programmed to a '1', CPU outputs will be tri-stated.

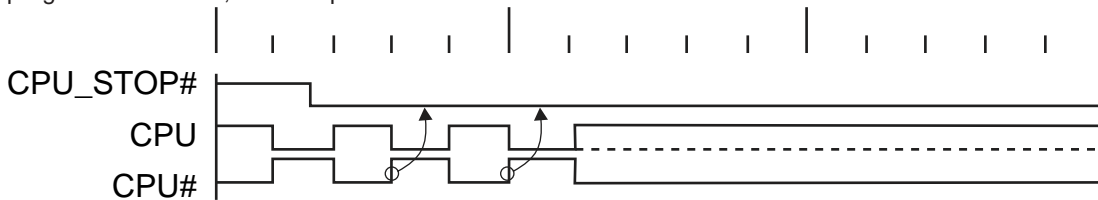

### CPU\_STOP# - De-assertion (transition from '0' to '1')

With the de-assertion of CPU\_Stop# all stopped CPU outputs will resume without a glitch. The maximum latency from the de-assertion to active outputs is 2 - 6 CPU clock periods. If the control register tristate bit corresponding to the output of interest is programmed to '1', then the stopped CPU outputs will be driven High within 10nS of CPU\_Stop# de-assertion to a voltage greater than 200mV.

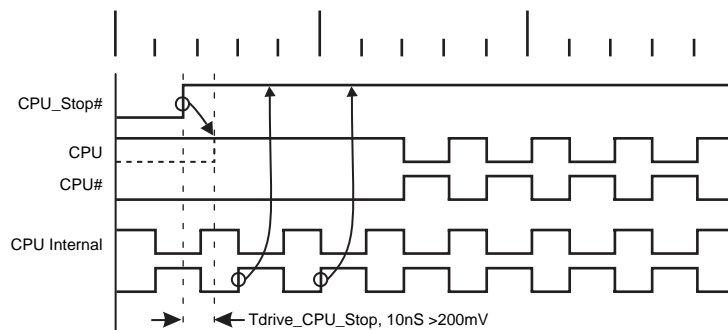

## PD#, Power Down

PD# is an asynchronous active low input used to shut off all clocks cleanly prior to clock power. When PD# is asserted low all clocks will be driven low before turning off the VCO. In PD# de-assertion all clocks will start without glitches.

PWRDWN#	CPU	CPU #	SRC	SRC#	3V66	PCIF/PCI	USB/DOT	REF	Note
1	Normal	Normal	Normal	Normal	66MHz	33MHz	48MHz	14.318MHz	
0	Iref * 2 or Float	Float	Iref * 2 or Float	Float	Low	Low	Low	Low	

Notes:

1. Refer to tristate control of CPU and SRC clocks in section 7.7 for tristate timing and operation.
2. Refer to Control Registers in section 16 for CPU\_Stop, SRC\_Stop and PwrDwn SMBus tristate control addresses.

## PD# Assertion

PD# should be sampled low by 2 consecutive CPU# rising edges before stopping clocks. All single ended clocks will be held low on their next high to low transition.

All differential clocks will be held high on the next high to low transition of the complimentary clock. If the control register determining to drive mode is set to 'tri-state', the differential pair will be stopped in tri-state mode, undriven.

When the drive mode but corresponding to the CPU or SRC clock of interest is set to '0' the true clock will be driven high at 2 x Iref and the complementary clock will be tristated. If the control register is programmed to '1' both clocks will be tristated.

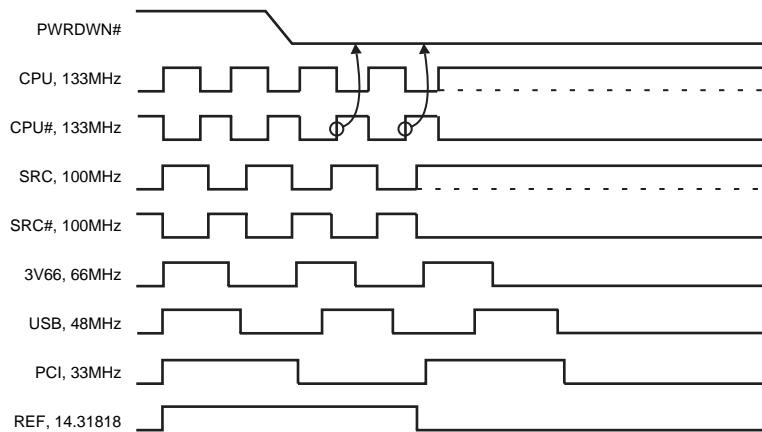



### PD# De-assertion

The time from the de-assertion of PD# or until power supply ramps to get stable clocks will be less than 1.8ms. If the drive mode control bit for PD# tristate is programmed to '1' the stopped differential pair must first be driven high to a minimum of 200mV in less than 300µs of PD# deassertion.

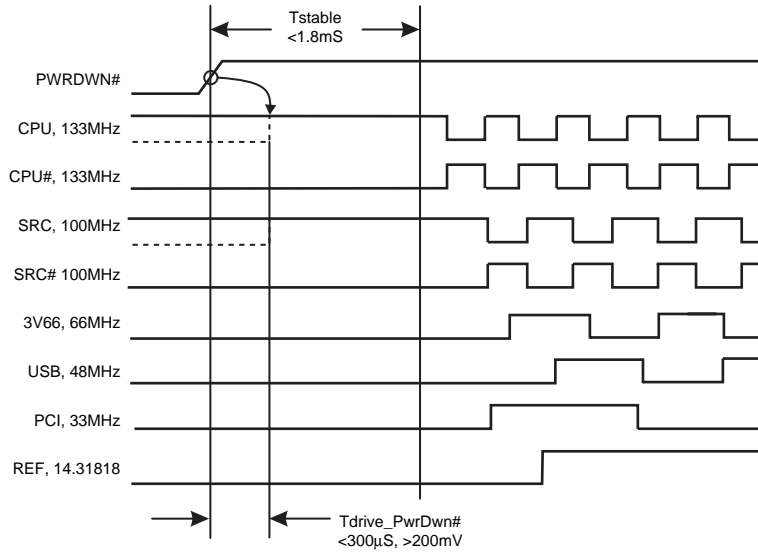

### 3V66\_4/VCH Pin Functionality

The 3V66\_4/VCH pin can be configured to be a 66.66MHz modulated output or a non-spread 48MHz output. The default is 3V66 clock. The switching is controlled by Byte 5 Bit 5. If it is set to '1' this pin will output the 48MHz VCH clock. The output will go low on the falling edge of 3V66 for a minimum of 7.49ns. Then the output will transition to 48MHz on the next rising edge of DOT\_48 clock.

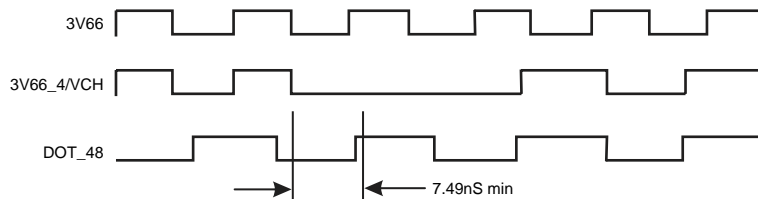

## Differential Clock Tristate

To minimize power consumption, CPU[2:0] clock outputs are individually configurable through SMBus to be driven or tristated during PwrDwn# and CPU\_Stop# mode and the SRC clock is configurable to be driven or tristated during PCI\_Stop# and PwrDwn# mode. Each differential clock (SRC, CPU[2:0]) output can be disabled by setting the corresponding output's register OE bit to "0" (disable). Disabled outputs are to be tristated regardless of "CPU\_Stop", "SRC\_Stop" and "PwrDwn" register bit settings.

Signal	Pin PD#	Pin CPU_Stop#	CPU_Stop Tristate Bit	PwrDwn Tristate Bit	Non-Stoppable Outputs	Stoppable Outputs
CPU[2:0]	1	1	X	X	Running	Running
CPU[2:0]	1	0	0	X	Running	Driven @ Iref x 6
CPU[2:0]	1	0	1	X	Running	Tristate
CPU[2:0]	0	X	X	0	Driven @ Iref x 2	Driven @ Iref x 2
CPU[2:0]	0	X	X	1	Tristate	Tristate

**Notes:**

1. Each output has four corresponding control register bits, OE, PwrDwn, CPU\_Stop and "Free Running"
2. Iref x 6 and Iref x 2 is the output current in the corresponding mode
3. See Control Registers section for bit address

Signal	Pin PD#	Pin PCI_Stop#	PCI_Stop Tristate Bit	PwrDwn Tristate Bit	Non-Stoppable Output	Stoppable Output
SRC	1	1	X	X	Running	Running
SRC	1	0	0	X	Running	Driven @ Iref x 6
SRC	1	0	1	X	Running	Tristate
SRC	0	X	X	0	Driven @ Iref x 2	Driven @ Iref x 2
SRC	0	X	X	1	Tristate	Tristate

**Notes:**

1. SRC output has four corresponding control register bits, OE, PwrDwn, SRC\_Stop and "Free Running"
2. Iref x 6 and Iref x 2 is the output current in the corresponding mode
3. See Control Registers section for bit address

### CPU Clock Tristate Timing

The following diagrams illustrate CPU clock timing during CPU\_Stop# and PwrDwn# modes with CPU\_PwrDwn and CPU\_Stop tristate control bits set to driven or tristate in byte 2 of the control register.

#### CPU\_Stop = Driven, CPU\_Pwrdown = Driven

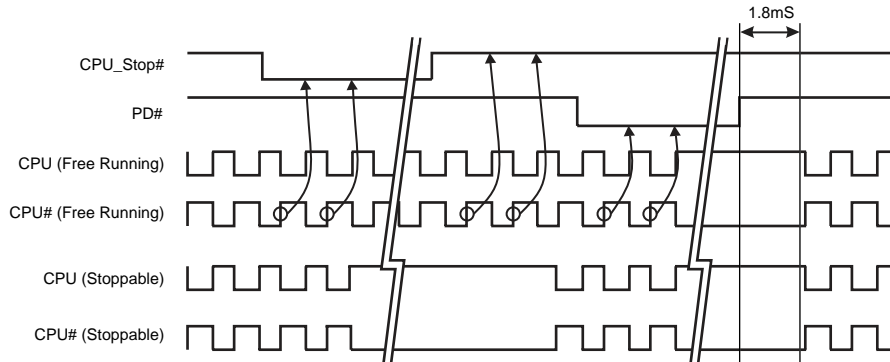

**Notes:**

1. When both bits (CPU\_Stop & CPU\_Pwrdown tristate bits) are low, the clock chip will never tristate CPU output clocks (assuming clock's OE bit is set to "1")

#### CPU\_Stop = Tristate, CPU\_Pwrdown = Driven

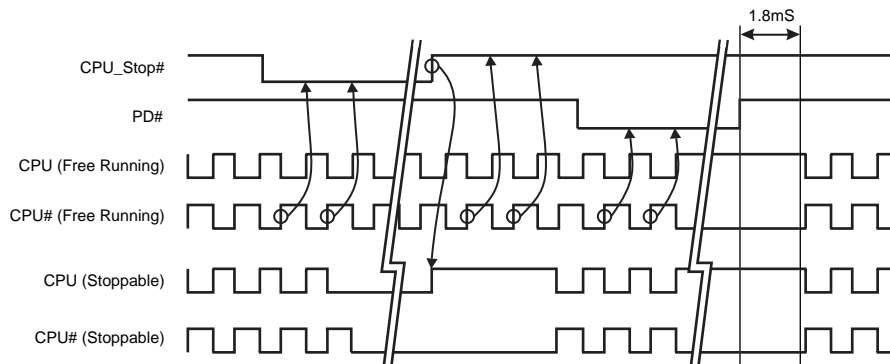

**Notes:**

1. Tristate outputs are pulled low by output termination resistors as shown here.

**CPU\_Stop = Driven, CPU\_Pwrdsn = Tristate**

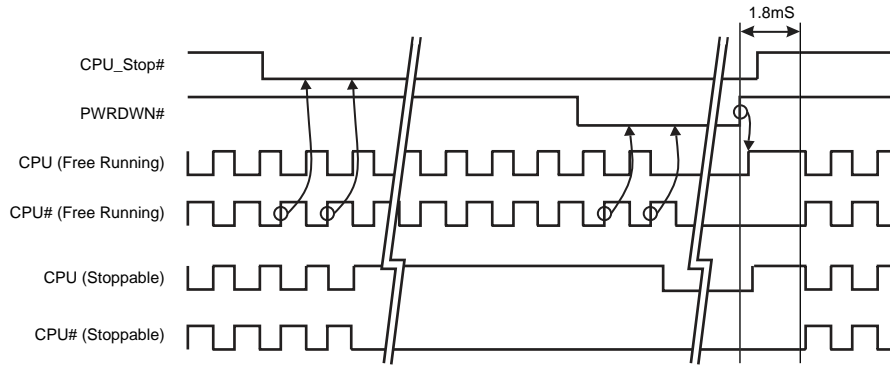

**Notes:**

1. When CPU\_Pwrdsn is set to tristate and CPU\_Stop is set to driven, the clock chip will tristate outputs only during the assertion of PWRDWN#. Differential clock behavior during the assertion/de-assertion of CPU\_Stop# will be unaffected.
2. In the case that CPU\_Stop# is de-asserted during the 1.8mS PWRDWN# de-assertion resume delay, the clock chip can sample the CPU\_Stop# high with the internal rising edges of clock#. This will result in CPU clocks resuming immediately after the 1.8mS windows expires. This applies to all control register bit changes as well.
3. Tristate outputs are pulled low by output termination resistors as shown here.

**CPU\_Stop = Tristate, CPU\_Pwrdsn = Tristate**

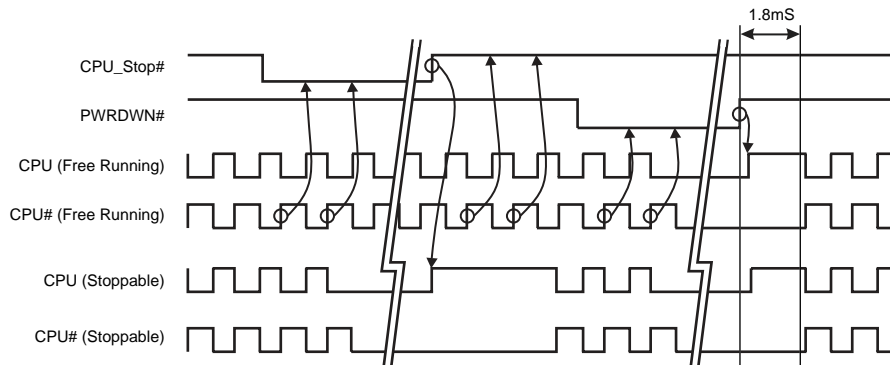

**Notes:**

1. When CPU\_Stop and CPU\_Pwrdsn bits are set to tristate, the clock chip will tristate the outputs during the assertion of CPU\_Stop# and PWRDWN#.
2. Tristate outputs are pulled low by output termination resistors as shown here.

### SRC Clock Tristate Timing

The following diagrams illustrate SRC clock timing during PCI\_Stop# and PwrDwn# modes with SRC\_Pwrdown and SRC\_Stop tristate control bits set to driven or tristate in byte 2 of the control register.

#### SRC\_Stop = Driven, SRC\_Pwrdown = Driven

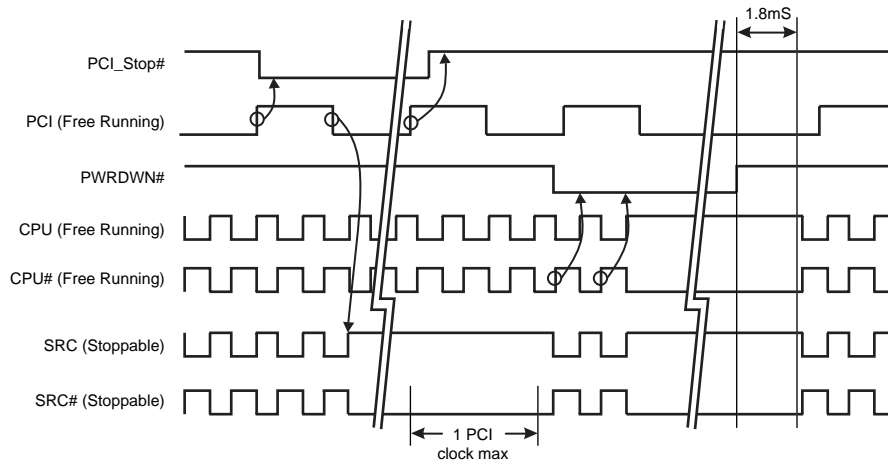

**Notes:**

1. When both bits (SRC\_Stop & SRC\_Pwrdown tristate bits) are set to driven, the clock chip will never tristate the SRC output clock (assuming clock's OE bit is set to "1")

#### SRC\_Stop = Tristate, Pwrdown = Tristate

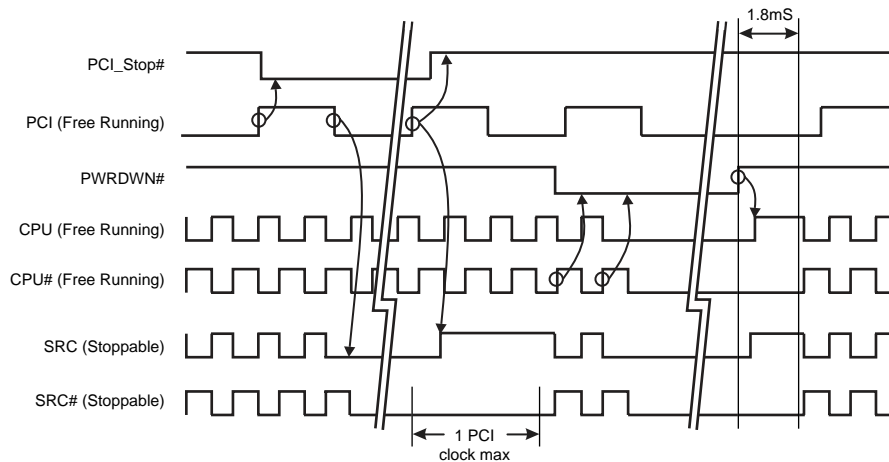

**Notes:**

1. When SRC\_Stop and SRC\_Pwrdown bits are set to tristate, the clock chip will tristate outputs during the assertion of PCI\_Stop# and PWRDWN#.
2. Tristate outputs are pulled low by output termination resistors as shown here.

**PCI\_STOP Asserted**  
**SRC\_Stop = Tristate, SRC\_Pwrdown = Tristate**

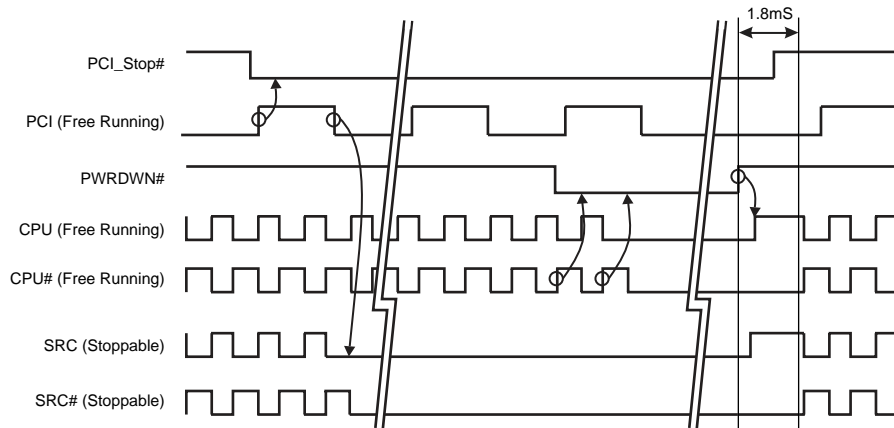

**Notes:**

1. When SRC\_Pwrdown and SRC\_Stop are set to tristate, the clock chip will tristate outputs during the assertion of PCI\_Stop# and PWRDWN#.
2. In the case that PCI\_Stop# is de-asserted during the 1.8mS PWRDWN# de-assertion resume delay, the clock chip can sample the PCI\_Stop# high with the internal rising edges of CPU clock#. This will result in SRC clocks resuming immediately after the 1.8mS window expires. This applies to all control register bit changes as well.
3. Tristate outputs are pulled low by output termination resistors as shown here.

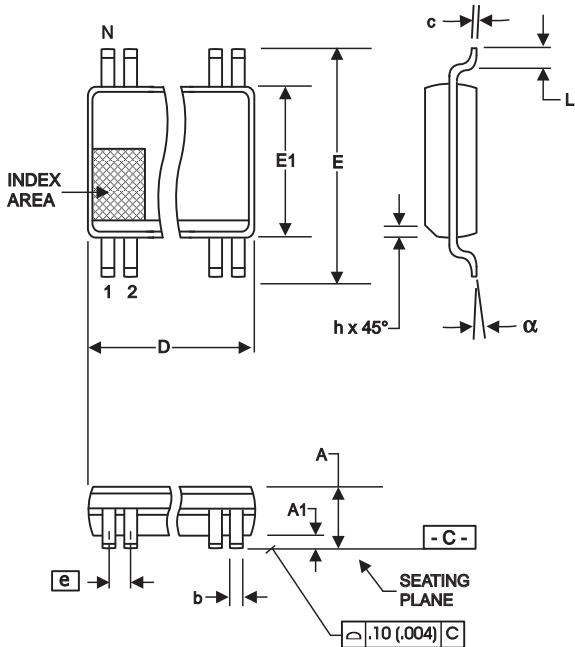

**56-Lead, 300 mil Body, 25 mil, SSOP**

SYMBOL	In Millimeters COMMON DIMENSIONS		In Inches COMMON DIMENSIONS	
	MIN	MAX	MIN	MAX
A	2.41	2.80	.095	.110
A1	0.20	0.40	.008	.016
b	0.20	0.34	.008	.0135
c	0.13	0.25	.005	.010
D	SEE VARIATIONS		SEE VARIATIONS	
E	10.03	10.68	.395	.420
E1	7.40	7.60	.291	.299
e	0.635 BASIC		0.025 BASIC	
h	0.38	0.64	.015	.025
L	0.50	1.02	.020	.040
N	SEE VARIATIONS		SEE VARIATIONS	
a	0°	8°	0°	8°

**VARIATIONS**

N	D mm.		D (inch)	
	MIN	MAX	MIN	MAX
56	18.31	18.55	.720	.730

Reference Doc.: JEDEC Publication 95, MO-118

10-0034

## Ordering Information

**ICS952601yFLFT**

Example:

**ICS XXXX y F LFT**

- \_\_\_\_\_ Designation for tape and reel packaging
- \_\_\_\_\_ Lead Free (optional)
- \_\_\_\_\_ Package Type  
F = SSOP
- \_\_\_\_\_ Revision Designator (will not correlate with datasheet revision)
- \_\_\_\_\_ Device Type (consists of 3 or 4 digit numbers)
- \_\_\_\_\_ Prefix  
ICS, AV = Standard Device

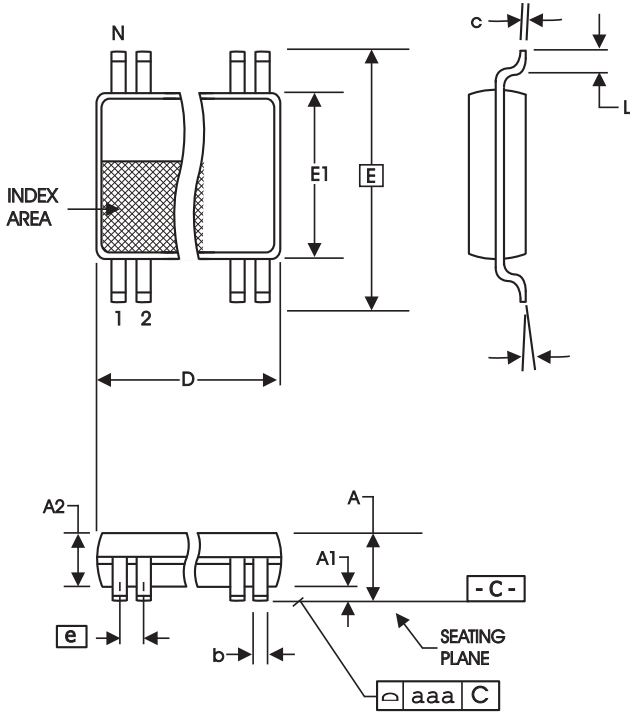

**56-Lead 6.10 mm. Body, 0.50 mm. Pitch TSSOP  
(240 mil) (20 mil)**

SYMBOL	In Millimeters		In Inches	
	COMMON DIMENSIONS		COMMON DIMENSIONS	
	MIN	MAX	MIN	MAX
A	--	1.20	--	.047
A1	0.05	0.15	.002	.006
A2	0.80	1.05	.032	.041
b	0.17	0.27	.007	.011
c	0.09	0.20	.0035	.008
D	SEE VARIATIONS		SEE VARIATIONS	
E	8.10 BASIC		0.319 BASIC	
E1	6.00	6.20	.236	.244
e	0.50 BASIC		0.020 BASIC	
L	0.45	0.75	.018	.030
N	SEE VARIATIONS		SEE VARIATIONS	
a	0°	8°	0°	8°
aaa	--	0.10	--	.004

**VARIATIONS**

N	D mm.		D (inch)	
	MIN	MAX	MIN	MAX
56	13.90	14.10	.547	.555

Reference Doc.: JEDEC Publication 95, MO-153

10-0039

**Ordering Information**

**ICS952601yGLFT**

Example:

**ICS XXXX y G LFT**

- ICS: Prefix  
ICS, AV = Standard Device
- XXXX: Device Type (consists of 3 or 4 digit numbers)
- y: Revision Designator (will not correlate with datasheet revision)
- G: Package Type  
G = TSSOP
- LFT: Designation for tape and reel packaging  
Lead Free (optional)