

TOSHIBA BIPOLAR DIGITAL INTEGRATED CIRCUIT SILICON MONOLITHIC

**TD6380P, TD6380N, TD6380Z, TD6381P, TD6381N, TD6381Z,  
TD6382P, TD6382N, TD6382Z**

**FREQUENCY SYNTHESIZER FOR TV / CATV**

A series of TD6380~6382 are a single-chip frequency synthesizer IC, which can configure high-performance frequency synthesizer systems in combination with a 4bit  $\mu$ CPU controller.

This IC integrates high input sensitivity ECL prescaler, I<sup>2</sup>L programmable counter, PLL logic and bandswitch drive decoder in a small package.

**FEATURES**

- High input sensitivity
  - $f_{in} = 80\sim 100\text{MHz}$  : -20dBmW (50 $\Omega$ ) (Min.)
  - $f_{in} = 0.1\sim 1\text{GHz}$  : -27dBmW (50 $\Omega$ ) (Min.)
  - $f_{in} = 1\sim 1.2\text{GHz}$  : -17dBmW (50 $\Omega$ ) (Min.) (TD6381 only)
- Simple control bus : 18/19bit serial input
- 5V single power supply operation
- Bandswitch driver : 4 channels
- The frequency step will be as follows :

IC	CRYSTAL	STEP	MAX. OPERATING FREQUENCY
6380	4.0 MHz	62.5 kHz	1.0 GHz
6381	3.2 MHz	50 kHz	1.2 GHz
6382	4.0 MHz	31.25 kHz	1.0 GHz

(Note) Handle with care as this product is weak at surge voltage.

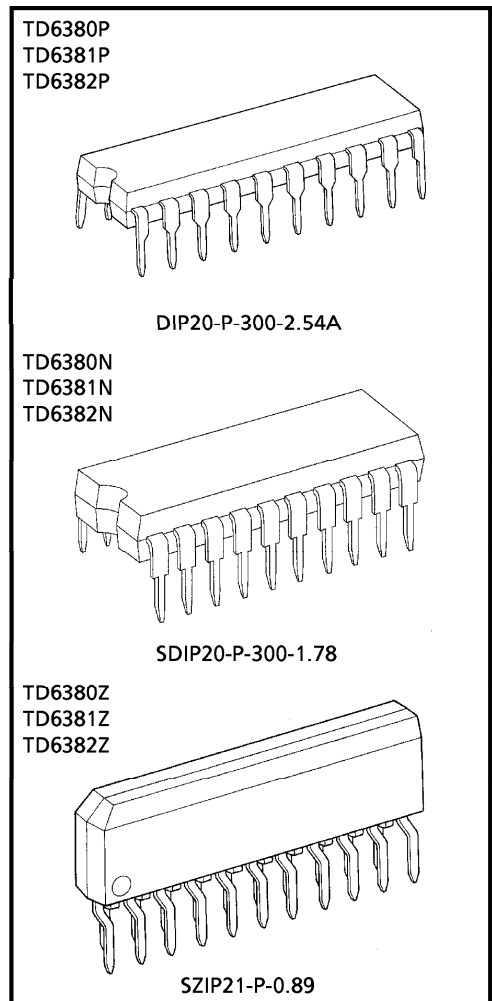

Weight  
 DIP20-P-300-2.54A : 2.25g (Typ.)  
 SDIP20-P-300-1.78 : 1.02g (Typ.)  
 SZIP21-P-0.89 : 1.00g (Typ.)

BLOCK DIAGRAM

TD6380P/N  
TD6381P/N  
TD6382P/N

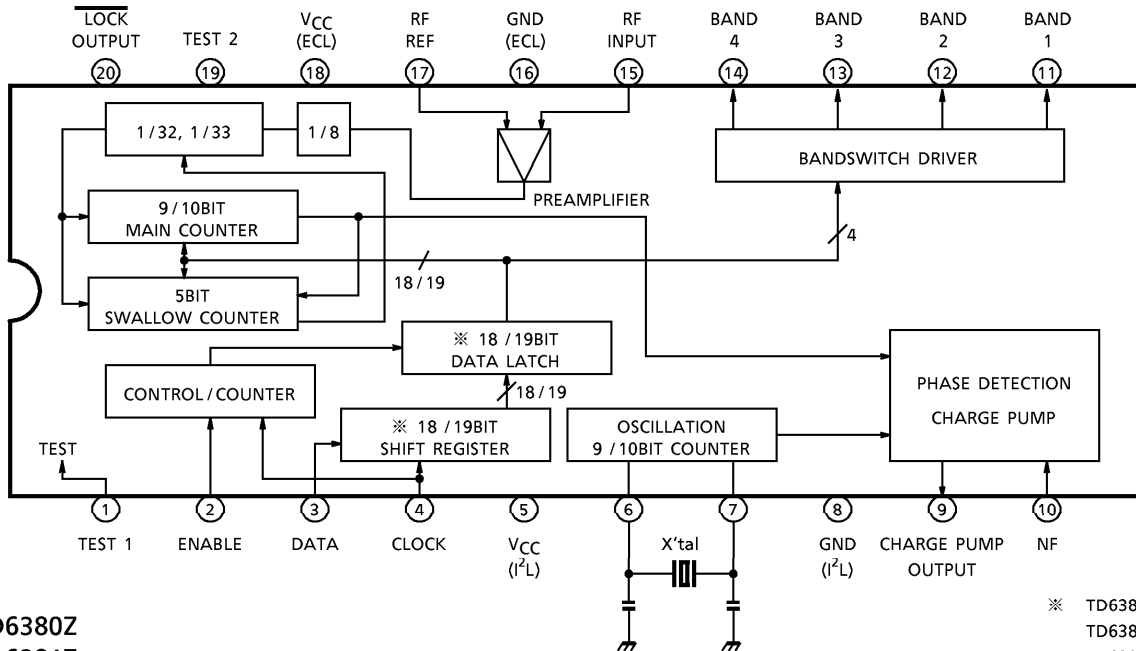

\* TD6380 : 18BIT  
TD6381 : 19BIT  
TD6382 : 19BIT

TD6380Z  
TD6381Z  
TD6382Z

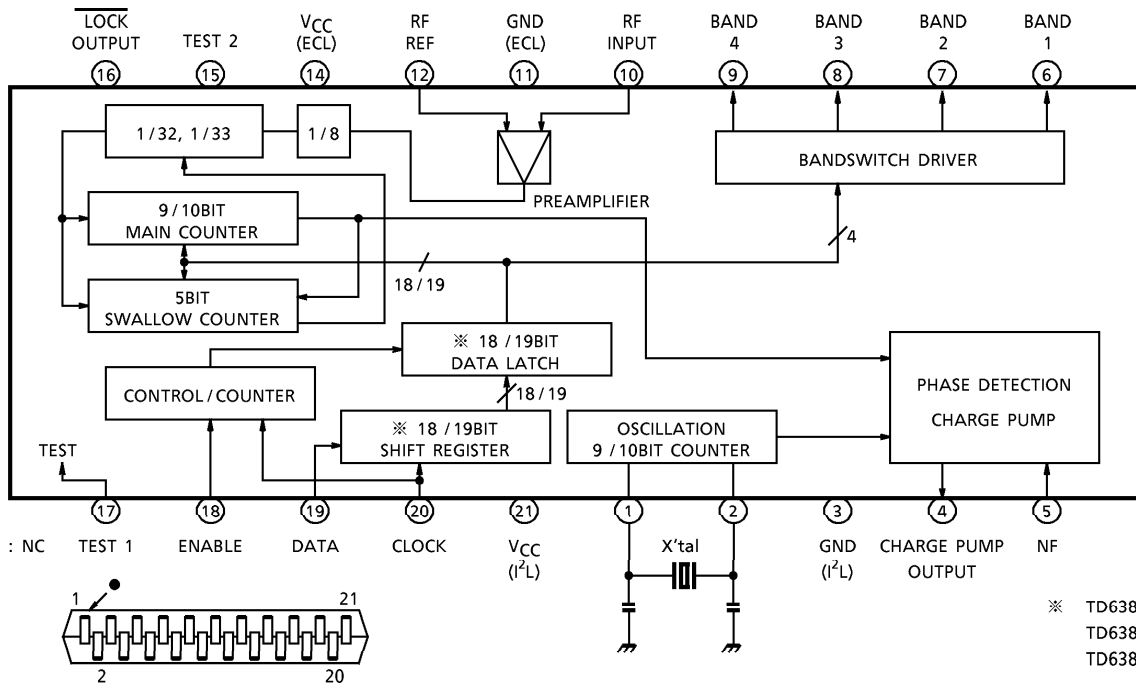

\* TD6380 : 18BIT  
TD6381 : 19BIT  
TD6382 : 19BIT

Pin 13 : NC

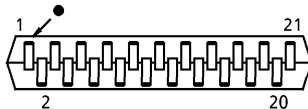

**TERMINAL FUNCTION** (The pin no is indicated in the case of P-package.)

PIN No.	PIN NAME	FUNCTION	INTERFACE CIRCUIT
1	Test Pin 1	<p>Low level : this will be in normal use operation mode when connected to GND or open. In order to prevent a static breakdown, it will be more effective to connect to GND.</p> <p>High level : this will be in test mode when connected to V<sub>CC</sub>.</p>	
2	Enable Input	<p>This is an enable pulse input terminal at normal use operation.</p> <p>This will be a test mode select terminal of test mode by means of the pin 1 mode select pin. In order to prevent a static breakdown, it will be effective to connect in series a resistor of about 1kΩ. The pins 3 and 4 below are the same as this pin.</p>	
3	Data Input	<p>This is a data input terminal in normal mode. In test mode 1 or 2, this will be a main counter output terminal. In test mode 3, this can be an external input terminal of comparison signal of phase comparator (a counter output terminal in normal mode).</p>	
4	Clock Input	<p>This is a clock pulse input terminal in normal mode. In test mode 1 or 2, this will be an output terminal of reference signal whose crystal oscillator is divided by 2<sup>9</sup> or 2<sup>10</sup>. In test mode 3, this can be an input terminal of external reference signal.</p>	
5	Logic V <sub>CC</sub>	<p>This is logic circuit power supply.</p> <p>Connect a bypass capacitor between this pin and pin 8.</p>	<p style="text-align: center;">—</p>

PIN No.	PIN NAME	FUNCTION	INTERFACE CIRCUIT
6, 7	Crystal Oscillation	This is a crystal oscillation terminal to make the reference signal. Make sure to use the logic GND of pin 8 as this oscillates in a big amplitude (about 800mV <sub>p-p</sub> ).	
8	Logic GND	This is used for crystal oscillator GND as is logic GND. Never wire this pin close to the high frequency GND of pin 16.	—
9 10	Frequency phase Comparator Output	In normal use, this compares a high frequency wave input with frequency data and feeds back its difference by means of the supply pump.	
11 ~ 14	Bandswitch	This can make the 4 band switching operate independently. The external driver can freely be operated anywhere between 1~4 pins. Connect an unused pin to the bandswitch power supply.	
15 17	Reference bias by RF Input	This is an input terminal of local oscillation of tuner. In order to prevent disturbance or unwanted resonance, use the pattern of short distance or lead wire for pin 15. Also, connect a bypass capacitor to pin 16 for pin 17 as well.	
16	High Frequency GND	This is mainly used for a bypass capacitor of pins 17 and 18 as is high frequency GND. Also the pattern should be laid out so as to be separated from the logic GND of pin 8.	—

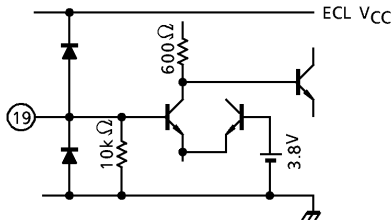
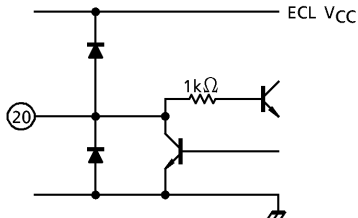
PIN No.	PIN NAME	FUNCTION	INTERFACE CIRCUIT
18	High Frequency VCC	This is high frequency circuit power supply. Connect a bypass capacitor between this pin and pin 8.	—
19	Test Pin 2	This is used only when in test mode 2. This terminal is possible to be input to the main counter without passing through a 1/8 prescaler. Leave this pin open in normal use.	
20	$\overline{\text{Lock}}$ Output	In normal use, a pull up resistor should be connected to VCC. It will be low level only when PLL is locked. In test mode, this will be a test 1 or 2 select terminal and in mode 3, this will be a 256 divided output terminal of high frequency input. This is used for measuring the input sensitivity of a prescaler.	

**OPERATION WHEN IN TEST MODE**

If the test 1 pin (pin 1) is set to high level, this will be in test mode. There are three kinds of test modes as follows :

(1) Mode 1, Mode 2

In mode 1 and 2, a test to inspect the PLL lock condition is executed. After inputting data to the main counter and swallow counter by means of the method indicated in the diagram 2, the test 1 terminal (pin 1) will be set to high level while the enable terminal (pin 2) is held to low level. In this condition, a comparing frequency signal is output to the clock terminal (pin 4) and main counter division signal to the data terminal (pin 3).

The method of inputting to a divider has two kinds : mode 1 and mode 2.

Mode 1. This is the method of inputting from the RF input terminal (pin 15) by setting the lock terminal (pin 20) to high level. The lock condition in normal use operation can be inspected using this method.

Mode 2. This is the method of directly inputting to a 1/32 and 1/33 divider from the test 2 terminal (pin 19) without passing through a 1/8 prescaler by setting the lock terminal (pin 20) to low level.

The input level should be indicated in the diagram 3.

**(2) Mode 3**

In mode 3, a prescaler, phase comparator, and charge pump will be tested.

If both test 1 terminal (pin 1) and enable terminal (pin 2) are set to high level, these will be in mode 3. The clock terminal (pin 4) is a comparison reference frequency signal input of phase comparator, the data terminal (pin 3) is the compared frequency signal input, and the lock terminal (pin 20) is a prescaler output (the fixed dividing ratio of 1/256).

The output polarity of phase comparator is as follows :

INPUT FREQUENCY	CHARGE PUMP OUTPUT PIN (Pin 9)
Input frequency > Programmed frequency	High level
Input frequency < Programmed frequency	Low level

**TEST MODE**

PIN NAME	NORMAL	MODE 1	MODE 2	MODE 3
Test 1 (pin 1)	L	H	H	H
Enable (pin 2)	Enable	L	L	H
Lock (pin 20)	$\overline{\text{Lock}}$	H (pin 15 input)	L (pin 19 input)	1/256 output (pin 15 input)
Clock (pin 4)	Clock input	Comparison reference signal output 80 : 7.8125kHz 81 : 6.25kHz 82 : 3.90625kHz	Comparison reference signal output 80 : 7.8125kHz 81 : 6.25kHz 82 : 3.90625kHz	P.D. Reference signal input
Data (pin 3)	Data input	Main counter output	Main counter output	P.D. Comparison signal input
Test 2 (pin 19)	Inhibit	Inhibit	Divider input	Inhibit
RF input (pin 15)	RF input	RF input	Inhibit	RF input

**THE METHOD OF INPUTTING DATA**

The method of inputting data will be indicated in the diagram 1.

**LOCK FREQUENCY CALCULATION METHOD**

The lock frequency can be calculated in the following formula :

$$f_{OSC} = f_r \times 8 \times (32M + S)$$

- $f_{OSC}$  : The oscillation frequency of VCO (the input frequency of a prescaler)
- $f_r$  : Reference frequency ; it will be  $1/2^9$  ( $2^{10}$ ) of the oscillation frequency of a crystal oscillator.
- M : Preset value of Main counter ; The 10 (9) bits between MSB to MSB-10 (9).  
Input  $32 \leq M \leq 511$  or 1023 value in binary.
- S : Preset value of Swallow counter ; The 5 bits between MSB-10 (9) to LSB.  
Input  $0 \leq S \leq 31$  value in binary.

			TD6380	TD6381	TD6382
Programmable Counter			14bit	15bit	15bit
	Main	M	9bit	10bit	10bit
	Swallow	S	5bit	5bit	5bit
Reference Frequency		$f_r$	7.8125kHz (4.0MHz / $2^9$ )	6.25kHz (3.2MHz / $2^9$ )	3.90625kHz (4.0MHz / $2^{10}$ )
Frequency Step			62.5kHz	50kHz	31.25kHz

For example, when  $f_{OSC} = 801\text{MHz}$  is received at the reference frequency of 7.8125kHz (TD6380),

$$801 \times 10^3 = 7.8125 \times 8 \times (32M + S)$$

$$32M + S = 12816$$

$$M = 400_{(10)} = 110010000_{(2)}$$

$$S = 16_{(10)} = 10000_{(2)}$$

Further, if the band "4" is sed, the received data will be as follows :

1000 110010000 10000  
 BAND      MAIN COUNTER      SWALLOW COUNTER

DIAGRAM 1. Normal use

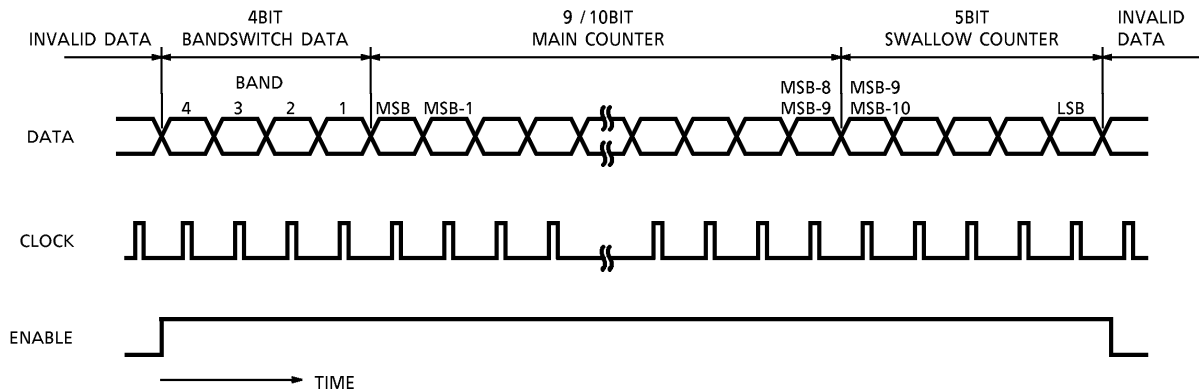

DIAGRAM 2. Test mode (Mode 1, 2)

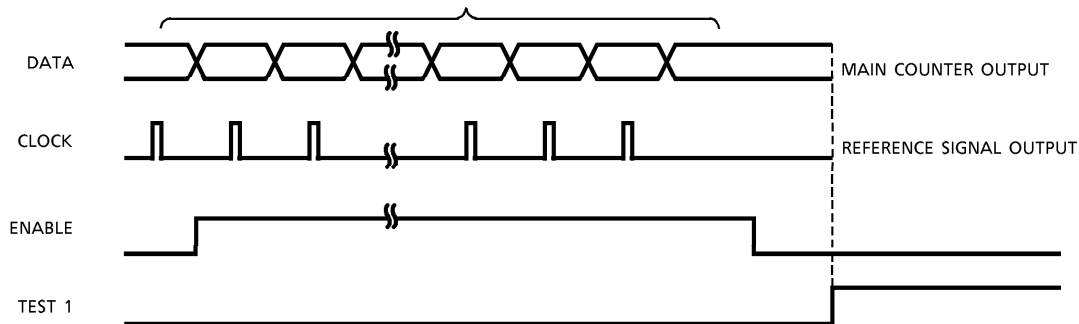
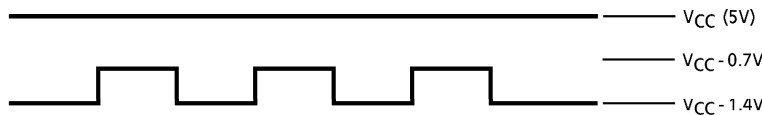

DIAGRAM 3. 1/32, 1/33 input level



MAXIMUM RATINGS (Ta = 25°C)

CHARACTERISTIC	SYMBOL	RATING	UNIT
Supply Voltage	V <sub>CC</sub>	6.5	V
ECL Input Voltage	V <sub>in1</sub>	2.0	V <sub>p-p</sub>
Logic Input Voltage	V <sub>in2</sub>	-0.3~V <sub>CC</sub>	V
Power Dissipation	P <sub>D</sub>	(Note 1)	W
Operating Temperature	T <sub>opr</sub>	-20~75	°C
Storage Temperature	T <sub>stg</sub>	-55~150	°C

(Note 1) P-type : 1.4W, N-type : 1.2W, Z-type : 890mW

(Note 2) When using the device at above Ta = 25°C, decrease the power dissipation by 11.2mW for P-type and 9.5mW for N-type for each increase of 1°C.

(Note 3) Handle with care as this product is weak at surge voltage.



**RECOMMENDED SUPPLY VOLTAGE**

(The pin no. is indicated in the case of P-package.)

PIN No.	PIN NAME	MIN.	TYP.	MAX.	UNIT
5	ECL V <sub>CC</sub>	4.5	5	5.5	V
18	I <sup>2</sup> L V <sub>CC</sub>	4.5	5	5.5	V

**ELECTRICAL CHARACTERISTICS (V<sub>CC</sub> = 5V, T<sub>a</sub> = 25°C)**

CHARACTERISTIC		SYMBOL	TEST CIRCUIT	TEST CONDITION	MIN.	TYP.	MAX.	UNIT
Supply Current	(ECL)	I <sub>CC1</sub>	—		14	40	66	mA
	(I <sup>2</sup> L)	I <sub>CC2</sub>	—		6	13	20	
Bandswitch Max. Voltage		V <sub>B</sub> MAX.	—	Band 1~4	12	—	15	V
DC Voltage		V <sub>15</sub>	—	—	1.7	2.0	2.3	V
		V <sub>17</sub>	—	—	1.7	2.0	2.3	
DC Current High Level		I <sub>IH</sub>	—	V <sub>in</sub> = 5V (Note 1)	—	180	300	μA
Input Voltage	"H" Level	V <sub>IH</sub>	—	(Note 1)	3.0	—	—	V
	"L" Level	V <sub>IL</sub>	—		—	—	0.8	
Input Voltage	"H" Level	V <sub>OH</sub>	1	(Note 2)	3.8	—	—	V
	"L" Level	V <sub>OL</sub>	1		—	—	0.5	
N/F Leak Current		I <sub>L</sub>	—	(Note 3)	-0.2	—	0.2	μA
RF Input Sensitivity		V <sub>in1</sub>	3	f <sub>in</sub> = 80-100MHz	-20	—	3	dBmW (50Ω)
		V <sub>in2</sub>	3	f <sub>in</sub> = 100-1000MHz	-27	—	3	
		V <sub>in3</sub>	3	f <sub>in</sub> = 1~1.2GHz	-17	—	3	
Setup Time		T <sub>s</sub>	—	Data timing chart	2	—	—	μs
Enable Hold Time		T <sub>sL</sub>	—		2	—	—	
Enable Inhibit Time		T <sub>NE</sub>	—		6	—	—	
Clock Inhibit Time		T <sub>NC</sub>	—		6	—	—	
Clock Width		T <sub>c</sub>	—		2	—	—	
Enable Setup Time		T <sub>L</sub>	—		10	—	—	
Data Hold Time		T <sub>H</sub>	—		2	—	—	

(Note 1) TEST1, Enable, Clock, Lock : applied to input mode.

(Note 2) Data, Clock, Lock : applied to output mode.

(Note 3) Pin 10 : 2.1V, Pin 9 : Open

**TEST CIRCUIT 1**

Test Mode (The pin no. is indicated in the case of P-package.)

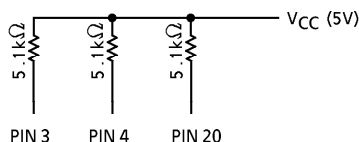

**TEST CIRCUIT 2**  
Supply test circuit

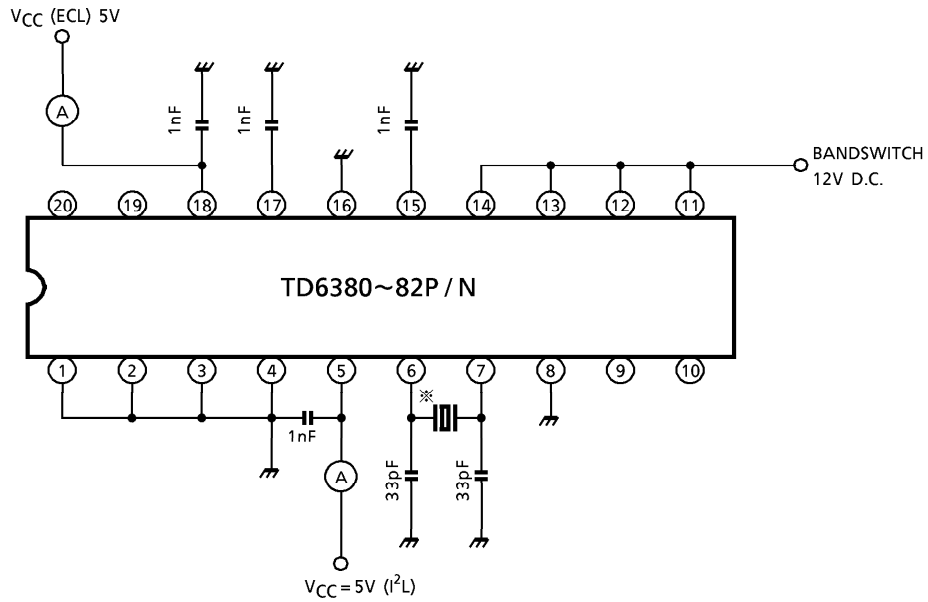

※ Crystal oscillator specification

TD6380	: 4.0MHz	} Serial resistance	: Below 100Ω
TD6381	: 3.2MHz		: 16pF ± 1pF
TD6382	: 4.0MHz		: Within ± 25ppm
			Temperature tolerance: Within ± 30ppm (Ta = -20~75°C)

**TEST CIRCUIT 3**  
Input Sensitivity Test Circuit

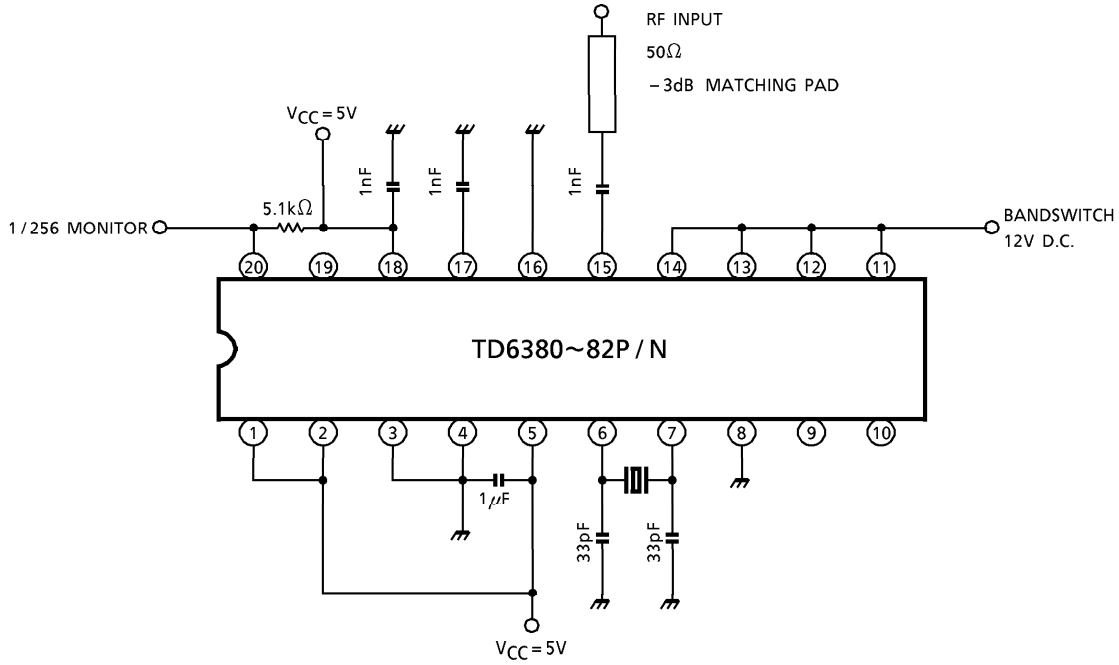

**DATA TIMING CHART (Rising timing)**

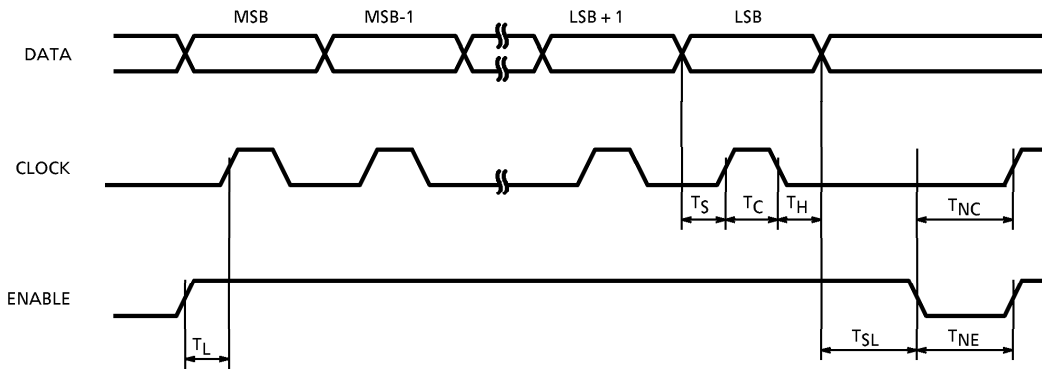

APPLICATION CIRCUIT EXAMPLE OF FREQUENCY SYNTHESIZER

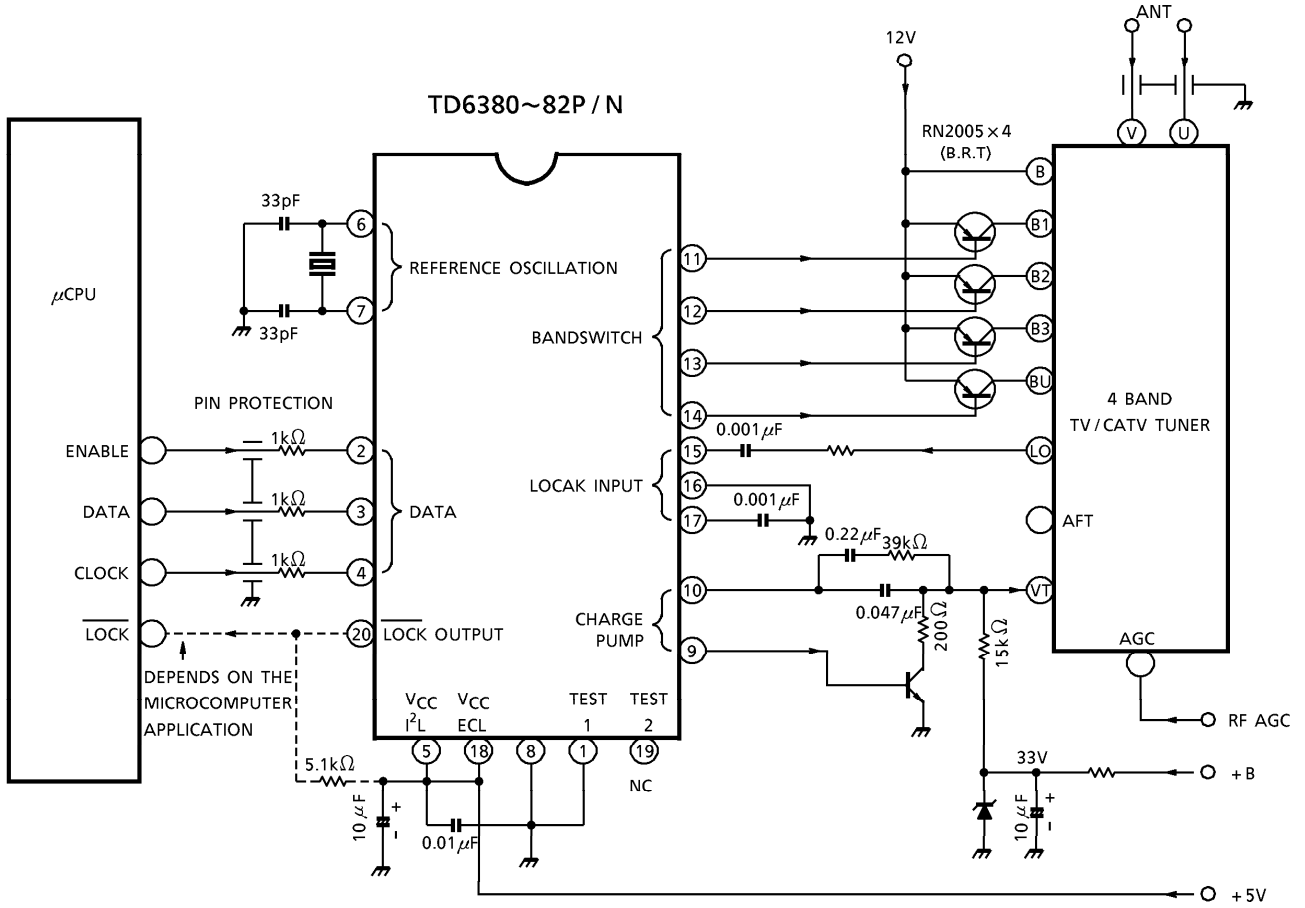

PACKAGE DIMENSIONS  
DIP20-P-300-2.54A

Unit : mm

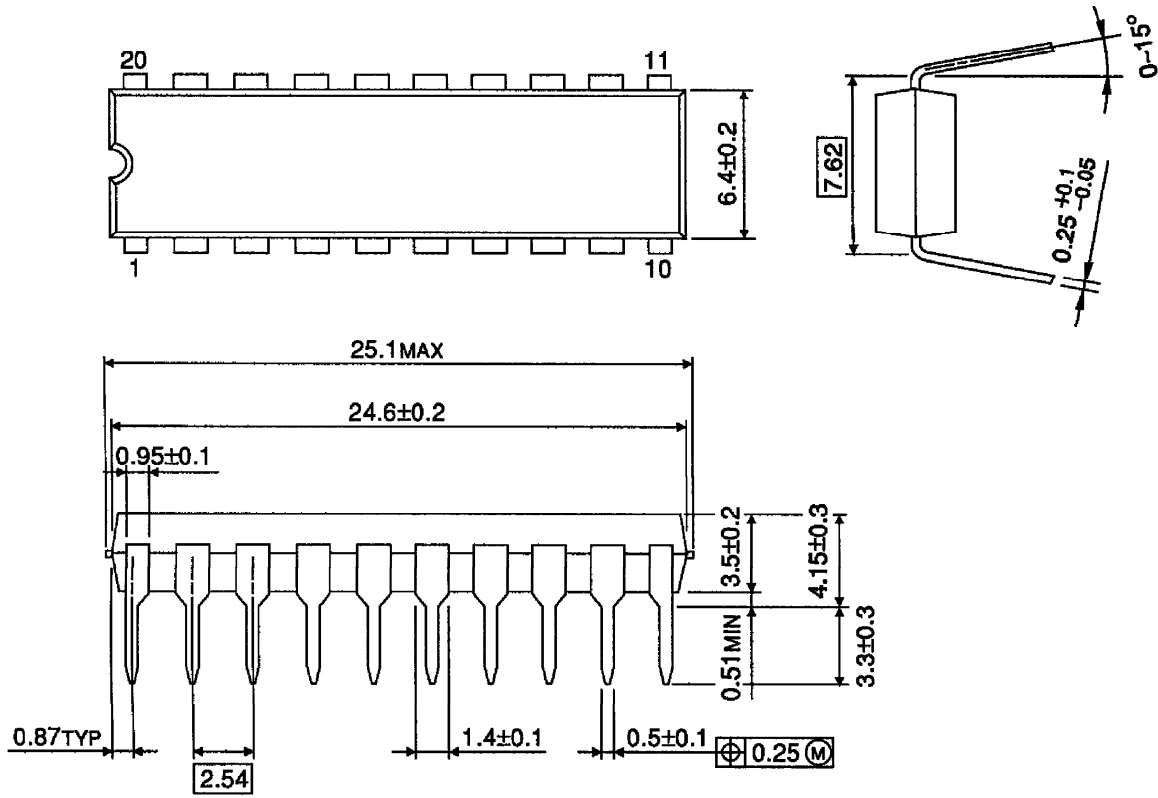

Weight : 2.25g (Typ.)

**PACKAGE DIMENSIONS**  
SDIP20-P-300-1.78

Unit : mm

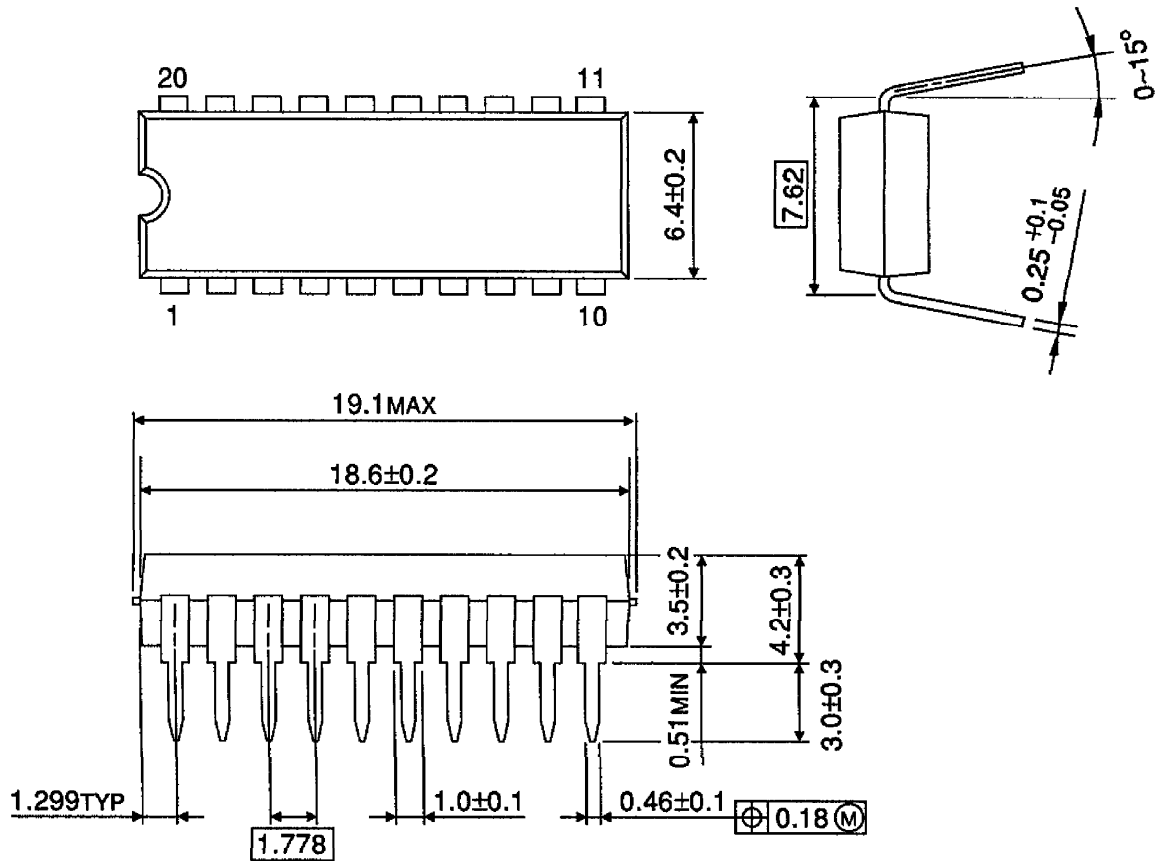

Weight : 1.02g (Typ.)

PACKAGE DIMENSIONS  
SZIP21-P-0.89

Unit : mm

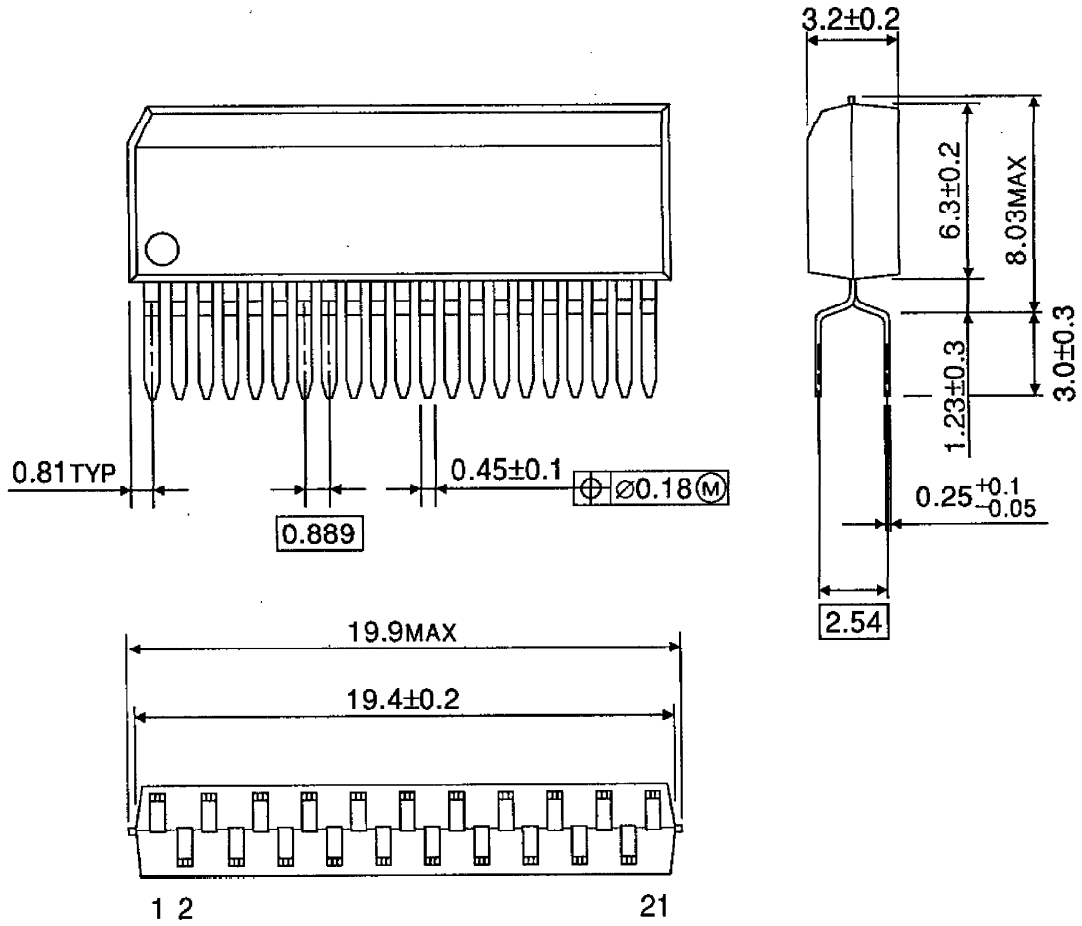

Weight : 1.00g (Typ.)

**RESTRICTIONS ON PRODUCT USE**

000707EBA

- TOSHIBA is continually working to improve the quality and reliability of its products. Nevertheless, semiconductor devices in general can malfunction or fail due to their inherent electrical sensitivity and vulnerability to physical stress. It is the responsibility of the buyer, when utilizing TOSHIBA products, to comply with the standards of safety in making a safe design for the entire system, and to avoid situations in which a malfunction or failure of such TOSHIBA products could cause loss of human life, bodily injury or damage to property. In developing your designs, please ensure that TOSHIBA products are used within specified operating ranges as set forth in the most recent TOSHIBA products specifications. Also, please keep in mind the precautions and conditions set forth in the "Handling Guide for Semiconductor Devices," or "TOSHIBA Semiconductor Reliability Handbook" etc..
- The TOSHIBA products listed in this document are intended for usage in general electronics applications (computer, personal equipment, office equipment, measuring equipment, industrial robotics, domestic appliances, etc.). These TOSHIBA products are neither intended nor warranted for usage in equipment that requires extraordinarily high quality and/or reliability or a malfunction or failure of which may cause loss of human life or bodily injury ("Unintended Usage"). Unintended Usage include atomic energy control instruments, airplane or spaceship instruments, transportation instruments, traffic signal instruments, combustion control instruments, medical instruments, all types of safety devices, etc.. Unintended Usage of TOSHIBA products listed in this document shall be made at the customer's own risk.
- The products described in this document are subject to the foreign exchange and foreign trade laws.
- The information contained herein is presented only as a guide for the applications of our products. No responsibility is assumed by TOSHIBA CORPORATION for any infringements of intellectual property or other rights of the third parties which may result from its use. No license is granted by implication or otherwise under any intellectual property or other rights of TOSHIBA CORPORATION or others.
- The information contained herein is subject to change without notice.