

---

# HA12188AF

Pre-Amplifier and Servo IC for Quadruple-Speed CD-ROM

## HITACHI

ADE-207-183(Z)

1st. Edition  
October 1995

---

### Description

The typical values of built-in capacitances in this IC are reduced 10% compared with those in IC HA12188F. The values of Electrical Characteristics of this IC are same as those of IC HA12188F.

### Functions

- RF amplifier
- Focus error amplifier
- Tracking error amplifier
- FOK detector
- Mirror detector
- Defect detector
- APC amplifier
- Focus, tracking, and sled servo control
- Inner/outer direction detector

### Features

- Built-in variable resistors for adjusting tracking error EF balance, tracking gain, and focus gain
- Single power supply
- Supports double and quadruple speeds
- Few external components
- FP-56 package

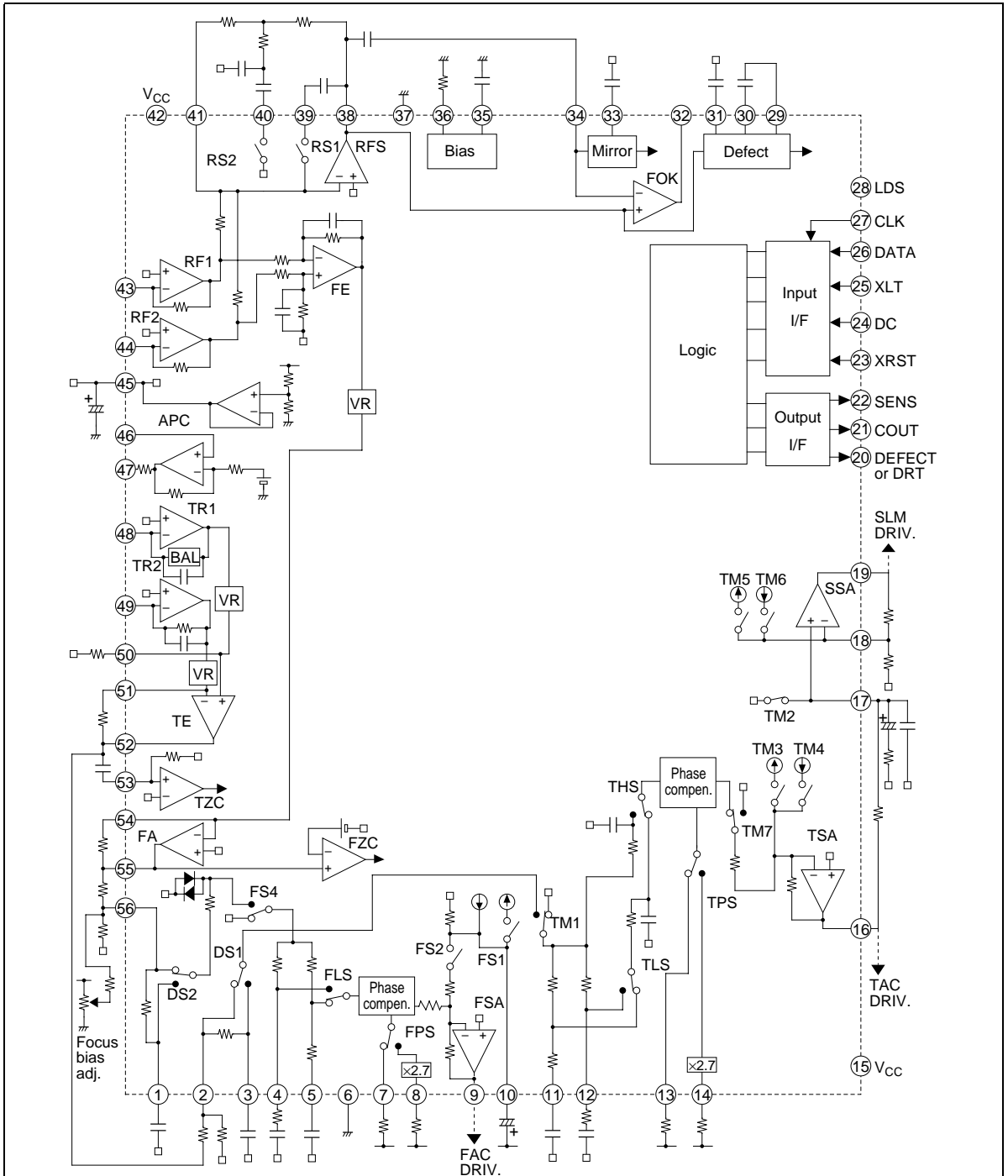

# HA12188AF

## Block Diagram

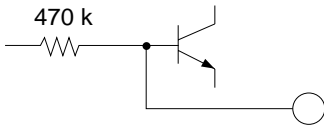
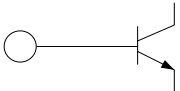

- The states of the IC's internal switches at XRST = "L" are shown at block diagram.
- The black dot symbol of transfer switch shows on state.
- The symbols "↑" mean connecting to V<sub>CC</sub>.
- The symbols "⊞" mean connecting to pin 45.

Pin Descriptions and Equivalent Circuits

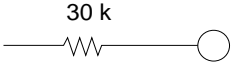
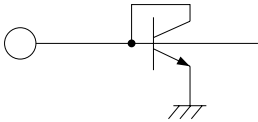
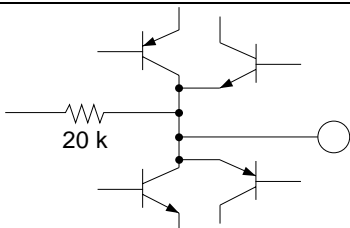
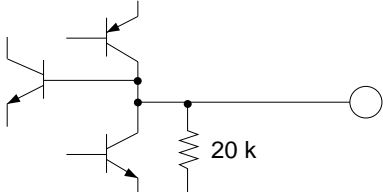
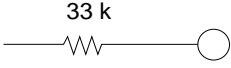
Pin No.	Symbol	Equivalent Circuit	Function
1	FH		Focus error hold signal output
3	TH		Tracking error hold signal output
2	TSI		Tracking servo input
56	FSI		Focus servo input
4	FLS		Focus-servo low-frequency filter resistor & capacitor connection (FLS on)
5	$\overline{\text{FLS}}$		Focus-servo low-frequency filter capacitor connection (FLS off)
6	SGND	—	Servo ground
7	$\overline{\text{FPS}}$		Resistor connection for programming focus-servo phase compensation (FPS off)
8	FPS		Resistor connection for programming focus-servo phase compensation (FPS on)
9	FSA		Focus servo output
10	FS1		FS1 voltage output
11	$\overline{\text{TLS}}$		Tracking servo low-frequency filter capacitor connection (TLS off)

# HA12188AF

## Pin Descriptions and Equivalent Circuits (cont)

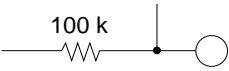
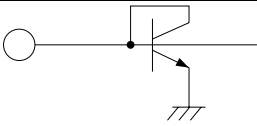
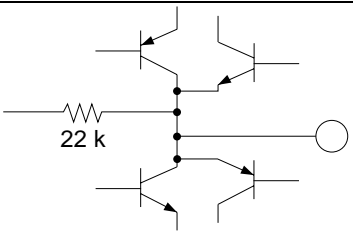
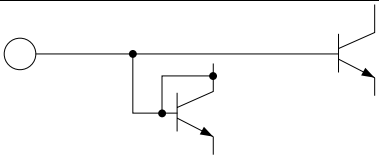
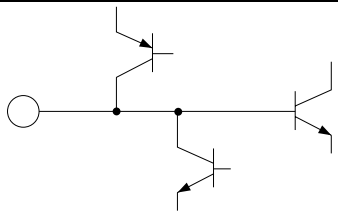
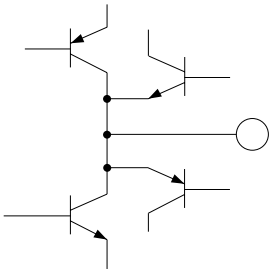
Pin No.	Symbol	Equivalent Circuit	Function
12	TLS		Tracking servo low-frequency filter resistor & capacitor connection (TLS on)
13	TPS		Resistor connection for programming tracking servo phase compensation (TPS off)
14	TPS		Resistor connection for programming tracking servo phase compensation (TPS on)
15	SV <sub>cc</sub>	—	Servo power supply
16	TSA		Tracking servo output
17	TM2		Sled servo input
18	SSM		SSA amplifier inverting input
19	SSA		Sled servo output

Pin Descriptions and Equivalent Circuits (cont)

Pin No.	Symbol	Equivalent Circuit	Function
20	DRT		Defect signal output or inner/outer direction signal output
21	COUT		COUT output
22	SENS		SENS output
23	XRST		Reset input
24	DC		DC input
25	XLT		XLT input
26	DATA		Data input
27	CLK		Clock input
28	LDS		Laser switch input
29	DFIN		Defect comparator input
30	DFO		Defect envelope signal output
31	DFH		Defect hold signal output

# HA12188AF

## Pin Descriptions and Equivalent Circuits (cont)

Pin No.	Symbol	Equivalent Circuit	Function
32	FOK		FOK comparator output
33	MIRH		Mirror hold signal output
34	RFA		RF signal AC input
35	BYPS		Capacitor connection for ripple filter
36	ISSET		Resistor connection for programming reference current
37	PGND	—	Pre-amplifier ground
38	RFO		RF signal output
39	RS1		RS1 switch

Pin Descriptions and Equivalent Circuits (cont)

Pin No.	Symbol	Equivalent Circuit	Function
40	RS2		RS2 switch
41	RFM		RFS amplifier inverting input
42	PV <sub>cc</sub>	—	Pre-amplifier power supply
43	RF1		RF1 amplifier input
44	RF2		RF2 amplifier input
45	V <sub>c</sub>		Voltage reference output
46	MD		APC amplifier input
47	LD		APC amplifier output
48	TR1		TR1 amplifier input
49	TR2		TR2 amplifier input

# HA12188AF

## Pin Descriptions and Equivalent Circuits (cont)

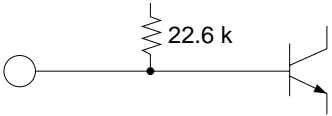
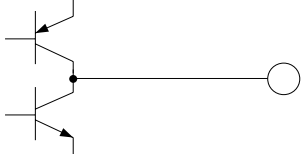
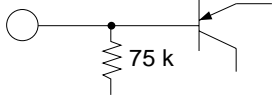
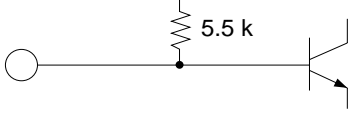
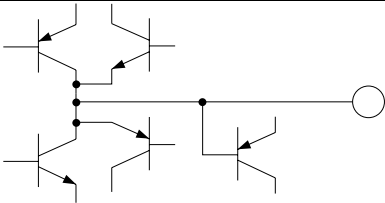
Pin No.	Symbol	Equivalent Circuit	Function
50	TEP		TE amplifier non-inverting input
51	TEM		TE amplifier inverting input
52	TEO		TE amplifier output
53	TZC		TZC comparator input
54	FAM		FA amplifier inverting input
55	FAO		FA amplifier output



## Operation

### 1. Microprocessor Control

The IC's internal switches can be operated by sending control data from a microprocessor. The signal timing is shown in figure 1, and the control commands are listed in table 1.

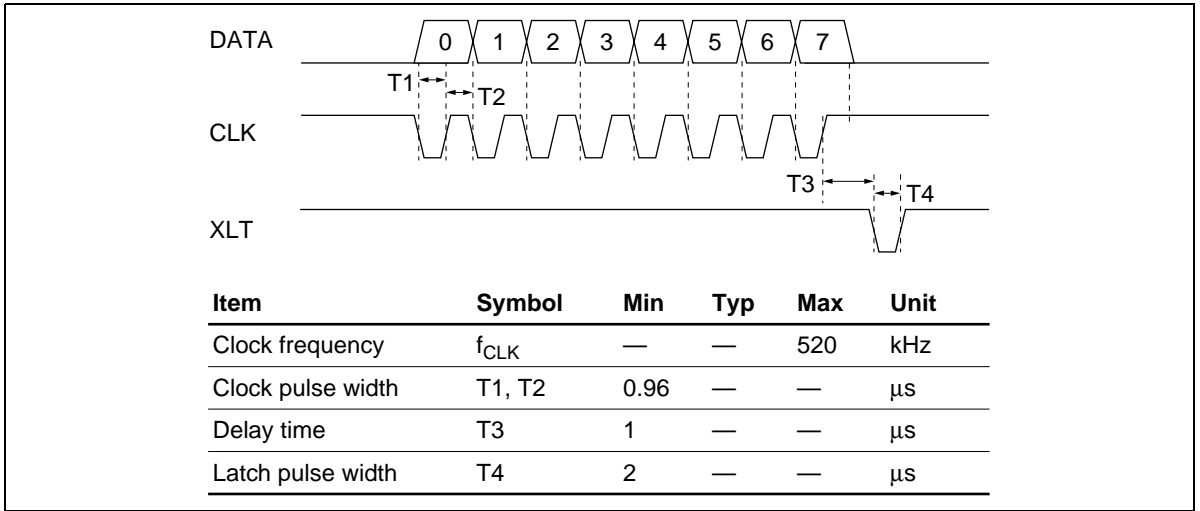

Figure 1 Timing Diagram for Microprocessor Control

Signals from the microprocessor are input at pins 23 to 27. A low input at the XRST pin resets the IC. Normally this pin should be kept high. (See figure 2.)

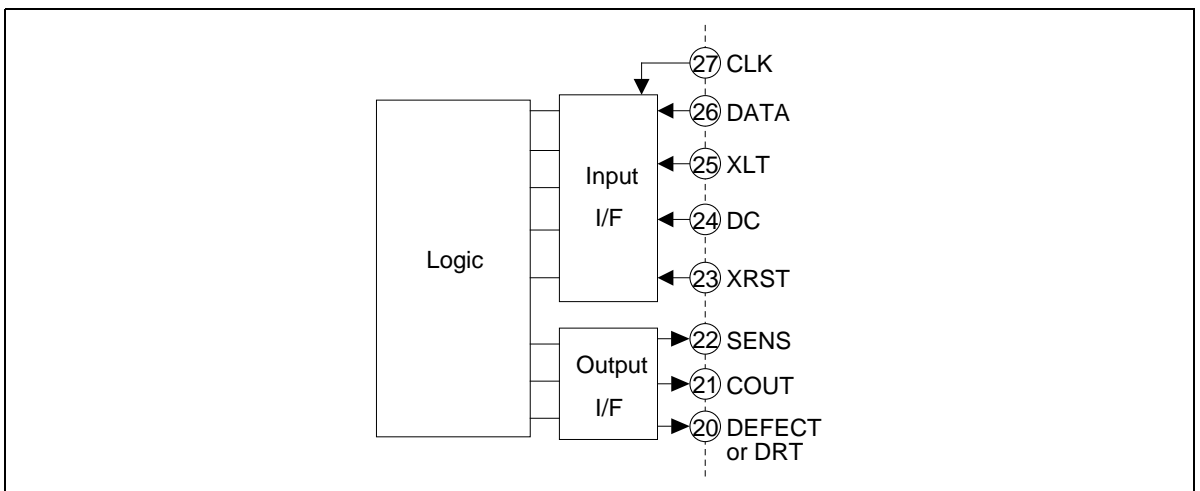

Figure 2 Microprocessor Interface

**Table 1 Microprocessor Control Commands**

	DATA *1						SENS				
	D7	D6	D5	D4	D3	D2		D1	D0		
Focus mode	0	0	0	0	(FS4)	DEFECT OFF *2	(FS2)	(FS1)	FZC		
Tracking mode and FS1 DRT setting	0	0	0	1	DRT *3 0: Defect 1: Direction	(TM7) *4	FS1 current *5	(THS)	H		
Access control mode	0	0	1	0	See table 2				TZC		
Pulse setting mode	0	0	1	1	TM3, TM4 current *6		TM5, TM6 current *6		H		
					D3	D2	Current value	D1		D0	Current value
					0	0	32μA	0		0	32μA
					0	1	16μA	0		1	16μA
					1	0	24μA	1		0	24μA
1	1	8μA	1	1	8μA						
Speed setting mode	0	1	0	0	Mirror *7		Focus tracking	RF	H		
					D3	D2	Mode	(FLS) (FPS)		(RS1) (RS2)	
					0	0	Normal	(TLS) (TPS)			
					0	1	Double				
1	1	Quadruple									
EF balance adjustment	0	1	0	1	(BAL3)	(BAL2)	(BAL1)	(BAL0)	H		
Tracking gain and focus gain adjustment	0	1	1	0	0; Focus gain	(GF2)	(GF1)	(GF0)	H		
					1; Tracking gain	(GT2)	(GT1)	(GT0)	H		

- Notes:
1. The switch name surrounded by circle means that the switch turns on when the corresponding bit is "1". The switch name with bar surrounded by circle means that the switch turns on when the corresponding bit is "0".
  2. "DEFECT OFF" means that switches DS1 and DS2 don't turn on when the corresponding bit is "1". Though the "DEFECT OFF" bit is set, the output at pin 20 is defect signal (in defect signal output mode).
  3. DRT (pin 20) outputs defect signal when the corresponding bit is "0", and outputs direction signal when the corresponding bit is "1".
  4. TM7 can turn on only when COUT is high.
  5. The value of two current sources over switch FS1 are 18 μA(source) 36 μA(sink) when the corresponding bit is "1", and are 9 μA(source) 18 μA(sink) when the corresponding bit is "0".
  6. The current values through switches TM3, TM4, TM5 and TM6 can be selected in four steps.
  7. The speed of Mirror circuit can be selected in three steps. Don't use D3 = "1", D2 = "0" mode.

Table 2 Access Control Mode

	DATA				ST1						ST2						ST3					
	D3	D2	D1	D0	TM6	TM5	TM4	TM3	TM2	TM1	TM6	TM5	TM4	TM3	TM2	TM1	TM6	TM5	TM4	TM3	TM2	TM1
\$20	0	0	0	0					○			○		○								○
\$21	0	0	0	1								○										○
\$22	0	0	1	0		○			○			○	○		○						○	○
\$23	0	0	1	1	○				○		○		○		○						○	○
\$24	0	1	0	0					○	○				○	○							○
\$25	0	1	0	1						○			○									○
\$26	0	1	1	0		○			○	○		○		○	○						○	○
\$27	0	1	1	1	○				○	○	○			○	○						○	○
\$28	1	0	0	0					○	○			○		○							○
\$29	1	0	0	1						○			○									○
\$2A	1	0	1	0		○			○	○		○	○		○						○	○
\$2B	1	0	1	1	○				○	○		○		○							○	○
\$2C	1	1	0	0					○	○				○	○							○
\$2D	1	1	0	1					○					○								○
\$2E	1	1	1	0		○	○		○			○		○	○						○	○
\$2F	1	1	1	1	○		○		○		○		○	○							○	○

A circle means that the switch is ON.

Note: After the microprocessor sends serial data, TM1 to TM6 can be switched among the states listed under ST1 to ST3 by input at the DC pin. First, if the microprocessor sends serial data when DC is high, TM1 to TM6 are placed in the state listed under ST1. When DC is brought low, the states change to the states listed under ST2. Then if DC is brought high again, the states change to the states listed under ST3.

---

# HA12188AF

---

**Table 2-A Access Control Mode Appendix**

1) Tracking servo

<b>DATA</b>		<b>Tracking servo movement</b>
<b>D3</b>	<b>D2</b>	<b>at DC = H (ST1)</b>
0	0	Servo loop off
0	1	Servo loop on
1	0	Servo loop off jump to outside track
1	1	Servo loop off jump to inside track

2) Sled servo

<b>DATA</b>		<b>Sled servo movement</b>
<b>D1</b>	<b>D0</b>	<b>at DC = H (ST1)</b>
0	0	Servo loop off
0	1	Servo loop on
1	0	Servo loop off move to outside track
1	1	Servo loop off move to inside track

## 2. RF and Focus Error Pre-Amplifiers

The main beam output signals from the photodiode IC are led in through resistors at pins 43 and 44. The outputs of amplifiers RF1 and RF2 are summed by amplifier RFS to generate the EFM RF signal. (\*1)

External resistances of pins 43 and 44 and amplifier RFS should be set according to the pick-up so that the RF signal at pin 38 is about  $1.5 V_{op}$  (the difference between the peak level of 11T signal component and the voltage at no signal).

Switches RS1 and RS2 operate together under microprocessor control. For example they are on for normal or double speed, and off for quadruple speed. ON resistance of RS1 is  $1.1k\Omega$  typ and on resistance of RS2 is  $530\Omega$  typ.

Figure 3-A shows the frequency characteristic at pin 38 in the condition of figure 3. (Input resistances of pins 43 and 44 are  $10k\Omega$ .)

External resistances and capacitances should be fitted according to the pick-up. Stray capacitances of board print patterns have influence on this frequency characteristic. Therefore external resistances and capacitances should be set considering stray capacitances.

Amplifier FE subtracts the output of amplifier RF2 from the output of amplifier RF1 to generate the focus error signal. The gain is 0dB. The focus error signal is output as the output of amplifier FA at pin 55, with a gain set by variable resistor VR and the external resistance values. With the external resistors in figure 3, the gain of amplifier FA is 8.7dB (initial value after reset).

Variable resistor VR is controlled by 3-bit data. The gain can be varied from  $-5dB$  to  $+7dB$  with respect to the reset value.

The focus error signal is binarized by comparator FZC, with a  $V_{th}$  equal to  $V_c + 0.38V$ .

A reference voltage of  $1/2 V_{cc}$  is output at pin 45. The IC's internal reference voltage is connected internally.

The feedback resistance of amplifier FA should be set according to the pick-up so that the focus S-curve at pin 55 is about 3V peak-to-peak.

Note: 1 The sink current of amplifier RFS is about 1mA. When load capacitance of pin 38 is big because of wiring with CD DSP LSI etc, please use buffer amplifier. (for example emitter follower transistor)

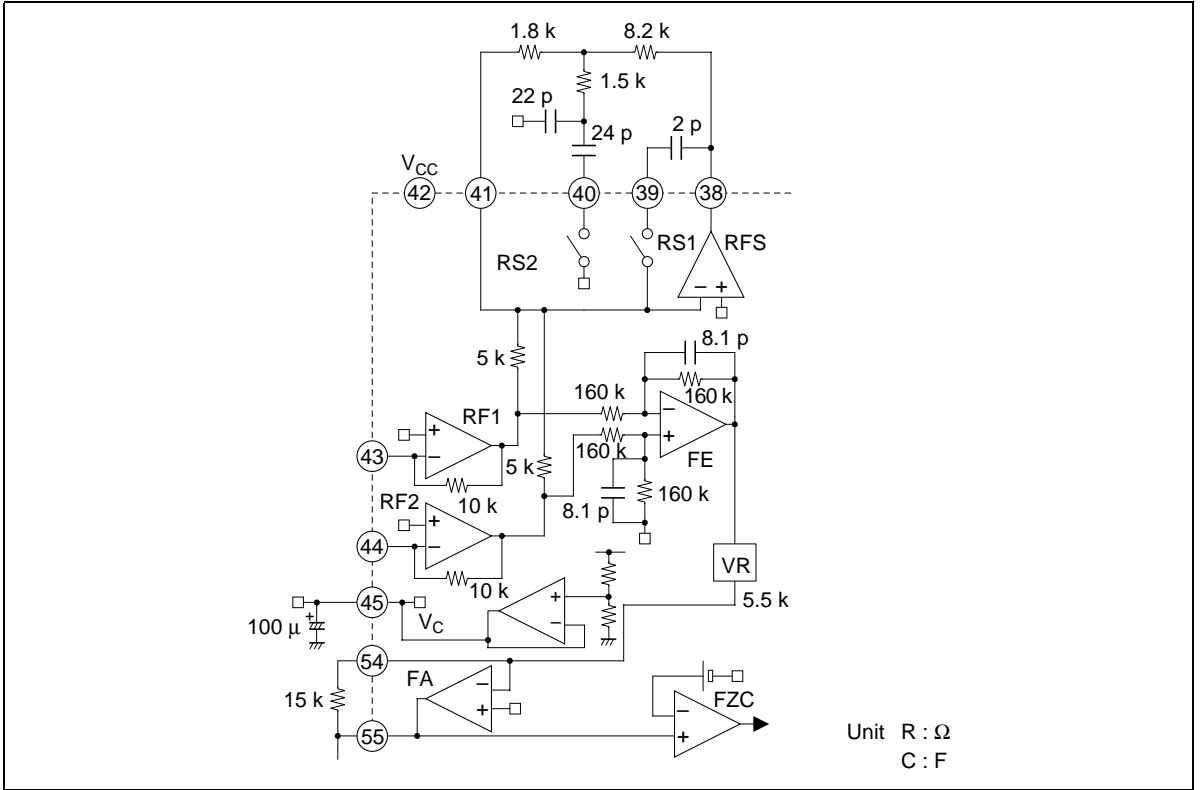

Figure 3 RF and Focus Error Pre-Amplifiers

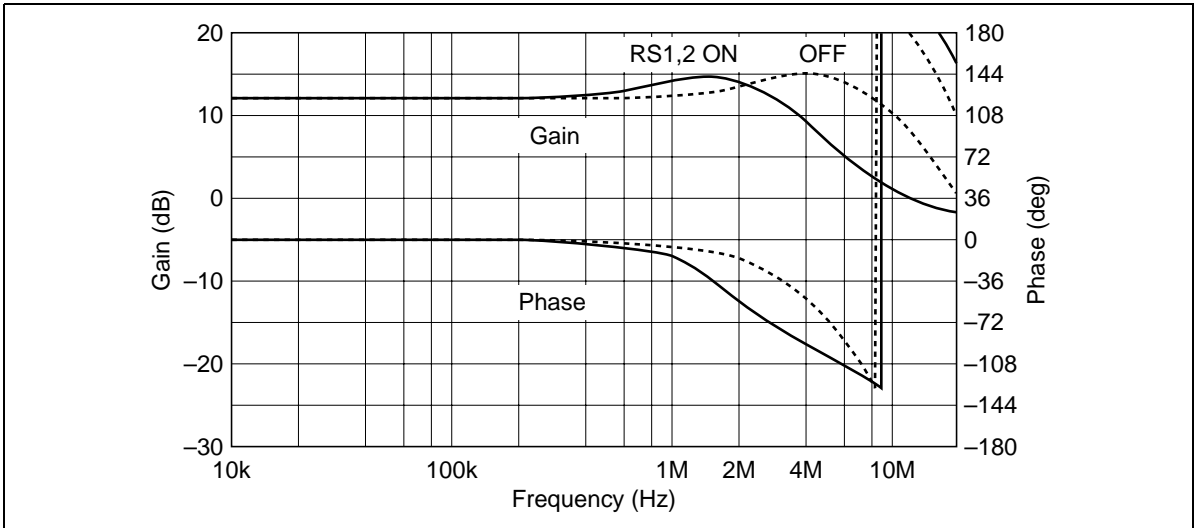

Figure 3-A Frequency characteristic example of RF preamplifiers

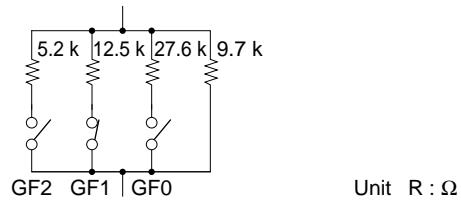

Figure 4 Focus VR

Table 3 Focus VR and Gain

D2	D1	D0	VR	Gain
0	1	0	9.7k	-4.8dB
0	1	1	7.2k	-2.2dB
0	0	0	5.5k	$\pm 0$ dB
0	0	1	4.6k	+1.6dB
1	1	0	3.4k	+3.8dB
1	1	1	3k	+4.9dB
1	0	0	2.7k	+6.0dB
1	0	1	2.4k	+6.8dB

## 3. Tracking Pre-Amplifiers

The sub-beam outputs from the photodiode IC are led in through resistors at pins 48 and 49.

External resistances of pins 48 and 49 and amplifier TE should be set according to the pick-up so that the traverse signal at pin 52 is about  $2 V_{pp}$ .

After a reset, the initial value of the feedback resistance BAL from amplifier TR1 to pin 48 is 400k $\Omega$ , the same as the feedback resistance from amplifier TR2 to pin 49.

BAL has a variable resistance value that is controlled by 4-bit data. The variable range is from -32% to +28% of the reset value. This resistance can be varied to adjust the EF balance of the tracking error.

Amplifier TE generates the tracking error signal. Its input signals are received from the preceding stage through variable resistors VR. With the external resistor values in figure 5, after a reset, the initial value of the gain is 8.8dB.

The variable VR resistance is controlled by 3-bit data. The gain can be varied from -5dB to +7dB with respect to the reset value.

The tracking error signal is coupled through a capacitor to input pin 53 and binarized by comparator TZC, with a  $V_{th}$  equal to  $V_c$ . (\*1)

Note: 1 At normal speed the output of amplifier TE contains much EFM signal components. Therefore the output of amplifier TE had better be led in through LPF for reduction of EFM signal components at pin 53.

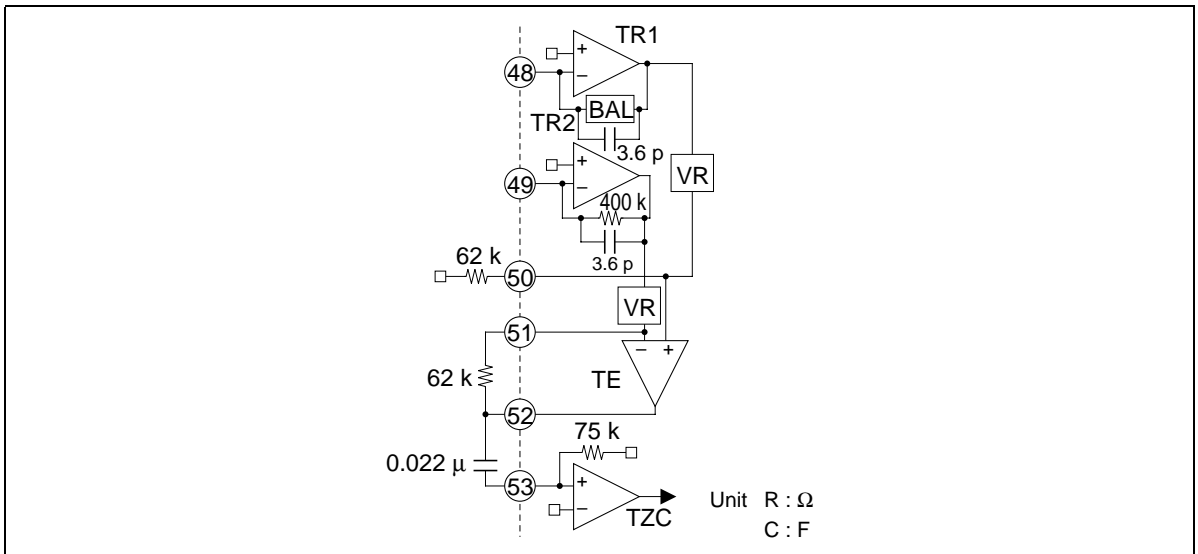

Figure 5 Tracking Pre-Amplifiers



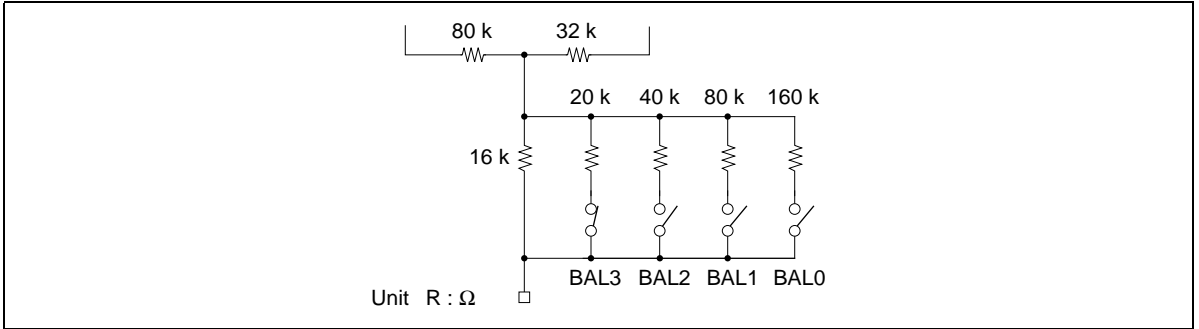

Figure 6 BAL

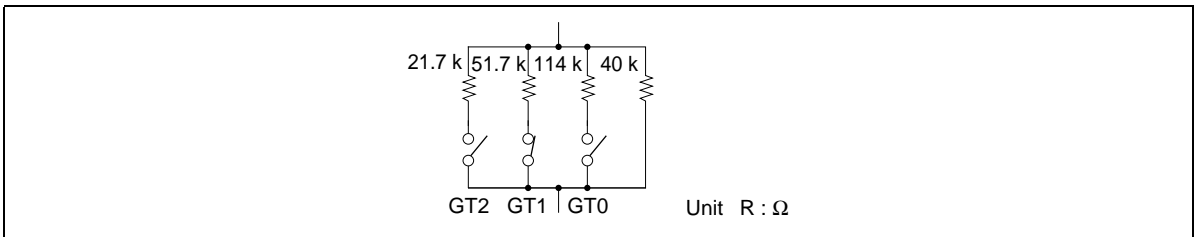

Figure 7 Tracking VR

Table 4 Tracking VR Values and Gain

D2	D1	D0	VR	Gain
0	1	0	40k	-4.9dB
0	1	1	29.6k	-2.3dB
0	0	0	22.6k	±0dB
0	0	1	18.8k	+1.6dB
1	1	0	14.1k	+3.9dB
1	1	1	12.5k	+4.9dB
1	0	0	11.1k	+6.1dB
1	0	1	10.1k	+6.9dB

# HA12188AF

**Table 5 BAL Values**

D3	D2	D1	D0	BAL	Ratio
1	0	0	0	272k	-32%
1	0	0	1	288k	-28%
1	0	1	0	304k	-24%
1	0	1	1	320k	-20%
1	1	0	0	336k	-16%
1	1	0	1	352k	-12%
1	1	1	0	368k	-8%
1	1	1	1	384k	-4%
0	0	0	0	400k	±0%
0	0	0	1	416k	+4%
0	0	1	0	432k	+8%
0	0	1	1	448k	+12%
0	1	0	0	464k	+16%
0	1	0	1	480k	+20%
0	1	1	0	496k	+24%
0	1	1	1	512k	+28%

## 4. FOK Detector

This detector is a comparator that generates the FOK signal. FOK is one of the signals that determines when to activate the focus servo. When the voltage at pin 38 exceeds the voltage at pin 34 by approximately 0.4V, pin 32 goes high.

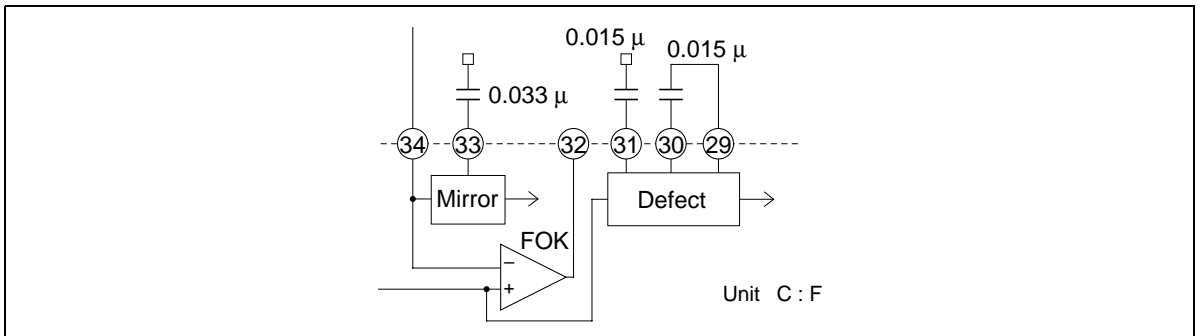

**Figure 8 Mirror, FOK, and Defect Detectors**

**5. Defect Detector**

When a scratched disc is played, the EFM RF signal has the shape shown in figure 9 (a). The defect detector detects the drop-out area of this signal. Scratches with dimensions of about 100µm or greater are detected.

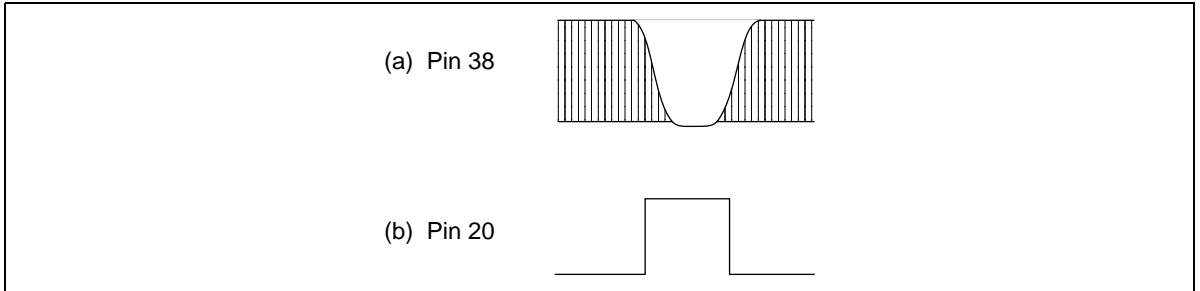
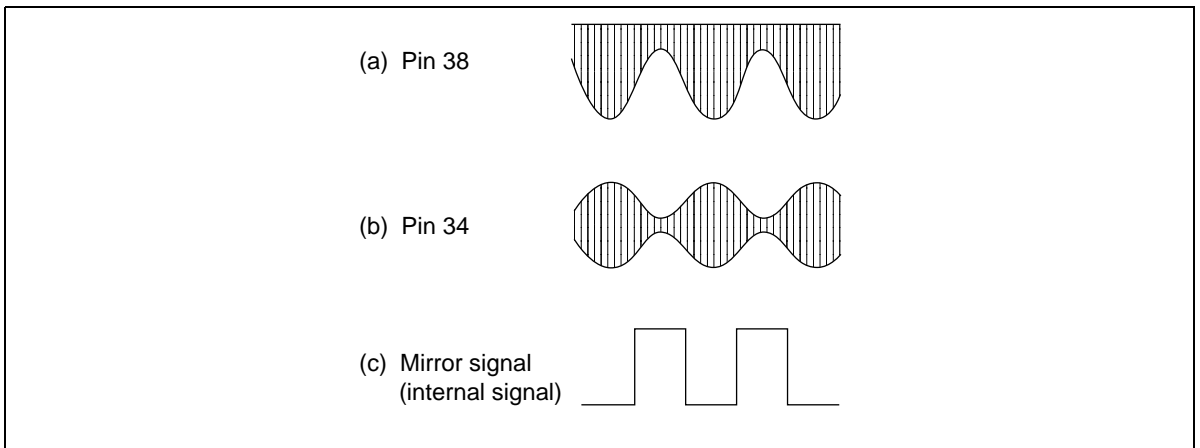

**Figure 9 Defect Detector Waveforms**

**6. Mirror Detector**

As the pick-up travels across tracks, the EFM RF signal varies as in figure 10 (a). At pin 34, the signal varies as in figure 10 (b). The mirror detector detects the mirror areas. The external capacitor on pin 33 integrates the track-crossing frequency component.

The internal time constant of the mirror detector can be set for normal, double, or quadruple speed by microprocessor commands, to raise the trackable range of track-crossing frequencies.



**Figure 10 Mirror Detector Waveforms**

# HA12188AF

## 7. Bias

The 12-k $\Omega$  external resistor on pin 36 sets the reference value of the IC's internal bias current. Use only this resistance value. The IC will not operate correctly with other resistance values.

Pin 35 is for a bypass capacitor to eliminate noise from the IC's internal bias circuits.

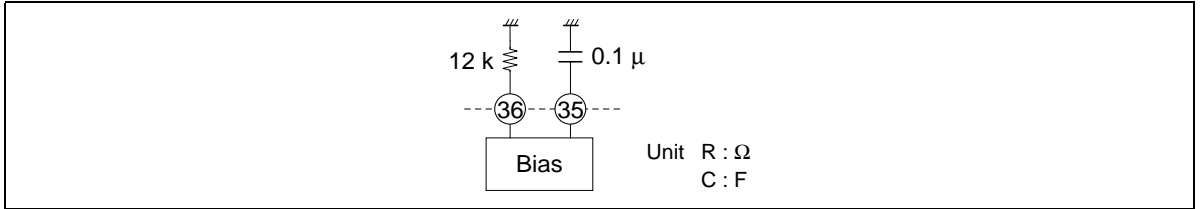

Figure 11 Bias

## 8. APC

This circuit is for the Psub laser diode. The APC circuit is switched off when pin 28 is high.

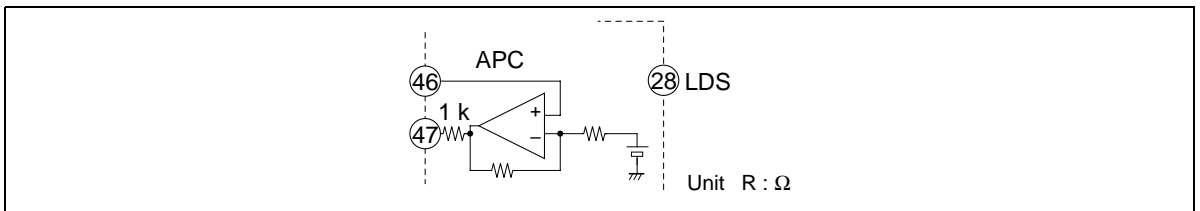

Figure 12 APC

## 9. Focus Servo System

The focus error signal is led in through a gain-control resistor to pin 56. Focus bias is adjusted at pin 56.

When a defect is detected, switch DS2 propagates the focus error signal, which is integrated by an internal resistor and external capacitor. Switch DS2 also inverts the phase of the propagated signal.

Switch FS4 is the focus servo loop switch.

Switch FLS switches low frequency filter, thereby switching the AC gain of the servo.

Switch FPS switches the peak phase-compensation frequency. This switch is linked with switch FLS and tracking servo switches TLS and TPS. For example this switch is off at normal, double speed and is on at quadruple speed.

The DC gain from input at pin 56 to output at pin 9 is 19dB. Figure 14 shows the frequency characteristic when pin 4, 5 are open.

Switch FS1 switches a current source to generate the focus search voltage. When switch FS2 is switched on, focus is acquired by switching switch FS1 on and off.

The current through switch FS1 can be switched in two stages: 36 $\mu$ A sink/18 $\mu$ A source, and 18 $\mu$ A sink/9 $\mu$ A source.

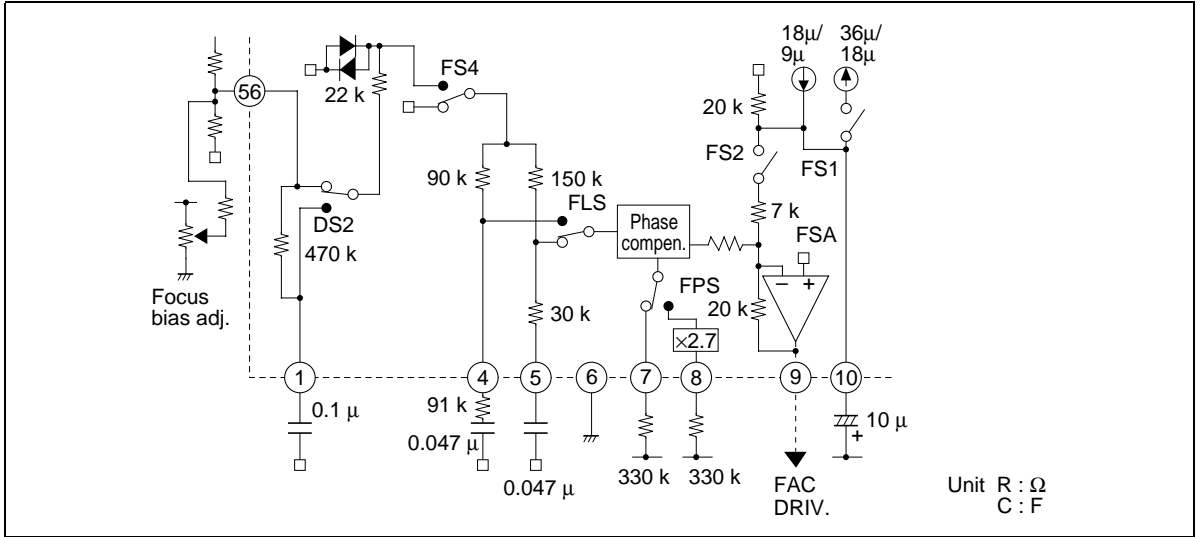

Figure 13 Focus Servo

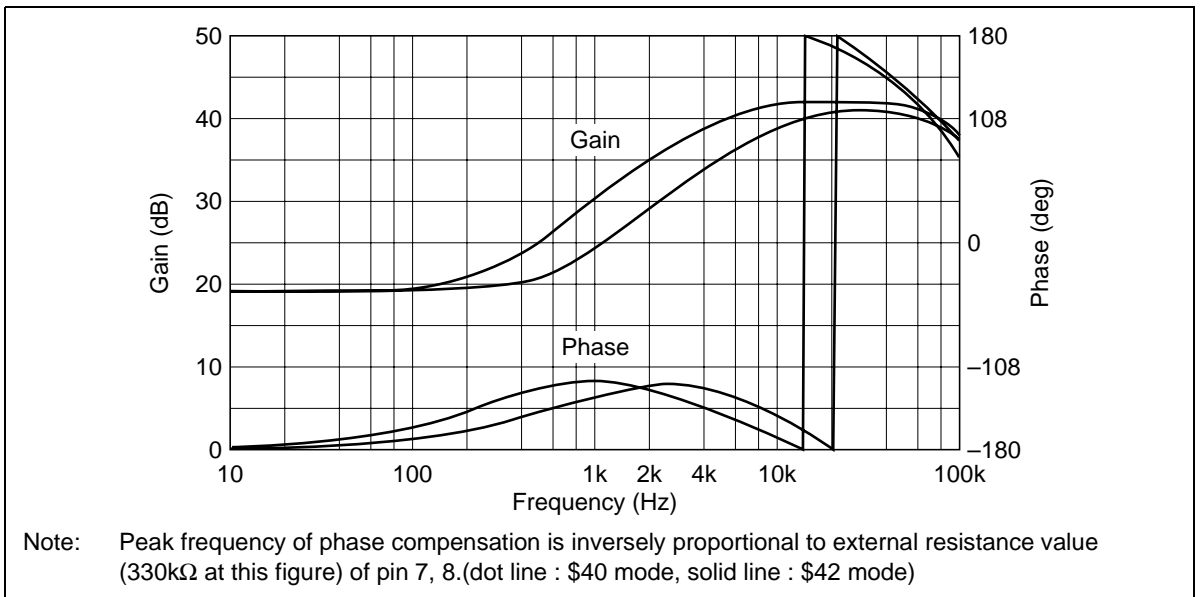

Figure 14 Focus Servo Frequency Characteristic (pin 4, 5 are open)

# HA12188AF

The transform function of phase compen block at figure 13 is as follows.

$$\frac{V_{OUT}}{V_{IN}} \approx \frac{8.95}{1+j\omega (2.7 \times 10^{-6})} \frac{1+j\omega \left( \frac{7.9 \times 10^{-9}}{I} \right)}{1+j\omega \left( \frac{5.6 \times 10^{-10}}{I} \right)}$$

$$\phi \approx \tan^{-1}\omega \left( \frac{7.9 \times 10^{-9}}{I} \right) - \tan^{-1}\omega \left( \frac{5.6 \times 10^{-10}}{I} \right) - \tan^{-1}\omega (2.7 \times 10^{-6})$$

at FPS OFF  $I = I_7$       at FPS ON  $I = 2.7 I_8$

$$I_7 \text{ or } I_8 \approx \frac{V_{CC} - 0.71V}{\text{External resistance value of pin 7 or 8}}$$

## 10. Tracking Servo System

The tracking error signal is led in through a gain-control resistor to pin 2.

When a defect is detected, switch DS1 propagates the tracking error signal, which is integrated by an internal resistor and external capacitor. Switch DS1 also inverts the phase of the propagated signal.

Switch TM1 is the tracking servo loop switch.

Switch TLS switches low frequency filter, thereby switching the AC gain of the servo.

The purpose of switch THS is to raise the high-frequency gain.

Switch TPS switches the peak phase-compensation frequency. This switch is linked with switch TLS and focus servo switches FLS and FPS. For example this switch is off at normal, double speed and is on at quadruple speed.

Switch TM7 is turned on by taking the logical AND of COUT and microprocessor data, to improve the performance of the pick-up. COUT is a signal generated by latching Mirror with both edges of TZC.

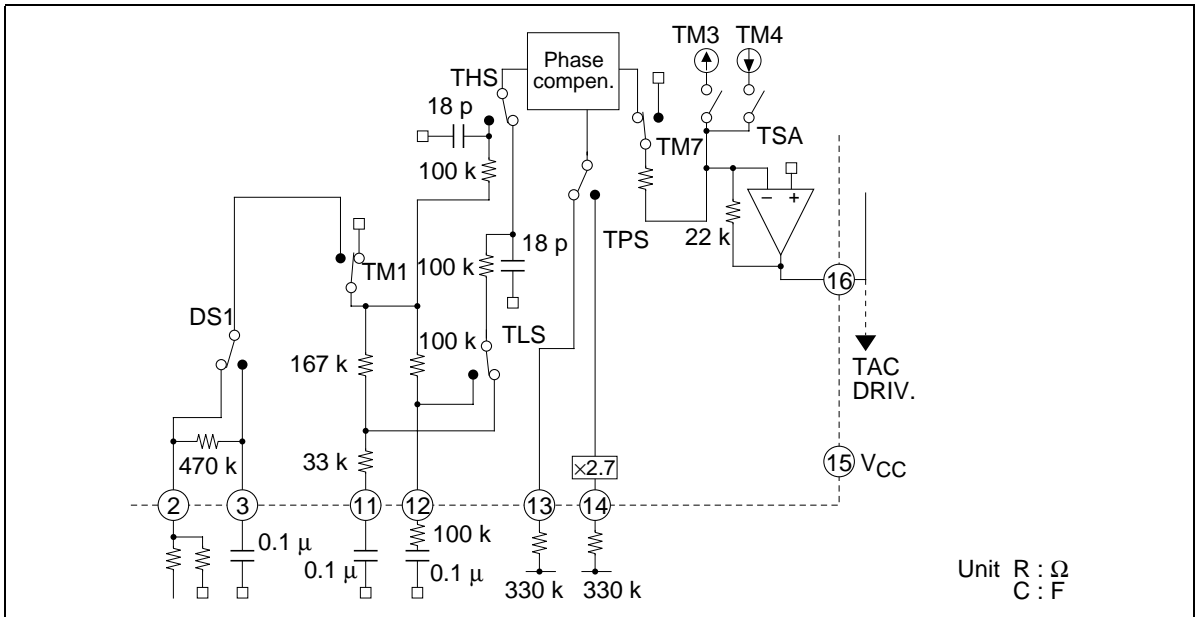
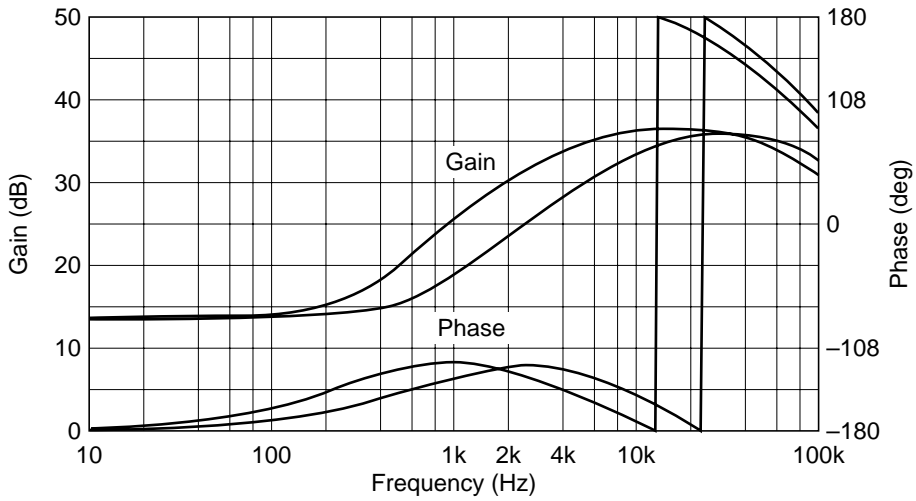

Figure 15 Tracking Servo



Note: Peak frequency of phase compensation is inversely proportional to external resistance value (330kΩ at this figure) of pin 13, 14. (dot line : \$40 mode, solid line : \$42 mode)

**Figure 16 Tracking Servo Frequency Characteristic (pin 11, 12 are open)**

The transform function of phase compen block at figure 15 is as follows.

$$\frac{V_{OUT}}{V_{IN}} \approx 4.47 \frac{1+j\omega \left( \frac{7.9 \times 10^{-9}}{|} \right)}{1+j\omega \left( \frac{5.6 \times 10^{-10}}{|} \right)}$$

$$\phi \approx \tan^{-1} \omega \left( \frac{7.9 \times 10^{-9}}{|} \right) - \tan^{-1} \omega \left( \frac{5.6 \times 10^{-10}}{|} \right)$$

at TPS OFF  $I = I_{13}$       at TPS ON  $I = 2.7 I_{14}$

$$I_{13} \text{ or } I_{14} \approx \frac{V_{CC} - 0.71V}{\text{External resistance value of pin 13 or 14}}$$

Figure 17 shows the phase relationships of Mirror, the tracking error, TZC, and COUT. TM7 operates to prevent the moving direction component of the tracking error signal from reaching the actuator.

The purpose of switches TM3 and TM4 is to generate the track jump voltage. A positive voltage appears at pin 16 when TM3 is switched on. A negative voltage appears at pin 16 when TM4 is switched on.

The current values through switches TM3 and TM4 can be selected in four steps:  $8\mu\text{A}$ ,  $16\mu\text{A}$ ,  $24\mu\text{A}$ , and  $32\mu\text{A}$ . The DC gain from input at pin 2 to output at pin 16 is 13dB. Figure 16 shows the frequency characteristic when pin 11, 12 are open.

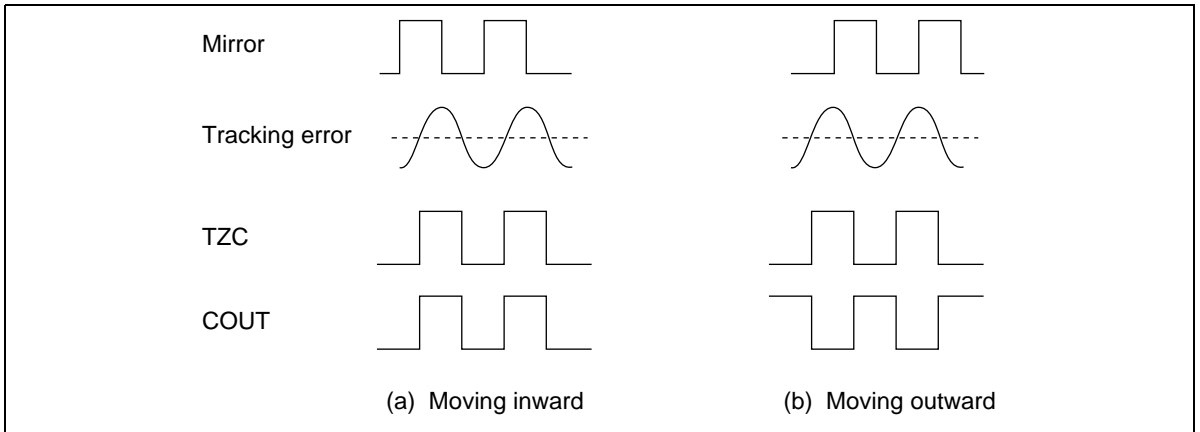

**Figure 17 Phase Relationships of Mirror and Other Signals**

## 11. DRT

DRT is an output signal that indicates the inward or outward direction. In the example in figure 18, DRT is low during motion from outer toward inner tracks, and high for motion in the reverse direction. This signal is output from pin 20 on command from the microprocessor.

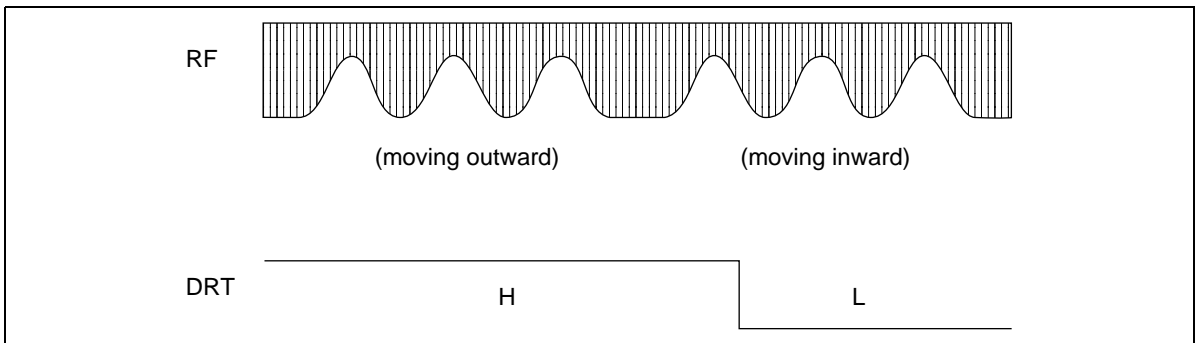

**Figure 18 DRT**



**12. Sled Servo**

The signal output at pin 16 is passed through a low-pass filter and input at pin 17. TM2 is the loop switch of the sled servo.

TM5 and TM6 are current switches that generate voltages for large movements of the sled. A positive voltage appears at pin 19 when TM5 is switched on. A negative voltage appears at pin 19 when TM6 is switched on.

The current values through switches TM5 and TM6 can be selected in four steps: 8 $\mu$ A, 16 $\mu$ A, 24 $\mu$ A, and 32 $\mu$ A.

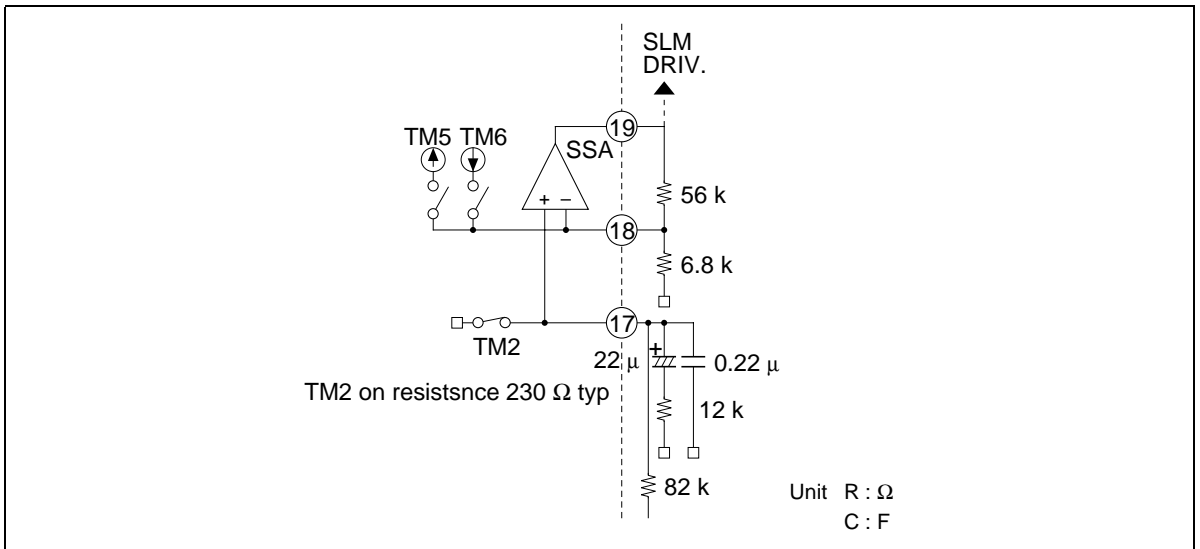

**Figure 19 Sled Servo**

**13. Direct Control**

The switches in the tracking control and sled servo control blocks can be switched on and off by microprocessor commands. TM1 to TM6 can also be controlled directly by the DC pin after input of serial data from the microprocessor.

When the microprocessor sends a command from \$20 to \$2F as serial data with DC high, TM1 to TM6 are placed in the states indicated under ST1 in table 2. Next, when DC is driven low, the states change to ST2. When DC is brought high again, the states change to ST3.

Example of using the DC terminal for 1 track jump is as follows.

For inside track jump, after sending the \$2C at DC = "H", when the TZC's rising edge is detected set DC = "L" and set DC = "H" after a setting time.

For outside track jump, after sending the \$28 at DC = "H", when the TZC's falling edge is detected, set DC = "L" and set DC = "H" after a setting time.



**Absolute Maximum Ratings**

<b>Item</b>	<b>Symbol</b>	<b>Value</b>	<b>Unit</b>
Power supply voltage	$V_{CC}$	7	V
Power dissipation	$P_T$	550	mW
Operating temperature	$T_{opr}$	-20 to +75	°C
Storage temperature	$T_{stg}$	-55 to +125	°C

Note: Recommended operating power supply voltage range:  $5 \pm 0.5V$ .

# HA12188AF

## Electrical Characteristics (Ta = 25°C, V<sub>CC</sub> = 5V)

Item	Symbol	Min	Typ	Max	Unit	Test Conditions	Pins	
1.Current dissipation	I <sub>CC</sub>	—	36	52	mA	No signal	15, 42	
2.Reference voltage	V <sub>C</sub>	2.3	2.5	2.7	V	I45 = ±5mA	45	
RF amp.	3.Offset voltage	V <sub>RF</sub>	-65	0	65	mV		38
	4.Max. output level H	V <sub>RFH</sub>	4.2	—	—	V	S38,S43,S44,S61 V61 = 4.0V	38
	5.Max. output level L	V <sub>RFL</sub>	—	—	2.1	V	S38,S43,S44,S61 V61 = 1.0V	38
	6.Voltage gain	G <sub>VRF</sub>	10.0	12.0	14.0	dB	S43, S44, S60 V38/V <sub>IN</sub> 60	38
Focus error amp.	7.Offset voltage	V <sub>FA</sub>	-65	0	65	mV		55
	8.Max. output level H	V <sub>FAH</sub>	4.0	4.5	—	V	S44, S55, S61 V61 = 4.0V	55
	9.Max. output level L	V <sub>FAL</sub>	—	0.5	1.0	V	S43, S55, S61 V61 = 4.0V	55
	10.Voltage gain 1	G <sub>VFA1</sub>	6.7	8.7	10.7	dB	S43, S60 V55/V <sub>IN</sub> 60	55
	11.Voltage gain 2	G <sub>VFA2</sub>	6.7	8.7	10.7	dB	S44, S60 V55/V <sub>IN</sub> 60	55
Tracking error amp.	12.Offset voltage	V <sub>TE</sub>	-50	0	50	mV		52
	13.Max. output level H	V <sub>TEH</sub>	4.0	4.5	—	V	S49, S52, S61 V61 = 4.0V	52
	14.Max. output level L	V <sub>TEL</sub>	—	0.5	1.0	V	S48, S52, S61 V61 = 4.0V	52
	15.Voltage gain 1	G <sub>VTE1</sub>	7.0	9.0	11.0	dB	S49, S60 V52/V <sub>IN</sub> 60	52
	16.Voltage gain 2	G <sub>VTE2</sub>	7.0	9.0	11.0	dB	S48, S60 V52/V <sub>IN</sub> 60	52
FOK	17.FOK Vth	V <sub>FOK</sub>	0.25	0.38	0.50	V	S34, S61 when V32 ≥ 4V Min (V38 - V34)	32
	18."H" output voltage	V <sub>FKH</sub>	4.7	—	—	V	S34, S61	32
	19."L" output voltage	V <sub>FKL</sub>	—	—	0.4	V	S32, S34, S61	32
Defect	20.Max operation frequency	F <sub>DH</sub>	2	—	—	kHz	S43, S44, S60	20
	21.Min operation frequency	F <sub>DL</sub>	—	—	1	kHz	S43, S44, S60	20
	22."H" output voltage	V <sub>DFH</sub>	4.7	—	—	V		20
	23."L" output voltage	V <sub>DFL</sub>	—	—	0.4	V	S20	20

Note: All offset voltages are values referring to V<sub>C</sub> (pin 45) at XRST = "L".

**Electrical Characteristics** ( $T_a = 25^\circ\text{C}$ ,  $V_{CC} = 5\text{V}$ ) (cont)

Item		Symbol	Min	Typ	Max	Unit	Test Conditions	Pins
Defect	24.Operation min input level	$V_{DF1}$	0.75	—	—	VPP	S43, S44, S60	20
	25.operation max input level	$V_{DF2}$	—	—	2.5	VPP	S43, S44, S60	20
COUT	26.Max operation frequency	$F_{CO}$	100	—	—	kHz	S34A, S53, S60 *1 Mirror Quadruple mode	21
	27."H" output voltage	$V_{COH}$	4.7	—	—	V		21
	28."L" output voltage	$V_{COL}$	—	—	0.4	V	S21	21
CLK, DATA, XLT, DC, XRST	29."H" input level	$V_{MH}$	4.0	—	—	V		23 to 27
	30."L" input level	$V_{ML}$	—	—	1.0	V		23 to 27
APC	31.APC voltage	$V_{APC}$	0.09	0.16	0.23	V		46
	32.TZC Vth	$V_{TZC}$	-40	0	40	mV	S53, S61 Refer to V53	53
	33.FZC Vth	$V_{FZC}$	0.25	0.38	0.50	V	S43, S61	55
Focus servo amp.	34.Offset voltage	$V_{FO}$	-100	0	100	mV		9
	35.Max output level H	$V_{FOH}$	4.0	4.5	—	V	S9, S56, S61 FS4 on, V61 = 1.0V	9
	36.Max output level L	$V_{FOL}$	—	0.8	1.0	V	S9, S56, S61 FS4 on, V61 = 4.0V	9
	37.Voltage gain	$G_{VFO}$	16.9	18.9	20.9	dB	S56, S60 V9/V <sub>IN</sub> 60 FS4, FLS, FPS on	9
	38.Search voltage 1	$V_{S1}$	-0.70	-0.51	-0.32	V	FS2 on V9 - V <sub>FO</sub> - V <sub>C</sub>	9
	39.Search voltage 2	$V_{S2}$	0.32	0.51	0.70	V	FS2, FS1 on V9 - V <sub>FO</sub> - V <sub>C</sub>	9
Tracking servo amp.	40.Offset voltage	$V_{TO}$	-120	0	120	mV		16
	41.Max output level H	$V_{TOH}$	4.0	4.5	—	V	S2, S16, S61 TM1 on, V61 = 1.0V	16
	42.Max output level L	$V_{TOL}$	—	0.8	1.0	V	S2, S16, S61 TM1 on, V61 = 4.0V	16

Note: 90deg phase difference between  $V_{IN}$  34 and  $V_{IN}$  60.

# HA12188AF

## Electrical Characteristics (Ta = 25°C, V<sub>CC</sub> = 5V) (cont)

Item		Symbol	Min	Typ	Max	Unit	Test Conditions	Pins
Tracking servo amp.	43.Voltage gain	G <sub>VTO</sub>	11.4	13.4	15.4	dB	S2, S60 TLS, TPS, TM1 on V16/V <sub>IN</sub> 60	16
	44.TM3 voltage	V <sub>TM3</sub>	0.51	0.71	0.89	V	TM3 on V16 - V <sub>TO</sub> - V <sub>C</sub>	16
	45.TM4 voltage	V <sub>TM4</sub>	-0.89	-0.71	-0.51	V	TM4 on V16 - V <sub>TO</sub> - V <sub>C</sub>	16
Sled servo amp.	46.Offset voltage	V <sub>SO</sub>	-66	0	66	mV		19
	47.Max output level H	V <sub>SOH</sub>	4.0	4.5	—	V	S17, S19, S61 TM2 on V61 = 4.0V	19
	48.Max output level L	V <sub>SOL</sub>	—	0.8	1.0	V	S17, S19, S61 TM2 on, V61 = 1.0V	19
	49.Voltage gain	G <sub>Vs</sub>	17.3	19.3	21.3	dB	S17, S60 TM2 on, V19/V <sub>IN</sub> 60	19
	50.TM5 voltage	V <sub>TM5</sub>	0.55	0.85	1.10	V	16μA mode TM5 on V19 - V <sub>so</sub> - V <sub>C</sub>	19
	51.TM6 voltage	V <sub>TM6</sub>	-1.10	-0.85	-0.55	V	16μA mode TM6 on V19 - V <sub>so</sub> - V <sub>C</sub>	19
SENS	52."H" output voltage	V <sub>SEH</sub>	4.7	—	—	V		22
	53."L" output voltage	V <sub>SEL</sub>	—	—	0.4	V	S22	22
LDS	54."H" input voltage	V <sub>LDH</sub>	3.5	—	—	V		28
	55."L" input voltage	V <sub>LDL</sub>	—	—	0.5	V		28
Focus VR	56.VR gain 1	G <sub>FVR1</sub>	-5.8	-4.8	-3.8	dB	S43, S60 V55 / V <sub>IN</sub> 60 - G <sub>VFA1</sub>	55
	57.VR gain 2	G <sub>FVR2</sub>	-3.2	-2.2	-1.2	dB	S43, S60 V55 / V <sub>IN</sub> 60 - G <sub>VFA1</sub>	55
	58.VR gain 3	G <sub>FVR3</sub>	2.8	3.8	4.8	dB	S43, S60 V55 / V <sub>IN</sub> 60 - G <sub>VFA1</sub>	55
	59.VR gain 4	G <sub>FVR4</sub>	5.8	6.8	7.8	dB	S43, S60 V55 / V <sub>IN</sub> 60 - G <sub>VFA1</sub>	55
Tracking VR	60.VR gain 1	G <sub>TVR1</sub>	-5.9	-4.9	-3.9	dB	S48, S60 V52 / V <sub>IN</sub> 60 - G <sub>VTE2</sub>	52
	61.VR gain 2	G <sub>TVR2</sub>	-3.3	-2.3	-1.3	dB	S48, S60 V52 / V <sub>IN</sub> 60 - G <sub>VTE2</sub>	52
	62.VR gain 3	G <sub>TVR3</sub>	2.9	3.9	4.9	dB	S48, S60 V52 / V <sub>IN</sub> 60 - G <sub>VTE2</sub>	52
	63.VR gain 4	G <sub>TVR4</sub>	5.9	6.9	7.9	dB	S48, S60 V52 / V <sub>IN</sub> 60 - G <sub>VTE2</sub>	52

**Electrical Characteristics** (Ta = 25°C, V<sub>CC</sub> = 5V) (cont)

Item		Symbol	Min	Typ	Max	Unit	Test Conditions	Pins
BAL	64.BAL gain 1	G <sub>BA1</sub>	-4.2	-3.2	-2.2	dB	S48, S60 V52/V <sub>IN,60</sub> - G <sub>VTE2</sub>	52
	65.BAL gain 2	G <sub>BA2</sub>	-3.7	-2.7	-1.7	dB	S48, S60 V52/V <sub>IN,60</sub> - G <sub>VTE2</sub>	52
	66.BAL gain 3	G <sub>BA3</sub>	-3.2	-2.2	-1.2	dB	S48, S60 V52/V <sub>IN,60</sub> - G <sub>VTE2</sub>	52
	67.BAL gain 4	G <sub>BA4</sub>	-2.4	-1.4	-0.4	dB	S48, S60 V52/V <sub>IN,60</sub> - G <sub>VTE2</sub>	52
	68.BAL gain 5	G <sub>BA5</sub>	1.1	2.1	3.1	dB	S48, S60 V52/V <sub>IN,60</sub> - G <sub>VTE2</sub>	52
Mirror	69.Operation min input level	V <sub>M1</sub>	0.25	—	—	V <sub>PP</sub>	S34A, S53, S60 Quadraple mode	21
	70.Operation max input level	V <sub>M2</sub>	—	—	2.5	V <sub>PP</sub>	S34A, S53, S60 Quadraple mode	21

**Test Method Notes**

Item No.	Notes
1	I15 (I15 means "current at pin 15". Following expressions are same as this expression.)+ I42
2	V45 (V45 means "voltage at pin 45". Following expressions are same as this expression. These symbols mean DC voltage at DC measuring and AC voltage at AC measuring.)
3	V38 - V <sub>C</sub>
4, 5	V38
6	20log (V38 / V <sub>IN,60</sub> ) V <sub>IN,60</sub> = 500kHz, 0.2 V <sub>PP</sub>
7	V55 - V <sub>C</sub>
8, 9	V55
10, 11	20log (V55 / V <sub>IN,60</sub> ) V <sub>IN,60</sub> = 4kHz, 0.5 V <sub>PP</sub>
12	V52 - V <sub>C</sub>
13, 14	V52
15, 16	20log (V52 / V <sub>IN,60</sub> ) V <sub>IN,60</sub> = 4kHz, 0.5 V <sub>PP</sub>
17	(V38 - V34) at the point that V32 exceeds 4V when V61 is lowered from 2.5V.
18, 19	V32
20	The maximum frequency for VIN60 such that the pin 20 signal is still a square wave. V <sub>IN,60</sub> = 0.25 V <sub>PP</sub> + V <sub>C</sub> + 95mV <sub>DC</sub>
21	The minimum frequency for VIN60 such that the pin 20 signal is still a square wave. V <sub>IN,60</sub> = 0.25 V <sub>PP</sub> + V <sub>C</sub> + 95mV <sub>DC</sub>
22, 23	V20

# HA12188AF

## Test Method Notes (cont)

Item No.	Notes
24	The minimum voltage for V38 such that the pin 20 signal is still a square wave. $V_{IN,60} = 1\text{kHz} + V_C + 95\text{mV}_{DC}$
25	The maximum voltage for V38 such that the pin 20 signal is still a square wave. $V_{IN,60} = 1\text{kHz} + V_C + 95\text{mV}_{DC}$
26	$V_{IN,60}, V_{IN,34}$ 90deg phase difference input signal $V_{IN,60} = V_{IN,34} = 1 V_{PP}$ The maximum frequency for $V_{IN,60}$ ( $V_{IN,34}$ ) such that the pin 21 signal is still a square wave.
27, 28	V21
29	H input voltage of pin 23 to 27
30	L input voltage of pin 23 to 27
31	V46
32	(V61 – V53) such that V22 exceeds 4V when V61 is upped from 2.4V. (SENS = TZC mode)
33	(V55 – $V_C$ ) such that V22 exceeds 4V when V61 is upped from 2.5V. (SENS = FZC mode)
34	$V9 - V_C$
35, 36	V9
37	$20\log(V9 / V_{IN,60})$ $V_{IN,60} = 1\text{kHz}, 0.15 V_{PP}$
38, 39	$V9 - VFO - V_C$
40	$V16 - V_C$
41, 42	V16
43	$20\log(V16 / V_{IN,60})$ $V_{IN,60} = 1\text{kHz}, 0.3 V_{PP}$
44, 45	$V9 - VTO - V_C$
46	$V19 - V_C$
47, 48	V19
49	$20\log(V19 / V_{IN,60})$ $V_{IN,60} = 4\text{kHz}, 0.15 V_{PP}$
50, 51	$V19 - VSO - V_C$
52, 53	V22
54	Input voltage of pin 28 such that APC is off.
55	Input voltage of pin 28 such that APC is on.
56	$GF2 = 0, \overline{GF1} = 1, GF0 = 0$ $20\log(V55 / V_{IN,60}) - G_{VFA1}$ $V_{IN,60} = 4\text{kHz}, 0.5 V_{PP}$
57	$GF2 = 0, \overline{GF1} = 1, GF0 = 1$ $20\log(V55 / V_{IN,60}) - G_{VFA1}$ $V_{IN,60} = 4\text{kHz}, 0.5 V_{PP}$
58	$GF2 = 1, \overline{GF1} = 1, GF0 = 0$ $20\log(V55 / V_{IN,60}) - G_{VFA1}$ $V_{IN,60} = 4\text{kHz}, 0.5 V_{PP}$
59	$GF2 = 1, \overline{GF1} = 0, GF0 = 1$ $20\log(V55 / V_{IN,60}) - G_{VFA1}$ $V_{IN,60} = 4\text{kHz}, 0.5 V_{PP}$
60	$GT2 = 0, \overline{GT1} = 1, GT0 = 0$ $20\log(V52 / V_{IN,60}) - G_{VTE2}$ $V_{IN,60} = 4\text{kHz}, 0.5 V_{PP}$
61	$GT2 = 0, \overline{GT1} = 1, GT0 = 1$ $20\log(V52 / V_{IN,60}) - G_{VTE2}$ $V_{IN,60} = 4\text{kHz}, 0.5 V_{PP}$
62	$GT2 = 1, \overline{GT1} = 1, GT0 = 0$ $20\log(V52 / V_{IN,60}) - G_{VTE2}$ $V_{IN,60} = 4\text{kHz}, 0.5 V_{PP}$
63	$GT2 = 1, \overline{GT1} = 0, GT0 = 1$ $20\log(V52 / V_{IN,60}) - G_{VTE2}$ $V_{IN,60} = 4\text{kHz}, 0.5 V_{PP}$



**Test Method Notes (cont)**

Item No.	Notes
64	$\overline{\text{BAL}}3 = 1, \text{BAL}2 = 0, \text{BAL}1 = 0, \text{BAL}0 = 0$ $20\log(V_{52} / V_{\text{IN}60}) - G_{\text{VTE}2}$ $V_{\text{IN}60} = 4\text{kHz}, 0.5V_{\text{PP}}$
65	$\overline{\text{BAL}}3 = 1, \text{BAL}2 = 0, \text{BAL}1 = 0, \text{BAL}0 = 1$ $20\log(V_{52} / V_{\text{IN}60}) - G_{\text{VTE}2}$ $V_{\text{IN}60} = 4\text{kHz}, 0.5V_{\text{PP}}$
66	$\overline{\text{BAL}}3 = 1, \text{BAL}2 = 0, \text{BAL}1 = 1, \text{BAL}0 = 0$ $20\log(V_{52} / V_{\text{IN}60}) - G_{\text{VTE}2}$ $V_{\text{IN}60} = 4\text{kHz}, 0.5V_{\text{PP}}$
67	$\overline{\text{BAL}}3 = 1, \text{BAL}2 = 1, \text{BAL}1 = 0, \text{BAL}0 = 0$ $20\log(V_{52} / V_{\text{IN}60}) - G_{\text{VTE}2}$ $V_{\text{IN}60} = 4\text{kHz}, 0.5V_{\text{PP}}$
68	$\overline{\text{BAL}}3 = 0, \text{BAL}2 = 1, \text{BAL}1 = 1, \text{BAL}0 = 1$ $20\log(V_{52} / V_{\text{IN}60}) - G_{\text{VTE}2}$ $V_{\text{IN}60} = 4\text{kHz}, 0.5V_{\text{PP}}$
69	The minimum input voltage for VIN34 such that the pin 21 signal is still a square wave. $V_{\text{IN}60} = 1\text{MHz}, 1 V_{\text{PP}}$ $V_{\text{IN}34} = 100\text{kHz}$
70	The maximum input voltage for VIN34 such that the pin 21 signal is still a square wave. $V_{\text{IN}60} = 1\text{MHz}, 1 V_{\text{PP}}$ $V_{\text{IN}34} = 100\text{kHz}$

# HA12188AF

## Package Dimensions

Unit: mm

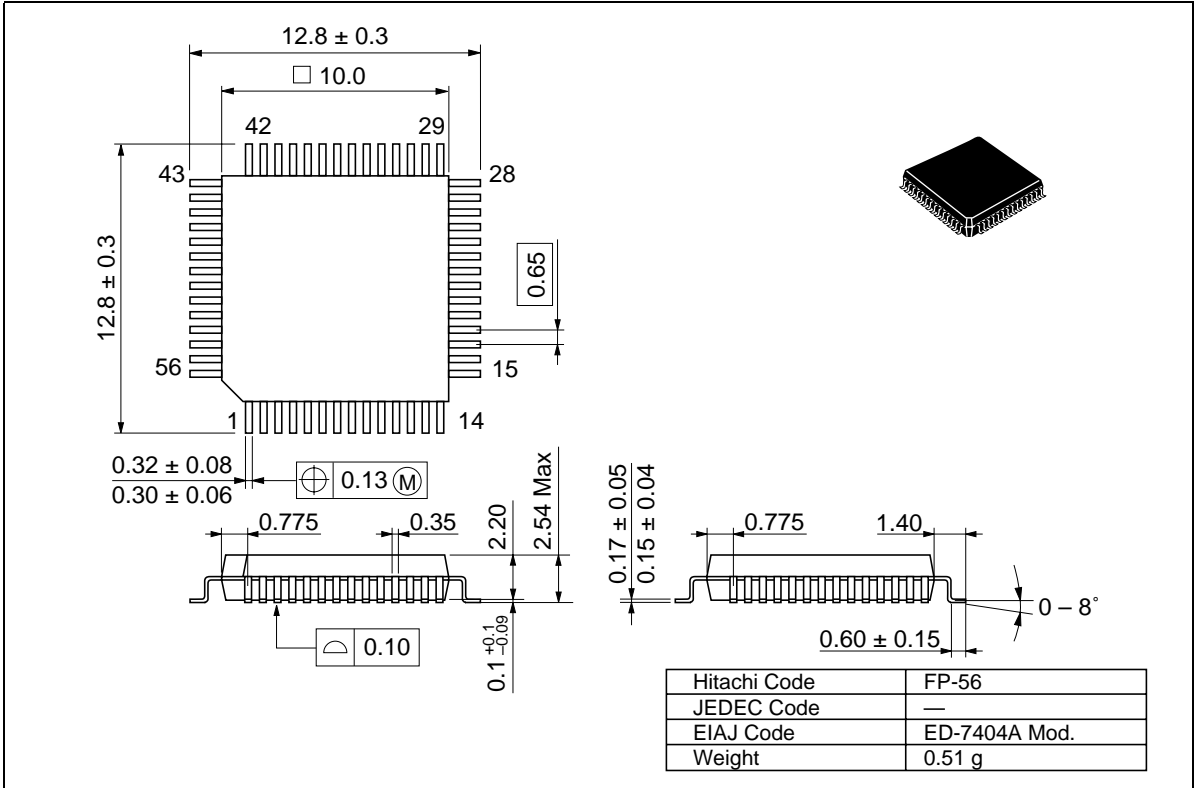

**Disclaimer**

1. Hitachi neither warrants nor grants licenses of any rights of Hitachi's or any third party's patent, copyright, trademark, or other intellectual property rights for information contained in this document. Hitachi bears no responsibility for problems that may arise with third party's rights, including intellectual property rights, in connection with use of the information contained in this document.
2. Products and product specifications may be subject to change without notice. Confirm that you have received the latest product standards or specifications before final design, purchase or use.
3. Hitachi makes every attempt to ensure that its products are of high quality and reliability. However, contact Hitachi's sales office before using the product in an application that demands especially high quality and reliability or where its failure or malfunction may directly threaten human life or cause risk of bodily injury, such as aerospace, aeronautics, nuclear power, combustion control, transportation, traffic, safety equipment or medical equipment for life support.
4. Design your application so that the product is used within the ranges guaranteed by Hitachi particularly for maximum rating, operating supply voltage range, heat radiation characteristics, installation conditions and other characteristics. Hitachi bears no responsibility for failure or damage when used beyond the guaranteed ranges. Even within the guaranteed ranges, consider normally foreseeable failure rates or failure modes in semiconductor devices and employ systemic measures such as fail-safes, so that the equipment incorporating Hitachi product does not cause bodily injury, fire or other consequential damage due to operation of the Hitachi product.
5. This product is not designed to be radiation resistant.
6. No one is permitted to reproduce or duplicate, in any form, the whole or part of this document without written approval from Hitachi.
7. Contact Hitachi's sales office for any questions regarding this document or Hitachi semiconductor products.

**Sales Offices**

**HITACHI**

**Hitachi, Ltd.**

Semiconductor & Integrated Circuits.  
 Nippon Bldg., 2-6-2, Ohte-machi, Chiyoda-ku, Tokyo 100-0004, Japan  
 Tel: Tokyo (03) 3270-2111 Fax: (03) 3270-5109

URL       NorthAmerica       : <http://semiconductor.hitachi.com/>  
           Europe                : <http://www.hitachi-eu.com/hel/ecg>  
           Asia                    : <http://sicapac.hitachi-asia.com>  
           Japan                   : <http://www.hitachi.co.jp/Sicd/indx.htm>

**For further information write to:**

Hitachi Semiconductor  
 (America) Inc.  
 179 East Tasman Drive,  
 San Jose, CA 95134  
 Tel: <1>(408) 433-1990  
 Fax: <1>(408) 433-0223

Hitachi Europe GmbH  
 Electronic Components Group  
 Dornacher Straße 3  
 D-85622 Feldkirchen, Munich  
 Germany  
 Tel: <49> (89) 9 9180-0  
 Fax: <49> (89) 9 29 30 00  
 Hitachi Europe Ltd.  
 Electronic Components Group.  
 Whitebrook Park  
 Lower Cookham Road  
 Maidenhead  
 Berkshire SL6 8YA, United Kingdom  
 Tel: <44> (1628) 585000  
 Fax: <44> (1628) 585160

Hitachi Asia Ltd.  
 Hitachi Tower  
 16 Collyer Quay #20-00,  
 Singapore 049318  
 Tel : <65>-538-6533/538-8577  
 Fax : <65>-538-6933/538-3877  
 URL : <http://www.hitachi.com.sg>

Hitachi Asia Ltd.  
 (Taipei Branch Office)  
 4/F, No. 167, Tun Hwa North Road,  
 Hung-Kuo Building,  
 Taipei (105), Taiwan  
 Tel : <886>-(2)-2718-3666  
 Fax : <886>-(2)-2718-8180  
 Telex : 23222 HAS-TP  
 URL : <http://www.hitachi.com.tw>

Hitachi Asia (Hong Kong) Ltd.  
 Group III (Electronic Components)  
 7/F., North Tower,  
 World Finance Centre,  
 Harbour City, Canton Road  
 Tsim Sha Tsui, Kowloon,  
 Hong Kong  
 Tel : <852>-(2)-735-9218  
 Fax : <852>-(2)-730-0281  
 URL : <http://www.hitachi.com.hk>

Copyright © Hitachi, Ltd., 2000. All rights reserved. Printed in Japan.  
 Colophon 2.0