

# Voltage Variable Absorptive Attenuator

## DC - 2 GHz

# AT-259

V 2.00

### Features

- Attenuation: 12 dB at 1 GHz
- Low Intermodulation Products
- Low DC Power Consumption: 50  $\mu$ W
- Single Voltage Control 0 to -4 Volts
- Nanosecond Switching Speed
- Temperature Range: -40°C to + 85°C
- Low Cost SOT/143 Plastic Package
- Tape and Reel Packaging Available<sup>1</sup>

### Description

M/A-COM's AT-259 is a GaAs MMIC voltage variable absorptive attenuator in a low cost SOT/143 4-Lead surface mount plastic package. The AT-259 is ideally suited for use where attenuation fine tuning, fast switching and very low power consumption are required. Typical applications include radio, cellular, GPS equipment and other Automatic Gain/Level Control circuits.

The AT-259 is fabricated with a monolithic GaAs MMIC using a mature 1 micron process. The process features full chip passivation for increased performance and reliability.

### SOT-143

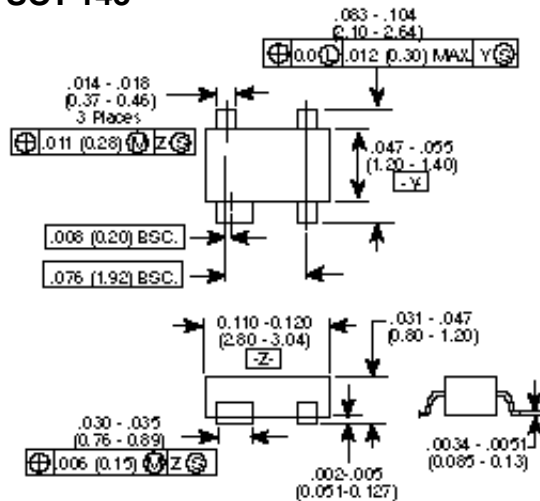

SOT-143 outline dimensions  
(All dimensions per JEDEC No. TO-253 Issue C)  
Dimensions in ( ) are in mm.  
Unless Otherwise Noted: \*\*\* =  $\pm 0.010$  ( \*\* =  $\pm 0.25$  )  
.\*\*\* =  $\pm 0.02$  (.# =  $\pm 0.5$  )

### Ordering Information

Part Number	Package
AT-259 PIN	SOT 4-Lead Plastic Package
AT-259TR	Forward Tape & Reel
AT-259RTR	Reverse Tape & Reel

### Electrical Specifications, $T_A = +25^\circ\text{C}$

Parameter	Test Conditions <sup>2</sup>	Unit	Min.	Typ.	Max
Insertion Loss	DC - 0.1 GHz	dB		2.9	3.1
		dB		3.0	3.2
		dB		3.2	3.5
		dB		3.4	3.8
Flatness (Peak to Peak)	DC - 2.0 GHz	5 dB Attenuation		$\pm 0.2$	$\pm 0.4$
		10 dB Attenuation		$\pm 2.3$	$\pm 2.5$
		15 dB Attenuation		$\pm 7.0$	$\pm 7.5$
VSWR			2.1:1		
Trise, Tfall Ton, Toff Transients	10% to 90% RF, 90% to 10% RF 50% Control to 90% RF, 50% Control to 10% RF In Band	nS		3	
		nS		5	
		mV		10	
Power Handling	Linear Operation	dBm			13
	Absolute Max. Input Power	dBm			21
IP <sub>2</sub>	Measured Relative to Input Power (For two-tone Input Power Up to +5 dBm)	0.05 GHz 0.5 - 2.0 GHz		34 47	
IP <sub>3</sub>	Measured Relative to Input Power (For two-tone Input Power Up to +5 dBm)	0.05 GHz 0.5 - 2.0 GHz	18 18.5	31 <sup>(3)</sup> 36 <sup>(3)</sup>	

1. Refer to "Tape and Reel Packaging" Section, or contact factory.  
2. All measurements at 1 GHz in a 50  $\Omega$  system, unless otherwise specified. A control voltage 0 to -4 volts @ 20  $\mu$ A typ.  
3. For levels above 6 dB attenuation. For levels below 6 dB, the minimum specification numbers apply.

### Absolute Maximum Ratings<sup>1</sup>

Parameter	Absolute Maximum
Max. Input Power	+21 dBm
Control Voltage	+5 V, -8.5 V
Operating Temperature	-40°C to +85°C
Storage Temperature	-65°C to +150°C

1.Operation of this device above any one of these parameters may cause permanent damage

### Pin Configuration

Pin No.	Description
1	GND
2	A
3	RF2
4	RF1

### Functional Schematic

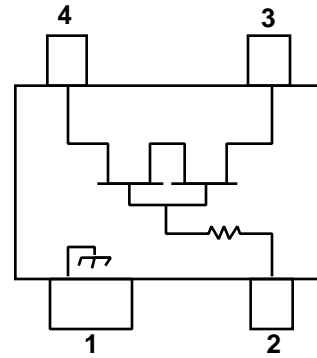

### Typical Performance

