



TS4B01G THRU TS4B07G

Single Phase 4.0 AMPS. Glass Passivated Bridge Rectifiers



Voltage Range
50 to 1000 Volts
Current
4.0 Amperes

Features

- ✧ UL Recognized File # E-96005
- ✧ Glass passivated junction
- ✧ Ideal for printed circuit board
- ✧ Reliable low cost construction
- ✧ Plastic material has Underwriters Laboratory Flammability Classification 94V-0
- ✧ Surge overload rating to 120 amperes peak
- ✧ High case dielectric strength of 2000V_{RMS}
- ✧ Case: Molded plastic
- ✧ Weight: 0.15 ounce, 4 grams
- ✧ Mounting torque: 5 in. lbs. Max.

TS4B

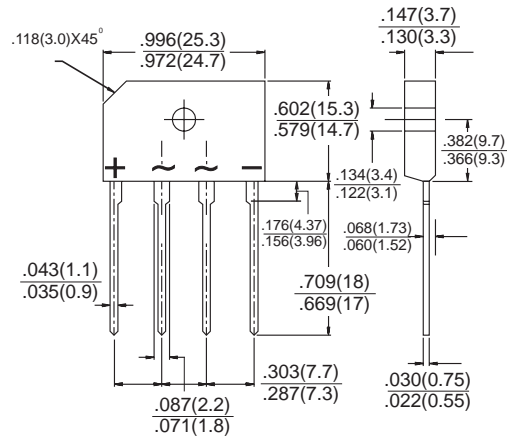

Maximum Ratings and Electrical Characteristics

Rating at 25°C ambient temperature unless otherwise specified.

Single phase, half wave, 60 Hz, resistive or inductive load.

For capacitive load, derate current by 20%

Type Number	Symbol	TS4B 01G	TS4B 02G	TS4B 03G	TS4B 04G	TS4B 05G	TS4B 06G	TS4B 07G	Units
Maximum Recurrent Peak Reverse Voltage	V _{RRM}	50	100	200	400	600	800	1000	V
Maximum RMS Voltage	V _{RMS}	35	70	140	280	420	560	700	V
Maximum DC Blocking Voltage	V _{DC}	50	100	200	400	600	800	1000	V
Maximum Average Forward Rectified Current @ T _C = 115°C	I _(AV)	4.0							A
Peak Forward Surge Current, 8.3 ms Single Half Sine-wave Superimposed on Rated Load (JEDEC method)	I _{FSM}	120							A
Maximum Instantaneous Forward Voltage @ 4.0A	V _F	1.0							V
Maximum DC Reverse Current @ T _A =25°C at Rated DC Blocking Voltage @ T _A =125°C	I _R	5.0							µA
		500							µA
Typical Thermal Resistance (Note)	R _{θJC}	5.5							°C/W
Operating Temperature Range	T _J	-55 to +150							°C
Storage Temperature Range	T _{STG}	-55 to +150							°C

Note: Thermal Resistance from Junction to Case with Device Mounted on 2" x 3" x 0.25" Al-Plate Heatsink.

RATINGS AND CHARACTERISTIC CURVES (TS4B01G THRU TS4B07G)

FIG.1- MAXIMUM NON-REPETITIVE FORWARD SURGE CURRENT PER BRIDGE ELEMENT

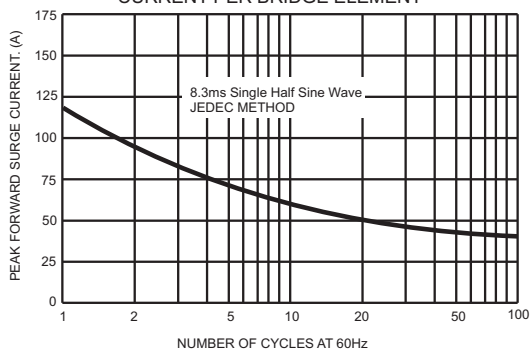

FIG.2- MAXIMUM FORWARD CURRENT DERATING CURVE PER BRIDGE ELEMENT

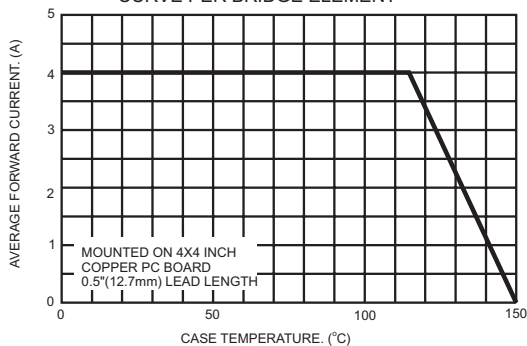

FIG.3- TYPICAL INSTANTANEOUS FORWARD CHARACTERISTICS PER BRIDGE ELEMENT

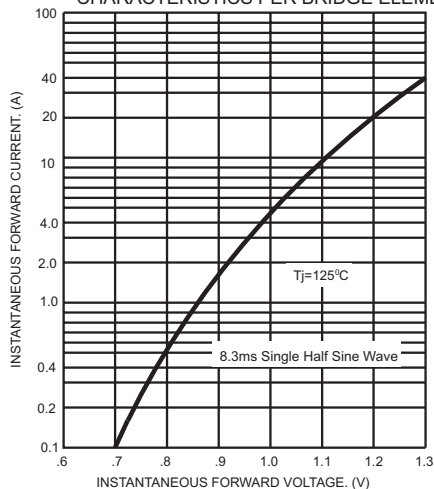

FIG.4- TYPICAL REVERSE CHARACTERISTICS PER BRIDGE ELEMENT

