

---

# HM534253B Series

262,144-word × 4-bit Multiport CMOS Video RAM

# HITACHI

ADE-203-204C (Z)

Rev. 3.0

Apr. 24, 1995

---

## Description

The HM534253B is a 1-Mbit multiport video RAM equipped with a 256-kword × 4-bit dynamic RAM and a 512-word × 4-bit SAM (serial access memory). Its RAM and SAM operate independently and asynchronously. It can transfer data between RAM and SAM. In addition, it has two modes to realize fast writing in RAM. Block write and flash write modes clear the data of 4-word × 4-bit and the data of one row (512-word × 4-bit) respectively in one cycle of RAM. And the HM534253B makes split transfer cycle possible by dividing SAM into two split buffers equipped with 256-word × 4-bit each. This cycle can transfer data to SAM which is not active, and enables a continuous serial access.

## Features

- Multiport organization
  - Asynchronous and simultaneous operation of RAM and SAM capability
  - RAM: 256-kword × 4-bit
  - SAM: 512-word × 4-bit
- Access time
  - RAM: 60 ns/70 ns/80 ns/100 ns max
  - SAM: 20 ns/22 ns/25 ns/25 ns max
- Cycle time
  - RAM: 125 ns/135 ns/150 ns/180 ns min
  - SAM: 25 ns/25 ns/30 ns/30 ns min
- Low power
  - Active    RAM: 413 mW max
  - SAM: 275 mW max
  - Standby    38.5 mW max
- High-speed page mode capability
- Mask write mode capability
- Bidirectional data transfer cycle between RAM and SAM capability
- Split transfer cycle capability
- Block write mode capability
- Flash write mode capability

# HM534253B Series

- 3 variations of refresh (8 ms/512 cycles)
  - $\overline{\text{RAS}}$ -only refresh
  - $\overline{\text{CAS}}$ -before- $\overline{\text{RAS}}$  refresh
  - Hidden refresh
- TTL compatible

## Ordering Information

Type No.	Access Time	Package
HM534253BJ-6	60 ns	400-mil 28-pin plastic SOJ (CP-28D)
HM534253BJ-7	70 ns	
HM534253BJ-8	80 ns	
HM534253BJ-10	100 ns	
HM534253BZ-6	60 ns	400-mil 28-pin plastic ZIP (ZP-28)
HM534253BZ-7	70 ns	
HM534253BZ-8	80 ns	
HM534253BZ-10	100 ns	

## Pin Arrangement

HM534253BJ Series

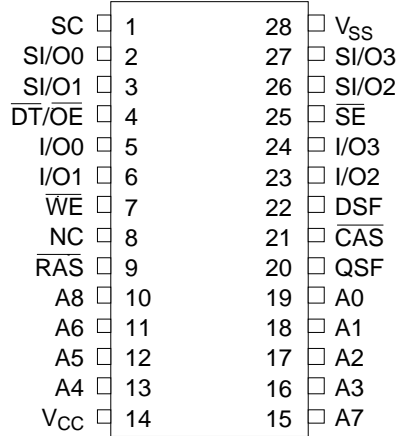

(Top View)

HM534253BZ Series

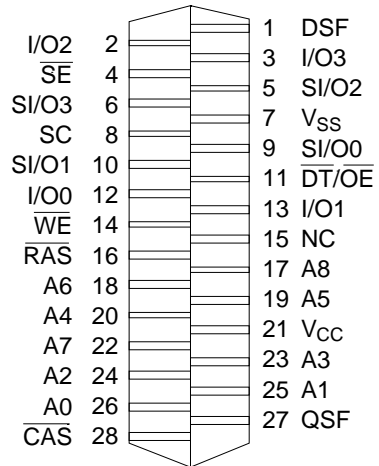

(Bottom View)

## Pin Description

<b>Pin Name</b>	<b>Function</b>
A0 – A8	Address inputs
I/O0 – I/O3	RAM port data inputs/outputs
SI/O0 – SI/O3	SAM port data inputs/outputs
$\overline{\text{RAS}}$	Row address strobe
$\overline{\text{CAS}}$	Column address strobe
$\overline{\text{WE}}$	Write enable
$\overline{\text{DT/OE}}$	Data transfer/output enable
SC	Serial clock
$\overline{\text{SE}}$	SAM port enable
DSF	Special function input flag
QSF	Special function output flag
$V_{\text{CC}}$	Power supply
$V_{\text{SS}}$	Ground
NC	No connection

## Block Diagram

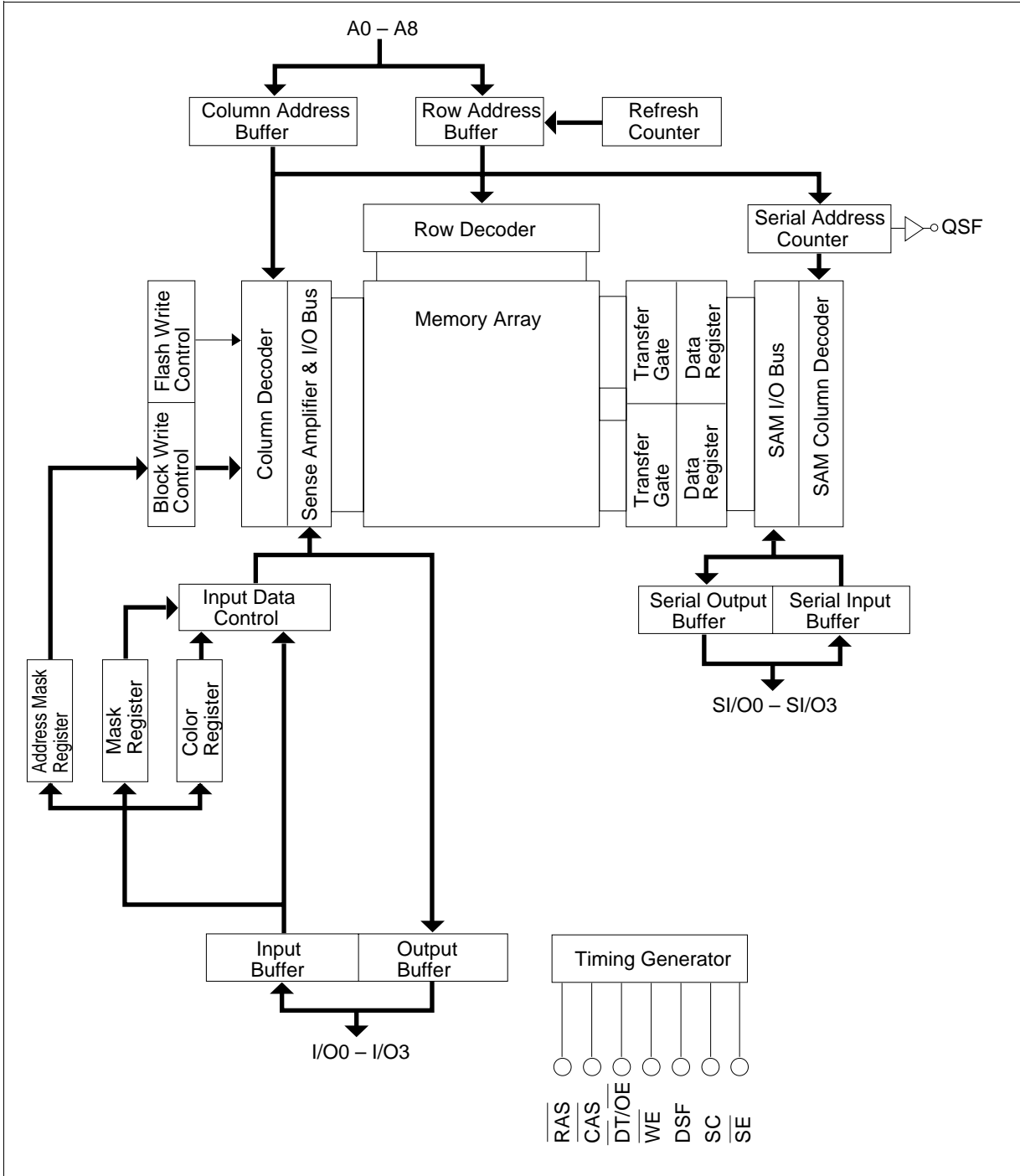

**Pin Functions**

**$\overline{\text{RAS}}$  (input pin):**  $\overline{\text{RAS}}$  is a basic RAM signal. It is active in low level and standby in high level. Row address and signals as shown in table 1 are input at the falling edge of  $\overline{\text{RAS}}$ . The input level of these signals determine the operation cycle of the HM534253B.

**Table 1 Operation Cycles of the HM534253B**

**Input Level At The Falling Edge Of  $\overline{\text{RAS}}$**

$\overline{\text{CAS}}$	$\overline{\text{DT/OE}}$	$\overline{\text{WE}}$	$\overline{\text{SE}}$	DSF	DSF At The Falling Edge Of $\overline{\text{CAS}}$	Operation Mode
L	X	X	X	X	—	CBR refresh
H	L	L	L	L	X	Write transfer
H	L	L	H	L	X	Pseudo transfer
H	L	L	X	H	X	Split write transfer
H	L	H	X	L	X	Read transfer
H	L	H	X	H	X	Split read transfer
H	H	L	X	L	L	Read/mask write
H	H	L	X	L	H	Mask block write
H	H	L	X	H	X	Flash write
H	H	H	X	L	L	Read/write
H	H	H	X	L	H	Block write
H	H	H	X	H	X	Color register read/write

Note: X: H or L.

**$\overline{\text{CAS}}$  (input pin):** Column address and DSF signals are fetched into chip at the falling edge of  $\overline{\text{CAS}}$ , which determines the operation mode of the HM534253B.  $\overline{\text{CAS}}$  controls output impedance of I/O in RAM.

**A0 – A8 (input pins):** Row address is determined by A0 – A8 level at the falling edge of  $\overline{\text{RAS}}$ . Column address is determined by A0 – A8 level at the falling edge of  $\overline{\text{CAS}}$ . In transfer cycles, row address is the address on the word line which transfers data with SAM data register, and column address is the SAM start address after transfer.

**$\overline{\text{WE}}$  (input pin):**  $\overline{\text{WE}}$  pin has two functions at the falling edge of  $\overline{\text{RAS}}$  and after. When  $\overline{\text{WE}}$  is low at the falling edge of  $\overline{\text{RAS}}$ , the HM534253B turns to mask write mode. According to the I/O level at the time, write on each I/O can be masked. ( $\overline{\text{WE}}$  level at the falling edge of  $\overline{\text{RAS}}$  is don't care in read cycle.) When  $\overline{\text{WE}}$  is high at the falling edge of  $\overline{\text{RAS}}$ , a normal write cycle is executed. After that,  $\overline{\text{WE}}$  switches read/write cycles as in a standard DRAM. In a transfer cycle, the direction of transfer is determined by  $\overline{\text{WE}}$  level at the falling edge of  $\overline{\text{RAS}}$ . When  $\overline{\text{WE}}$  is low, data is transferred from SAM to RAM (data is written into RAM), and when  $\overline{\text{WE}}$  is high, data is transferred from RAM to SAM (data is read from RAM).

---

## HM534253B Series

---

**I/O0 – I/O3 (input/output pins):** I/O pins function as mask data at the falling edge of  $\overline{\text{RAS}}$  (in mask write mode). Data is written only to high I/O pins. Data on low I/O pins are masked and internal data are retained. After that, they function as input/output pins as those of a standard DRAM. In block write cycle, they function as address mask data at the falling edges of  $\overline{\text{CAS}}$ .

**$\overline{\text{DT/OE}}$  (input pin):**  $\overline{\text{DT/OE}}$  pin functions as  $\overline{\text{DT}}$  (data transfer) pin at the falling edge of  $\overline{\text{RAS}}$  and as  $\overline{\text{OE}}$  (output enable) pin after that. When  $\overline{\text{DT}}$  is low at the falling edge of  $\overline{\text{RAS}}$ , this cycle becomes a transfer cycle. When  $\overline{\text{DT}}$  is high at the falling edge of  $\overline{\text{RAS}}$ , RAM and SAM operate independently.

**SC (input pin):** SC is a basic SAM clock. In a serial read cycle, data outputs from an SI/O pin synchronously with the rising edge of SC. In a serial write cycle, data on an SI/O pin at the rising edge of SC is fetched into the SAM data register.

**$\overline{\text{SE}}$ (input pin):**  $\overline{\text{SE}}$  pin activates SAM. When  $\overline{\text{SE}}$  is high, SI/O is in the high impedance state in serial read cycle and data on SI/O is not fetched into the SAM data register in serial write cycle.  $\overline{\text{SE}}$  can be used as a mask for serial write because internal pointer is incremented at the rising edge of SC.

**SI/O0 – SI/O3 (input/output pins):** SI/Os are input/output pins in SAM. Direction of input/output is determined by the previous transfer cycle. When it was a read transfer cycle, SI/O outputs data. When it was a pseudo transfer cycle or write transfer cycle, SI/O inputs data.

**DSF (input pin):** DSF is a special function data input flag pin. It is set to high at the falling edge of  $\overline{\text{RAS}}$  when new functions such as color register read/write, split transfer, and flash write, are used. DSF is set to high at the falling edge of  $\overline{\text{CAS}}$  when block write is executed.

**QSF (output pin):** QSF outputs data of address A8 in SAM. QSF is switched from low to high by accessing address 255 in SAM and from high to low by accessing 511 address in SAM.

## Operation of HM534253B

### RAM Port Operation

**RAM Read Cycle** ( $\overline{DT/OE}$  high,  $\overline{CAS}$  high and DSF low at the falling edge of  $\overline{RAS}$ , DSF low at the falling edge of  $\overline{CAS}$ )

Row address is entered at the  $\overline{RAS}$  falling edge and column address at the  $\overline{CAS}$  falling edge to the device as in standard DRAM. Then, when  $\overline{WE}$  is high and  $\overline{DT/OE}$  is low while  $\overline{CAS}$  is low, the selected address data outputs through I/O pin. At the falling edge of  $\overline{RAS}$ ,  $\overline{DT/OE}$  and  $\overline{CAS}$  become high to distinguish RAM read cycle from transfer cycle and CBR refresh cycle. Address access time ( $t_{AA}$ ) and  $\overline{RAS}$  to column address delay time ( $t_{RAD}$ ) specifications are added to enable high-speed page mode.

**RAM Write Cycle (Early Write, Delayed Write, Read-Modify-Write)** ( $\overline{DT/OE}$  high,  $\overline{CAS}$  high and DSF low at the falling edge of  $\overline{RAS}$ , DSF low at the falling edge of  $\overline{CAS}$ )

- Normal Mode Write Cycle ( $\overline{WE}$  high at the falling edge of  $\overline{RAS}$ )

When  $\overline{CAS}$  and  $\overline{WE}$  are set low after driving  $\overline{RAS}$  low, a write cycle is executed and I/O data is written in the selected addresses. When all 4 I/Os are written,  $\overline{WE}$  should be high at the falling edge of  $\overline{RAS}$  to distinguish normal mode from mask write mode.

If  $\overline{WE}$  is set low before the  $\overline{CAS}$  falling edge, this cycle becomes an early write cycle and all I/O become in high impedance. Data is entered at the  $\overline{CAS}$  falling edge.

If  $\overline{WE}$  is set low after the  $\overline{CAS}$  falling edge, this cycle becomes a delayed write cycle. Data is input at the  $\overline{WE}$  falling. I/O does not become high impedance in this cycle, so data should be entered with  $\overline{OE}$  in high.

If  $\overline{WE}$  is set low after  $t_{CWD}$  (min) and  $t_{AWD}$  (min) after the  $\overline{CAS}$  falling edge, this cycle becomes a read-modify-write cycle and enables read/write at the same address in one cycle. In this cycle also, to avoid I/O contention, data should be input after reading data and driving  $\overline{OE}$  high.

- Mask Write Mode ( $\overline{WE}$  low at the falling edge of  $\overline{RAS}$ )

If  $\overline{WE}$  is set low at the falling edge of  $\overline{RAS}$ , the cycle becomes a mask write mode which writes only to selected I/O. Whether or not an I/O is written depends on I/O level (mask data) at the falling edge of  $\overline{RAS}$ . Then the data is written in high I/O pins and masked in low ones and internal data is retained. This mask data is effective during the  $\overline{RAS}$  cycle. So, in high-speed page mode, the mask data is retained during the page access.

---

## HM534253B Series

---

**High-Speed Page Mode Cycle** ( $\overline{DT/OE}$  high,  $\overline{CAS}$  high and DSF low at the falling edge of  $\overline{RAS}$ )

High-speed page mode cycle reads/writes the data of the same row address at high speed by toggling  $\overline{CAS}$  while  $\overline{RAS}$  is low. Its cycle time is one third of the random read/write cycle. In this cycle, read, write, and block write cycles can be mixed. Note that address access time ( $t_{AA}$ ),  $\overline{RAS}$  to column address delay time ( $t_{RAD}$ ), and access time from  $\overline{CAS}$  precharge ( $t_{ACP}$ ) are added. In one  $\overline{RAS}$  cycle, 512-word memory cells of the same row address can be accessed. It is necessary to specify access frequency within  $t_{RASP}$  max (100  $\mu$ s).

**Color Register Set/Read Cycle** ( $\overline{CAS}$  high,  $\overline{DT/OE}$  high,  $\overline{WE}$  high and DSF high at the falling edge of  $\overline{RAS}$ )

In color register set cycle, color data is set to the internal color register used in flash write cycle or block write cycle. 4 bits of internal color register are provided at each I/O. This register is composed of static circuits, so once it is set, it retains the data until reset. Color register set cycle is just as same as the usual write cycle except that DSF is set high at the falling edge of  $\overline{RAS}$ , and read, early write and delayed write cycle can be executed. In this cycle, the HM534253B refreshes the row address fetched at the falling edge of  $\overline{RAS}$ .

**Flash Write Cycle** ( $\overline{CAS}$  high,  $\overline{DT/OE}$  high,  $\overline{WE}$  low, and DSF high at the falling edge of  $\overline{RAS}$ )

In a flash write cycle, a row of data (512-word  $\times$  4-bit) is cleared to 0 or 1 at each I/O according to the data of color register mentioned before. It is also necessary to mask I/O in this cycle. When  $\overline{CAS}$  and  $\overline{DT/OE}$  is set high,  $\overline{WE}$  is low, and DSF is high at the falling edge of  $\overline{RAS}$ , this cycle starts. Then, the row address to clear is given to row address and mask data is given to I/O. Mask data is as same as that of a RAM write cycle. High I/O is cleared, low I/O is not cleared and the internal data is retained. Cycle time is the same as those of RAM read/write cycles, so all bits can be cleared in 1/512 of the usual cycle time. (See figure 1.)



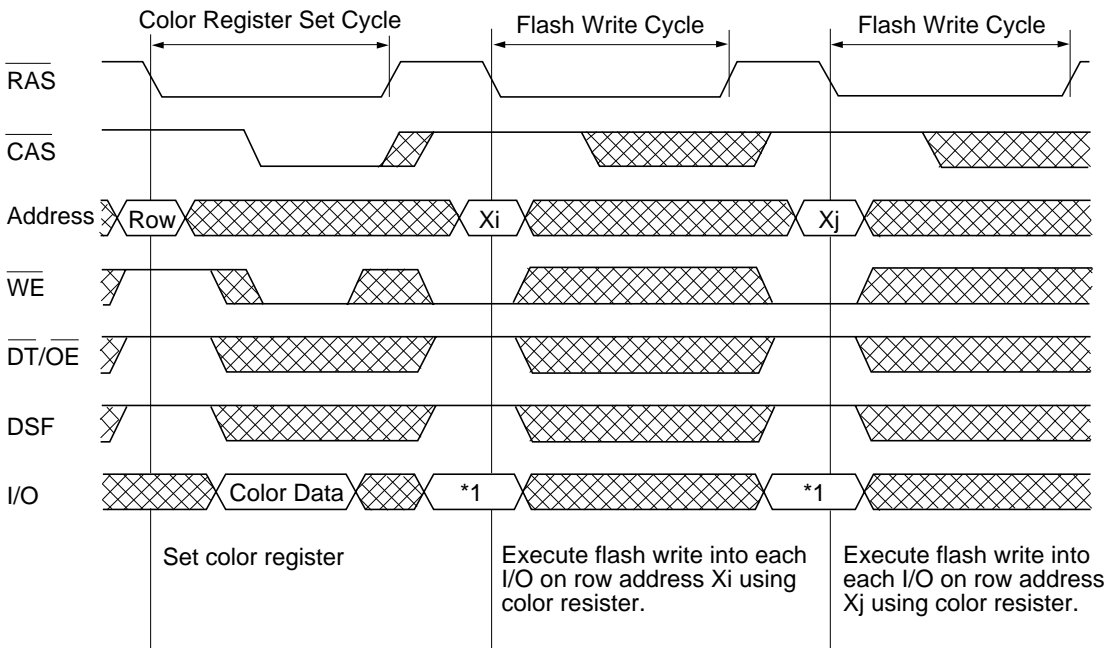

Note: 1. I/O Mask Data  
 Low: Mask  
 High: Non Mask

Figure 1 Use of Flash Write

**Block Write Cycle** ( $\overline{\text{CAS}}$  high,  $\overline{\text{DT/OE}}$  high and DSF low at the falling edge of  $\overline{\text{RAS}}$ , DSF high at the falling edge of  $\overline{\text{CAS}}$ )

In a block write cycle, 4 columns of data (4-word  $\times$  4-bit) is cleared to 0 or 1 at each I/O according to the data of color register. Column addresses A0 and A1 are disregarded. The data on I/Os and addresses can be masked. I/O level at the falling edge of  $\overline{\text{CAS}}$  determines the address to be cleared. (See figure 2.) In a page mode cycle, mixed cycle of normal Read/Write and block write can be allowed by controlling DSF.

- Normal Mode Block Write Cycle ( $\overline{\text{WE}}$  high at the falling edge of  $\overline{\text{RAS}}$ )

The data on 4 I/Os are all cleared when  $\overline{\text{WE}}$  is high at the falling edge of  $\overline{\text{RAS}}$ .

- Mask Block Write Mode ( $\overline{\text{WE}}$  low at the falling edge of  $\overline{\text{RAS}}$ )

When  $\overline{\text{WE}}$  is low at the falling edge of  $\overline{\text{RAS}}$ , the HM534253B starts mask block write mode to clear the data on an optional I/O. The mask data is the same as that of a RAM write cycle. High I/O is cleared, low I/O is not cleared and the internal data is retained. The mask data is available in the  $\overline{\text{RAS}}$  cycle. In page mode block write cycle, the mask data is retained during the page access.

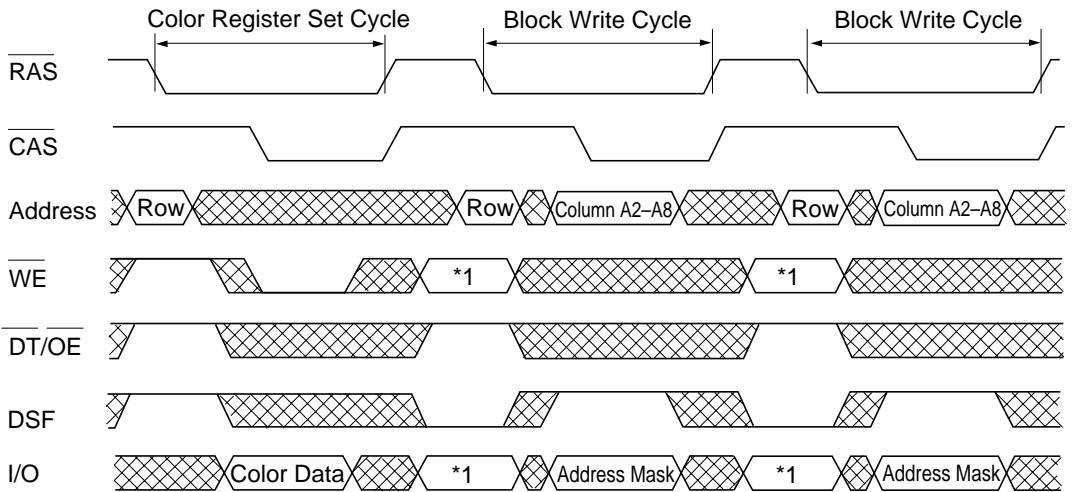

\*1

$\overline{WE}$	I/O	Mode
Low	I/O Mask Data	Mask
High	Don't care	Non mask

I/O Mask Data

Low: Mask

High: Non Mask

Address Mask Data

I/O0	Column0 (A0 = 0, A1 = 0) Mask Data	Low: Mask High: Non Mask
I/O1	Column1 (A0 = 1, A1 = 0) Mask Data	
I/O2	Column2 (A0 = 0, A1 = 1) Mask Data	
I/O3	Column3 (A0 = 1, A1 = 1) Mask Data	

**Figure 2 Use of Block Write**

## Transfer Operation

The HM534253B provides the read transfer cycle, split read transfer cycle, pseudo transfer cycle, write transfer cycle, and split write transfer cycle as data transfer cycles. These transfer cycles are set by driving CAS high and  $\overline{DT/OE}$  low at the falling edge of RAS. They have following functions:

- (1) Transfer data between row address and SAM data register (except for pseudo transfer cycle)
  - Read transfer cycle and split read transfer cycle: RAM to SAM
  - Write transfer cycle and split write transfer cycle: SAM to RAM
- (2) Determine SI/O state (except for split read transfer cycle and split write transfer cycle)
  - Read transfer cycle: SI/O output
  - Pseudo transfer cycle and write transfer cycle: SI/O input
- (3) Determine first SAM address to access after transferring at column address (SAM start address).

SAM start address must be determined by read transfer cycle or pseudo transfer cycle (split transfer cycle isn't available) before SAM access, after power on, and determined for each transfer cycle.

**Read Transfer Cycle** ( $\overline{\text{CAS}}$  high,  $\overline{\text{DT/OE}}$  low,  $\overline{\text{WE}}$  high and DSF low at the falling edge of  $\overline{\text{RAS}}$ )

This cycle becomes read transfer cycle by driving  $\overline{\text{DT/OE}}$  low,  $\overline{\text{WE}}$  high and DSF low at the falling edge of  $\overline{\text{RAS}}$ . The row address data ( $512 \times 4$  bits) determined by this cycle is transferred to SAM data register synchronously at the rising edge of  $\overline{\text{DT/OE}}$ . After the rising edge of  $\overline{\text{DT/OE}}$ , the new address data outputs from SAM start address determined by column address. In read transfer cycle,  $\overline{\text{DT/OE}}$  must be risen to transfer data from RAM to SAM.

This cycle can access SAM even during transfer (real time read transfer). In this case, the timing  $t_{\text{SDD}}$  (min) specified between the last SAM access before transfer and  $\overline{\text{DT/OE}}$  rising edge and  $t_{\text{SDH}}$  (min) specified between the first SAM access and  $\overline{\text{DT/OE}}$  rising edge must be satisfied. (See figure 3.)

When read transfer cycle is executed, SI/O becomes output state by first SAM access. Input must be set high impedance before  $t_{\text{SZS}}$  (min) of the first SAM access to avoid data contention.

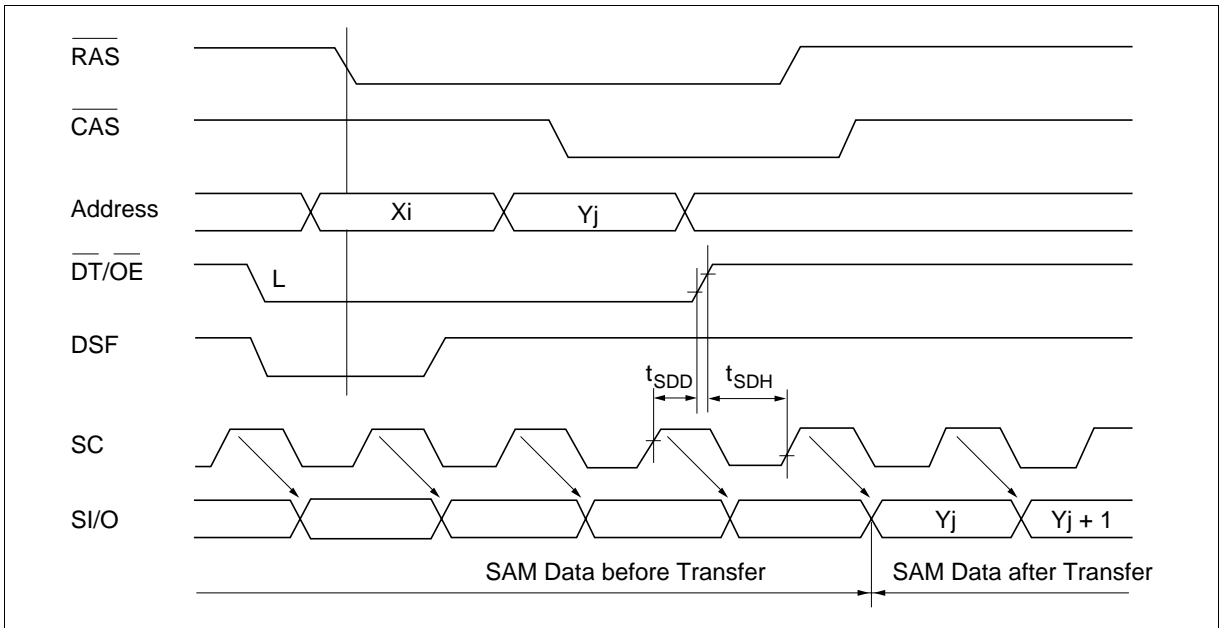

Figure 3 Real Time Read Transfer

**Pseudo Transfer Cycle** ( $\overline{\text{CAS}}$  high,  $\overline{\text{DT/OE}}$  low,  $\overline{\text{WE}}$  low,  $\overline{\text{SE}}$  high and DSF low at the falling edge of  $\overline{\text{RAS}}$ )

Pseudo transfer cycle switches SI/O to input state and set SAM start address without data transfer to RAM.

This cycle starts when  $\overline{\text{CAS}}$  is high,  $\overline{\text{DT/OE}}$  low,  $\overline{\text{WE}}$  low,  $\overline{\text{SE}}$  high and DSF low at the falling edge of  $\overline{\text{RAS}}$ . Data should be input to SI/O later than  $t_{\text{SID}}$  (min) after  $\overline{\text{RAS}}$  becomes low to avoid data contention. SAM access becomes enabled after  $t_{\text{SRD}}$  (min) after  $\overline{\text{RAS}}$  becomes high. In this cycle, SAM access is inhibited during  $\overline{\text{RAS}}$  low, therefore, SC must not be risen.

## Write Transfer Cycle ( $\overline{\text{CAS}}$ high, $\overline{\text{DT/OE}}$ low, $\overline{\text{WE}}$ low, $\overline{\text{SE}}$ low, and DSF low at the falling edge of $\overline{\text{RAS}}$ )

Write transfer cycle can transfer a row of data input by serial write cycle to RAM. The row address of data transferred into RAM is determined by the address at the falling edge of  $\overline{\text{RAS}}$ . The column address is specified as the first address for serial write after terminating this cycle. Also in this cycle, SAM access becomes enabled after  $t_{\text{SRD}}$  (min) after  $\overline{\text{RAS}}$  becomes high. SAM access is inhibited during  $\overline{\text{RAS}}$  low. In this period, SC must not be risen. Data transferred to SAM by read transfer cycle or split read transfer cycle can be written to other addresses of RAM by write transfer cycle. However, the address to write data must be the same MSB of row address (AX8) as that of the read transfer cycle. Figure 4 shows the example of row bit data transfer. In case AX8 is 0, data cannot be transferred RAM address within the range of 100000000 to 111111111. Same as the case of AX8 = 1.

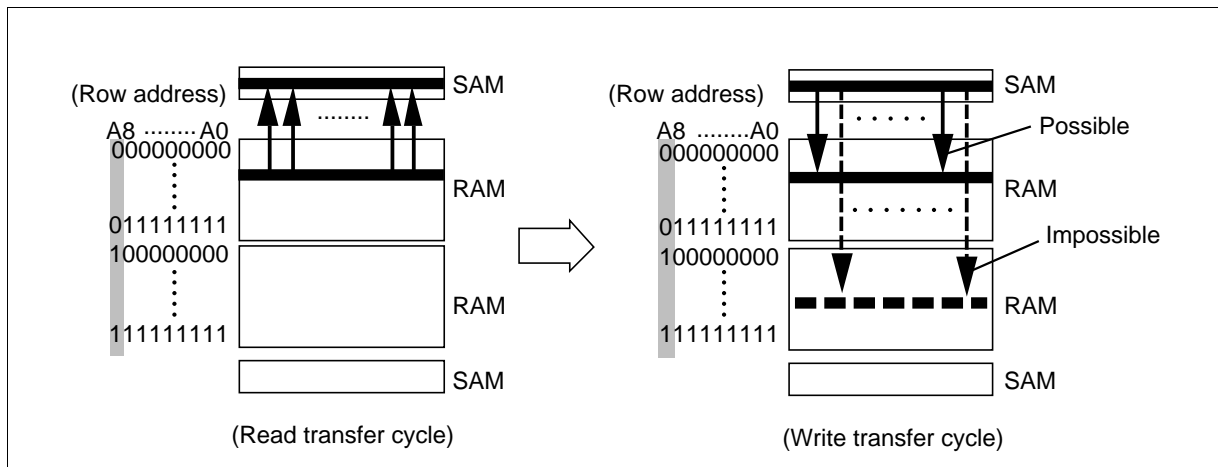

**Figure 4 Example of Row Bit Data Transfer**

## Split Read Transfer Cycle ( $\overline{\text{CAS}}$ high, $\overline{\text{DT/OE}}$ low, $\overline{\text{WE}}$ high and DSF high at the falling edge of $\overline{\text{RAS}}$ )

To execute a continuous serial read by real time read transfer, the HM534253B must satisfy SC and  $\overline{\text{DT/OE}}$  timings and requires an external circuit to detect SAM last address. Split read transfer cycle makes it possible to execute a continuous serial read without the above timing limitation. Figure 5 shows the block diagram for a split transfer. SAMdata register (DR) consists of 2 split buffers, whose organizations are 256-word  $\times$  4-bit each. Let us suppose that data is read from upper data register DR1 (The row address AX8 is 0 and SAM address A8 is 1.). When split read transfer is executed setting row address AX8 0 and SAM start addresses A0 to A7, 256-word  $\times$  4-bit data are transferred from RAM to the lower data register DR0 (SAM address A8 is 0) automatically. After data are read from data register DR1, data start to be read from SAM start addresses of data register DR0. If the next split read transfer isn't executed while data are read from data register DR0, data start to be read from SAM start address 0 of DR1 after data are read from data register DR0. If split read transfer is executed setting row address AX8 1 and SAM start addresses A0 to A7 while data are read from data register DR1, 256-word  $\times$  4-bit data are transferred to data register DR2. After data are read from data register DR1, data start to be read from SAM start addresses of data register DR2. If the next split read transfer isn't executed while data is read from data register DR2, data start to be read from SAM start address 0 of data register DR3 after data are read from data register DR2. In this time, SAM data is the one transferred to data register DR3 finally while row address AX8 is 1. In split read data transfer, the SAM start address A8 is automatically set in the data register which isn't used.

The data on SAM address A8, which will be accessed next, outputs to QSF. QSF is switched from low to high by accessing SAM last address 255 and from high to low by accessing address 511.

Split read transfer cycle is set when  $\overline{\text{CAS}}$  is high,  $\overline{\text{DT/OE}}$  is low,  $\overline{\text{WE}}$  is high and DSF is high at the falling edge of  $\overline{\text{RAS}}$ . The cycle can be executed asynchronously with SC. However,  $t_{\text{STS}}$  (min) timing specified between SC rising and  $\overline{\text{RAS}}$  falling must be satisfied. SAM last address must be accessed, satisfying  $t_{\text{RST}}$  (min),  $t_{\text{CST}}$  (min), and  $t_{\text{AST}}$  (min) timings specified between  $\overline{\text{RAS}}$  or  $\overline{\text{CAS}}$  falling and column address. (See figure 6.)

In split read transfer, SI/O isn't switched to output state. Therefore, read transfer must be executed to switch SI/O to output state when the previous transfer cycle is pseudo transfer or write transfer cycle.

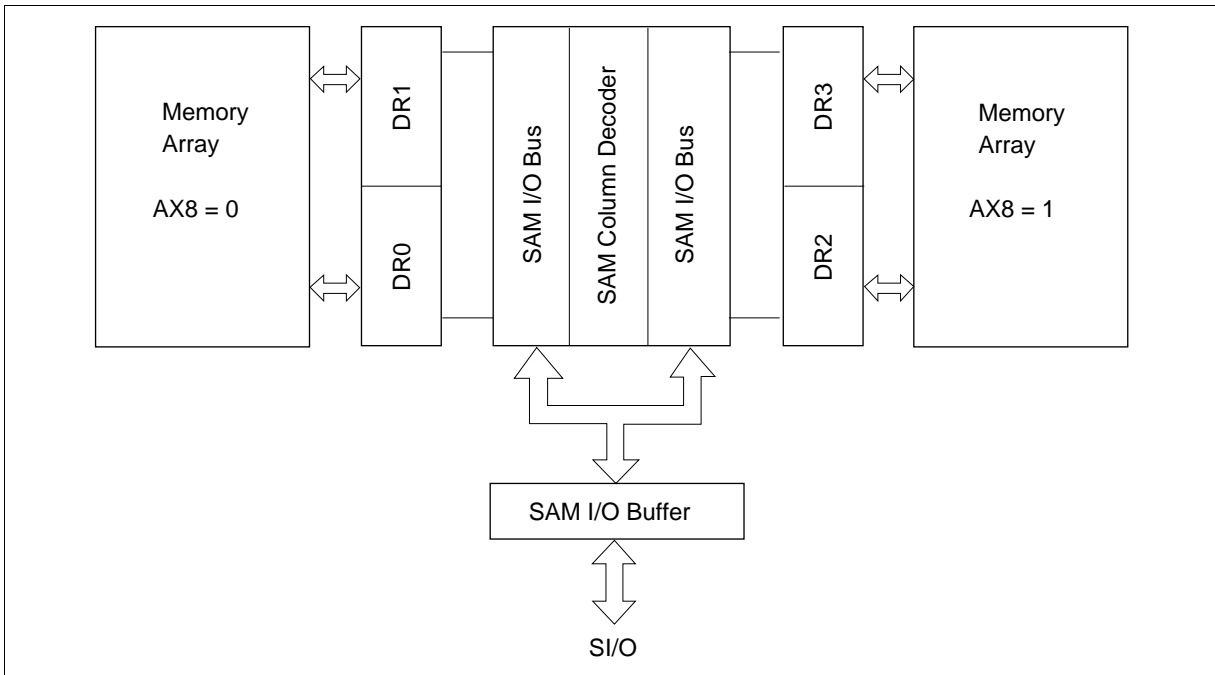

**Figure 5 Block Diagram for Split Transfer**

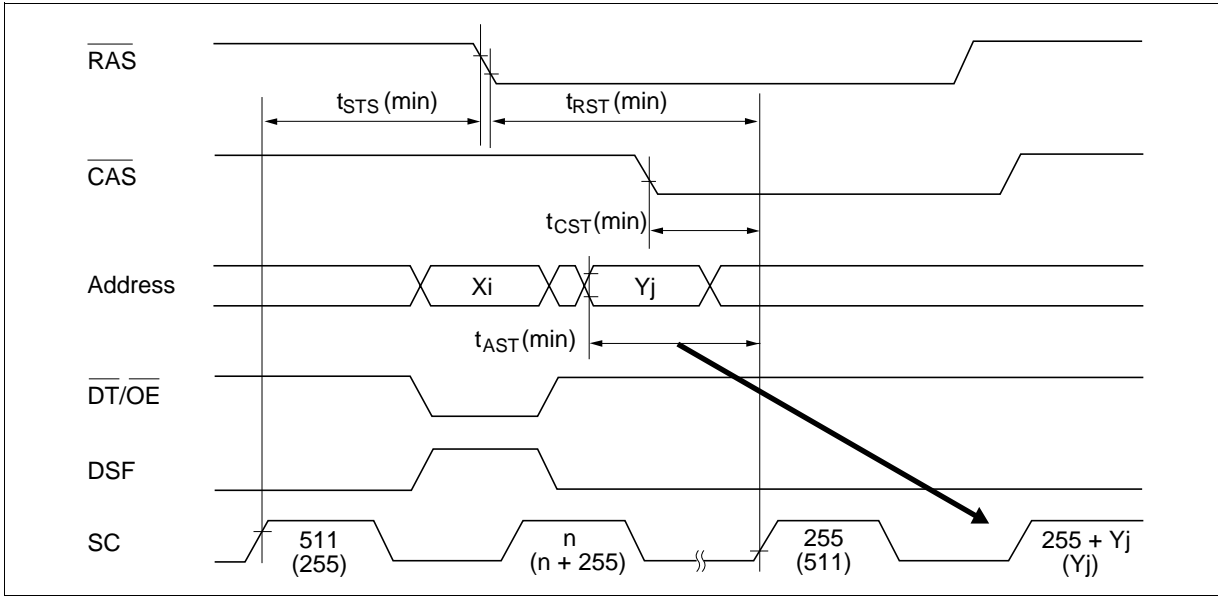

**Figure 6 Limitation in Split Transfer**

**Split Write Transfer Cycle** ( $\overline{\text{CAS}}$  high,  $\overline{\text{DT/OE}}$  low,  $\overline{\text{WE}}$  low and DSF high at the falling edge of  $\overline{\text{RAS}}$ )

A continuous serial write cannot be executed because accessing SAM is inhibited during  $\overline{\text{RAS}}$  low in write transfer. Split write transfer cycle makes it possible. In this cycle,  $t_{\text{STS}}$  (min),  $t_{\text{RST}}$  (min),  $t_{\text{CST}}$  (min) and  $t_{\text{AST}}$  (min) timings must be satisfied like split read transfer cycle. And it is impossible to switch SI/O to input state in this cycle. If SI/O is in output state, pseudo transfer cycle should be executed to switch SI/O into input state. Data transferred to SAM by read transfer cycle or split read transfer cycle can be written to other addresses of RAM by split write transfer cycle. However, pseudo transfer cycle must be executed before split write transfer cycle. And the MSB of row address (AX8) to write data must be the same as that of the read transfer cycle or the split read transfer cycle.

## SAM Port Operation

### Serial Read Cycle

SAM port is in read mode when the previous data transfer cycle is read transfer cycle. Access is synchronized with SC rising, and SAM data is output from SI/O. When  $\overline{\text{SE}}$  is set high, SI/O becomes high impedance, and the internal pointer is incremented by the SC rising. After indicating the last address (address 511), the internal pointer indicates address 0 at the next access.

**Serial Write Cycle**

If previous data transfer cycle is pseudo transfer cycle or write transfer cycle, SAM port goes into write mode. In this cycle, SI/O data is fetched into data register at the SC rising edge like in the serial read cycle. If  $\overline{SE}$  is high, SI/O data isn't fetched into data register. Internal pointer is incremented by the SC rising, so  $\overline{SE}$  high can be used as mask data for SAM. After indicating the last address (address 511), the internal pointer indicates address 0 at the next access.

**Refresh**

**RAM Refresh**

RAM, which is composed of dynamic circuits, requires refresh to retain data. Refresh is executed by accessing all 512 row addresses within 8 ms. There are three refresh cycles: (1)  $\overline{RAS}$ -only refresh cycle, (2)  $\overline{CAS}$ -before- $\overline{RAS}$  (CBR) refresh cycle, and (3) Hidden refresh cycle. Besides them, the cycles which activate  $\overline{RAS}$  such as read/write cycles or transfer cycles can refresh the row address. Therefore, no refresh cycle is required when all row addresses are accessed within 8 ms.

- (1)  $\overline{RAS}$ -Only Refresh Cycle:  $\overline{RAS}$ -only refresh cycle is executed by activating only  $\overline{RAS}$  cycle with  $\overline{CAS}$  fixed to high after inputting the row address (= refresh address) from external circuits. To distinguish this cycle from data transfer cycle,  $\overline{DT/OE}$  must be high at the falling edge of  $\overline{RAS}$ .
- (2) CBR Refresh Cycle: CBR refresh cycle is set by activating  $\overline{CAS}$  before  $\overline{RAS}$ . In this cycle, refresh address need not to be input through external circuits because it is input through an internal refresh counter. In this cycle, output is in high impedance and power dissipation is lowered because  $\overline{CAS}$  circuits don't operate.
- (3) Hidden Refresh Cycle: Hidden refresh cycle executes CBR refresh with the data output by reactivating  $\overline{RAS}$  when  $\overline{DT/OE}$  and  $\overline{CAS}$  keep low in normal RAM read cycles.

**SAM Refresh**

SAM parts (data register, shift register and selector), organized as fully static circuitry, require no refresh.

**Absolute Maximum Ratings**

Parameter	Symbol	Value	Unit	Note
Voltage on any pin relative to $V_{SS}$	$V_T$	-1.0 to +7.0	V	1
Supply voltage relative to $V_{SS}$	$V_{CC}$	-0.5 to +7.0	V	1
Short circuit output current	$I_{out}$	50	mA	
Power dissipation	$P_T$	1.0	W	
Operating temperature	$T_{opr}$	0 to +70	°C	
Storage temperature	$T_{stg}$	-55 to +125	°C	

Note: 1. Relative to  $V_{SS}$ .

# HM534253B Series

## Recommended DC Operating Conditions (Ta = 0 to +70°C)

Parameter	Symbol	Min	Typ	Max	Unit	Notes
Supply voltage	V <sub>CC</sub>	4.5	5.0	5.5	V	1
Input high voltage	V <sub>IH</sub>	2.4	—	6.5	V	1
Input low voltage	V <sub>IL</sub>	-0.5 <sup>2</sup>	—	0.8	V	1

Notes: 1. All voltage referred to V<sub>SS</sub>  
 2 -3.0 V for pulse width ≤ 10 ns.

## DC Characteristics (Ta = 0 to +70°C, V<sub>CC</sub> = 5 V ± 10%, V<sub>SS</sub> = 0 V)

### HM534253B

Parameter	Symbol	-6		-7		-8		-10		Unit	Test Conditions	
		Min	Max	Min	Max	Min	Max	Min	Max			
Operating current	I <sub>CC1</sub>	—	75	—	70	—	60	—	55	mA	$\overline{\text{RAS}}, \overline{\text{CAS}}$ cycling t <sub>RC</sub> = min	SC = V <sub>IL</sub> , $\overline{\text{SE}} = \text{V}_{\text{IH}}$
	I <sub>CC7</sub>	—	125	—	120	—	100	—	95	mA		$\overline{\text{SE}} = \text{V}_{\text{IL}}$ , SC cycling t <sub>SCC</sub> = min
Standby current	I <sub>CC2</sub>	—	7	—	7	—	7	—	7	mA	$\overline{\text{RAS}}, \overline{\text{CAS}} = \text{V}_{\text{IH}}$	SC = V <sub>IL</sub> , $\overline{\text{SE}} = \text{V}_{\text{IH}}$
	I <sub>CC8</sub>	—	50	—	50	—	40	—	40	mA		$\overline{\text{SE}} = \text{V}_{\text{IL}}$ , SC cycling t <sub>SCC</sub> = min
$\overline{\text{RAS}}$ -only refresh current	I <sub>CC3</sub>	—	75	—	70	—	60	—	55	mA	$\overline{\text{RAS}}$ cycling $\overline{\text{CAS}} = \text{V}_{\text{IH}}$ t <sub>RC</sub> = min	SC = V <sub>IL</sub> , $\overline{\text{SE}} = \text{V}_{\text{IH}}$
	I <sub>CC9</sub>	—	125	—	120	—	100	—	95	mA		$\overline{\text{SE}} = \text{V}_{\text{IL}}$ , SC cycling t <sub>SCC</sub> = min
Page mode current	I <sub>CC4</sub>	—	80	—	80	—	70	—	65	mA	$\overline{\text{CAS}}$ cycling $\overline{\text{RAS}} = \text{V}_{\text{IL}}$ t <sub>PC</sub> = min	SC = V <sub>IL</sub> , $\overline{\text{SE}} = \text{V}_{\text{IH}}$
	I <sub>CC10</sub>	—	130	—	130	—	110	—	105	mA		$\overline{\text{SE}} = \text{V}_{\text{IL}}$ , SC cycling t <sub>SCC</sub> = min
$\overline{\text{CAS}}$ -before- $\overline{\text{RAS}}$ refresh current	I <sub>CC5</sub>	—	50	—	45	—	40	—	35	mA	$\overline{\text{RAS}}$ cycling t <sub>RC</sub> = min	SC = V <sub>IL</sub> , $\overline{\text{SE}} = \text{V}_{\text{IH}}$
	I <sub>CC11</sub>	—	100	—	95	—	80	—	75	mA		$\overline{\text{SE}} = \text{V}_{\text{IL}}$ , SC cycling t <sub>SCC</sub> = min



## DC Characteristics (Ta = 0 to +70°C, V<sub>CC</sub> = 5 V ± 10%, V<sub>SS</sub> = 0 V) (cont)

		HM534253B									
		-6		-7		-8		-10			
Parameter	Symbol	Min	Max	Min	Max	Min	Max	Min	Max	Unit	Test Conditions
Data transfer current	I <sub>CC6</sub>	—	80	—	75	—	65	—	60	mA	$\overline{RAS}$ , $\overline{CAS}$ cycling t <sub>RC</sub> = min
	I <sub>CC12</sub>	—	130	—	125	—	105	—	100	mA	$\overline{SE} = V_{IL}$ , SC cycling t <sub>SCC</sub> = min
Input leakage current	I <sub>LI</sub>	-10	10	-10	10	-10	10	-10	10	μA	
Output leakage current	I <sub>LO</sub>	-10	10	-10	10	-10	10	-10	10	μA	
Output high voltage	V <sub>OH</sub>	2.4	—	2.4	—	2.4	—	2.4	—	V	I <sub>OH</sub> = -2 mA
Output low voltage	V <sub>OL</sub>	—	0.4	—	0.4	—	0.4	—	0.4	V	I <sub>OL</sub> = 4.2 mA

- Notes: 1. I<sub>CC</sub> depends on output load condition when the device is selected. I<sub>CC</sub> max is specified at the output open condition.  
 2. Address can be changed once while  $\overline{RAS}$  is low and  $\overline{CAS}$  is high.

## Capacitance (Ta = 25°C, V<sub>CC</sub> = 5 V, f = 1 MHz, Bias: Clock, I/O = V<sub>CC</sub>, address = V<sub>SS</sub>)

Parameter	Symbol	Typ	Max	Unit	Note
Input capacitance (Address)	C <sub>I1</sub>	—	5	pF	1
Input capacitance (Clocks)	C <sub>I2</sub>	—	5	pF	1
Output capacitance (I/O, SI/O, QSF)	C <sub>I/O</sub>	—	7	pF	1

Note: 1. This parameter is sampled and not 100% tested.

## AC Characteristics (Ta = 0 to +70°C, V<sub>CC</sub> = 5 V ± 10%, V<sub>SS</sub> = 0 V)<sup>\*1, \*16</sup>

### Test Conditions

- Input rise and fall time: 5 ns
- Input pulse levels: V<sub>SS</sub> to 3.0 V
- Input timing reference levels: 0.8 V, 2.4 V
- Output timing reference levels: 0.8 V, 2.0 V
- Output load: See figures

# HM534253B Series

## Test Conditions (cont)

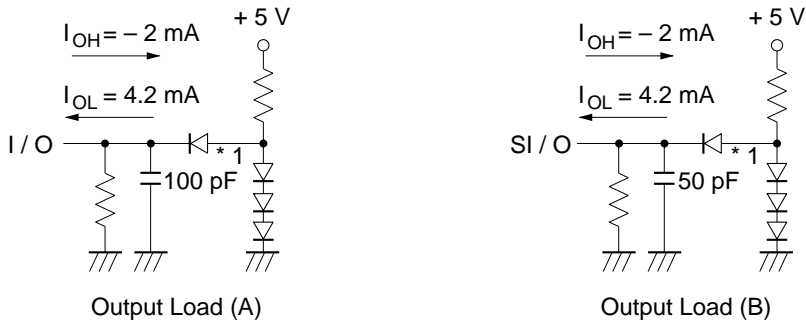

Note: 1. Including scope & jigs

## Common Parameter

### HM534253B

Parameter	Symbol	-6		-7		-8		-10		Unit	Notes
		Min	Max	Min	Max	Min	Max	Min	Max		
Random read or write cycle time	$t_{RC}$	125	—	135	—	150	—	180	—	ns	
$\overline{RAS}$ precharge time	$t_{RP}$	55	—	55	—	60	—	70	—	ns	
$\overline{RAS}$ pulse width	$t_{RAS}$	60	10000	70	10000	80	10000	100	10000	ns	
$\overline{CAS}$ pulse width	$t_{CAS}$	20	—	20	—	20	—	25	—	ns	
Row address setup time	$t_{ASR}$	0	—	0	—	0	—	0	—	ns	
Row address hold time	$t_{RAH}$	10	—	10	—	10	—	10	—	ns	
Column address setup time	$t_{ASC}$	0	—	0	—	0	—	0	—	ns	
Column address hold time	$t_{CAH}$	15	—	15	—	15	—	15	—	ns	
$\overline{RAS}$ to $\overline{CAS}$ delay time	$t_{RCD}$	20	40	20	50	20	60	20	75	ns	2
$\overline{RAS}$ hold time referred to $\overline{CAS}$	$t_{RSH}$	20	—	20	—	20	—	25	—	ns	
$\overline{CAS}$ hold time referred to $\overline{RAS}$	$t_{CSH}$	60	—	70	—	80	—	100	—	ns	
$\overline{CAS}$ to $\overline{RAS}$ precharge time	$t_{CRP}$	10	—	10	—	10	—	10	—	ns	
Transition time (rise to fall)	$t_T$	3	50	3	50	3	50	3	50	ns	3
Refresh period	$t_{REF}$	—	8	—	8	—	8	—	8	ms	
$\overline{DT}$ to $\overline{RAS}$ setup time	$t_{DTS}$	0	—	0	—	0	—	0	—	ns	
$\overline{DT}$ to $\overline{RAS}$ hold time	$t_{DTH}$	10	—	10	—	10	—	10	—	ns	
DSF to $\overline{RAS}$ setup time	$t_{FSR}$	0	—	0	—	0	—	0	—	ns	
DSF to $\overline{RAS}$ hold time	$t_{RFH}$	10	—	10	—	10	—	10	—	ns	

Common Parameter (cont)

		HM534253B									
		-6		-7		-8		-10			
Parameter	Symbol	Min	Max	Min	Max	Min	Max	Min	Max	Unit	Notes
DSF to $\overline{\text{CAS}}$ setup time	$t_{\text{FSC}}$	0	—	0	—	0	—	0	—	ns	
DSF to $\overline{\text{CAS}}$ hold time	$t_{\text{CFH}}$	15	—	15	—	15	—	15	—	ns	
Data-in to $\overline{\text{CAS}}$ delay time	$t_{\text{DZC}}$	0	—	0	—	0	—	0	—	ns	4
Data-in to $\overline{\text{OE}}$ delay time	$t_{\text{DZO}}$	0	—	0	—	0	—	0	—	ns	4
Output buffer turn-off delay referred to $\overline{\text{CAS}}$	$t_{\text{OFF1}}$	—	20	—	20	—	20	—	20	ns	5
Output buffer turn-off delay referred to $\overline{\text{OE}}$	$t_{\text{OFF2}}$	—	20	—	20	—	20	—	20	ns	5

Read Cycle (RAM), Page Mode Read Cycle

		HM534253B									
		-6		-7		-8		-10			
Parameter	Symbol	Min	Max	Min	Max	Min	Max	Min	Max	Unit	Notes
Access time from $\overline{\text{RAS}}$	$t_{\text{RAC}}$	—	60	—	70	—	80	—	100	ns	6, 7
Access time from $\overline{\text{CAS}}$	$t_{\text{CAC}}$	—	20	—	20	—	20	—	25	ns	7, 8
Access time from $\overline{\text{OE}}$	$t_{\text{OAC}}$	—	20	—	20	—	20	—	25	ns	7
Address access time	$t_{\text{AA}}$	—	35	—	35	—	40	—	45	ns	7, 9
Read command setup time	$t_{\text{RCS}}$	0	—	0	—	0	—	0	—	ns	
Read command hold time	$t_{\text{RCH}}$	0	—	0	—	0	—	0	—	ns	10
Read command hold time referred to $\overline{\text{RAS}}$	$t_{\text{RRH}}$	10	—	10	—	10	—	10	—	ns	10
$\overline{\text{RAS}}$ to column address delay time	$t_{\text{RAD}}$	15	25	15	35	15	40	15	55	ns	2
Column address to $\overline{\text{RAS}}$ lead time	$t_{\text{RAL}}$	35	—	35	—	40	—	45	—	ns	
Column address to $\overline{\text{CAS}}$ lead time	$t_{\text{CAL}}$	35	—	35	—	40	—	45	—	ns	
Page mode cycle time	$t_{\text{PC}}$	45	—	45	—	50	—	55	—	ns	
$\overline{\text{CAS}}$ precharge time	$t_{\text{CP}}$	10	—	10	—	10	—	10	—	ns	
Access time from $\overline{\text{CAS}}$ precharge	$t_{\text{ACP}}$	—	40	—	40	—	45	—	50	ns	
Page mode $\overline{\text{RAS}}$ pulse width	$t_{\text{RASP}}$	60	100000	70	100000	80	100000	100	100000	ns	

# HM534253B Series

## Write Cycle (RAM), Page Mode Write Cycle, Color Register Set Cycle

		HM534253B									
		-6		-7		-8		-10			
Parameter	Symbol	Min	Max	Min	Max	Min	Max	Min	Max	Unit	Notes
Write command setup time	$t_{WCS}$	0	—	0	—	0	—	0	—	ns	11
Write command hold time	$t_{WCH}$	15	—	15	—	15	—	15	—	ns	
Write command pulse width	$t_{WP}$	15	—	15	—	15	—	15	—	ns	
Write command to $\overline{RAS}$ lead time	$t_{RWL}$	20	—	20	—	20	—	20	—	ns	
Write command to $\overline{CAS}$ lead time	$t_{CWL}$	20	—	20	—	20	—	20	—	ns	
Data-in setup time	$t_{DS}$	0	—	0	—	0	—	0	—	ns	12
Data-in hold time	$t_{DH}$	15	—	15	—	15	—	15	—	ns	12
$\overline{WE}$ to $\overline{RAS}$ setup time	$t_{WS}$	0	—	0	—	0	—	0	—	ns	
$\overline{WE}$ to $\overline{RAS}$ hold time	$t_{WH}$	10	—	10	—	10	—	10	—	ns	
Mask data to $\overline{RAS}$ setup time	$t_{MS}$	0	—	0	—	0	—	0	—	ns	
Mask data to $\overline{RAS}$ hold time	$t_{MH}$	10	—	10	—	10	—	10	—	ns	
$\overline{OE}$ hold time referred to $\overline{WE}$	$t_{OEH}$	20	—	20	—	20	—	20	—	ns	
Page mode cycle time	$t_{PC}$	45	—	45	—	50	—	55	—	ns	
$\overline{CAS}$ precharge time	$t_{CP}$	10	—	10	—	10	—	10	—	ns	
$\overline{CAS}$ to data-in delay time	$t_{CDD}$	20	—	20	—	20	—	20	—	ns	13
Page mode $\overline{RAS}$ pulse width	$t_{RASP}$	60	100000	70	100000	80	10000	100	100000	ns	

**Read-Modify-Write Cycle**

		HM534253B									
		-6		-7		-8		-10			
Parameter	Symbol	Min	Max	Min	Max	Min	Max	Min	Max	Unit	Notes
Read-modify-write cycle time	$t_{RWC}$	175	—	185	—	200	—	230	—	ns	
$\overline{RAS}$ pulse width (read-modify-write cycle)	$t_{RWS}$	110	10000	120	10000	130	10000	150	10000	ns	
$\overline{CAS}$ to $\overline{WE}$ delay time	$t_{CWD}$	45	—	45	—	45	—	50	—	ns	14
Column address to $\overline{WE}$ delay time	$t_{AWD}$	60	—	60	—	65	—	70	—	ns	14
$\overline{OE}$ to data-in delay time	$t_{ODD}$	20	—	20	—	20	—	20	—	ns	12
Access time from $\overline{RAS}$	$t_{RAC}$	—	60	—	70	—	80	—	100	ns	6, 7
Access time from $\overline{CAS}$	$t_{CAC}$	—	20	—	20	—	20	—	25	ns	7, 8
Access time from $\overline{OE}$	$t_{OAC}$	—	20	—	20	—	20	—	25	ns	7
Address access time	$t_{AA}$	—	35	—	35	—	40	—	45	ns	7, 9
$\overline{RAS}$ to column address delay time	$t_{RAD}$	15	25	15	35	15	40	15	55	ns	
Read command setup time	$t_{RCS}$	0	—	0	—	0	—	0	—	ns	
Write command to $\overline{RAS}$ lead time	$t_{RWL}$	20	—	20	—	20	—	20	—	ns	
Write command to $\overline{CAS}$ lead time	$t_{CWL}$	20	—	20	—	20	—	20	—	ns	
Write command pulse width	$t_{WP}$	15	—	15	—	15	—	15	—	ns	
Data-in setup time	$t_{DS}$	0	—	0	—	0	—	0	—	ns	12
Data-in hold time	$t_{DH}$	15	—	15	—	15	—	15	—	ns	12
$\overline{OE}$ hold time referred to $\overline{WE}$	$t_{OEH}$	20	—	20	—	20	—	20	—	ns	

**Refresh Cycle**

		HM534253B									
		-6		-7		-8		-10			
Parameter	Symbol	Min	Max	Min	Max	Min	Max	Min	Max	Unit	Notes
$\overline{CAS}$ setup time ( $\overline{CAS}$ -before- $\overline{RAS}$ refresh)	$t_{CSR}$	10	—	10	—	10	—	10	—	ns	
$\overline{CAS}$ hold time ( $\overline{CAS}$ -before- $\overline{RAS}$ refresh)	$t_{CHR}$	10	—	10	—	10	—	10	—	ns	
$\overline{RAS}$ precharge to $\overline{CAS}$ hold time	$t_{RPC}$	10	—	10	—	10	—	10	—	ns	

# HM534253B Series

## Flash Write Cycle, Block Write Cycle

		HM534253B									
		-6		-7		-8		-10			
Parameter	Symbol	Min	Max	Min	Max	Min	Max	Min	Max	Unit	Notes
CAS to data-in delay time	$t_{\text{CDD}}$	20	—	20	—	20	—	20	—	ns	13
OE to data-in delay time	$t_{\text{ODD}}$	20	—	20	—	20	—	20	—	ns	13

## Read Transfer Cycle

		HM534253B									
		-6		-7		-8		-10			
Parameter	Symbol	Min	Max	Min	Max	Min	Max	Min	Max	Unit	Notes
$\overline{\text{DT}}$ hold time referred to $\overline{\text{RAS}}$	$t_{\text{RDH}}$	50	10000	60	10000	65	10000	80	10000	ns	
$\overline{\text{DT}}$ hold time referred to $\overline{\text{CAS}}$	$t_{\text{CDH}}$	20	—	20	—	20	—	25	—	ns	
$\overline{\text{DT}}$ hold time referred to column address	$t_{\text{ADH}}$	25	—	25	—	30	—	30	—	ns	
$\overline{\text{DT}}$ precharge time	$t_{\text{DTP}}$	20	—	20	—	20	—	30	—	ns	
$\overline{\text{DT}}$ to $\overline{\text{RAS}}$ delay time	$t_{\text{DRD}}$	65	—	65	—	70	—	80	—	ns	
SC to $\overline{\text{RAS}}$ setup time	$t_{\text{SRS}}$	25	—	25	—	30	—	30	—	ns	
1st SC to $\overline{\text{RAS}}$ hold time	$t_{\text{SRH}}$	60	—	70	—	80	—	100	—	ns	
1st SC to $\overline{\text{CAS}}$ hold time	$t_{\text{SCH}}$	25	—	25	—	25	—	25	—	ns	
1st SC to column address hold time	$t_{\text{SAH}}$	40	—	40	—	45	—	50	—	ns	
Last SC to $\overline{\text{DT}}$ delay time	$t_{\text{SDD}}$	5	—	5	—	5	—	5	—	ns	
Last SC to $\overline{\text{DT}}$ delay time	$t_{\text{SDD2}}$	25	—	25	—	25	—	25	—	ns	19
1st SC to $\overline{\text{DT}}$ hold time	$t_{\text{SDH}}$	10	—	10	—	15	—	15	—	ns	
$\overline{\text{RAS}}$ to QSF delay time	$t_{\text{ROD}}$	—	65	—	70	—	75	—	85	ns	15
$\overline{\text{CAS}}$ to QSF delay time	$t_{\text{CQD}}$	—	35	—	35	—	40	—	40	ns	15
$\overline{\text{DT}}$ to QSF delay time	$t_{\text{DQD}}$	—	35	—	35	—	35	—	35	ns	15
QSF hold time referred to $\overline{\text{RAS}}$	$t_{\text{ROH}}$	20	—	20	—	20	—	25	—	ns	
QSF hold time referred to $\overline{\text{CAS}}$	$t_{\text{CQH}}$	5	—	5	—	5	—	5	—	ns	
QSF hold time referred to $\overline{\text{DT}}$	$t_{\text{DOH}}$	5	—	5	—	5	—	5	—	ns	
Serial data-in to 1st SC delay time	$t_{\text{SZS}}$	0	—	0	—	0	—	0	—	ns	
Serial clock cycle time	$t_{\text{SCC}}$	25	—	25	—	30	—	30	—	ns	

Read Transfer Cycle (cont)

		HM534253B									
		-6		-7		-8		-10			
Parameter	Symbol	Min	Max	Min	Max	Min	Max	Min	Max	Unit	Notes
SC pulse width	$t_{SC}$	5	—	5	—	10	—	10	—	ns	
SC precharge time	$t_{SCP}$	10	—	10	—	10	—	10	—	ns	
SC access time	$t_{SCA}$	—	20	—	22	—	25	—	25	ns	15
Serial data-out hold time	$t_{SOH}$	5	—	5	—	5	—	5	—	ns	
Serial data-in setup time	$t_{SIS}$	0	—	0	—	0	—	0	—	ns	
Serial data-in hold time	$t_{SIH}$	15	—	15	—	15	—	15	—	ns	
$\overline{RAS}$ to column address delay time	$t_{RAD}$	15	25	15	35	15	40	15	55	ns	
Column address to $\overline{RAS}$ lead time	$t_{RAL}$	35	—	35	—	40	—	45	—	ns	
$\overline{RAS}$ precharge to $\overline{DT}$ high hold time	$t_{DTHH}$	10	—	10	—	10	—	10	—	ns	18

# HM534253B Series

## Pseudo Transfer Cycle, Write Transfer Cycle

Parameter	Symbol	HM534253B								Unit	Notes
		-6		-7		-8		-10			
		Min	Max	Min	Max	Min	Max	Min	Max		
$\overline{SE}$ setup time referred to $\overline{RAS}$	$t_{ES}$	0	—	0	—	0	—	0	—	ns	
$\overline{SE}$ hold time referred to $\overline{RAS}$	$t_{EH}$	10	—	10	—	10	—	10	—	ns	
SC setup time referred to $\overline{RAS}$	$t_{SRS}$	25	—	25	—	30	—	30	—	ns	
$\overline{RAS}$ to SC delay time	$t_{SRD}$	20	—	20	—	25	—	25	—	ns	
Serial output buffer turn-off time referred to $\overline{RAS}$	$t_{SRZ}$	10	40	10	40	10	45	10	50	ns	
$\overline{RAS}$ to serial data-in delay time	$t_{SID}$	40	—	40	—	45	—	50	—	ns	
$\overline{RAS}$ to QSF delay time	$t_{ROD}$	—	65	—	70	—	75	—	85	ns	15
$\overline{CAS}$ to QSF delay time	$t_{COD}$	—	35	—	35	—	40	—	40	ns	15
QSF hold time referred to $\overline{RAS}$	$t_{ROH}$	20	—	20	—	20	—	25	—	ns	
QSF hold time referred to $\overline{CAS}$	$t_{COH}$	5	—	5	—	5	—	5	—	ns	
Serial clock cycle time	$t_{SCC}$	25	—	25	—	30	—	30	—	ns	
SC pulse width	$t_{SC}$	5	—	5	—	10	—	10	—	ns	
SC precharge time	$t_{SCP}$	10	—	10	—	10	—	10	—	ns	
SC access time	$t_{SCA}$	—	20	—	22	—	25	—	25	ns	15
$\overline{SE}$ access time	$t_{SEA}$	—	20	—	22	—	25	—	25	ns	15
Serial data-out hold time	$t_{SOH}$	5	—	5	—	5	—	5	—	ns	
Serial write enable setup time	$t_{SWS}$	5	—	5	—	5	—	5	—	ns	
Serial data-in setup time	$t_{SIS}$	0	—	0	—	0	—	0	—	ns	
Serial data-in hold time	$t_{SIH}$	15	—	15	—	15	—	15	—	ns	



**Split Read Transfer Cycle, Split Write Transfer Cycle**

		HM534253B									
		-6		-7		-8		-10			
Parameter	Symbol	Min	Max	Min	Max	Min	Max	Min	Max	Unit	Notes
Split transfer setup time	$t_{STS}$	20	—	20	—	20	—	25	—	ns	
Split transfer hold time referred to $\overline{RAS}$	$t_{RST}$	60	—	70	—	80	—	100	—	ns	
Split transfer hold time referred to $\overline{CAS}$	$t_{CST}$	20	—	20	—	20	—	25	—	ns	
Split transfer hold time referred to column address	$t_{AST}$	35	—	35	—	40	—	45	—	ns	
SC to QSF delay time	$t_{SOD}$	—	30	—	30	—	30	—	30	ns	15
QSF hold time referred to SC	$t_{SOH}$	5	—	5	—	5	—	5	—	ns	
Serial clock cycle time	$t_{SCC}$	25	—	25	—	30	—	30	—	ns	
SC pulse width	$t_{SC}$	5	—	5	—	10	—	10	—	ns	
SC precharge time	$t_{SCP}$	10	—	10	—	10	—	10	—	ns	
SC access time	$t_{SCA}$	—	20	—	22	—	25	—	25	ns	15
Serial data-out hold time	$t_{SOH}$	5	—	5	—	5	—	5	—	ns	
Serial data-in setup time	$t_{SIS}$	0	—	0	—	0	—	0	—	ns	
Serial data-in hold time	$t_{SIH}$	15	—	15	—	15	—	15	—	ns	
$\overline{RAS}$ to column address delay time	$t_{RAD}$	15	25	15	35	15	40	15	55	ns	
Column address to $\overline{RAS}$ lead time	$t_{RAL}$	35	—	35	—	40	—	45	—	ns	

# HM534253B Series

## Serial Read Cycle, Serial Write Cycle

		HM534253B									
		-6		-7		-8		-10			
Parameter	Symbol	Min	Max	Min	Max	Min	Max	Min	Max	Unit	Notes
Serial clock cycle time	$t_{SCC}$	25	—	25	—	30	—	30	—	ns	
SC pulse width	$t_{SC}$	5	—	5	—	10	—	10	—	ns	
SC precharge width	$t_{SCP}$	10	—	10	—	10	—	10	—	ns	
Access time from SC	$t_{SCA}$	—	20	—	22	—	25	—	25	ns	15
Access time from $\overline{SE}$	$t_{SEA}$	—	20	—	22	—	25	—	25	ns	15
Serial data-out hold time	$t_{SOH}$	5	—	5	—	5	—	5	—	ns	
Serial output buffer turn-off time referred to $\overline{SE}$	$t_{SEZ}$	—	20	—	20	—	20	—	20	ns	5
Serial data-in setup time	$t_{SIS}$	0	—	0	—	0	—	0	—	ns	
Serial data-in hold time	$t_{SIH}$	15	—	15	—	15	—	15	—	ns	
Serial write enable setup time	$t_{SWS}$	5	—	5	—	5	—	5	—	ns	
Serial write enable hold time	$t_{SWH}$	15	—	15	—	15	—	15	—	ns	
Serial write disable setup time	$t_{SWIS}$	5	—	5	—	5	—	5	—	ns	
Serial write disable hold time	$t_{SWIH}$	15	—	15	—	15	—	15	—	ns	

Notes: 1. AC measurements assume  $t_T = 5$  ns.

- When  $t_{RCD} > t_{RCD}(\max)$  and  $t_{RAD} > t_{RAD}(\max)$ , access time is specified by  $t_{CAC}$  or  $t_{AA}$ .
- $V_{IH}(\min)$  and  $V_{IL}(\max)$  are reference levels for measuring timing of input signals. Transition time  $t_T$  is measured between  $V_{IH}$  and  $V_{IL}$ .
- Data input must be floating before output buffer is turned on. In read cycle, read-modify-write cycle and delayed write cycle, either  $t_{DZC}(\min)$  or  $t_{DZO}(\min)$  must be satisfied.
- $t_{OFF1}(\max)$ ,  $t_{OFF2}(\max)$ , and  $t_{SEZ}(\max)$  are defined as the time at which the output achieves the open circuit condition ( $V_{OH} - 100$  mV,  $V_{OL} + 100$  mV).
- Assume that  $t_{RCD} \leq t_{RCD}(\max)$  and  $t_{RAD} \leq t_{RAD}(\max)$ . If  $t_{RCD}$  or  $t_{RAD}$  is greater than the maximum recommended value shown in this table,  $t_{RAC}$  exceeds the value shown.
- Measured with a load circuit equivalent to 2 TTL loads and 100 pF.
- When  $t_{RCD} \geq t_{RCD}(\max)$  and  $t_{RAD} \leq t_{RAD}(\max)$ , access time is specified by  $t_{CAC}$ .
- When  $t_{RCD} \leq t_{RCD}(\max)$  and  $t_{RAD} \geq t_{RAD}(\max)$ , access time is specified by  $t_{AA}$ .
- If either  $t_{RCH}$  or  $t_{RRH}$  is satisfied, operation is guaranteed.
- When  $t_{WCS} \geq t_{WCS}(\min)$ , the cycle is an early write cycle, and I/O pins remain in an open circuit (high impedance) condition.
- These parameters are specified by the later falling edge of  $\overline{CAS}$  or  $\overline{WE}$ .
- Either  $t_{ODD}(\min)$  or  $t_{ODD}(\min)$  must be satisfied because output buffer must be turned off by  $\overline{CAS}$  or  $\overline{OE}$  prior to applying data to the device when output buffer is on.
- When  $t_{AWD} \geq t_{AWD}(\min)$  and  $t_{CWD} \geq t_{CWD}(\min)$  in read-modify-write cycle, the data of the selected address outputs to an I/O pin and input data is written into the selected address.  $t_{ODD}(\min)$  must be satisfied because output buffer must be turned off by  $\overline{OE}$  prior to applying data to the device.
- Measured with a load circuit equivalent to 2 TTL loads and 50 pF.

16. After power-up, pause for 100  $\mu$ s or more and execute at least 8 initialization cycle (normal memory cycle or refresh cycle), then start operation.
17. When the serial write cycle is used, at least one SC pulse is required before proper SAM operation after  $V_{CC}$  stabilized.
18.  $t_{DTHH}$  (min) must be satisfied only if  $\overline{DT/OE}$  rises up before  $\overline{RAS}$  rises in a read transfer cycle.
19. After read transfer cycle, if split read transfer cycle is executed without SC access and SC address is 254 or 510,  $t_{SDD2}$  (min) must be satisfied 25 ns. Except for those cases,  $t_{SDD}$  (min) is effective and satisfied 5 ns.
20. XXX: H or L (H:  $V_{IH}$  (min)  $\leq V_{IN} \leq V_{IH}$  (max), L:  $V_{IL}$  (min)  $\leq V_{IN} \leq V_{IL}$  (max))  
 //: Invalid Dout

## Timing Waveforms\*20

### Read Cycle

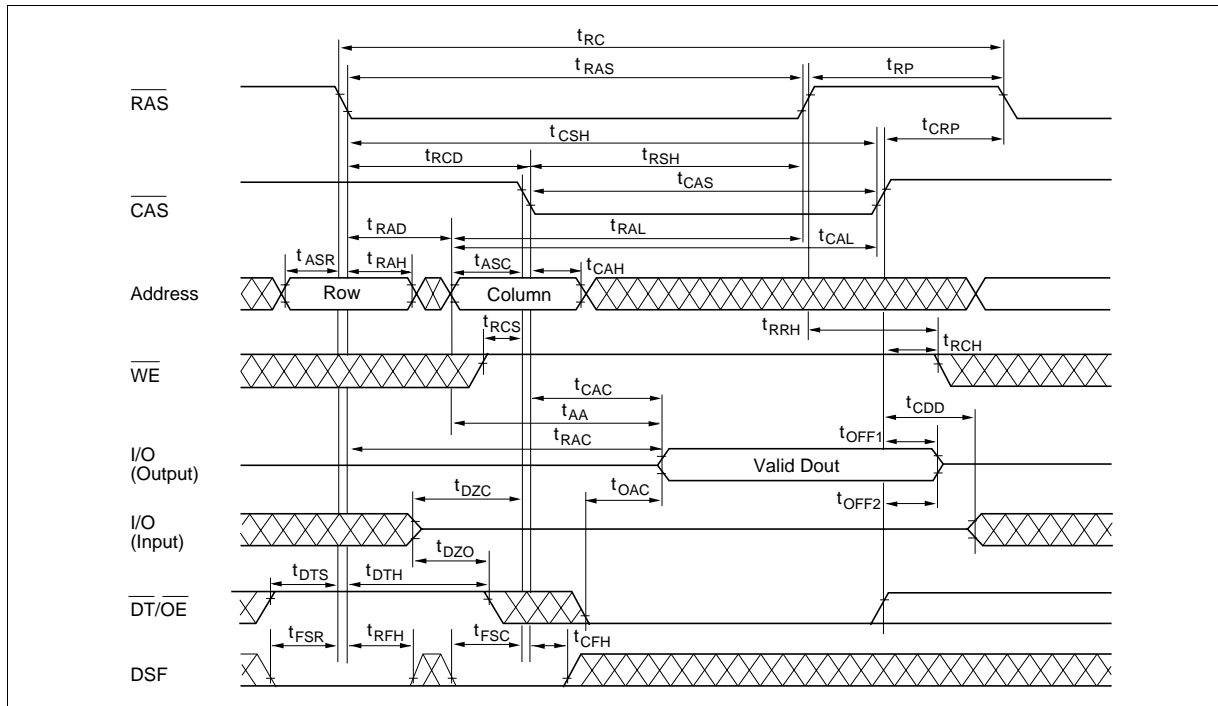

## Early Write Cycle

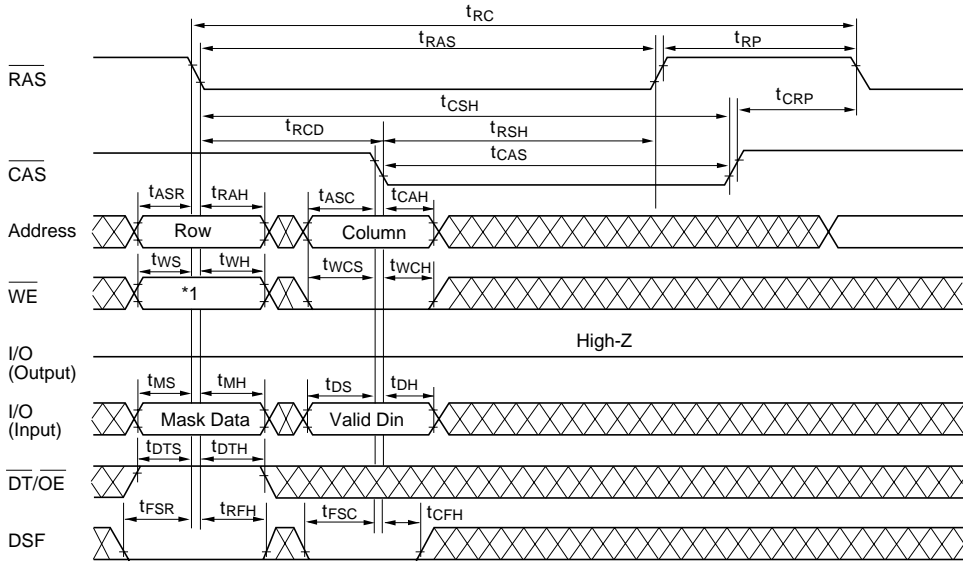

Note: 1. This cycle becomes a normal mode write cycle when  $\overline{WE}$  is high and a mask write cycle when  $\overline{WE}$  is low.

## Delayed Write Cycle

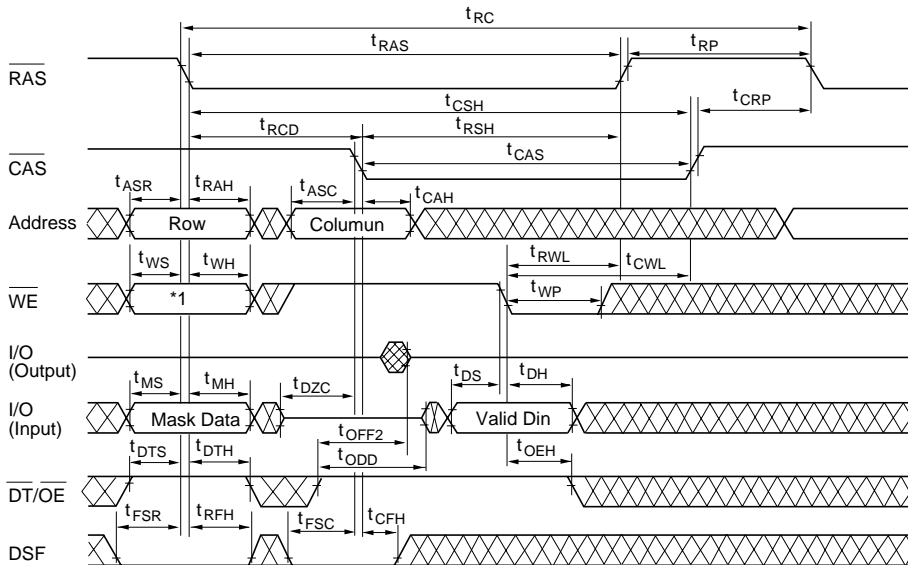

Note: 1. This cycle becomes a normal mode write cycle when  $\overline{WE}$  is high and a mask write cycle when  $\overline{WE}$  is low.



## Page Mode Write Cycle (Early Write)

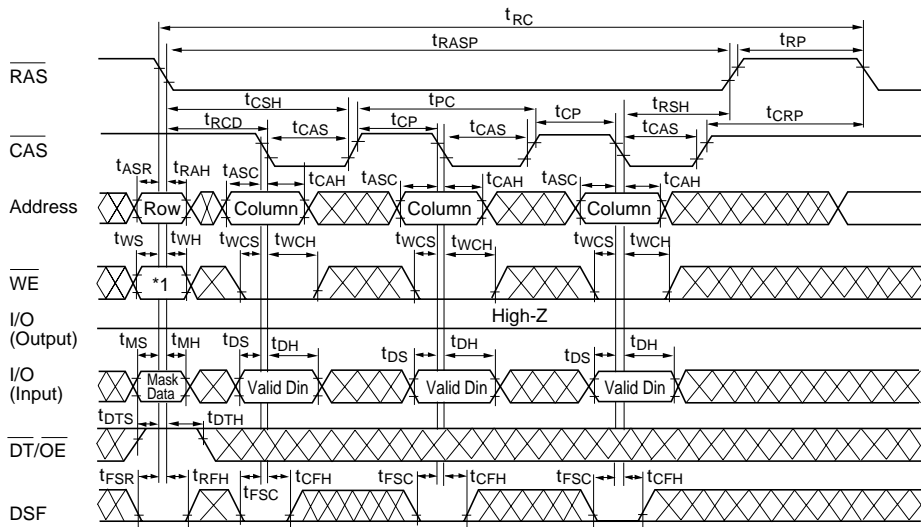

Note: 1. This cycle becomes a normal mode write cycle when  $\overline{WE}$  is high and a mask write cycle when  $\overline{WE}$  is low.

## Page Mode Write Cycle (Delayed Write)

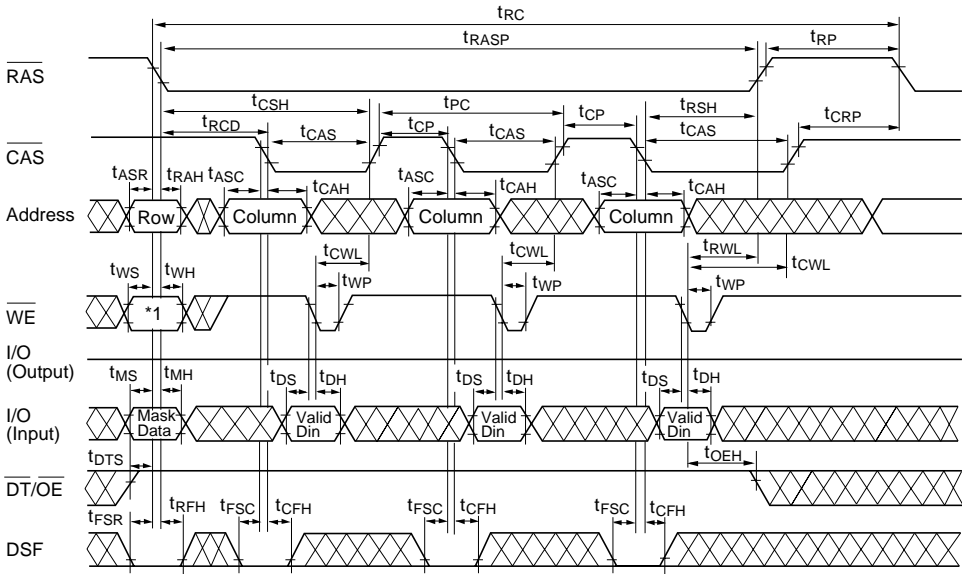

Note: 1. This cycle becomes a normal mode write cycle when  $\overline{WE}$  is high and a mask write cycle when  $\overline{WE}$  is low.

**RAS-Only Refresh Cycle**

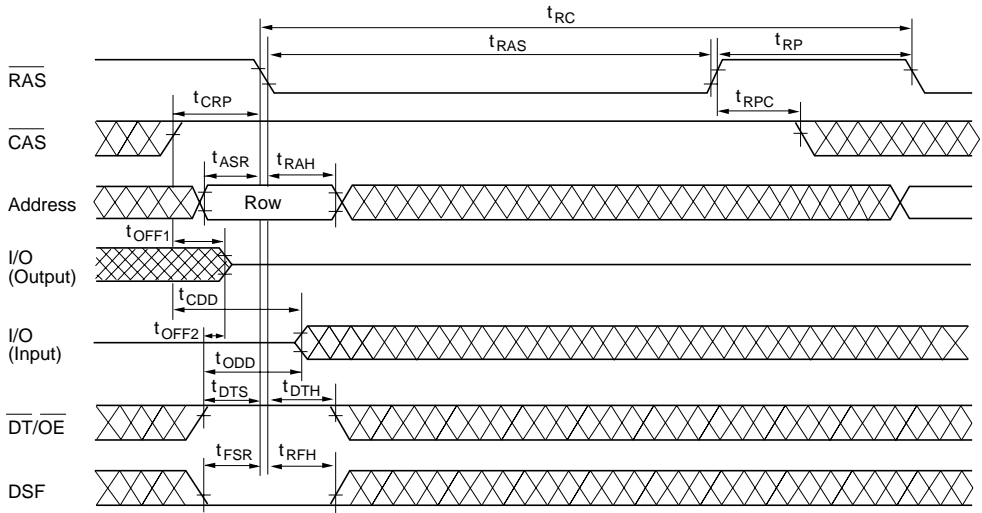

**CAS-Before-RAS Refresh Cycle**

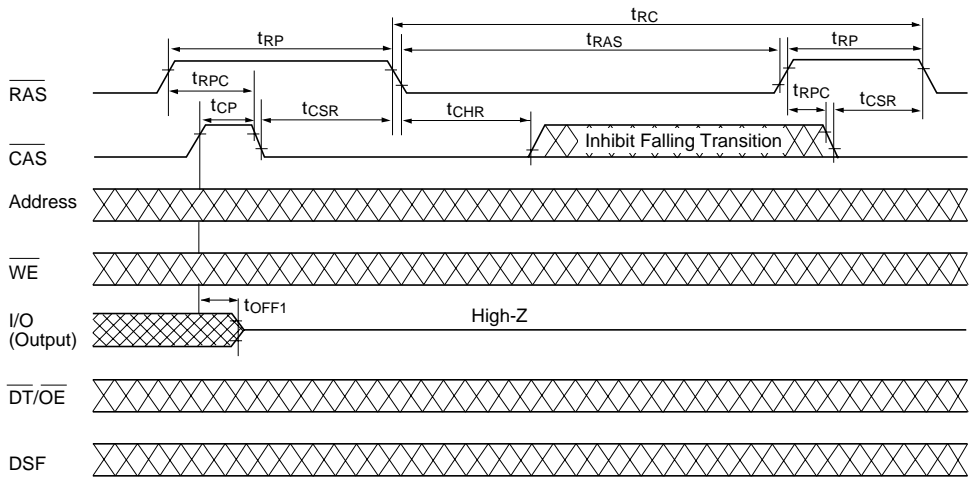

## Hidden Refresh Cycle

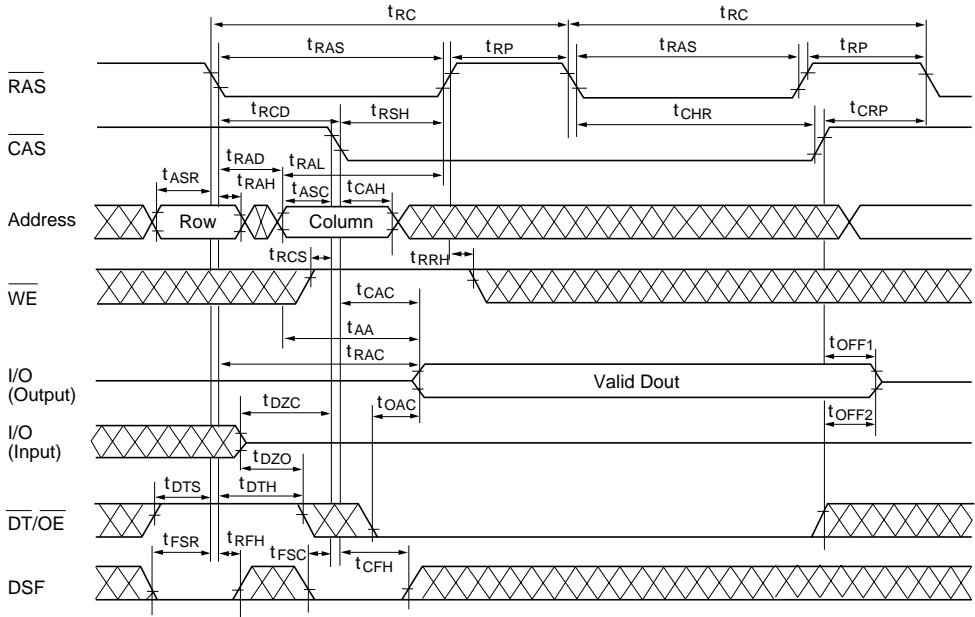

## Color Register Set Cycle (Early Write)

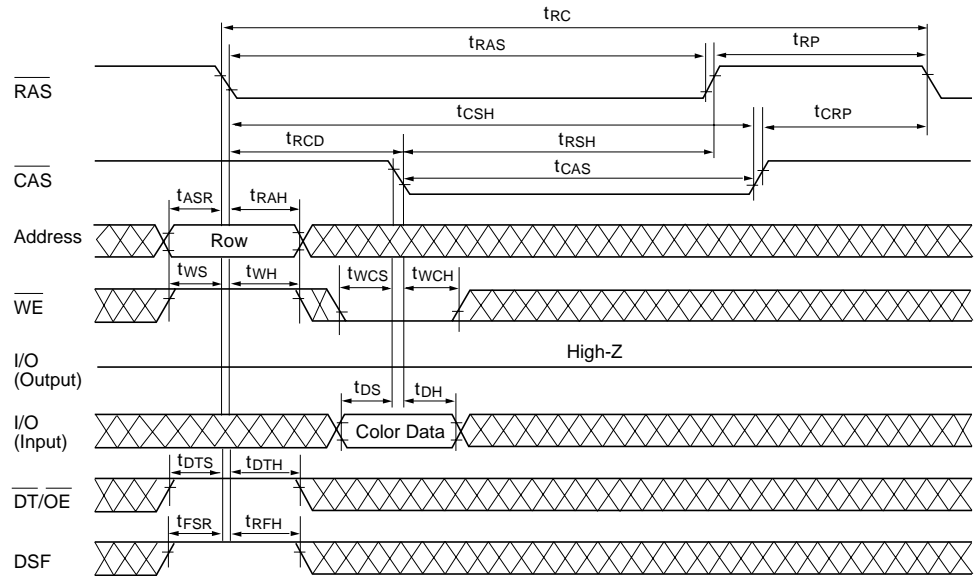





## Flash Write Cycle

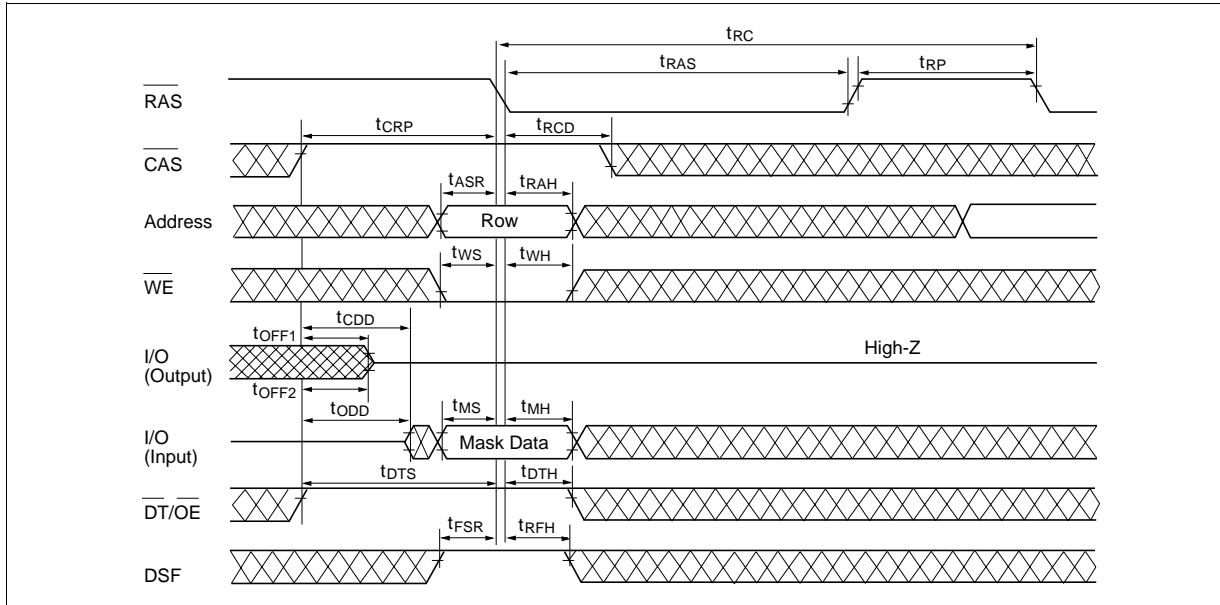

## Block Write Cycle

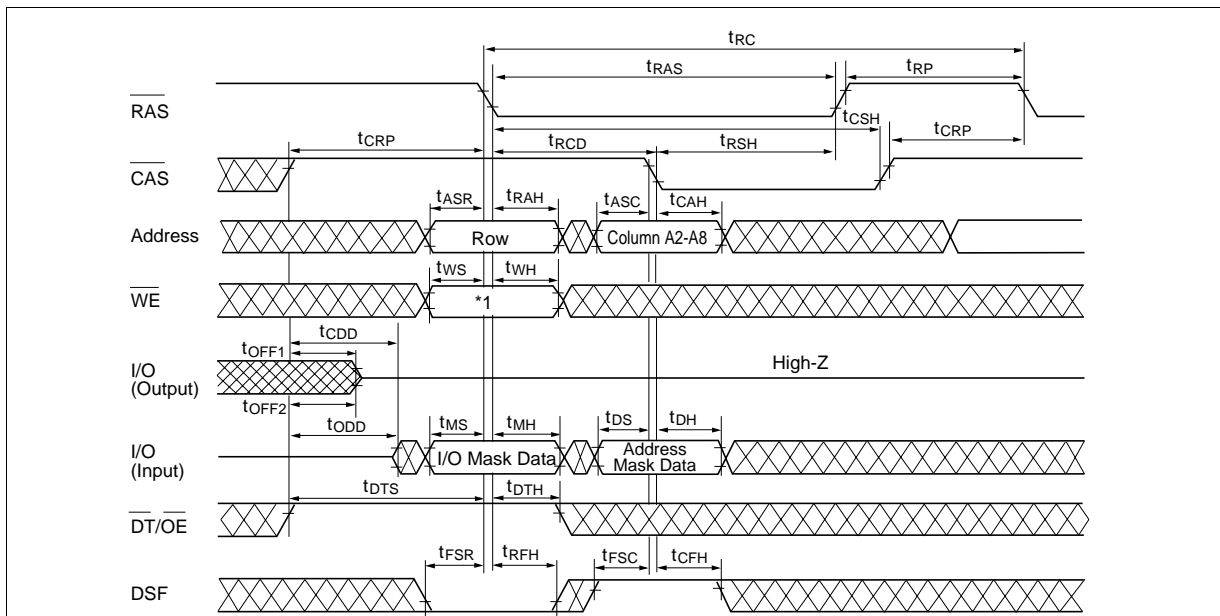

Note: 1. This cycle becomes a normal block write cycle when  $\overline{WE}$  is high and a mask block write cycle when  $\overline{WE}$  is low.

Page Mode Block Write Cycle

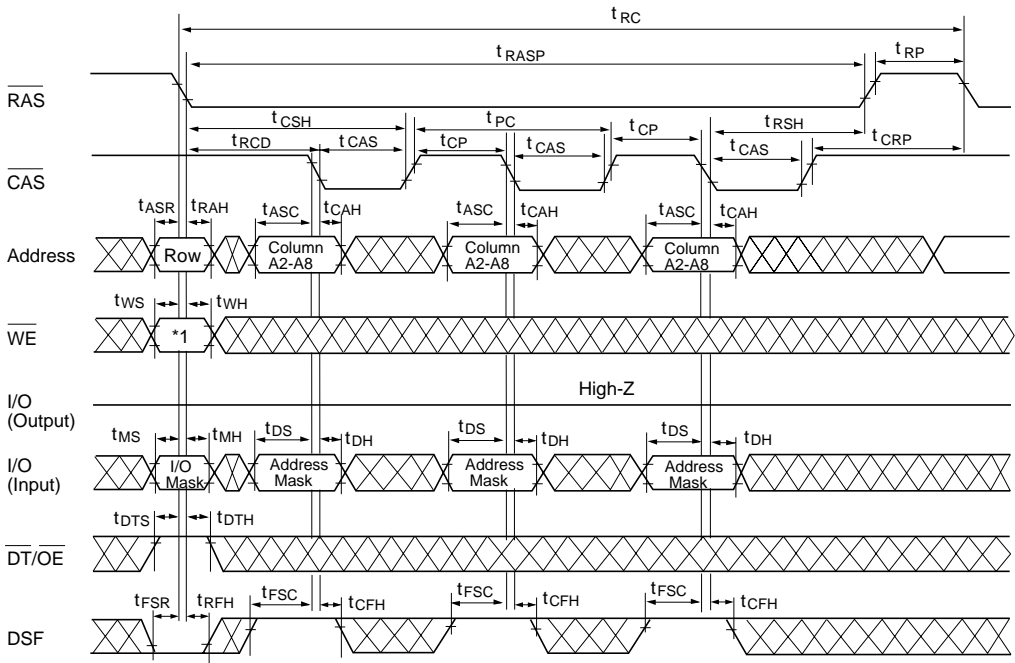

Note: 1. This cycle becomes a normal block write cycle when  $\overline{WE}$  is high and a mask block write cycle when  $\overline{WE}$  is low.

## Read Transfer Cycle (1)

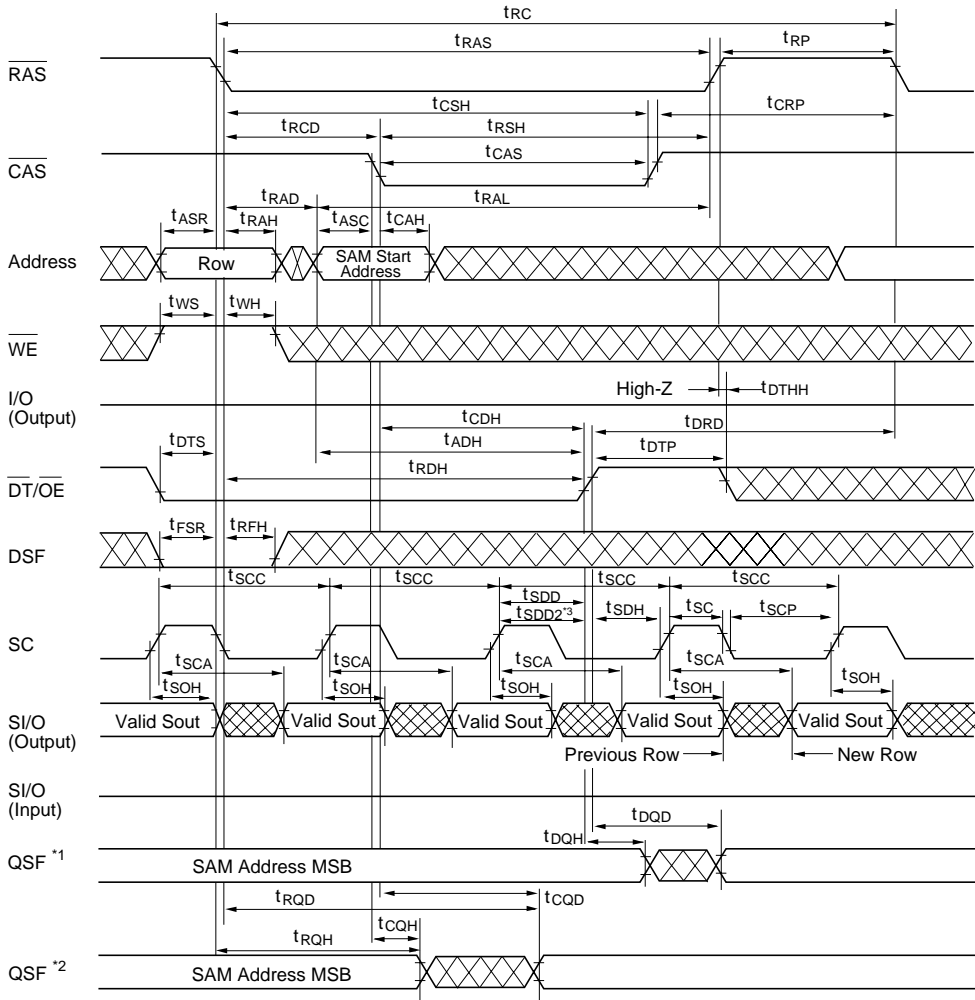

- Notes:
1. This QSF timing is referred when SC is risen once or more between the previous transfer cycle and CAS falling edge of this cycle (QSF is switched by DT rising).
  2. This QSF timing is referred when SC isn't risen between the previous transfer cycle and CAS falling edge of this cycle (QSF is switched by RAS or CAS falling).
  3. After read transfer cycle, if split read transfer cycle is executed without SC access and SC address is 254 or 510,  $t_{SDD2}$  (min) must be satisfied 25 ns. Except for those cases,  $t_{SDD}$  (min) is effective and satisfied 5 ns.

Read Transfer Cycle (2)

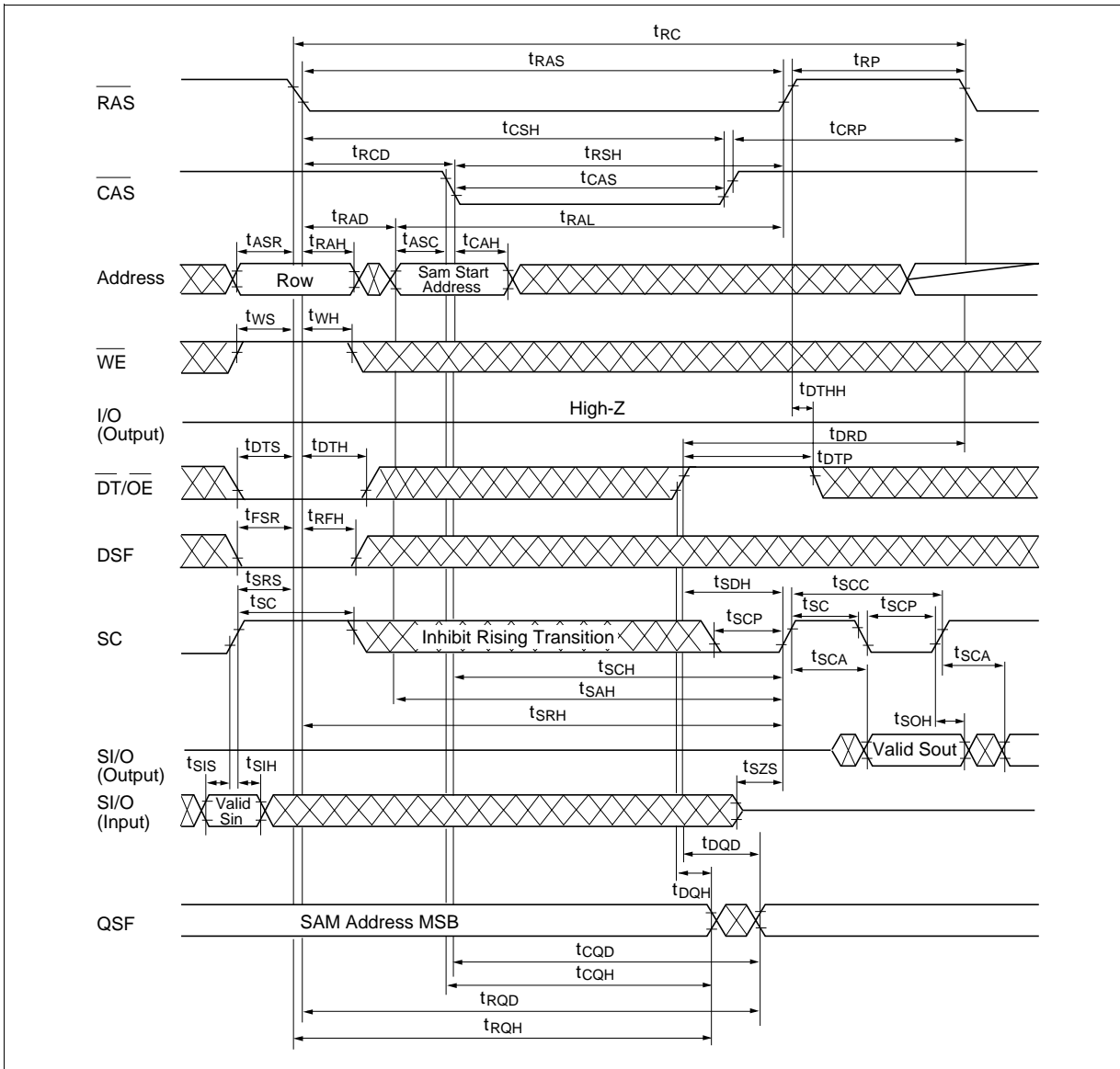

## Pseudo Transfer Cycle

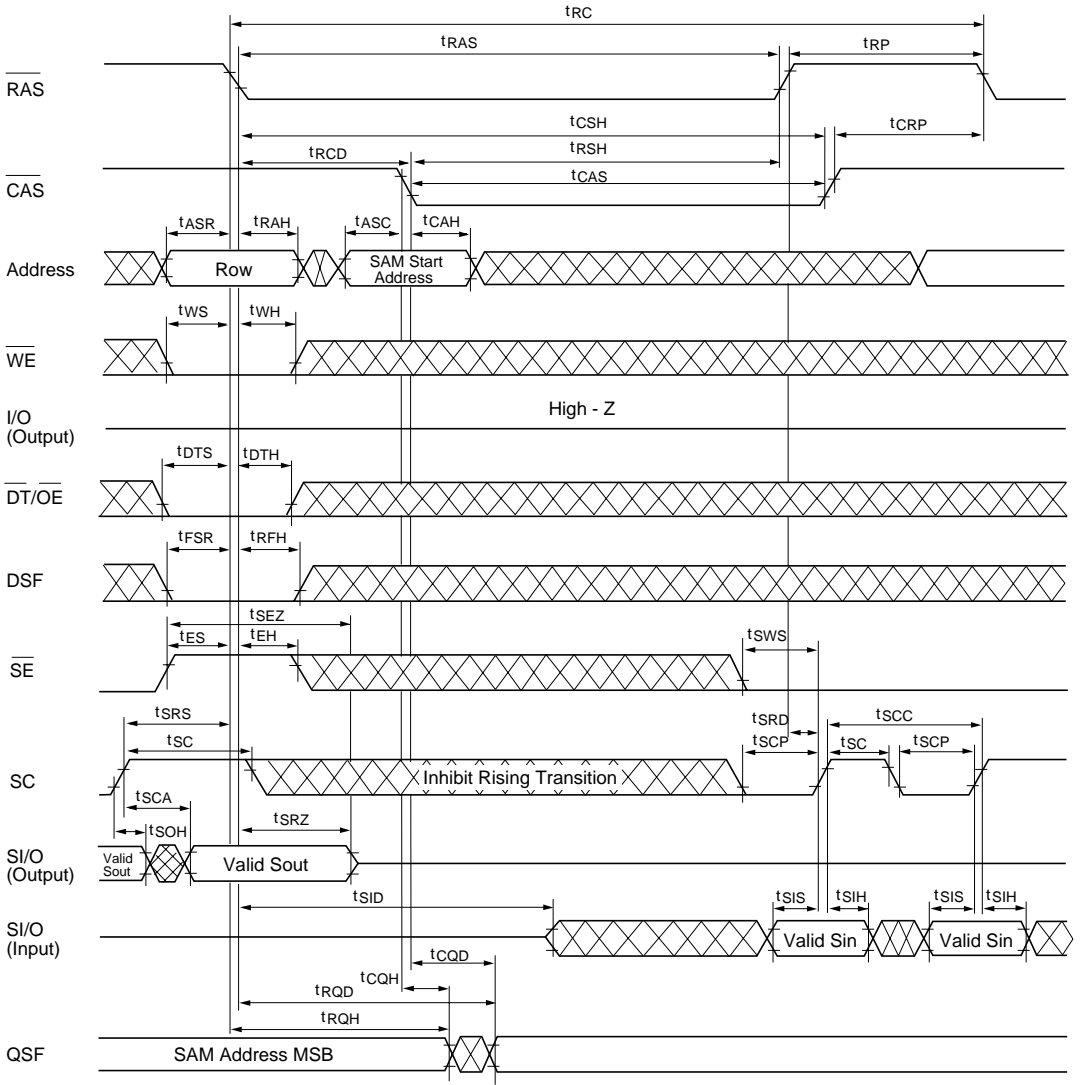

Write Transfer Cycle

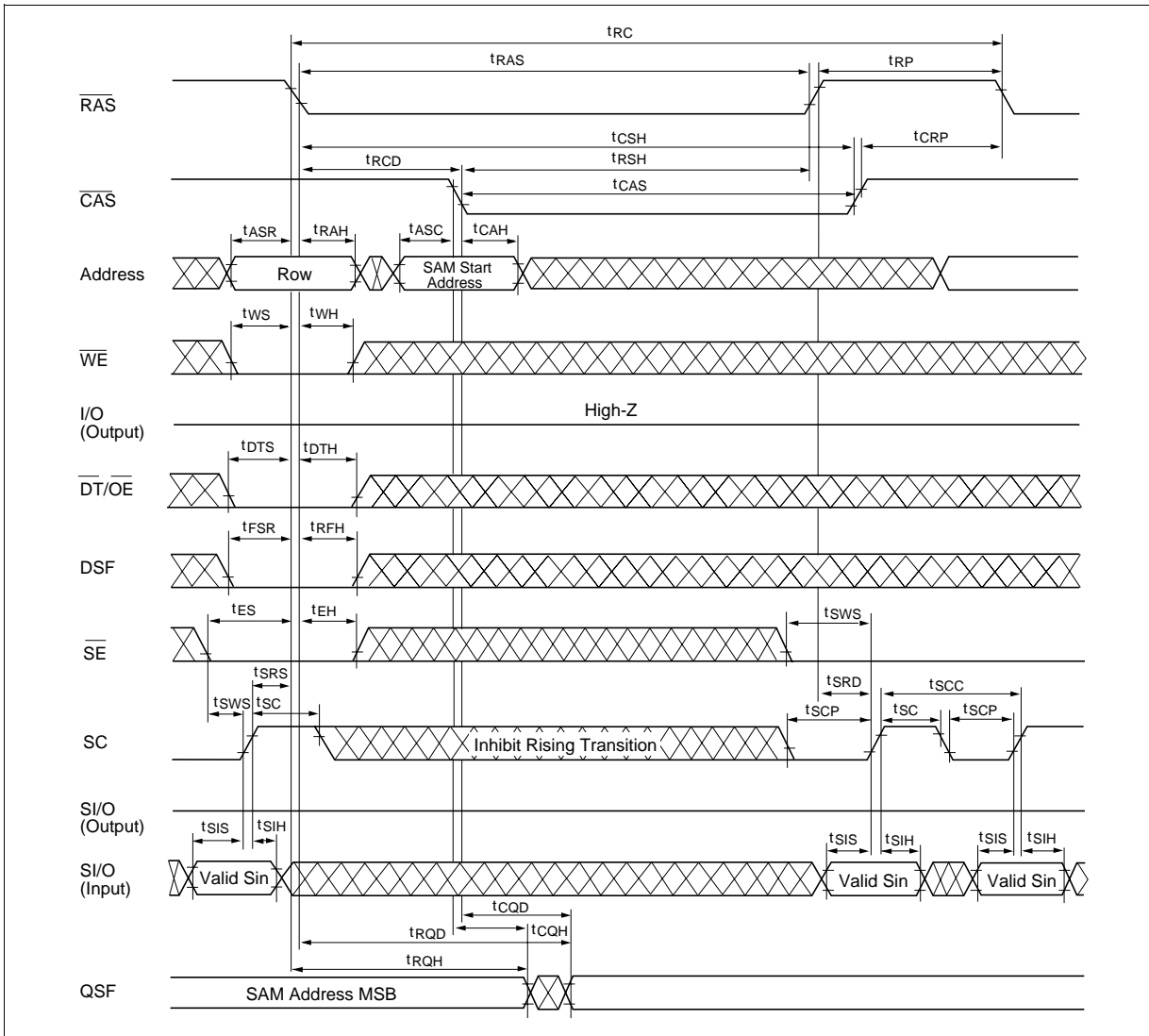

## Split Read Transfer Cycle

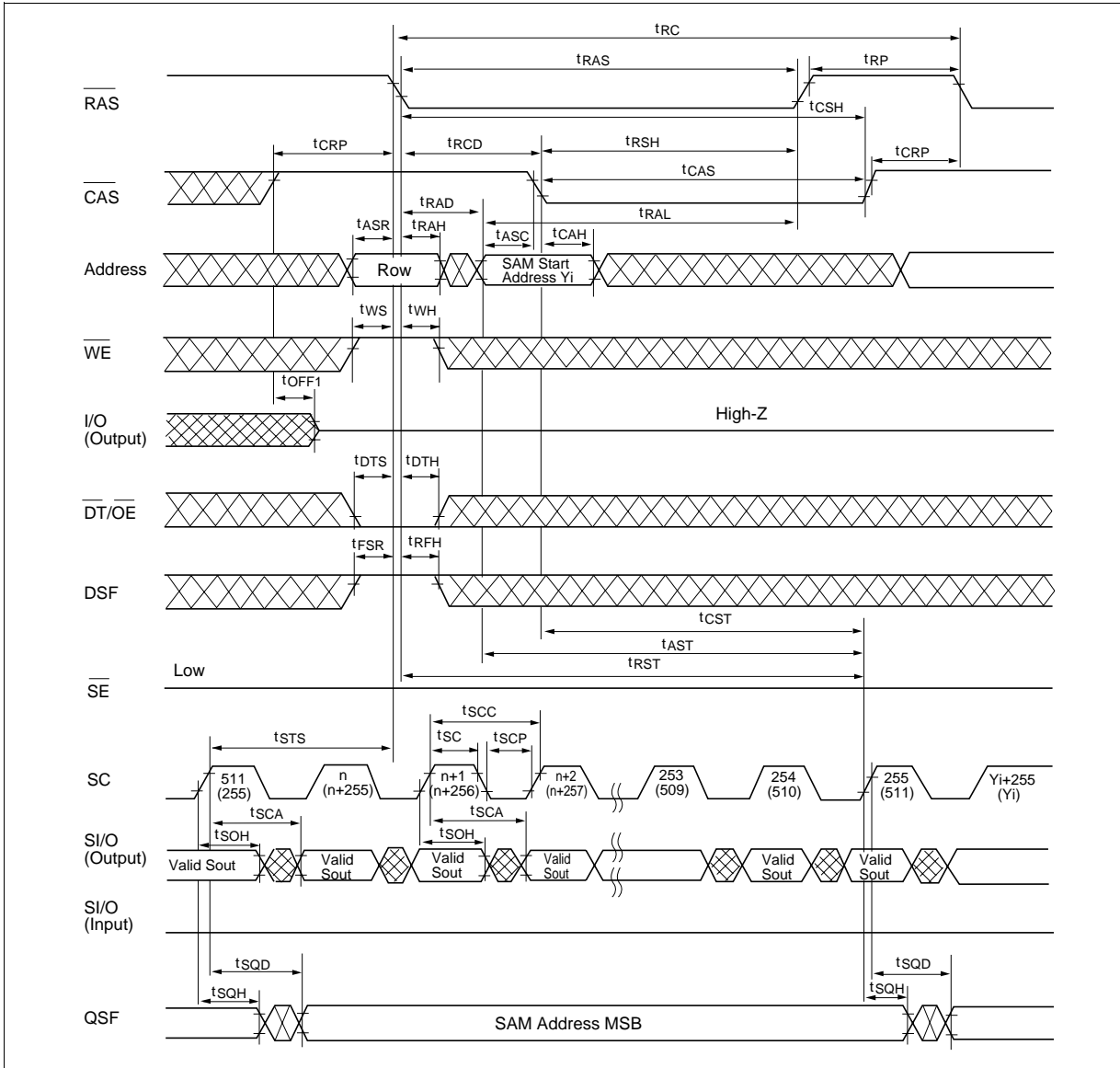



Split Write Transfer Cycle

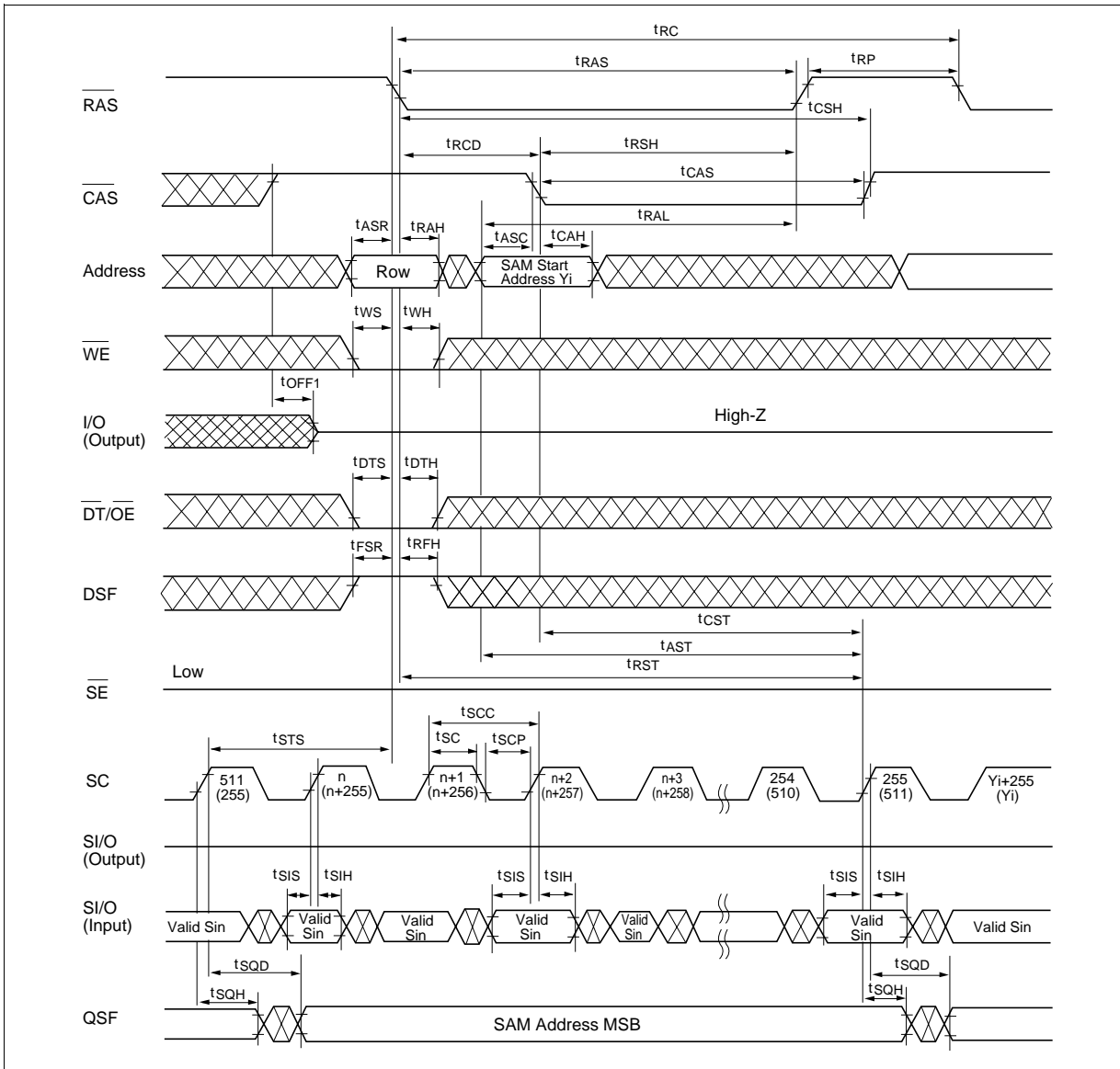

## Serial Read Cycle

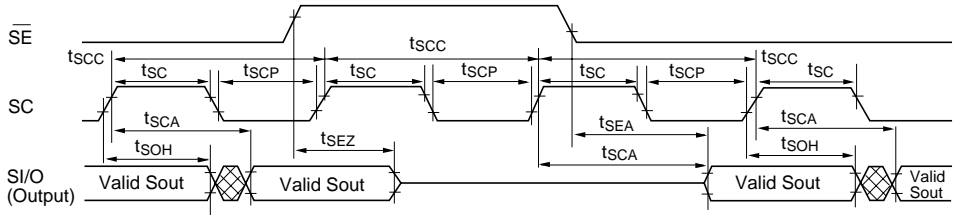

## Serial Write Cycle

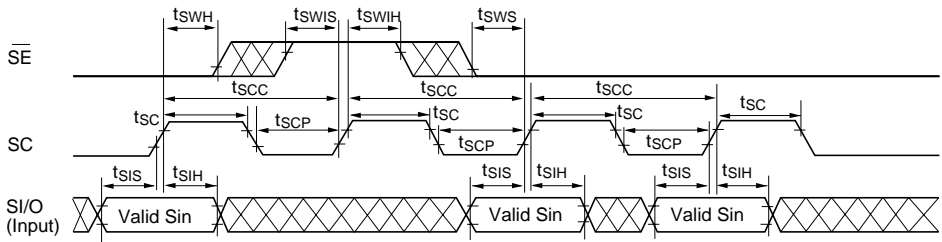

Package Dimensions

HM534253BJ Series (CP-28D)

Unit: mm

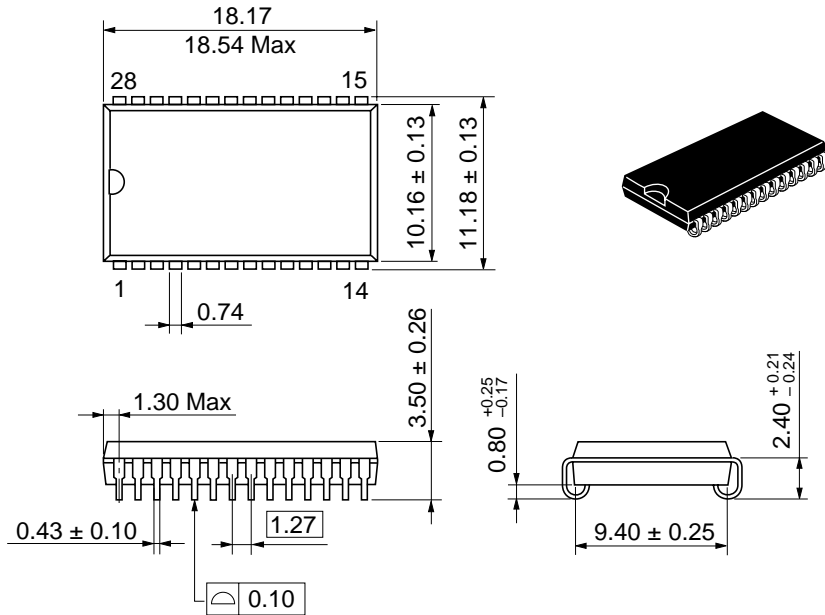

HM534253BZ Series (ZP-28)

Unit: mm

