

SANYO

No. 3935

LA7371A

Monolithic Linear IC

**Recording and Playback Amplifier
for VHS Video Recorders****OVERVIEW**

The LA7371A is a recording and playback amplifier for VHS-format video tape recorders. It incorporates a four-channel playback amplifier, making it ideal for applications that require slow motion playback, special effects and high quality picture-search.

The LA7371A features a constant-current output, a two-channel recording amplifier for stable operating characteristics, and an on-chip envelope detector and comparator for automatic tracking.

The LA7371A operates from a 5 V supply and is available in 24-pin DIPs.

FEATURES

- Four-channel playback amplifier
- Two-channel recording amplifier
- Automatic gain control
- On-chip envelope detector and comparator for automatic tracking
- 5 V supply
- 24-pin DIP

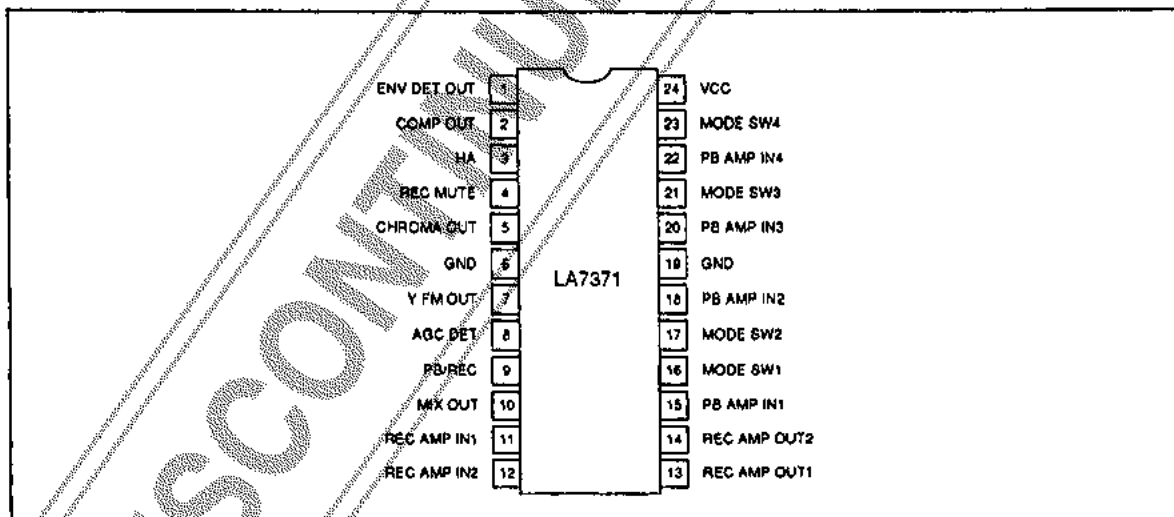
PINOUT

Specifications and information herein are subject to change without notice.

SANYO Electric Co., Ltd. Semiconductor Division
 Natsume Bldg., 18-6, 2-chome, Yushima, Bunkyo-ku, TOKYO 113 JAPAN

LA7371A

PACKAGE DIMENSIONS

Unit: mm

3067-DIP24S

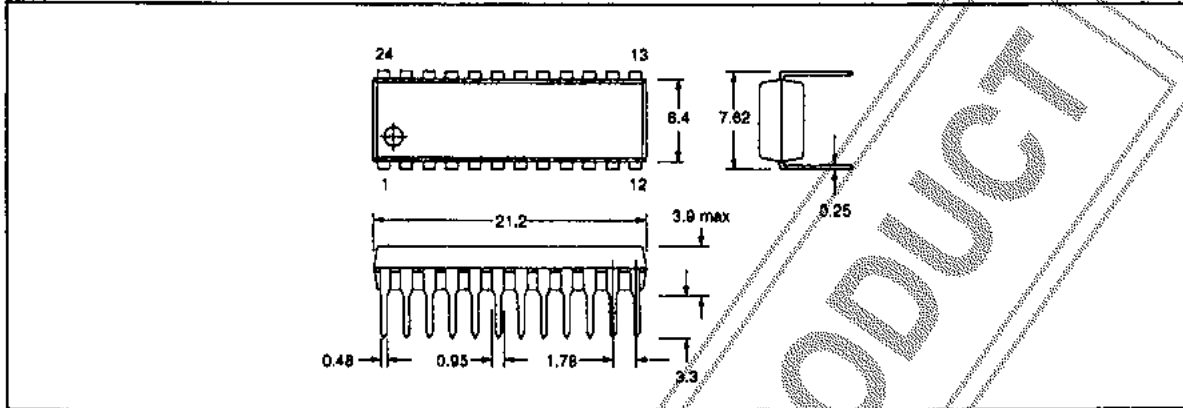

BLOCK DIAGRAM

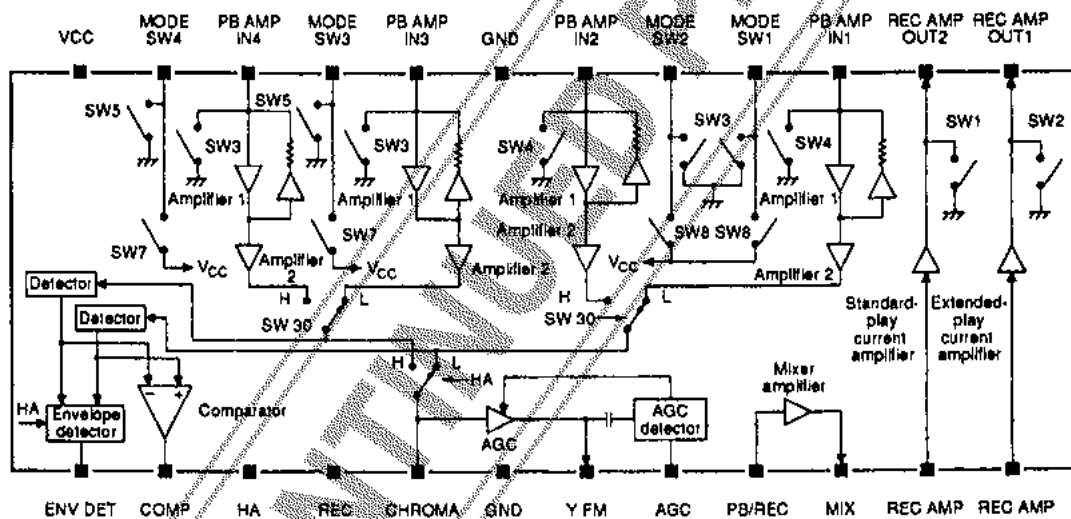

PIN DESCRIPTION

Number	Name	Equivalent circuit	Description
1	ENV DET OUT		Playback envelope detector output. Nominal voltages are 0.5 V (PB) and 0 V (REC).
2	COMP OUT		RF envelope comparator output. Nominal voltage is 0 V (PB and REC).

LA7371A

Number	Name	Equivalent circuit	Description
3	HA		Extended-play/standard-play control input
4	REC MUTE		Muting control input and playback SW30 switch
5	CHROMA OUT		Playback chrominance output and recording H control input. Nominal voltages are 2.0 V (PB) and > 3.8 V (REC).
6	GND		Ground
7	Y FM OUT		Playback luminance FM output. Nominal voltages are 2.5 V (PB) and 4.0 V (REC).
8	AGC DET.		Playback AGC detector output. Nominal voltages are 1.0 V (PB) and 0 V (REC).
9	PB/REC		Playback special-effects mode select control and recording mixer input. Nominal voltages are 2.1 V (PB) and 1.65 V (REC) and > 3.5 V (special). Gain is 12 dB when R = 2 kΩ, and 6 dB, when 3.9 kΩ.

LA7371A

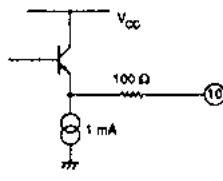
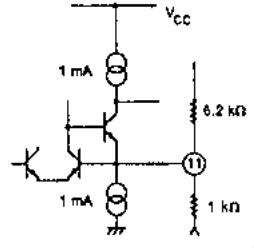
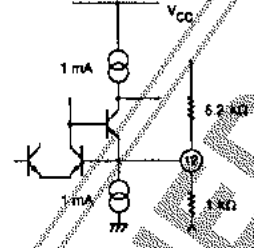
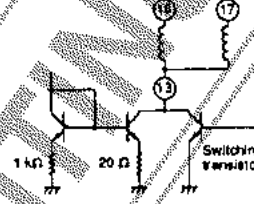
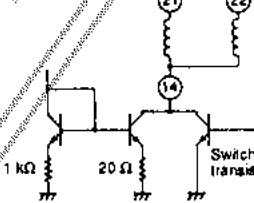
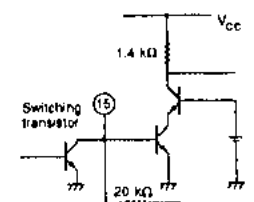
Number	Name	Equivalent circuit	Description
10	MIX OUT		Mixer amplifier output. Nominal voltages are 4.1 V (PB) and 1.8 V (REC).
11	REC AMP IN1		Recording amplifier inputs. Nominal voltages are 1.77 V (PB) and 1.85 V (REC).
12	REC AMP IN2		Recording amplifier inputs. Nominal voltages are 1.77 V (PB) and 1.85 V (REC).
13	REC AMP OUT1		Recording amplifier outputs. Nominal voltages are 0 V (PB) and 4.2 V (REC). Switching transistor ON resistance is 5 Ω.
14	REC AMP OUT2		Recording amplifier outputs. Nominal voltages are 0 V (PB) and 4.2 V (REC). Switching transistor ON resistance is 5 Ω.
15	PB AMP IN1		Playback preamplifier input. Nominal voltages are 0.7 V (PB) and 0 V (REC). Low-noise input transistor

LA7371A

Number	Name	Equivalent circuit	Description
16	MODE SW1		Recording-mode/playback-mode switch outputs. Nominal voltages are 0 V (PB) and 4.2 V (REC).
17	MODE SW2		
18	PB AMP IN2		Playback preamplifier input. Nominal voltages are 0.7 V (PB) and 0 V (REC). Low-noise input transistor.
19	GND		Preamplifier ground
20	PB AMP IN3		Playback preamplifier input. Nominal voltages are 0.7 V (PB) and 0 V (REC). Low-noise input transistor
21	MODE SW3		Recording-mode/playback-mode switch outputs. Nominal voltages are 0 V (PB) and 4.2 V (REC).
23	MODE SW4		
22	PB AMP IN4		Playback preamplifier input. Nominal voltages are 0.7 V (PB) and 0 V (REC). Low-noise input transistor
24	VCC		5 V supply

SPECIFICATIONS

Absolute Maximum Ratings

Parameter	Symbol	Rating	Unit
Supply voltage	V _{CC}	7.0	V
Power dissipation	P _D	850 (T _a = 65 °C)	mW
Operating temperature range	T _{OP}	-10 to 65	°C
Storage temperature range	T _{stg}	-40 to 150	°C

LA7371A

Recommended Operating Conditions

$T_a = 25\text{ }^\circ\text{C}$

Parameter	Symbol	Rating	Unit
Supply voltage	V_{CC}	5	V
Supply voltage range	V_{CC}	4.75 to 5.5	V

Electrical Characteristics

Playback mode

$V_{CC} = 5\text{ V}$, $T_a = 25\text{ }^\circ\text{C}$, SW2 is OFF

Parameter	Symbol	Condition	Rating			Unit
			min	typ	max	
Supply current	I_{CCP}		43	50	57	mA
Channel 1 standard-play mode voltage gain	G_{VP1}	$V_{IN} = 38\text{ mV}_{P-P}$ $f = 1\text{ MHz}$	54	56	58	dB
Channel 2 standard-play mode voltage gain	G_{VP2}		54	56	58	dB
Channel 3 extended-play mode voltage gain	G_{VP3}		55	57	59	dB
Channel 4 extended-play mode voltage gain	G_{VP4}		55	57	59	dB
Standard-play mode gain differential	ΔG_{VP1}	$G_{VP1} - G_{VP2}$	-1	0	1	dB
Extended-play gain differential	ΔG_{VP2}	$G_{VP3} - G_{VP4}$	-1	0	1	dB
Gain differential between modes	ΔG_{VP}	$G_{VP2} - G_{VP1}$	0	1	2	dB
Input conversion rms noise voltage	V_{NIN}	1.1 MHz lowpass filter	-	1.1	1.5	μV
Frequency response	ΔV_{fp}	$V_{IN} = 38\text{ mV}_{P-P}$ $f = 7\text{ MHz}$	-2.5	0	-	dB
Second-harmonic distortion	V_{HDP}	$V_{IN} = 38\text{ mV}_{P-P}$ $f = 4\text{ MHz}$	-	-33	-30	dB
Maximum output voltage	V_{OMP}	$f = 1\text{ MHz}$, -30 dB harmonic distortion	0.8	1.0	-	V_{P-P}
Standard-play mode and extended-play mode crosstalk	V_{CR}	8.2 μH input inductor short circuited	-	-40	-35	dB
Output DC offset voltage between channels	V_{ODC}		-300	0	300	mV
AGC output voltage	V_{AGC}	$f = 4\text{ MHz}$, $T_5 = 250\text{ mV}_{P-P}$	280	310	340	mV_{P-P}
AGC second-harmonic distortion	V_{HDAGC}	$V_{IN} = 38\text{ mV}_{P-P}$ $f = 4\text{ MHz}$	-	-35	-30	dB
AGC control level	ΔV_{AGC}	$f = 4\text{ MHz}$, $T_5 = 500\text{ mV}_{P-P}$	-	1.0	1.5	dB
		$f = 4\text{ MHz}$, $T_5 = 125\text{ mV}_{P-P}$	-1.2	-0.7	-	
Envelope detector quiescent output voltage	V_{ENVD}	T12 quiescent, no input	-	0.5	-	V

LA7371A

Parameter	Symbol	Condition	Rating			Unit
			min	typ	max	
Envelope detector output voltage	V_{ENV}	$f = 4 \text{ MHz}$, $T5 = 300 \text{ mV}_{p-p}$, $T12 = V_{CC} - V_{ENVO}$	2.6	2.9	3.2	V
		$f = 4 \text{ MHz}$, $T5 = 500 \text{ mV}_{p-p}$, $T12 = V_{CC} - V_{ENVO}$	3.0	3.2	3.4	
		$f = 3 \text{ MHz}$, $T5 = 300 \text{ mV}_{p-p}$, $T12 = V_{CC} - V_{ENVO}$	2.2	2.5	2.8	
		$f = 5 \text{ MHz}$, $T5 = 300 \text{ mV}_{p-p}$, $T12 = V_{CC} - V_{ENVO}$	2.7	3.0	3.3	
Standard-play mode comparator output voltage	V_{COMP1}	$V_{IN} = 38 \text{ mV}_{p-p}$, $f = 4 \text{ MHz}$	0	0.1	0.2	V
Extended-play mode comparator output voltage	V_{COMP2}		3.9	4.1	4.3	V

Recording mode

$V_{CC} = 5 \text{ V}$, $T_a = 25 \text{ }^\circ\text{C}$, SW2 is ON

Parameter	Symbol	Condition	Rating			Unit
			min	typ	max	
Supply current	I_{CCR}		60	65	70	mA
Standard-play mode voltage gain	G_{VRS}	$V_{IN} = 150 \text{ mV}_{p-p}$, $f = 4 \text{ MHz}$	-5	-3	-1	dB
Extended-play mode voltage gain	G_{VRE}		-5	-3	-1	dB
Gain differential between modes	ΔG_{VR}	$G_{VRE} - G_{VRS}$	-	0	-	dB
Standard-play mode frequency response	ΔV_{RS}	$V_{IN} = 150 \text{ mV}_{p-p}$, $f = 1 \text{ to } 7 \text{ MHz}$	-2.0	-0.5	-	dB
Extended-play mode frequency response	ΔV_{RE}		-2.0	-0.5	-	dB
Standard-play mode second-harmonic distortion	V_{HRS}	$V_{OUT} = 150 \text{ mV}_{p-p}$, $f = 4 \text{ MHz}$	-	-45	-40	dB
Extended-play mode second-harmonic distortion	V_{HRE}		-	-45	-40	dB
Standard-play mode output voltage	V_{OMPS}	$f = 4 \text{ MHz}$, -40 dB harmonic distortion	15	20	-	mV_{p-p}
Extended-play mode output voltage	V_{OMPE}					
Standard-play mode mixing attenuation	V_{MRS}	$V_{IN} = 150 \text{ mV}_{p-p}$, $f = 4 \text{ MHz}$	-	-45	-40	dB
Extended-play mode mixing attenuation	V_{MRE}		-	-45	-40	dB
Standard-play mode intermodulation distortion	V_{CYSP}	$f_{(T0)} = 4 \text{ MHz}$, $f_{(T0C)} = 629 \text{ kHz}$, $T16A = 150 \text{ mV}_{p-p}$, $T16 = 40 \text{ mV}_{p-p}$	-	-45	-40	dB
Extended-play mode intermodulation distortion	V_{CYEP}		-	-45	-40	dB
Luminance and chrominance mixer voltage gain	G_{MX}	$V_{IN} = 150 \text{ mV}_{p-p}$, $f = 4 \text{ MHz}$	8.5	10.5	12.5	dB

LA7371A

Switching transistors

 $V_{CC} = 5 \text{ V}$, $T_a = 25 \text{ }^\circ\text{C}$

Parameter	Symbol	Condition	Rating			Unit
			min	typ	max	
SW1 and SW2 ON resistance	R_{ON1}	Measured with 1 mA and 2 mA DC inputs	-	5	8	Ω
SW5 and SW6 ON resistance	R_{ON2}	Measured with 1 mA and 2 mA DC inputs	-	6	10	Ω
Recording/playback switch threshold voltage	SW_{REC}		3.8		5.0	V

Playback-mode threshold voltages

 $V_{CC} = 5 \text{ V}$, $T_a = 25\text{ }^\circ\text{C}$

Parameter	Symbol	Condition	Rating			Unit
			min	typ	max	
Trick H (pin 9) threshold voltage	TR	$T2 = 4 \text{ V}$	3.7	-	5.0	V
		$T2 = 0 \text{ V}$	-	-	3.3	
SW30 (pin 4) threshold voltage	$SW30_1$	Channel 1 to 2	1.2	-	5.0	V
	$SW30_2$	Channel 2 to 1	0	-	0.8	
HA (pin 3) threshold voltage	HA_{P1}	Channel 1 to 3	2.7	-	5.0	V
	HA_{P2}	Channel 3 to 1	0	-	2.3	V

Recording-mode threshold voltages

 $V_{CC} = 5 \text{ V}$, $T_a = 25\text{ }^\circ\text{C}$

Parameter	Symbol	Condition	Rating			Unit
			min	typ	max	
HA REC (pin 3) HIGH-level threshold voltage	HA_{R1}		2.7	-	5.0	V
HA REC (pin 3) LOW-level threshold voltage	HA_{R2}		0	-	2.3	V
MUTE HIGH-level threshold voltage	$MUTE_1$		3.7	-	5.0	V
MUTE LOW-level threshold voltage	$MUTE_2$		0	-	3.3	V

Measurement Condition Internal Switch Positions

Playback mode

Parameter	Channel	Test points		Switch positions				
		Input	Output	TR	RP	3D	MU	HA
Supply current		VCC		F	F	F	F	F
Voltage gain, input conversion noise voltage, frequency response, harmonic distortion and maximum output level	1	T15	T5	F	F	F	F	F
	2	T18	T5	F	F	F	F	F
	3	T20	T5	F	F	N	F	F
	4	T23	T5	F	F	N	F	N
Standard-play mode crosstalk	1	T18, T20, T23	T5	N	F	F	F	F
	2	T15, T20, T23	T5	N	F	N	F	F
Extended-play mode crosstalk	3	T15, T18, T23	T5	N	F	F	F	N
	4	T15, T18, T20	T5	N	F	N	F	N
Output DC offset voltage	1 to 2		CHROMA OUT	N	F	×	F	F
	3 to 4		CHROMA OUT	N	F	×	F	N
	1 to 3		CHROMA OUT	N	F	F	F	×
	2 to 4		CHROMA OUT	N	F	N	F	×
	1 to 4		CHROMA OUT	N	F	×	F	×
	2 to 3		CHROMA OUT	N	F	×	F	×
AGC measurements		T15	T7	F	F	F	F	F
Envelope detector quiescent output			T1	F	F	F	F	F
Envelope detector output voltage		T15	T1	F	F	F	F	F
V _{COMP1} comparator output voltage		T15	T2	N	F	F	F	F
V _{COMP2} comparator output voltage		T20	T2	N	F	F	F	N

Note

× = don't care

Recording mode

Parameter	Channel	Test points		Switch positions				
		Input	Output	TR	RP	3D	MU	HA
Supply current		VCC		F	N	F	F	F
Gain, gain differential, frequency response, harmonic distortion, output level	1, 2	T16		F	N	F	F	F
	3, 4		T21	F	N	F	F	N

LA7371A

Parameter	Channel	Test points		Switch positions				
		Input	Output	TR	RP	3D	MU	HA
Muting attenuation	1, 2	T9Y	T16	F	N	F	N	F
	3, 4	T9Y	T21	F	N	F	N	N
Intermodulation distortion	1, 2	T9Y, T9C	T16	F	N	F	F	F
	3, 4	T9Y, T9C	T21	F	N	F	F	N
Luminance and chrominance mixer voltage gain		T9Y	T10	F	N	F	F	×

Note

× = don't care

Switching transistors

Parameter	Channel	Test points		Switch positions				
		Input	Output	TR	RP	3D	MU	HA
Playback mode switching-transistor ON resistance	1, 2		REC AMP OUT2	×	F	×	×	×
	3, 4		REC AMP OUT1	×	F	×	×	×
	1		MODE SW1	F	F	×	×	N
	2		MODE SW2	F	F	×	×	N
	3		MODE SW3	F	F	×	×	N
	4		PB AMP IN4	F	F	×	×	F
Recording mode switching-transistor ON resistance	1, 2		REC AMP OUT2	×	N	×	×	N
	3, 4		REC AMP OUT1	×	N	×	×	F
	1, 2		MODE SW1 and MODE SW2	×	N	×	F	N
	3, 4		PB AMP IN4	×	N	×	×	N

Note

× = don't care

Threshold voltages

Parameter	Channel	Test points		Switch positions				
		Input	Output	TR	RP	3D	MU	HA
Special-effects mode threshold voltage	1, 2, 3, 4	T20	T2	×	F	F	F	×
SW30 threshold voltage	1, 2, 3, 4	T15, T18	T5	×	F	×	F	F
HA playback-mode threshold voltage	1, 2, 3, 4	T15, T20	T5	F	F	F	F	×
Muting threshold voltage	1, 2, 3, 4	T9Y	T10	×	N	×	×	×
HA recording-mode threshold voltage	1, 2, 3, 4	T9Y	T21	×	N	×	F	×

Note

× = don't care

Mode Selection

Mode	HA	Playback ON-transistor switches		Playback amplifier control switches		Head short-circuit switches		Recording drive current	
		SW1	SW2	SW3	SW4	SW5	SW6	SW7	SW8
Recording	SP	LOW	OFF	ON	ON	ON	OFF	OFF	ON
	EP	HIGH	ON	OFF	ON	ON	ON	ON	OFF
Playback	SP	LOW	ON	ON	OFF	ON	OFF	OFF	OFF
	EP	HIGH	ON	ON	OFF	ON	OFF	OFF	OFF
	Trick	HIGH	ON	ON	OFF	OFF	OFF	OFF	OFF

Note

HA is HIGH when greater than 2.5 V.

TYPICAL APPLICATION

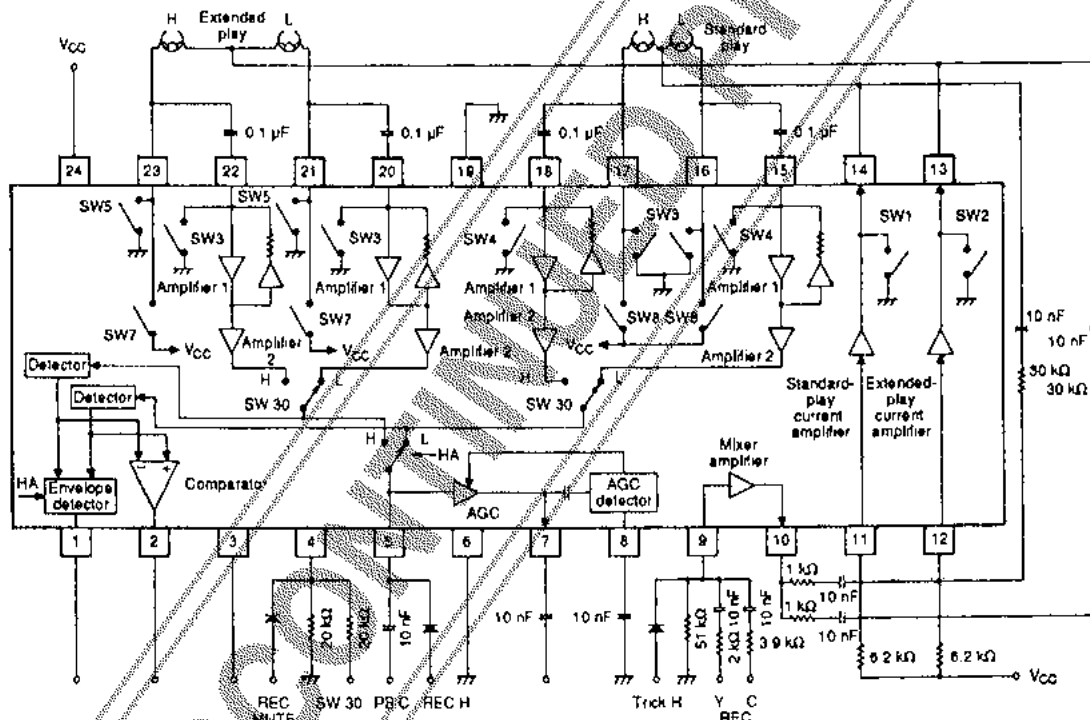

Figure 1. Tape head amplifier

Information (including circuit diagrams and circuit parameters) herein is for example only; it is not guaranteed for volume production. SANYO believes information herein is accurate and reliable, but no guarantees are made or implied regarding its use or any infringements of intellectual property rights or other rights of third parties.