

**GENERAL DESCRIPTION**

The BM9131 family is a positive voltage linear regulator developed utilizing CMOS technology featured low quiescent current (40  $\mu$  A typ.), low dropout voltage, and high output voltage accuracy, making them ideal for battery applications. EN input connected to CMOS has low bias current. The space-saving SOT-23-5 package is attractive for “Pocket” and “Hand Held” applications.

These rugged devices have both Thermal Shutdown, and Current Fold-back to prevent device failure under the “Worst” of operating conditions.

In application requiring a low noise, regulated supply, place a 1000pF capacitor between Bypass and Ground.

The BM9131 is stable with an output capacitance of 2.2  $\mu$  F or greater.

**FEATURES**

- ◆ Good Noise Rejection : 62dB
- ◆ Very Low Dropout Voltage , 0.2V@70mA
- ◆ Low Current Consumption: Typ. 30  $\mu$  A, Max. 50  $\mu$  A
- ◆ Extra low shutdown current: 0.1uA
- ◆ Output Voltage: 1.8V, 2.5V , 2.8V, 3.0V, 3.3V
- ◆ High Accuracy Output Voltage: +/- 1.5%
- ◆ Fast enable start up (turn on time) : 20us
- ◆ Guaranteed 150mA Output
- ◆ Input Range up to 7.0V
- ◆ Thermal Shutdown
- ◆ Current Limiting
- ◆ Compact Package: SOT-23-5
- ◆ Factory Pre-set Output Voltages
- ◆ Short Circuit Current Fold-Back
- ◆ Low Temperature Coefficient

**APPLICATIONS**

- ◆ Battery-powered devices
- ◆ Personal communication devices
- ◆ Home electric/electronic appliances
- ◆ PC peripherals

**TYPICAL APPLICATIONS**

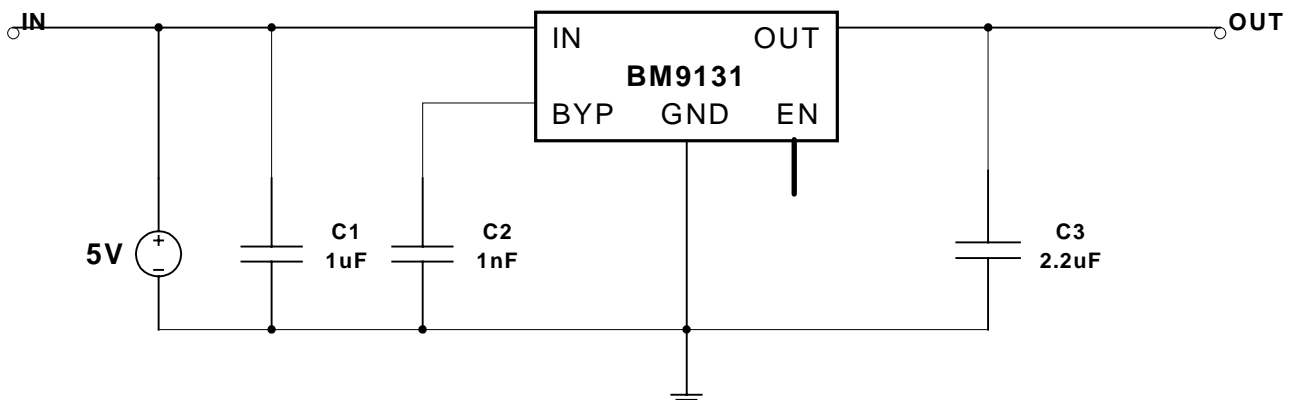

**PIN CONFIGURATION**

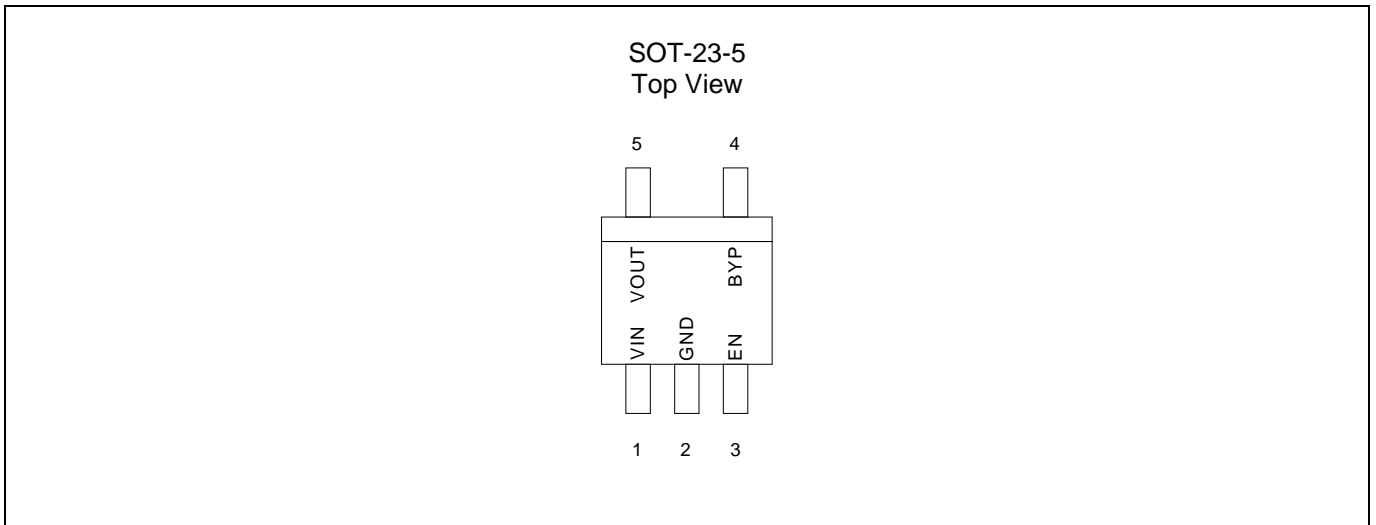

**BLOCK DIAGRAM**

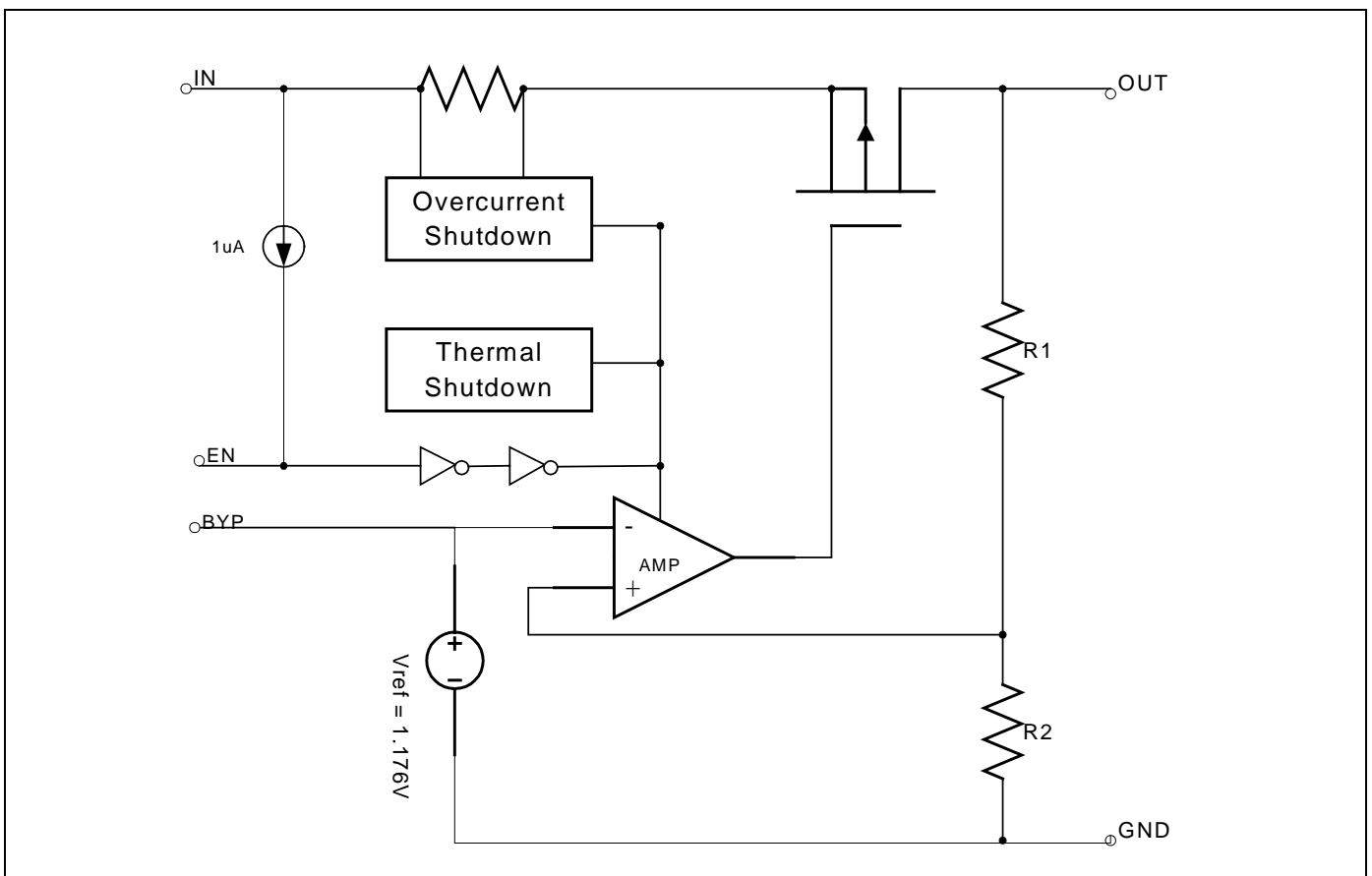

**ORDERING INFORMATION**

Part Number	Output Voltage	Temperature Range	Package
BM9131DIM25	1.8V	-40°C ~ +85°C	SOT-23-5
BM9131KIM25	2.5V	-40°C ~ +85°C	SOT-23-5
BM9131NIM25	2.8V	-40°C ~ +85°C	SOT-23-5
BM9131PIM25	3.0V	-40°C ~ +85°C	SOT-23-5
BM9131SIM25	3.3V	-40°C ~ +85°C	SOT-23-5

Note: For other pre-set output voltage requirements, please contact Bookly Sales office.

**ABSOLUTE MAXIMUM RATINGS**

Input Voltage ..... +7V  
 Output Current .....  $P_D / (V_{IN} - V_o)$  mA  
 Output Voltage ..... GND-0.3V to  $V_{IN}+0.3V$   
 ESD Classification ..... B

**OPERATING RATINGS**

Ambient Temperature Range ( $T_A$ ) ..... -40°C to +85°C  
 Junction Temperature Range ..... -40°C to +125°C

**THERMAL INFORMATION**

Parameter		Maximum	Unit
Thermal Resistance ( $\theta_{jc}$ )	SOT-23-5	160	°C/W
Internal Power Dissipation ( $P_D$ ) ( $\Delta T = 100^\circ\text{C}$ )	SOT-23-5	320	°C/W
Maximum Junction Temperature		150	°C
Maximum Lead Temperature (10 Sec)		300	°C

Caution: Stress above the listed absolute rating may cause permanent damage to the device.

**ELECTRICAL CHARACTERISTICS**

T<sub>A</sub> = +25°C; unless otherwise noted

Parameter	Symbol	Test Conditions	BM9131			Unit
			Min.	Typ.	Max.	
Input Voltage	V <sub>IN</sub>		<b>Note 1</b>		7	V
Output Voltage Accuracy	V <sub>OUT</sub>	I <sub>O</sub> = 1mA	-1.5		1.5	%
Dropout Voltage	V <sub>DROPOUT</sub>	I <sub>O</sub> = 150mA, V <sub>OUT</sub> =V <sub>O(NOM)</sub> -2%,	1.2V<V <sub>O(NOM)</sub> <=2.0V		400	mV
			2.0V<V <sub>O(NOM)</sub> <=2.5V		300	
			2.5V<V <sub>O(NOM)</sub>		300	mV
Output Current	I <sub>O</sub>	V <sub>OUT</sub> > 1.2V	150			mA
Current Limit	I <sub>LIM</sub>	V <sub>OUT</sub> > 1.2V			400	mA
Short Circuit Current	I <sub>SC</sub>	V <sub>OUT</sub> < 0.95V		150	300	mA
Quiescent Current	I <sub>Q</sub>	I <sub>O</sub> = 0mA		30	50	μA
Ground Pin Current	I <sub>GND</sub>	I <sub>O</sub> = 1mA to 150mA		30	50	μA
Line Regulation	REG <sub>LINE</sub>	I <sub>OUT</sub> =5mA, V <sub>IN</sub> =V <sub>OUT</sub> +1 to V <sub>OUT</sub> +2		0.02	0.1	%
Load Regulation	REG <sub>LOAD</sub>	I <sub>O</sub> =1mA to 150mA		0.2	1	%
Over Temperature Shutdown	OTS			150		°C
Over Temperature Hysteresis	OTH			30		°C
V <sub>OUT</sub> Temperature Coefficient	TC			40		ppm/°C
Power Supply Rejection	PSRR	I <sub>O</sub> = 100mA C <sub>O</sub> =2.2 μ F ceramic	f=1kHz		62	dB
			f=10kHz		55	
			f=100kHz		45	
Power Supply Rejection	PSRR	I <sub>O</sub> = 100mA C <sub>O</sub> =2.2 μ F ceramic C <sub>BYP</sub> =0.1 μ F	f=1kHz		75	dB
			f=10kHz		62	
			f=100kHz		40	
Output Voltage Noise	eN	f=10Hz to 100kHz I <sub>O</sub> = 10mA, C <sub>BYP</sub> =0 μ F	C <sub>O</sub> =2.2 μ F		30	μ Vrms
			C <sub>O</sub> =100 μ F		20	
Output Voltage Noise	eN	f=10Hz to 100kHz I <sub>O</sub> = 10mA, C <sub>BYP</sub> =0.01 μ F	C <sub>O</sub> =2.2 μ F		30	μ Vrms
			C <sub>O</sub> =100 μ F		20	
Shutdown Supply Current	I <sub>SD</sub>	V <sub>IN</sub> =5.0V, V <sub>OUT</sub> =0V, V <sub>EN</sub> < V <sub>EL</sub>		0.1	1	μA
EN Input Bias Current	I <sub>EH</sub>	V <sub>EN</sub> =V <sub>IN</sub> , V <sub>IN</sub> =2.6V to 7V			0.1	μA
	I <sub>EL</sub>	V <sub>EN</sub> =0, V <sub>IN</sub> =2.6V to 7V		0.1	1	μA
EN Input Threshold	V <sub>EH</sub>	V <sub>IN</sub> =2.6V to 7V	<b>(Note2)</b>		V <sub>IN</sub>	V
	V <sub>EL</sub>	V <sub>IN</sub> =2.6V to 7V	0		0.4	V

**Note 1.** V<sub>IN(MIN)</sub> = V<sub>OUT</sub> + V<sub>DROPOUT</sub>

**Note 2.** Based on our design architecture, the enable input threshold will depend on the input voltage. To ensure the stability of your design application, please set the V<sub>EH(MIN)</sub> = V<sub>IN</sub>/2 + 0.8V.

## DETAILED DESCRIPTION

The BM9131 family of CMOS regulators contain a PMOS pass transistor, voltage reference, error amplifier, over-current protection, thermal shutdown, and short circuit protection.

The P-channel pass transistor receives data from the error amplifier, over-current shutdown, short output protection, and thermal protection circuits. During normal operation, the error amplifier compares the output voltage to a precision reference. Over-current and Thermal shutdown circuits become active when the junction temperature exceeds 150°C, or the current exceeds 150mA. During thermal shutdown, the output voltage remains low. Normal operation is restored when the junction temperature drops below 120°C.

The BM9131 switches from voltage mode to current mode when the load exceeds the rated output current. This prevents over-stress. The BM9131 also incorporates current fold-back to reduce power dissipation when the output is short-circuited. This feature becomes active when the output drops below 1.05V, and reduces the current flow by 65%. Full current is restored when the voltage exceeds 0.95V.

## ENABLE

The Enable pin normally floats high. When actively, pulled low, the PMOS pass transistor shut off, and all internal circuits are powered down. In this state, the quiescent current is less than 0.1  $\mu$  A. This pin behaves much like an electronic switch.

## EXTERNAL CAPACITOR

The BM9131 is stable with an output capacitor to ground of 2.2  $\mu$  F or greater. It can keep stable even with higher or poor ESR capacitors. A second capacitor is recommended between the input and ground to stabilize VIN. The input capacitor should be larger than 0.1  $\mu$  F to have a beneficial effect. All capacitors should be placed in close proximity to the pins. A “quiet” ground termination is desirable.

TYPICAL ELECTRICAL CHARACTERISTICS

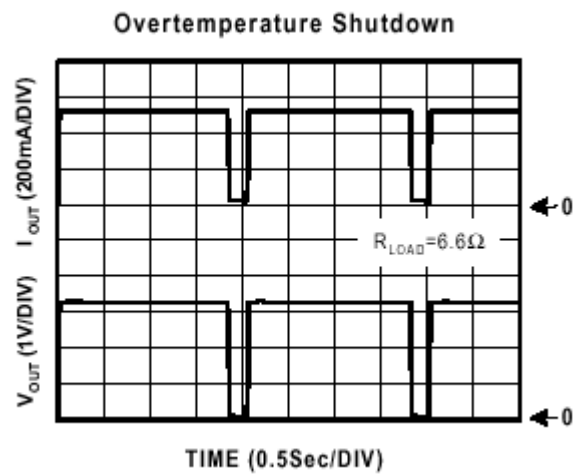
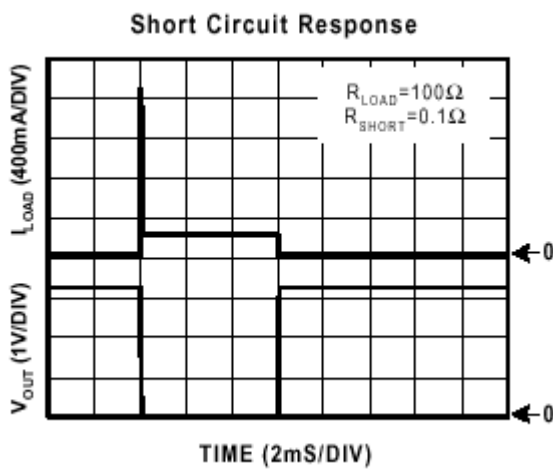
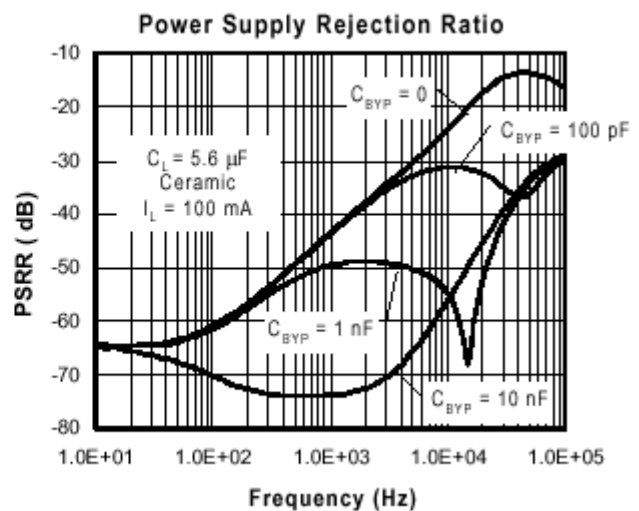
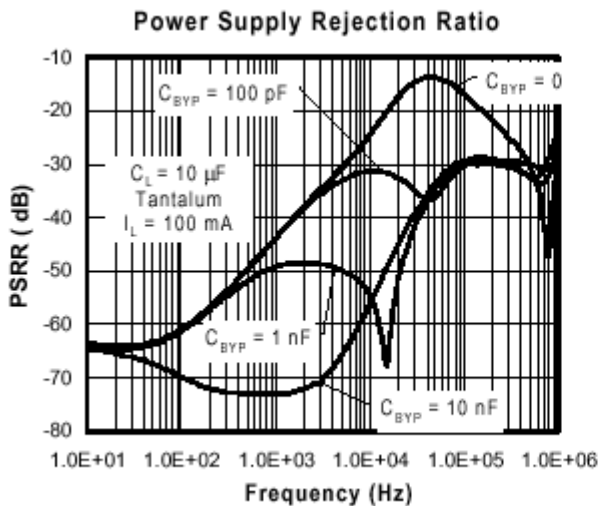
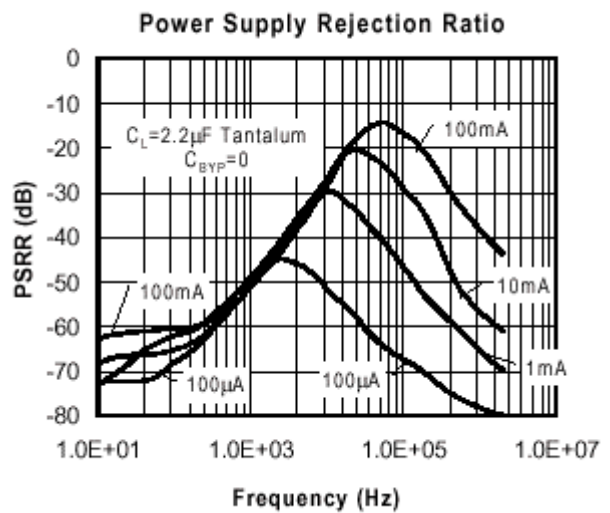
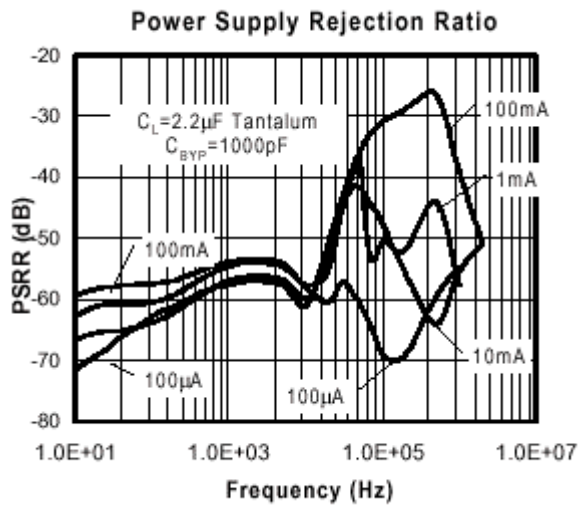

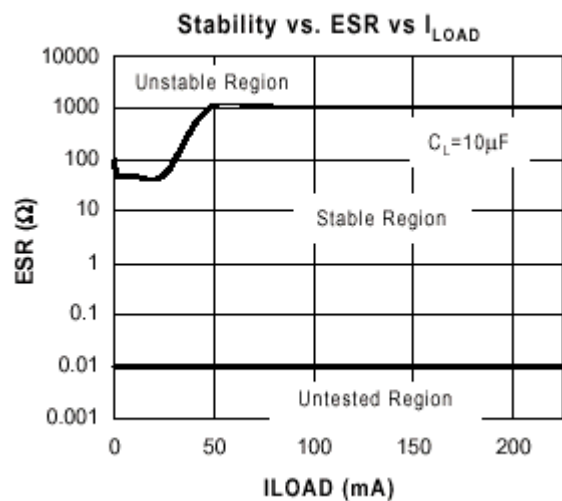
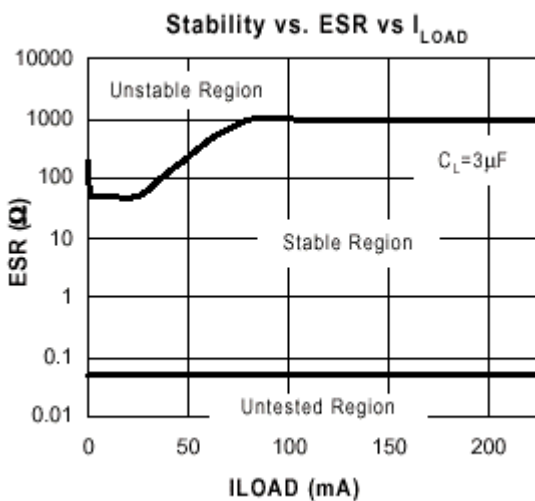
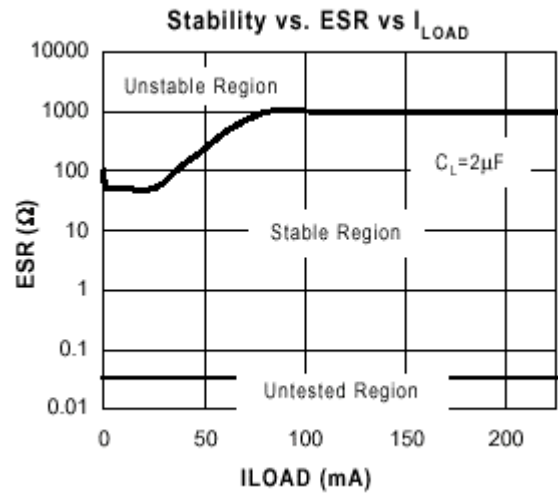
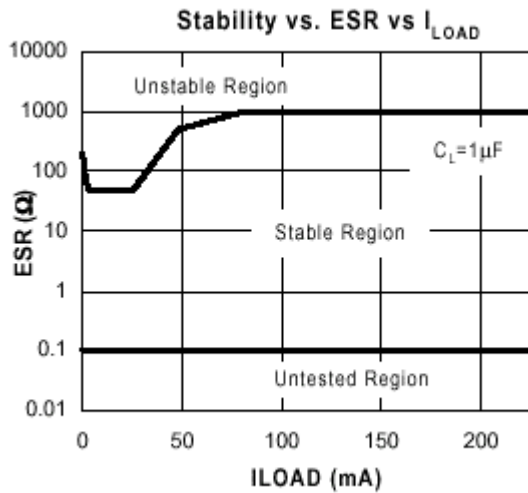
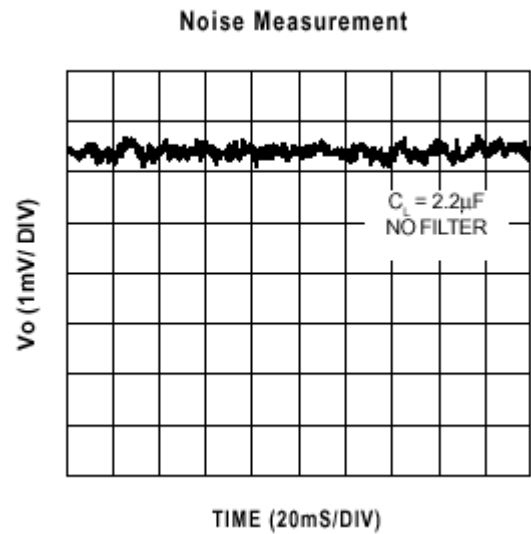
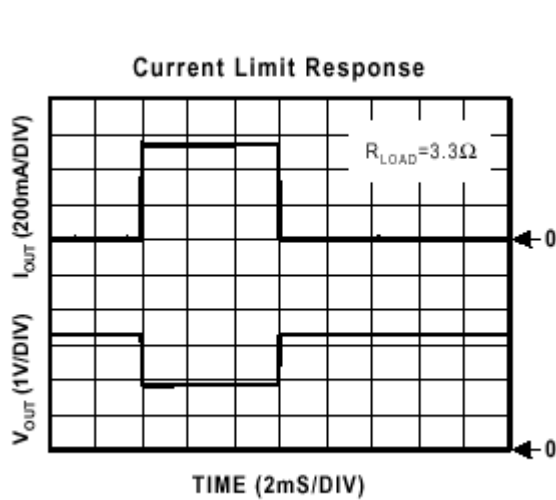

**PACKAGE DIMENSION**

**SOT-23-5 (M25)**

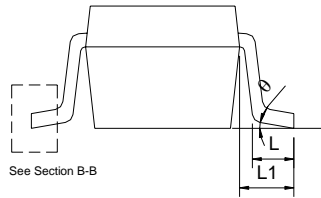
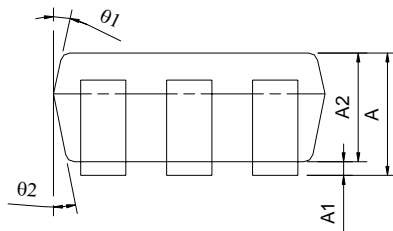
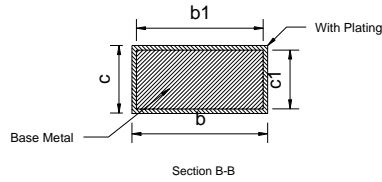
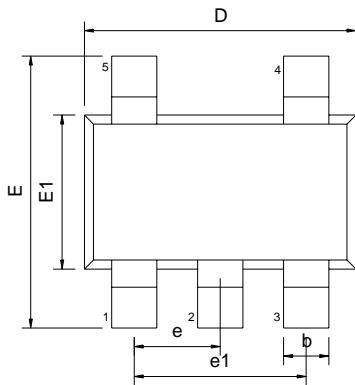

SYMBOLS	DIMENSIONS IN MILLIMETERS			DIMENSIONS IN INCHES		
	MIN	NOM	MAX	MIN	NOM	MAX
A	1.05	---	1.35	0.041	---	0.053
A1	0.05	---	0.15	0.002	---	0.006
A2	1.00	1.10	1.20	0.039	0.043	0.047
b	0.25	---	0.50	0.010	---	0.020
b1	0.25	0.40	0.45	0.010	0.016	0.018
c	0.08	---	0.20	0.003	---	0.008
c1	0.08	0.11	0.15	0.003	0.004	0.006
D	2.70	2.90	3.00	0.106	0.114	0.118
E	2.60	2.80	3.00	0.102	0.110	0.118
E1	1.50	1.60	1.70	0.059	0.063	0.067
L	0.35	0.45	0.55	0.014	0.018	0.022
L1	0.60 REF			0.024 REF		
e	0.95 BSC			0.037 BSC		
e1	1.90 BSC			0.075 BSC		
theta	0°	5°	10°	0°	5°	10°
theta1	3°	5°	7°	3°	5°	7°
theta2	6°	8°	10°	6°	8°	10°