

# MODEL HM66 SERIES

## Miniature

## Low Profile, Shielded Surface Mount Inductors

NEW PRODUCT

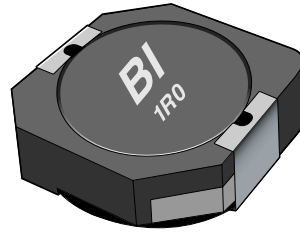

### FEATURES AND BENEFITS

- Very low profile, 1.8 mm to 4.0 mm
- Magnetic shielded construction for high density board assembly
- 1  $\mu$ H to 330  $\mu$ H inductance range
- Up to 10 amps continuous
- Designed for machine placement
- Compatible with vapor phase and infrared reflow soldering

### APPLICATIONS

- Wireless and PDAs
- PCMCIA cards and disk drives
- Inductor for space limited design

### ELECTRICAL / ENVIRONMENTAL

Operating Temperature Range	-25°C to +125°C
Storage Temperature Range	-40°C to +85°C
Ambient Temperature, Maximum	80°C
Insulation System	Class B, 130°C
Temperature Rise, Maximum	40°C

Specifications subject to change without notice.  
Last Update: 03/05/2003.

## SPECIFICATIONS

Part Number	Inductance Nominal $\mu\text{H} \pm 20\%$	DC Resistance $\Omega$ Max.	Rated Current Amps	Figure
HM66-101R5	1.5	0.055	1.55	1
HM66-102R2	2.2	0.072	1.20	1
HM66-103R3	3.3	0.085	1.10	1
HM66-104R7	4.7	0.105	0.90	1
HM66-106R8	6.8	0.170	0.73	1
HM66-10100	10	0.210	0.55	1
HM66-10150	15	0.295	0.45	1
HM66-10220	22	0.430	0.40	1
HM66-10330	33	0.675	0.32	1
HM66-151R5	1.5	0.055	1.55	2
HM66-152R2	2.2	0.072	1.20	2
HM66-153R3	3.3	0.085	1.10	2
HM66-154R7	4.7	0.105	0.90	2
HM66-156R8	6.8	0.170	0.73	2
HM66-15100	10	0.210	0.55	2
HM66-15150	15	0.295	0.45	2
HM66-15220	22	0.430	0.40	2
HM66-15330	33	0.675	0.32	2
HM66-201R0	1.0	0.045	1.72	2
HM66-202R2	2.2	0.075	1.32	2
HM66-202R7	2.7	0.105	1.28	2
HM66-203R3	3.3	0.110	1.04	2
HM66-203R9	3.9	0.155	0.88	2
HM66-204R7	4.7	0.162	0.84	2
HM66-205R6	5.6	0.170	0.80	2
HM66-206R8	6.8	0.200	0.76	2
HM66-208R2	8.2	0.245	0.68	2
HM66-20100	10	0.200	0.61	2
HM66-20120	12	0.210	0.56	2
HM66-20150	15	0.240	0.50	2
HM66-20180	18	0.338	0.48	2
HM66-20220	22	0.397	0.41	2
HM66-20270	27	0.441	0.35	2
HM66-20330	33	0.694	0.32	2
HM66-20390	39	0.709	0.30	2
HM66-301R2	1.2	0.0236	2.56	2
HM66-301R8	1.8	0.0275	2.20	2
HM66-302R2	2.2	0.0313	2.04	2
HM66-302R7	2.7	0.0433	1.60	2
HM66-303R3	3.3	0.0492	1.57	2
HM66-303R9	3.9	0.0648	1.44	2
HM66-304R7	4.7	0.0720	1.32	2
HM66-305R6	5.6	0.1009	1.17	2
HM66-306R8	6.8	0.1089	1.12	2

## SPECIFICATIONS

Part Number	Inductance Nominal $\mu\text{H} \pm 20\%$	DC Resistance $\Omega$ Max.	Rated Current Amps	Figure
HM66-308R2	8.2	0.1175	1.04	2
HM66-30100	10	0.1283	1.00	2
HM66-30120	12	0.1316	0.84	2
HM66-30150	15	0.1490	0.76	2
HM66-30180	18	0.1660	0.72	2
HM66-30220	22	0.2350	0.70	2
HM66-30270	27	0.2610	0.58	2
HM66-30330	33	0.378	0.56	2
HM66-30390	39	0.3837	0.50	2
HM66-30470	47	0.5870	0.48	2
HM66-30560	56	0.6245	0.41	2
HM66-30680	68	0.6990	0.35	2
HM66-30820	82	0.9148	0.32	2
HM66-30101	100	1.020	0.29	2
HM66-30121	120	1.270	0.27	2
HM66-30151	150	1.350	0.24	2
HM66-30181	180	1.540	0.22	2
HM66-404R1	4.1	0.057	1.95	2
HM66-405R4	5.4	0.076	1.60	2
HM66-406R2	6.2	0.096	1.40	2
HM66-408R9	8.9	0.116	1.25	2
HM66-40100	10	0.124	1.20	2
HM66-40120	12	0.153	1.10	2
HM66-40150	15	0.196	0.97	2
HM66-40180	18	0.210	0.85	2
HM66-40220	22	0.290	0.80	2
HM66-40270	27	0.330	0.75	2
HM66-40330	33	0.386	0.65	2
HM66-40390	39	0.520	0.57	2
HM66-40470	47	0.595	0.54	2
HM66-40560	56	0.665	0.50	2
HM66-40680	68	0.840	0.43	2
HM66-40820	82	0.978	0.41	2
HM66-40101	100	1.200	0.36	2
HM66-502R5	2.5	0.018	2.60	2
HM66-503R0	3.0	0.024	2.40	2
HM66-504R2	4.2	0.031	2.20	2
HM66-505R3	5.3	0.038	1.90	2
HM66-506R2	6.2	0.045	1.80	2
HM66-508R2	8.2	0.053	1.60	2
HM66-50100	10	0.065	1.30	2
HM66-50120	12	0.076	1.20	2
HM66-50150	15	0.103	1.10	2
HM66-50180	18	0.110	1.00	2

## SPECIFICATIONS

Part Number	Inductance Nominal $\mu\text{H} \pm 20\%$	DC Resistance $\Omega$ Max.	Rated Current Amps	Figure
HM66-50220	22	0.122	0.90	2
HM66-50270	27	0.175	0.85	2
HM66-50330	33	0.189	0.75	2
HM66-50390	39	0.212	0.70	2
HM66-50470	47	0.260	0.62	2
HM66-50560	56	0.305	0.58	2
HM66-50680	68	0.355	0.52	2
HM66-50820	82	0.463	0.46	2
HM66-50101	100	0.520	0.42	2
HM66-603R0	3.0	0.024	3.00	2
HM66-603R9	3.9	0.027	2.60	2
HM66-605R0	5.0	0.031	2.40	2
HM66-606R0	6.0	0.035	2.25	2
HM66-607R3	7.3	0.054	2.10	2
HM66-608R6	8.6	0.058	1.85	2
HM66-60100	10	0.065	1.70	2
HM66-60120	12	0.070	1.55	2
HM66-60150	15	0.084	1.40	2
HM66-60180	18	0.095	1.32	2
HM66-60220	22	0.128	1.20	2
HM66-60270	27	0.142	1.05	2
HM66-60330	33	0.165	0.97	2
HM66-60390	39	0.210	0.86	2
HM66-60470	47	0.238	0.80	2
HM66-60560	56	0.277	0.73	2
HM66-60680	68	0.304	0.65	2
HM66-60820	82	0.390	0.60	2
HM66-60101	100	0.535	0.54	2
HM66-703R3	3.3	0.020	3.50	2
HM66-705R0	5.0	0.024	2.90	2
HM66-706R2	6.2	0.027	2.50	2
HM66-707R4	7.4	0.031	2.30	2
HM66-708R7	8.7	0.034	2.20	2
HM66-70100	10	0.038	2.00	2
HM66-70120	12	0.053	1.70	2
HM66-70150	15	0.057	1.60	2
HM66-70180	18	0.092	1.50	2
HM66-70220	22	0.096	1.30	2
HM66-70270	27	0.109	1.20	2
HM66-70330	33	0.124	1.10	2
HM66-70390	39	0.138	1.00	2
HM66-70470	47	0.155	0.95	2
HM66-70560	56	0.202	0.85	2
HM66-70680	68	0.234	0.75	2

## SPECIFICATIONS

Part Number	Inductance Nominal $\mu\text{H} \pm 20\%$	DC Resistance $\Omega$ Max.	Rated Current Amps	Figure
HM66-70820	82	0.324	0.70	2
HM66-70101	100	0.358	0.65	2
HM66-801R5	1.5	0.0081	10.0	3
HM66-802R5	2.5	0.0105	7.50	3
HM66-803R8	3.8	0.013	6.00	3
HM66-805R2	5.2	0.022	5.50	3
HM66-807R0	7.0	0.027	4.80	3
HM66-80100	10	0.035	4.40	3
HM66-80150	15	0.050	3.60	3
HM66-80220	22	0.073	2.90	3
HM66-80330	33	0.093	2.30	3
HM66-80470	47	0.128	2.10	3
HM66-80680	68	0.213	1.50	3
HM66-80101	100	0.304	1.35	3
HM66-80151	150	0.506	1.15	3
HM66-80221	220	0.756	0.92	3
HM66-80331	330	1.090	0.70	3

Comments: Test conditions for case sizes 10, 15, 20, 30, 80 = 100 kHz, 0.1 V without DC current. Test conditions for case sizes 40, 50, 60, 70 = 10 kHz, 0.1 V without DC current. Rated DC current is the approximate current at which inductance will be decreased by 35% from its initial (zero DC) value or the DC current at which  $\Delta T = 40^\circ\text{C}$ , whichever is lower.

## PACKAGING

**Standard:** Embossed Tape & Reel

Reel:	Diameter	=	13" (330.2mm)
	Capacity:		
	Case size 10, 15	=	3,000 Units
	Case size 20, 30, 40	=	2,000 Units
	Case size 50, 60	=	1,500 Units
	Case size 70	=	1,000 Units
	Case size 80	=	800 Units

**OUTLINE DIMENSIONS (Inch/mm)**

**Figure 1**

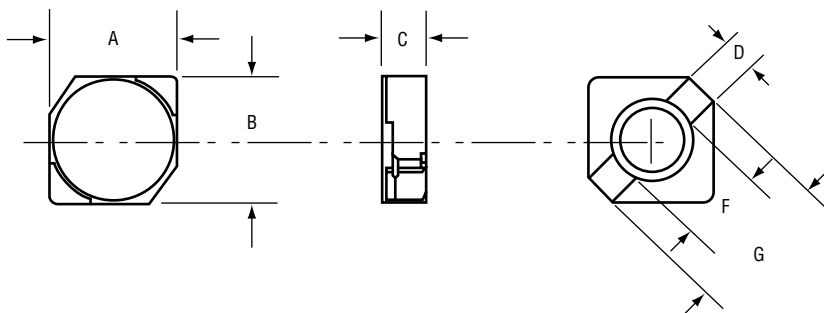

**Figure 2**

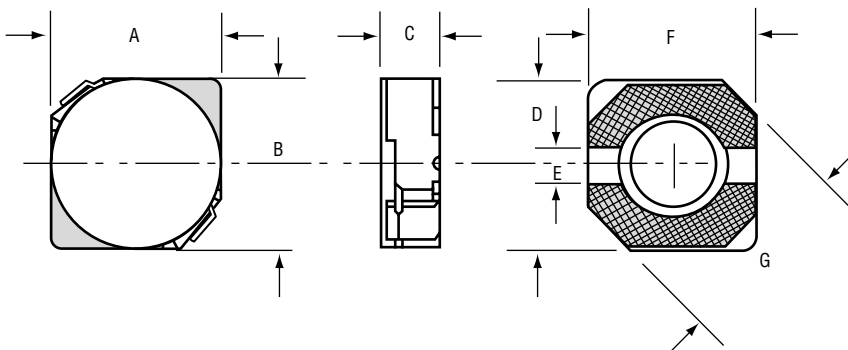

**Figure 3**

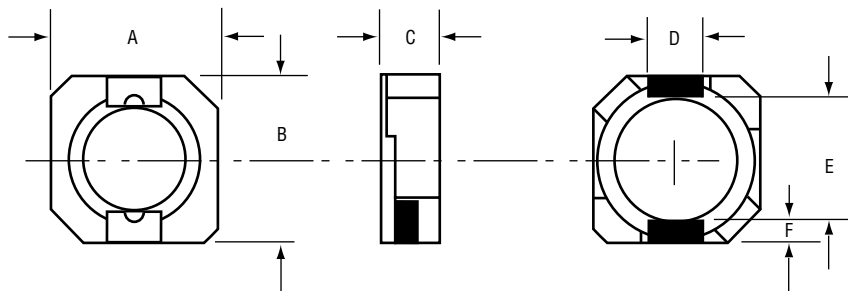

**SOLDER PAD LAYOUTS (Inch/mm)**

Figure 1

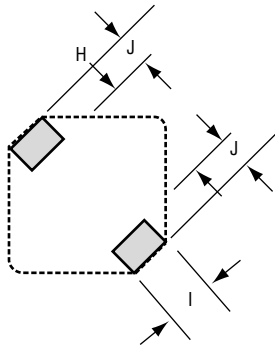

Figure 2

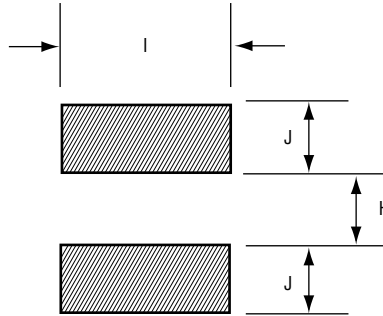
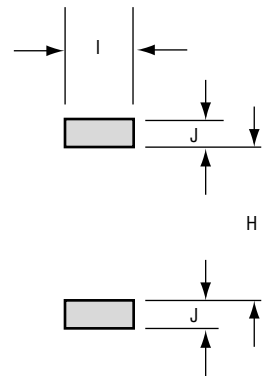

Figure 3



Case Size	Figure	A	B	C Max.	D	E	F	G Max.	H	I	J
10	1	$\frac{.150 \pm .02}{3.8 \pm 0.5}$	$\frac{.150 \pm .02}{3.8 \pm 0.5}$	$\frac{.071}{1.8}$	$\frac{.045 \pm .01}{1.15 \pm 0.25}$	—	$\frac{.110 \pm .004}{2.8 \pm 0.1}$	$\frac{.205}{5.2}$	$\frac{.095}{2.4}$	$\frac{.061}{1.55}$	$\frac{.055}{1.4}$
15	2	$\frac{.150 \pm .012}{3.8 \pm 0.3}$	$\frac{.150 \pm .012}{3.8 \pm 0.3}$	$\frac{.073}{1.85}$	$\frac{.150 \pm .012}{3.8 \pm 0.3}$	$\frac{.043 \pm .006}{1.1 \pm 0.15}$	$\frac{.150 \pm .012}{3.8 \pm 0.3}$	$\frac{.173}{4.4}$	$\frac{.043}{1.1}$	$\frac{.177}{4.5}$	$\frac{.067}{1.7}$
20	2	$\frac{.185 \pm .02}{4.7 \pm 0.5}$	$\frac{.185 \pm .02}{4.7 \pm 0.5}$	$\frac{.083}{2.1}$	$\frac{.177 \pm .012}{4.5 \pm 0.3}$	$\frac{.059 \pm .006}{1.5 \pm 0.15}$	$\frac{.177 \pm .012}{4.5 \pm 0.3}$	$\frac{.272}{6.9}$	$\frac{.059}{1.5}$	$\frac{.209}{5.3}$	$\frac{.075}{1.9}$
30	2	$\frac{.185 \pm .02}{4.7 \pm 0.5}$	$\frac{.185 \pm .02}{4.7 \pm 0.5}$	$\frac{.119}{3.0}$	$\frac{.177 \pm .012}{4.5 \pm 0.3}$	$\frac{.059 \pm .006}{1.5 \pm 0.15}$	$\frac{.177 \pm .012}{4.5 \pm 0.3}$	$\frac{.272}{6.9}$	$\frac{.059}{1.5}$	$\frac{.209}{5.3}$	$\frac{.075}{1.9}$
40	2	$\frac{.225 \pm .02}{5.7 \pm 0.5}$	$\frac{.225 \pm .02}{5.7 \pm 0.5}$	$\frac{.079}{2.0}$	$\frac{.217 \pm .012}{5.5 \pm 0.3}$	$\frac{.079 \pm .006}{2.0 \pm 0.15}$	$\frac{.217 \pm .012}{5.5 \pm 0.3}$	$\frac{.323}{8.2}$	$\frac{.079}{2.0}$	$\frac{.248}{6.3}$	$\frac{.085}{2.15}$
50	2	$\frac{.225 \pm .02}{5.7 \pm 0.5}$	$\frac{.225 \pm .02}{5.7 \pm 0.5}$	$\frac{.119}{3.0}$	$\frac{.217 \pm .012}{5.5 \pm 0.3}$	$\frac{.079 \pm .006}{2.0 \pm 0.15}$	$\frac{.217 \pm .012}{5.5 \pm 0.3}$	$\frac{.323}{8.2}$	$\frac{.079}{2.0}$	$\frac{.248}{6.3}$	$\frac{.085}{2.15}$
60	2	$\frac{.264 \pm .02}{6.7 \pm 0.5}$	$\frac{.264 \pm .02}{6.7 \pm 0.5}$	$\frac{.119}{3.0}$	$\frac{.256 \pm .012}{6.5 \pm 0.3}$	$\frac{.079 \pm .006}{2.0 \pm 0.15}$	$\frac{.256 \pm .012}{6.5 \pm 0.3}$	$\frac{.375}{9.5}$	$\frac{.079}{2.0}$	$\frac{.288}{7.3}$	$\frac{.105}{2.65}$
70	2	$\frac{.264 \pm .02}{6.7 \pm 0.5}$	$\frac{.264 \pm .02}{6.7 \pm 0.5}$	$\frac{.158}{4.0}$	$\frac{.256 \pm .012}{6.5 \pm 0.3}$	$\frac{.079 \pm .006}{2.0 \pm 0.15}$	$\frac{.256 \pm .012}{6.5 \pm 0.3}$	$\frac{.375}{9.5}$	$\frac{.079}{2.0}$	$\frac{.288}{7.3}$	$\frac{.105}{2.65}$
80	3	$\frac{.394 \pm .02}{10.0 \pm 0.5}$	$\frac{.402 \pm .02}{10.2 \pm 0.5}$	$\frac{.158}{4.0}$	$\frac{.118 \pm .004}{3.0 \pm 0.1}$	$\frac{.303 \pm .012}{7.7 \pm 0.3}$	$\frac{.047 \pm .006}{1.2 \pm 0.15}$	—	$\frac{.288}{7.3}$	$\frac{.126}{3.2}$	$\frac{.067}{1.7}$

## ORDERING INFORMATION

