

1-/2-Channel 24-Bit μ Power No Latency $\Delta\Sigma$ ADC in MSOP-10

January 2000

FEATURES

- 24-Bit ADC in Tiny MSOP-10 Package
- 1- or 2-Channel Inputs
- Automatic Channel Selection (Ping-Pong) (LTC2402)
- Zero Scale and Full Scale Set for Reference and Ground Sensing
- **4ppm INL, No Missing Codes**
- **4ppm Full-Scale Error**
- **0.5ppm Offset**
- **0.6ppm Noise**
- Internal Oscillator—No External Components Required
- 110dB Min, 50Hz/60Hz Notch Filter
- **Single Conversion Settling Time for Multiplexed Applications**
- Reference Input Voltage: 0.1V to V_{CC}
- Live Zero—Extended Input Range Accommodates 12.5% Overrange and Underrange
- Single Supply 2.7V to 5.5V Operation
- Low Supply Current (200 μ A) and Auto Shutdown

APPLICATIONS

- Weight Scales
- Direct Temperature Measurement
- Gas Analyzers
- Strain-Gage Transducers
- Instrumentation
- Data Acquisition
- Industrial Process Control

DESCRIPTION

The LTC[®]2401/LTC2402 are 1- and 2-channel 2.7V to 5.5V micropower 24-bit analog-to-digital converters with an integrated oscillator, 4ppm INL and 0.6ppm RMS noise. These ultrasmall devices use delta-sigma technology and a new digital filter architecture that settles in a single cycle. This eliminates the latency found in conventional $\Delta\Sigma$ converters and simplifies multiplexed applications.

Through a single pin, the LTC2401/LTC2402 can be configured for better than 110dB rejection at 50Hz or 60Hz \pm 2%, or can be driven by an external oscillator for a user defined rejection frequency in the range 1Hz to 120Hz. The internal oscillator requires no external frequency setting components.

These converters accept an external reference voltage from 0.1V to V_{CC} . With an extended input conversion range of $-12.5\% V_{REF}$ to $112.5\% V_{REF}$ ($V_{REF} = FS_{SET} - ZS_{SET}$), the LTC2401/LTC2402 smoothly resolve the offset and overrange problems of preceding sensors or signal conditioning circuits.

The LTC2401/LTC2402 communicate through a 2- or 3-wire digital interface that is compatible with SPI and MICROWIRE[™] protocols.

L, LTC and LT are registered trademarks of Linear Technology Corporation. No Latency $\Delta\Sigma$ is a trademark of Linear Technology Corporation. MICROWIRE is a trademark of National Semiconductor Corporation.

TYPICAL APPLICATION

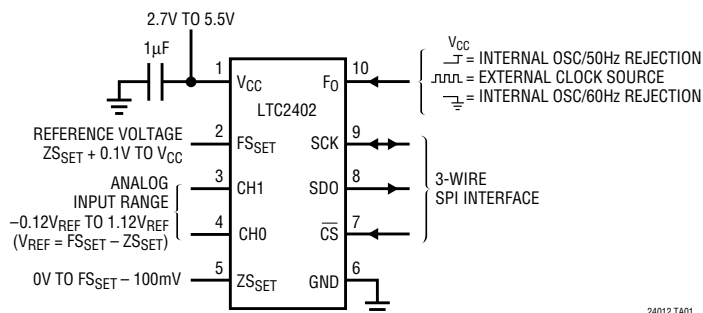

Pseudo Differential Bridge Digitizer

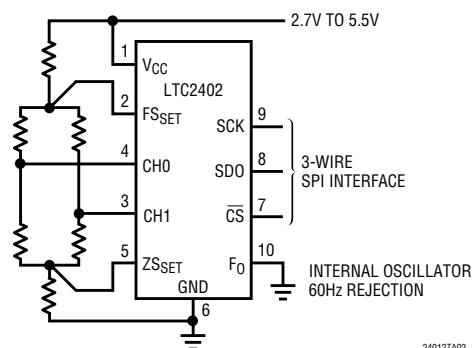

LTC2401/LTC2402

ABSOLUTE MAXIMUM RATINGS (Notes 1, 2)

| | | | |
|--|------------------------------|--|----------------|
| Supply Voltage (V_{CC}) to GND | -0.3V to 7V | Operating Temperature Range | |
| Analog Input Voltage to GND | -0.3V to ($V_{CC} + 0.3V$) | LTC2401/LTC2402C | 0°C to 70°C |
| Reference Input Voltage to GND .. | -0.3V to ($V_{CC} + 0.3V$) | LTC2401/LTC2402I | -40°C to 85°C |
| Digital Input Voltage to GND | -0.3V to ($V_{CC} + 0.3V$) | Storage Temperature Range | -65°C to 150°C |
| Digital Output Voltage to GND | -0.3V to ($V_{CC} + 0.3V$) | Lead Temperature (Soldering, 10 sec) | 300°C |

PACKAGE/ORDER INFORMATION

| | | | |
|--|--------------------------|--|--------------------------|
| | ORDER PART NUMBER | | ORDER PART NUMBER |
| | LTC2401CMS LTC2401IMS | | LTC2402CMS LTC2402IMS |
| | MS10 PART MARKING | | MS10 PART MARKING |
| | LTMB LTMC | | LTMD LTME |

Consult factory for Military grade parts.

CONVERTER CHARACTERISTICS

The ● denotes specifications which apply over the full operating temperature range, otherwise specifications are at $T_A = 25^\circ\text{C}$. $V_{REF} = FS_{SET} - ZS_{SET}$. (Notes 3, 4)

| PARAMETER | CONDITIONS | MIN | TYP | MAX | UNITS |
|--|--|-------|------|-----|---------------------------------|
| Resolution | | ● 24 | | | Bits |
| No Missing Codes Resolution | $0.1V \leq FS_{SET} \leq V_{CC}$, $ZS_{SET} = 0V$ (Note 5) | ● 24 | | | Bits |
| Integral Nonlinearity | $FS_{SET} = 2.5V$, $ZS_{SET} = 0V$ (Note 6) | ● | 2 | 10 | ppm of V_{REF} |
| | $FS_{SET} = 5V$, $ZS_{SET} = 0V$ (Note 6) | ● | 4 | 15 | ppm of V_{REF} |
| Offset Error | $2.5V \leq FS_{SET} \leq V_{CC}$, $ZS_{SET} = 0V$ | ● | 0.5 | 2 | ppm of V_{REF} |
| Offset Error Drift | $2.5V \leq FS_{SET} \leq V_{CC}$, $ZS_{SET} = 0V$ | | 0.01 | | ppm of $V_{REF}/^\circ\text{C}$ |
| Full-Scale Error | $2.5V \leq FS_{SET} \leq V_{CC}$, $ZS_{SET} = 0V$ | ● | 4 | 10 | ppm of V_{REF} |
| Full-Scale Error Drift | $2.5V \leq FS_{SET} \leq V_{CC}$, $ZS_{SET} = 0V$ | | 0.04 | | ppm of $V_{REF}/^\circ\text{C}$ |
| Total Unadjusted Error | $FS_{SET} = 2.5V$, $ZS_{SET} = 0V$ | | 5 | | ppm of V_{REF} |
| | $FS_{SET} = 5V$, $ZS_{SET} = 0V$ | | 10 | | ppm of V_{REF} |
| Output Noise | $V_{IN} = 0V$ (Note 13) | | 3 | | μV_{RMS} |
| Normal Mode Rejection 60Hz $\pm 2\%$ | (Note 7) | ● 110 | 130 | | dB |
| Normal Mode Rejection 50Hz $\pm 2\%$ | (Note 8) | ● 110 | 130 | | dB |
| Power Supply Rejection, DC | $FS_{SET} = 2.5V$, $ZS_{SET} = 0V$, $V_{IN} = 0V$ | | 100 | | dB |
| Power Supply Rejection, 60Hz $\pm 2\%$ | $FS_{SET} = 2.5V$, $ZS_{SET} = 0V$, $V_{IN} = 0V$, (Note 7) | | 110 | | dB |
| Power Supply Rejection, 50Hz $\pm 2\%$ | $FS_{SET} = 2.5V$, $ZS_{SET} = 0V$, $V_{IN} = 0V$, (Note 8) | | 110 | | dB |

ANALOG INPUT AND REFERENCE

The ● denotes specifications which apply over the full operating temperature range, otherwise specifications are at $T_A = 25^\circ\text{C}$. $V_{\text{REF}} = \text{FS}_{\text{SET}} - \text{ZS}_{\text{SET}}$. (Note 3)

| SYMBOL | PARAMETER | CONDITIONS | MIN | TYP | MAX | UNITS |
|--------------------------|--------------------------------|---|----------------------------------|-----|--------------------------------|-------|
| V_{IN} | Input Voltage Range | (Note 14) | ● $-0.125 \cdot V_{\text{REF}}$ | | $1.125 \cdot V_{\text{REF}}$ | V |
| FS_{SET} | Full-Scale Set Range | | ● $0.1 + \text{ZS}_{\text{SET}}$ | | V_{CC} | V |
| ZS_{SET} | Zero-Scale Set Range | | ● 0 | | $\text{FS}_{\text{SET}} - 0.1$ | V |
| $C_{\text{S(IN)}}$ | Input Sampling Capacitance | | | 10 | | pF |
| $C_{\text{S(REF)}}$ | Reference Sampling Capacitance | | | 15 | | pF |
| $I_{\text{IN(LEAK)}}$ | Input Leakage Current | $\overline{\text{CS}} = V_{\text{CC}}$ | ● -10 | 1 | 10 | nA |
| $I_{\text{REF(LEAK)}}$ | Reference Leakage Current | $V_{\text{REF}} = 2.5\text{V}$, $\overline{\text{CS}} = V_{\text{CC}}$ | ● -12 | 1 | 12 | nA |

DIGITAL INPUTS AND DIGITAL OUTPUTS

The ● denotes specifications which apply over the full operating temperature range, otherwise specifications are at $T_A = 25^\circ\text{C}$. (Note 3)

| SYMBOL | PARAMETER | CONDITIONS | MIN | TYP | MAX | UNITS |
|-----------------|---------------------------|--|-------------------------|-----|-----|---------------|
| V_{IH} | High Level Input Voltage | $2.7\text{V} \leq V_{\text{CC}} \leq 5.5\text{V}$ | ● 2.5 | | | V |
| | CS , F_0 | $2.7\text{V} \leq V_{\text{CC}} \leq 3.3\text{V}$ | 2.0 | | | V |
| V_{IL} | Low Level Input Voltage | $4.5\text{V} \leq V_{\text{CC}} \leq 5.5\text{V}$ | ● | | 0.8 | V |
| | CS , F_0 | $2.7\text{V} \leq V_{\text{CC}} \leq 5.5\text{V}$ | | | 0.6 | V |
| V_{IH} | High Level Input Voltage | $2.7\text{V} \leq V_{\text{CC}} \leq 5.5\text{V}$ (Note 9) | ● 2.5 | | | V |
| | SCK | $2.7\text{V} \leq V_{\text{CC}} \leq 3.3\text{V}$ (Note 9) | 2.0 | | | V |
| V_{IL} | Low Level Input Voltage | $4.5\text{V} \leq V_{\text{CC}} \leq 5.5\text{V}$ (Note 9) | ● | | 0.8 | V |
| | SCK | $2.7\text{V} \leq V_{\text{CC}} \leq 5.5\text{V}$ (Note 9) | | | 0.6 | V |
| I_{IN} | Digital Input Current | $0\text{V} \leq V_{\text{IN}} \leq V_{\text{CC}}$ | ● -10 | | 10 | μA |
| | CS , F_0 | | | | | |
| I_{IN} | Digital Input Current | $0\text{V} \leq V_{\text{IN}} \leq V_{\text{CC}}$ (Note 9) | ● -10 | | 10 | μA |
| | SCK | | | | | |
| C_{IN} | Digital Input Capacitance | | | 10 | | pF |
| | CS , F_0 | | | | | |
| C_{IN} | Digital Input Capacitance | (Note 9) | | 10 | | pF |
| | SCK | | | | | |
| V_{OH} | High Level Output Voltage | $I_0 = -800\mu\text{A}$ | ● $V_{\text{CC}} - 0.5$ | | | V |
| | SDO | | | | | |
| V_{OL} | Low Level Output Voltage | $I_0 = 1.6\text{mA}$ | ● | | 0.4 | V |
| | SDO | | | | | |
| V_{OH} | High Level Output Voltage | $I_0 = -800\mu\text{A}$ (Note 10) | ● $V_{\text{CC}} - 0.5$ | | | V |
| | SCK | | | | | |
| V_{OL} | Low Level Output Voltage | $I_0 = 1.6\text{mA}$ (Note 10) | ● | | 0.4 | V |
| | SCK | | | | | |
| I_{OZ} | High-Z Output Leakage | | ● -10 | | 10 | μA |
| | SDO | | | | | |

POWER REQUIREMENTS

The ● denotes specifications which apply over the full operating temperature range, otherwise specifications are at $T_A = 25^\circ\text{C}$. (Note 3)

| SYMBOL | PARAMETER | CONDITIONS | MIN | TYP | MAX | UNITS |
|-----------------|-----------------|--|-------|-----|-----|---------------|
| V_{CC} | Supply Voltage | | ● 2.7 | | 5.5 | V |
| I_{CC} | Supply Current | | | | | |
| | Conversion Mode | $\overline{\text{CS}} = 0\text{V}$ (Note 12) | ● | 200 | 300 | μA |
| | Sleep Mode | $\overline{\text{CS}} = V_{\text{CC}}$ (Note 12) | ● | 20 | 30 | μA |

TIMING CHARACTERISTICS

The ● denotes specifications which apply over the full operating temperature range, otherwise specifications are at $T_A = 25^\circ\text{C}$. (Note 3)

| SYMBOL | PARAMETER | CONDITIONS | MIN | TYP | MAX | UNITS |
|-------------------------|---|---|-------------|---|-------------------------|-----------------|
| f_{EOSC} | External Oscillator Frequency Range | ● | 2.56 | | 307.2 | kHz |
| t_{HEO} | External Oscillator High Period | ● | 0.5 | | 390 | μs |
| t_{LEO} | External Oscillator Low Period | ● | 0.5 | | 390 | μs |
| t_{CONV} | Conversion Time | $F_0 = 0\text{V}$ $F_0 = V_{\text{CC}}$ External Oscillator (Note 11) | ● ● ● | 130.66 156.80 20480/ f_{EOSC} (in kHz) | 133.33 160 163.20 | 136 ms ms |
| f_{ISCK} | Internal SCK Frequency | Internal Oscillator (Note 10) External Oscillator (Notes 10, 11) | | 19.2 $f_{\text{EOSC}}/8$ | | kHz kHz |
| D_{ISCK} | Internal SCK Duty Cycle | (Note 10) | 45 | | 55 | % |
| f_{ESCK} | External SCK Frequency Range | (Note 9) | ● | | 2000 | kHz |
| t_{LESCK} | External SCK Low Period | (Note 9) | ● | 250 | | ns |
| t_{HESCK} | External SCK High Period | (Note 9) | ● | 250 | | ns |
| $t_{\text{DOUT_ISCK}}$ | Internal SCK 32-Bit Data Output Time | Internal Oscillator (Notes 10, 12) External Oscillator (Notes 10, 11) | ● ● | 1.64 256/ f_{EOSC} (in kHz) | 1.67 1.70 | ms ms |
| $t_{\text{DOUT_ESCK}}$ | External SCK 32-Bit Data Output Time | (Note 9) | ● | 32/ f_{ESCK} (in kHz) | | ms |
| t_1 | $\overline{\text{CS}} \downarrow$ to SDO Low Z | | ● | 0 | 150 | ns |
| t_2 | $\overline{\text{CS}} \uparrow$ to SDO High Z | | ● | 0 | 150 | ns |
| t_3 | $\overline{\text{CS}} \downarrow$ to SCK \downarrow | (Note 10) | ● | 0 | 150 | ns |
| t_4 | $\overline{\text{CS}} \downarrow$ to SCK \uparrow | (Note 9) | ● | 50 | | ns |
| t_{KQMAX} | SCK \downarrow to SDO Valid | | ● | | 200 | ns |
| t_{KQMIN} | SDO Hold After SCK \downarrow | (Note 5) | ● | 15 | | ns |
| t_5 | SCK Set-Up Before $\overline{\text{CS}} \downarrow$ | | ● | 50 | | ns |
| t_6 | SCK Hold After $\overline{\text{CS}} \downarrow$ | | ● | | 50 | ns |

Note 1: Absolute Maximum Ratings are those values beyond which the life of the device may be impaired.

Note 2: All voltage values are with respect to GND.

Note 3: $V_{\text{CC}} = 2.7$ to 5.5V unless otherwise specified. Input source resistance = 0Ω .

Note 4: Internal Conversion Clock source with the F_0 pin tied to GND or to V_{CC} or to external conversion clock source with $f_{\text{EOSC}} = 153600\text{Hz}$ unless otherwise specified.

Note 5: Guaranteed by design, not subject to test.

Note 6: Integral nonlinearity is defined as the deviation of a code from a straight line passing through the actual endpoints of the transfer curve. The deviation is measured from the center of the quantization band.

Note 7: $F_0 = 0\text{V}$ (internal oscillator) or $f_{\text{EOSC}} = 153600\text{Hz} \pm 2\%$ (external oscillator).

Note 8: $F_0 = V_{\text{CC}}$ (internal oscillator) or $f_{\text{EOSC}} = 128000\text{Hz} \pm 2\%$ (external oscillator).

Note 9: The converter is in external SCK mode of operation such that the SCK pin is used as digital input. The frequency of the clock signal driving SCK during the data output is f_{ESCK} and is expressed in kHz.

Note 10: The converter is in internal SCK mode of operation such that the SCK pin is used as digital output. In this mode of operation, the SCK pin has a total equivalent load capacitance $C_{\text{LOAD}} = 20\text{pF}$.

Note 11: The external oscillator is connected to the F_0 pin. The external oscillator frequency, f_{EOSC} , is expressed in kHz.

Note 12: The converter uses the internal oscillator.

$F_0 = 0\text{V}$ or $F_0 = V_{\text{CC}}$.

Note 13: The output noise includes the contribution of the internal calibration operations.

Note 14: For reference voltage values $V_{\text{REF}} > 2.5\text{V}$, the extended input of $-0.125 \cdot V_{\text{REF}}$ to $1.125 \cdot V_{\text{REF}}$ is limited by the absolute maximum rating of the Analog Input Voltage pin (Pin 3). For $2.5\text{V} < V_{\text{REF}} \leq 0.267\text{V} + 0.89 \cdot V_{\text{CC}}$, the input voltage range is -0.3V to $1.125 \cdot V_{\text{REF}}$. For $0.267\text{V} + 0.89 \cdot V_{\text{CC}} < V_{\text{REF}} \leq V_{\text{CC}}$, the input voltage range is -0.3V to $V_{\text{CC}} + 0.3\text{V}$.

PIN FUNCTIONS

V_{CC} (Pin 1): Positive Supply Voltage. Bypass to GND (Pin 4) with a 10 μ F tantalum capacitor in parallel with 0.1 μ F ceramic capacitor as close to the part as possible.

FS_{SET} (Pin 2): Full-Scale Set Input. This pin defines the full-scale input value. When $V_{IN} = FS_{SET}$, the ADC outputs full scale (FFFF_H). The total reference voltage is $FS_{SET} - ZS_{SET}$.

CH0, CH1 (Pins 4, 3): Analog Input Channels. The input voltage range is $-0.125 \cdot V_{REF}$ to $1.125 \cdot V_{REF}$. For $V_{REF} > 2.5V$, the input voltage range may be limited by the absolute maximum rating of $-0.3V$ to $V_{CC} + 0.3V$. Conversions are performed alternately between CH0 and CH1 for the LTC2402. Pin 4 is a No Connect (NC) on the LTC2401.

ZS_{SET} (Pin 5): Zero-Scale Set Input. This pin defines the zero-scale input value. When $V_{IN} = ZS_{SET}$, the ADC outputs zero scale (00000_H).

GND (Pin 6): Ground. Shared pin for analog ground, digital ground, reference ground and signal ground. Should be connected directly to a ground plane through a minimum length trace or it should be the single-point-ground in a single-point grounding system.

\overline{CS} (Pin 7): Active LOW Digital Input. A LOW on this pin enables the SDO digital output and wakes up the ADC. Following each conversion, the ADC automatically enters the Sleep mode and remains in this low power state as long as \overline{CS} is HIGH. A LOW on \overline{CS} wakes up the ADC. A LOW-to-HIGH transition on this pin disables the SDO digital output. A LOW-to-HIGH transition on \overline{CS} during the Data Output transfer aborts the data transfer and starts a new conversion.

SDO (Pin 8): Three-State Digital Output. During the data output period, this pin is used for serial data output. When the chip select \overline{CS} is HIGH ($\overline{CS} = V_{CC}$), the SDO pin is in a high impedance state. During the Conversion and Sleep periods, this pin can be used as a conversion status output. The conversion status can be observed by pulling \overline{CS} LOW.

SCK (Pin 9): Bidirectional Digital Clock Pin. In the Internal Serial Clock Operation mode, SCK is used as digital output for the internal serial interface clock during the data output period. In the External Serial Clock Operation mode, SCK is used as digital input for the external serial interface. An internal pull-up current source is automatically activated in Internal Serial Clock Operation mode. The Serial Clock mode is determined by the level applied to SCK at power up and the falling edge of \overline{CS} .

F₀ (Pin 10): Frequency Control Pin. Digital input that controls the ADC's notch frequencies and conversion time. When the F₀ pin is connected to V_{CC} ($F_0 = V_{CC}$), the converter uses its internal oscillator and the digital filter's first null is located at 50Hz. When the F₀ pin is connected to GND ($F_0 = 0V$), the converter uses its internal oscillator and the digital filter's first null is located at 60Hz. When F₀ is driven by an external clock signal with a frequency f_{EOSC} , the converter uses this signal as its clock and the digital filter first null is located at a frequency $f_{EOSC}/2560$.

APPLICATIONS INFORMATION

Output Data Format

The LTC2401/LTC2402 serial output data stream is 32 bits long. The first 4 bits represent status information indicating the sign, selected channel, input range and conversion state. The next 24 bits are the conversion result, MSB first. The remaining 4 bits are sub LSBs beyond the 24-bit level that may be included in averaging or discarded without loss of resolution.

Bit 31 (first output bit) is the end of conversion (\overline{EOC}) indicator. This bit is available at the SDO pin during the conversion and sleep states whenever the \overline{CS} pin is LOW. This bit is HIGH during the conversion and goes LOW when the conversion is complete.

Bit 30 (second output bit) is LOW if the last conversion was performed on CH0 and HIGH for CH1.

Bit 29 (third output bit) is the conversion result sign indicator (SIG). If V_{IN} is >0 , this bit is HIGH. If V_{IN} is <0 , this bit is LOW. The sign bit changes state during the zero code.

Bit 28 (forth output bit) is the extended input range (EXR) indicator. If the input is within the normal input range $0 \leq V_{IN} \leq V_{REF}$, this bit is LOW. If the input is outside the normal input range, $V_{IN} > V_{REF}$ or $V_{IN} < 0$, this bit is HIGH.

The function of these bits is summarized in Table 1.

Table 1. LTC2401/LTC2402 Status Bits

| Input Range | Bit 31 \overline{EOC} | Bit 30 CH0/CH1 | Bit 29 SIG | Bit 28 EXR |
|---------------------------|----------------------------|-------------------|---------------|---------------|
| $V_{IN} > V_{REF}$ | 0 | 0/1 | 1 | 1 |
| $0 < V_{IN} \leq V_{REF}$ | 0 | 0/1 | 1 | 0 |
| $V_{IN} = 0^+/0^-$ | 0 | 0/1 | 1/0 | 0 |
| $V_{IN} < 0$ | 0 | 0/1 | 0 | 1 |

Bit 27 (fifth output bit) is the most significant bit (MSB).

Bits 27-4 are the 24-bit conversion result MSB first.

Bit 4 is the least significant bit (LSB).

Bits 3-0 are sub LSBs below the 24-bit level. Bits 3-0 may be included in averaging or discarded without loss of resolution.

Data is shifted out of the SDO pin under control of the serial clock (SCK), see Figure 1. Whenever \overline{CS} is HIGH, SDO remains high impedance and any SCK clock pulses are ignored by the internal data out shift register.

In order to shift the conversion result out of the device, \overline{CS} must first be driven LOW. \overline{EOC} is seen at the SDO pin of the device once \overline{CS} is pulled LOW. \overline{EOC} changes real time from HIGH to LOW at the completion of a conversion. This signal may be used as an interrupt for an external microcontroller. Bit 31 (\overline{EOC}) can be captured on the first rising edge of SCK. Bit 30 is shifted out of the device on the first

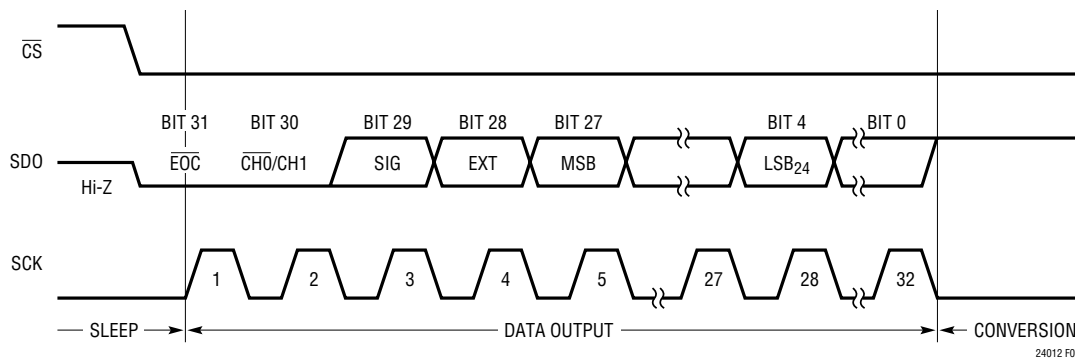

Figure 1. Output Data Timing

APPLICATIONS INFORMATION

falling edge of SCK. The final data bit (Bit 0) is shifted out on the falling edge of the 31st SCK and may be latched on the rising edge of the 32nd SCK pulse. On the falling edge of the 32nd SCK pulse, SDO goes HIGH indicating a new conversion cycle has been initiated. This bit serves as $\overline{\text{EOC}}$ (Bit 31) for the next conversion cycle. Table 2 summarizes the output data format.

As long as the voltage on the V_{IN} pin is maintained within the -0.3V to $(V_{\text{CC}} + 0.3\text{V})$ absolute maximum operating range, a conversion result is generated for any input value from $-0.125 \cdot V_{\text{REF}}$ to $1.125 \cdot V_{\text{REF}}$. For input voltages greater than $1.125 \cdot V_{\text{REF}}$, the conversion result is clamped to the value corresponding to $1.125 \cdot V_{\text{REF}}$. For input voltages below $-0.125 \cdot V_{\text{REF}}$, the conversion result is clamped to the value corresponding to $-0.125 \cdot V_{\text{REF}}$.

Single Ended Half-Bridge Digitizer with Reference and Ground Sensing

Sensors convert real world phenomena (temperature, pressure, gas levels, etc.) into a voltage. Typically, this voltage is generated by passing an excitation current

through the sensor. The wires connecting the sensor to the ADC form parasitic resistors R_{P1} and R_{P2} . The excitation current also flows through parasitic resistors R_{P1} and R_{P2} , as shown in Figure 2. The voltage drop across these parasitic resistors leads to systematic offset and full-scale errors.

In order to eliminate the errors associated with these parasitic resistors, the LTC2401/LTC2402 include a full-scale set input (FS_{SET}) and a zero-scale set input (ZS_{SET}). As shown in Figure 3, the FS_{SET} pin acts as a zero input full-scale sense input. Errors due to parasitic resistance R_{P1} in series with the half-bridge sensor are

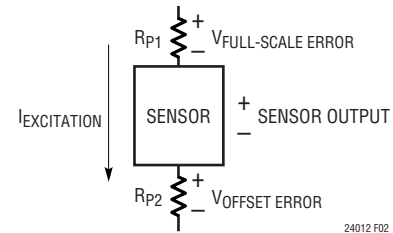

Figure 2. Errors Due to Excitation Currents

Table 2. LTC2401/LTC2402 Output Data Format

| Input Voltage | Bit 31 $\overline{\text{EOC}}$ | Bit 30 $\overline{\text{CH}}/\text{CH1}$ | Bit 29 SIG | Bit 28 EXR | Bit 27 MSB | Bit 26 | Bit 25 | Bit 24 | Bit 23 | ... | Bit 4 LSB | Bit 3-0 SUB LSBs^* |
|---|-----------------------------------|---|------------------------|------------------------|------------------------|--------|--------|--------|--------|-----|-----------------------|--------------------------------|
| $V_{\text{IN}} > 9/8 \cdot V_{\text{REF}}$ | 0 | $\overline{\text{CH}}/\text{CH1}$ | 1 | 1 | 0 | 0 | 0 | 1 | 1 | ... | 1 | X |
| $9/8 \cdot V_{\text{REF}}$ | 0 | $\overline{\text{CH}}/\text{CH1}$ | 1 | 1 | 0 | 0 | 0 | 1 | 1 | ... | 1 | X |
| $V_{\text{REF}} + 1\text{LSB}$ | 0 | $\overline{\text{CH}}/\text{CH1}$ | 1 | 1 | 0 | 0 | 0 | 0 | 0 | ... | 0 | X |
| V_{REF} | 0 | $\overline{\text{CH}}/\text{CH1}$ | 1 | 0 | 1 | 1 | 1 | 1 | 1 | ... | 1 | X |
| $3/4V_{\text{REF}} + 1\text{LSB}$ | 0 | $\overline{\text{CH}}/\text{CH1}$ | 1 | 0 | 1 | 1 | 0 | 0 | 0 | ... | 0 | X |
| $3/4V_{\text{REF}}$ | 0 | $\overline{\text{CH}}/\text{CH1}$ | 1 | 0 | 1 | 0 | 1 | 1 | 1 | ... | 1 | X |
| $1/2V_{\text{REF}} + 1\text{LSB}$ | 0 | $\overline{\text{CH}}/\text{CH1}$ | 1 | 0 | 1 | 0 | 0 | 0 | 0 | ... | 0 | X |
| $1/2V_{\text{REF}}$ | 0 | $\overline{\text{CH}}/\text{CH1}$ | 1 | 0 | 0 | 1 | 1 | 1 | 1 | ... | 1 | X |
| $1/4V_{\text{REF}} + 1\text{LSB}$ | 0 | $\overline{\text{CH}}/\text{CH1}$ | 1 | 0 | 0 | 1 | 0 | 0 | 0 | ... | 0 | X |
| $1/4V_{\text{REF}}$ | 0 | $\overline{\text{CH}}/\text{CH1}$ | 1 | 0 | 0 | 0 | 1 | 1 | 1 | ... | 1 | X |
| $0^+/0^-$ | 0 | $\overline{\text{CH}}/\text{CH1}$ | $1/0^{**}$ | 0 | 0 | 0 | 0 | 0 | 0 | ... | 0 | X |
| -1LSB | 0 | $\overline{\text{CH}}/\text{CH1}$ | 0 | 1 | 1 | 1 | 1 | 1 | 1 | ... | 1 | X |
| $-1/8 \cdot V_{\text{REF}}$ | 0 | $\overline{\text{CH}}/\text{CH1}$ | 0 | 1 | 1 | 1 | 1 | 0 | 0 | ... | 0 | X |
| $V_{\text{IN}} < -1/8 \cdot V_{\text{REF}}$ | 0 | $\overline{\text{CH}}/\text{CH1}$ | 0 | 1 | 1 | 1 | 1 | 0 | 0 | ... | 0 | X |

*The sub LSBs are valid conversion results beyond the 24-bit level that may be included in averaging or discarded without loss of resolution.

**The sign bit changes state during the 0 code.

APPLICATIONS INFORMATION

removed by the FS_{SET} input to the ADC. The absolute full-scale output of the ADC (data out = $FFFFFF_{HEX}$) will occur at $V_{IN} = V_B = FS_{SET}$, see Figure 4. Similarly, the offset errors due to R_{P2} are removed by the ground sense input ZS_{SET} . The absolute zero output of the ADC (data out = 000000_{HEX}) occurs at $V_{IN} = V_A = ZS_{SET}$. Parasitic resistors R_{P3} to R_{P5} have negligible errors due to the 1nA (typ) leakage current at pins FS_{SET} , ZS_{SET} and V_{IN} . The wide dynamic input range (-300mV to 5.3V) and low noise (0.6ppm RMS) enable the LTC2401 or the LTC2402 to directly digitize the output of the bridge sensor.

The LTC2402 is ideal for applications requiring continuous monitoring of two input sensors. As shown in Figure 5, the LTC2402 can monitor both a thermocouple temperature probe and a cold junction temperature sensor. Absolute temperature measurements can be performed with a variety of thermocouples using digital cold junction compensation.

The selection between CH0 and CH1 is automatic. Initially, after power-up, a conversion is performed on CH0. For each subsequent conversion, the input channel selection

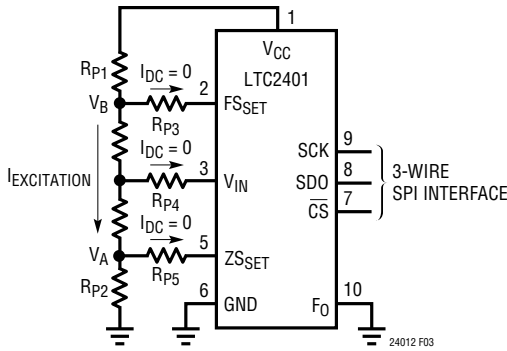

Figure 3. Half-Bridge Digitizer with Zero-Scale and Full-Scale Sense

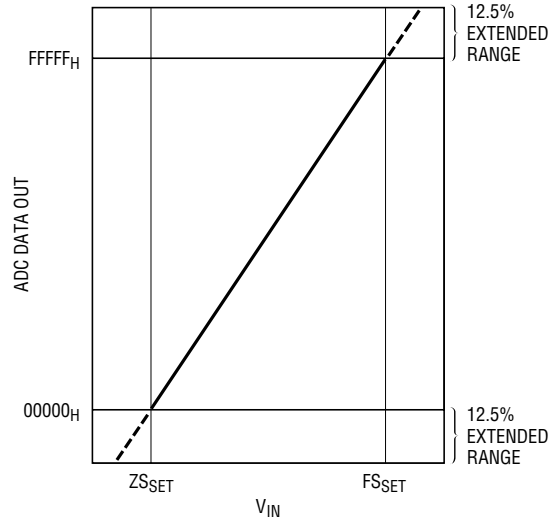

Figure 4. Transfer Curve with Zero-Scale and Full-Scale Set

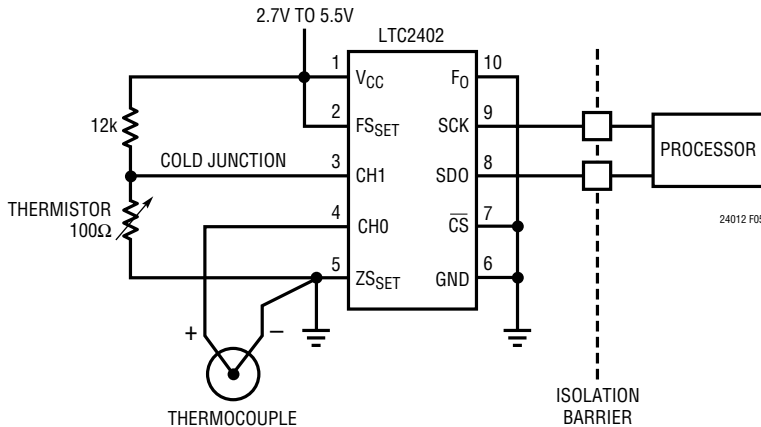

Figure 5. Isolated Temperature Measurement

APPLICATIONS INFORMATION

is alternated. Embedded within the serial data output is a status bit indicating which channel corresponds to the conversion result. If the conversion was performed on CH0, this bit (Bit 30) is LOW and is HIGH if the conversion was performed on CH1 (see Figure 6).

There are no extra control or status pins required to perform the alternating 2-channel measurements. The LTC2402 only requires two digital signals (SCK and SDO). This simplification is ideal for isolated temperature measurements or systems where minimal control signals are available.

Pseudo Differential Applications

Generally, designers choose fully differential topologies for several reasons. First, the interface to a 4- or 6-wire bridge is simple (it is a differential output). Second, they require good rejection of line frequency noise. Third, they

typically look at a small differential signal sitting on a large common mode voltage; they need accurate measurements of the differential signal independent of the common mode input voltage. Many applications currently using fully differential analog-to-digital converters for any of the above reasons may migrate to a pseudo differential conversion using the LTC2402.

Direct Connection to a Full Bridge

The LTC2402 interfaces directly to a 4- or 6-wire bridge, as shown in Figure 7. Like the LTC2401, the LTC2402 includes a FS_{SET} and a ZS_{SET} for sensing the excitation voltage directly across the bridge. This eliminates errors due to excitation currents flowing through parasitic resistors. The LTC2402 also includes two single ended input channels which can tie directly to the differential output of the bridge. The two conversion results may be digitally subtracted yielding the differential result.

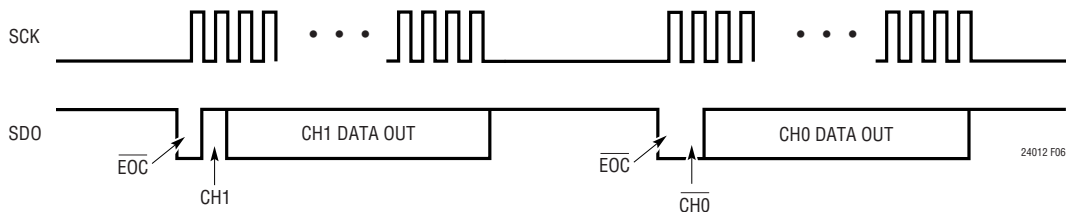

Figure 6. Embedded Selected Channel Indicator

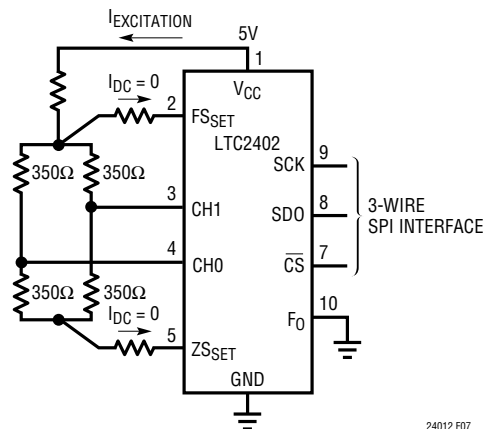

Figure 7. Pseudo Differential Strain Gauge Application

APPLICATIONS INFORMATION

The LTC2402's single ended rejection of line frequencies ($\pm 2\%$) and harmonics is better than 110dB. Since the device performs two independent single ended conversions each with $>110\text{dB}$ rejection, the overall common mode and differential rejection is much better than the 80dB rejection typically found in other differential input delta-sigma converters.

In addition to excellent rejection of line frequency noise, the LTC2402 also exhibits excellent single ended noise rejection over a wide range of frequencies due to its 4th order sinc filter. Each single ended conversion independently rejects high frequency noise ($>60\text{Hz}$). Care must be taken to insure noise at frequencies below 15Hz and at multiples of the ADC sample rate (15,600Hz) are not present. For this application, it is recommended the LTC2402 is placed in close proximity to the bridge sensor in order to reduce the noise injected into the ADC input. By performing three successive conversions (CH0-CH1-CH0), the drift and low frequency noise can be measured and compensated for digitally.

The absolute accuracy (less than 10 ppm total error) of the LTC2402 enables extremely accurate measurement of small signals sitting on large voltages. Each of the two pseudo differential measurements performed by the LTC2402 is absolutely accurate independent of the common mode voltage output from the bridge. The pseudo differential result obtained from digitally subtracting the two single ended conversion results is accurate to within

the noise level of the device ($3\mu\text{V}_{\text{RMS}}$) divided by square root of 2, independent of the common mode input voltage.

Typically, a bridge sensor outputs 2mV/V full scale. With a 5V excitation, this translates to a full-scale output of 10mV. Divided by the RMS noise of $4.2\mu\text{V}$ ($= 3\mu\text{V} \cdot 1.414$), this circuit yields 2,300 counts with no averaging or amplification. If more counts are required, several conversions may be averaged (the number of effective counts is increased by a factor of square root of 2 for each doubling of averages).

An RTD Temperature Digitizer

RTDs used in remote temperature measurements often have long lead lengths between the ADC and RTD sensor. These long lead lengths lead to voltage drops due to excitation current in the interconnect to the RTD. This voltage drop can be measured and digitally removed using the LTC2402 (see Figure 8).

The excitation current (typically 200 μA) flows from the ADC through a long lead length to the remote temperature sensor (RTD). This current is applied to the RTD, whose resistance changes as a function of temperature (100Ω to 400Ω for 0°C to 800°C). The same excitation current flows back to the ADC ground and generates another voltage drop across the return leads. In order to get an accurate measurement of the temperature, these voltage drops must be measured and removed from the conversion result. Assuming the resistance is approximately the same

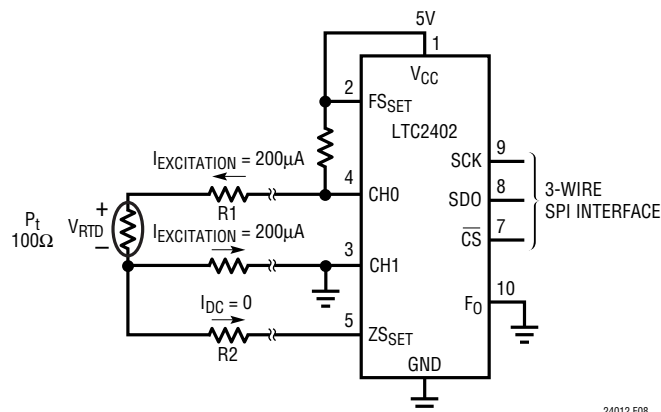
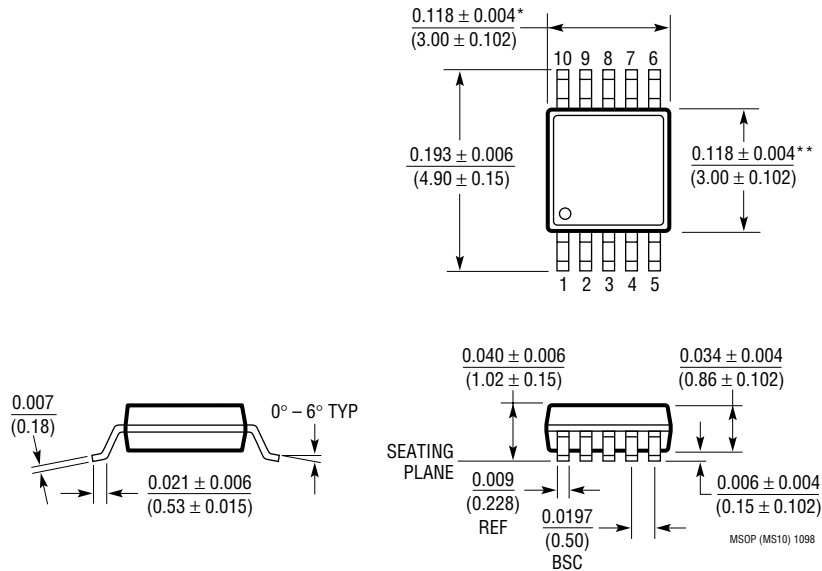

Figure 8. RTD Remote Temperature Measurement

PACKAGE INFORMATION Dimensions in inches (millimeters) unless otherwise noted.

MS10 Package
10-Lead Plastic MSOP
 (LTC DWG # 05-08-1661)



* DIMENSION DOES NOT INCLUDE MOLD FLASH, PROTRUSIONS OR GATE BURRS. MOLD FLASH, PROTRUSIONS OR GATE BURRS SHALL NOT EXCEED 0.006" (0.152mm) PER SIDE
 ** DIMENSION DOES NOT INCLUDE INTERLEAD FLASH OR PROTRUSIONS. INTERLEAD FLASH OR PROTRUSIONS SHALL NOT EXCEED 0.006" (0.152mm) PER SIDE

RELATED PARTS

| PART NUMBER | DESCRIPTION | COMMENTS |
|-----------------|--|--|
| LT1019 | Precision Bandgap Reference, 2.5V, 5V | 3ppm/°C Drift, 0.05% Max |
| LT1025 | Micropower Thermocouple Cold Junction Compensator | 80µA Supply Current, 0.5°C Initial Accuracy |
| LTC1043 | Dual Precision Instrumentation Switched Capacitor Building Block | Precise Charge, Balanced Switching, Low Power |
| LTC1050 | Precision Chopper Stabilized Op Amp | No External Components 5µV Offset, 1.6µV _{p-p} Noise |
| LT1236A-5 | Precision Bandgap Reference, 5V | 0.05% Max, 5ppm/°C Drift |
| LTC1391 | 8-Channel Multiplexer | Low R _{ON} : 45Ω, Low Charge Injection Serial Interface |
| LT1460 | Micropower Series Reference | 0.075% Max, 10ppm/°C Max Drift, 2.5V, 5V and 10V Versions, MSOP, PDIP, SO-8, SOT-23 and TO-92 Packages |
| LT1461-2.5 | Precision Micropower Voltage Reference | 50µA Supply Current, 3ppm/°C Drift |
| LTC2400 | 24-Bit, No Latency ΔΣ ADC in SO-8 | 4ppm INL, 10ppm Total Unadjusted Error, 200µA |
| LTC2404/LTC2408 | 4-/8-Channel, 24-Bit, No Latency ΔΣ ADC | 4ppm INL, 10ppm Total Unadjusted Error, 200µA |