

MITSUBISHI RF POWER MODULE
M68742

SILICON MOS FET POWER AMPLIFIER, 903-905MHz, 1.8W, FM PORTABLE RADIO

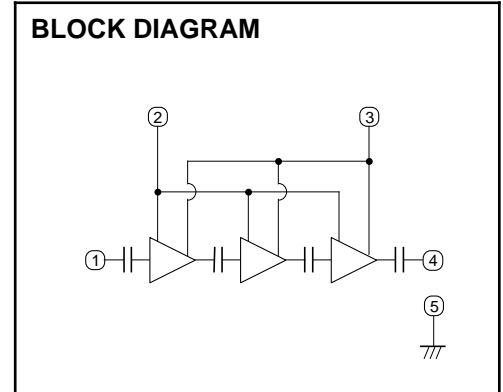
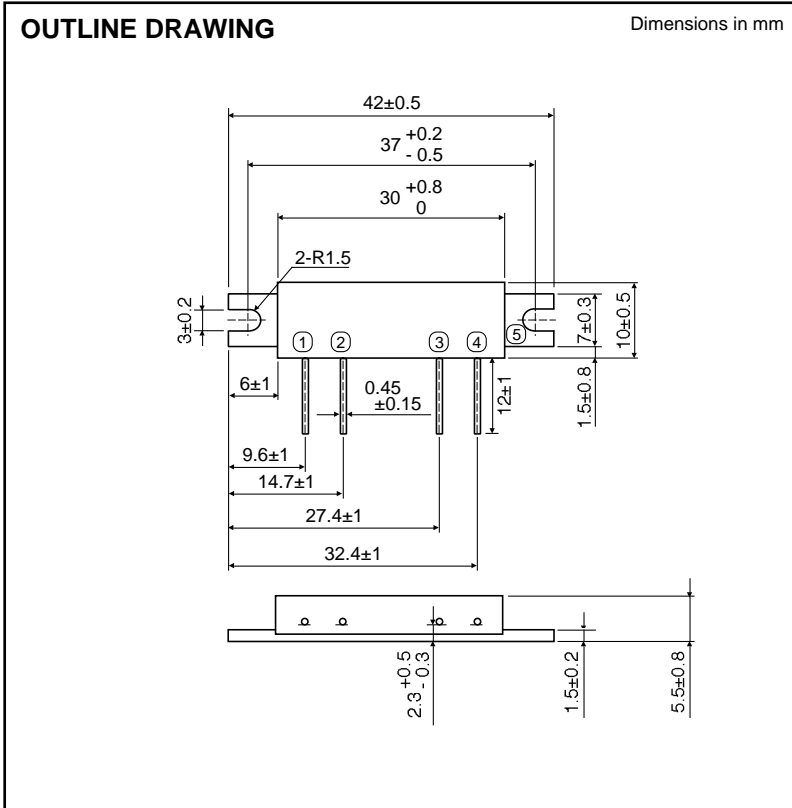

- PIN:
 ① Pin : RF INPUT
 ② V_{GG} : GATE BIAS SUPPLY
 ③ V_{DD} : DRAIN BIAS SUPPLY
 ④ P_O : RF OUTPUT
 ⑤ GND: FIN

ABSOLUTE MAXIMUM RATINGS (T_C=25°C unless otherwise noted)

Symbol	Parameter	Conditions	Ratings	Unit
V _{DD}	Supply voltage	Z _G =Z _L =50	13	V
V _{GG}	Gate bias voltage		5.5	V
P _{in}	Input power	f=903-905MHz, Z _G =Z _L =50	10	mW
P _O	Output power	f=903-905MHz, Z _G =Z _L =50	5	W
T _{C(OP)}	Operation case temperature	f=903-905MHz, Z _G =Z _L =50	-30 to +100	°C
T _{stg}	Storage temperature		-40 to +100	°C

Note. Above parameters are guaranteed independently.

ELECTRICAL CHARACTERISTICS (T_C=25°C, Z_G=Z_L=50 unless otherwise noted)

Symbol	Parameter	Test conditions	Limits		Unit
			Min	Max	
f	Frequency range		903	905	MHz
P _O	Output power	V _{DD} =6V, V _{GG} =5V, P _{in} =1mW, Z _G =Z _L =50	1.8		W
2f _o	2nd. harmonic			-30	dBc
in	Input VSWR			4	-
τ	Total efficiency	P _O =1.8W(V _{GG} =Adjust), V _{DD} =6V, P _{in} =1mW, Z _G =Z _L =50	30		%
-	Stability	Z _G =Z _L =50, V _{DD} =4.5-9.3V, Load VSWR <4:1	No parasitic oscillation		-
-	Load VSWR tolerance	V _{DD} =13V, P _{in} =1mW, P _O =1.8W (V _{GG} Adjust), Z _L =20:1	No degradation or destroy		-

Note. Above parameters, ratings, limits and test conditions are subject to change.