

FEATURES

- **Supply Current 150 μ A (Max per Amplifier) Guaranteed Over Temperature**
- **Offset Voltage 3 μ V (Max)**
- **Offset Voltage Drift 30nV/ $^{\circ}$ C (Max)**
- Common Mode Input Range from V^- to $V^+ - 0.5V$
- Output Swings Rail-to-Rail
- Voltage Gain: 140dB (Typ)
- PSRR and CMRR: 130dB (Typ)
- Input Bias Current: 1pA (Typ, 25 $^{\circ}$ C)
- Noise: 1.6 μ V_{P-P} (0.01Hz to 10Hz Typ)
- Supply Operation:
 - 2.7V to 6V (LTC2054/LTC2055)
 - 2.7V to $\pm 5.5V$ (LTC2054HV/LTC2055HV)
- Low Profile (1mm) SOT-23, MS8 and 3mm \times 3mm \times 0.8mm DFN Packages

APPLICATIONS

- Thermocouple Amplifiers
- Electronic Scales
- Medical Instrumentation
- Strain Gauge Amplifiers
- High Resolution Data Acquisition
- DC Accurate RC Active Filters
- Low Side Current Sense
- Battery-Powered Systems

DESCRIPTION

The LTC[®]2054/LTC2055 are low power, low noise single/dual zero-drift operational amplifiers available in the SOT-23 (ThinSOT[™]) and MS8 packages. For space limited applications, the LTC2055 is also available in a 3mm \times 3mm \times 0.8mm dual fine pitch leadless package (DFN). They operate from a single 2.7V minimum supply and support $\pm 5V$ applications. The current consumption is typically 150 μ A for the LTC2054 and 130 μ A/amp for the LTC2055.

The LTC2054/LTC2055, despite their miniature size, feature uncompromising DC performance. The typical input offset voltage and offset drift are 0.5 μ V and 25nV/ $^{\circ}$ C. The almost zero DC offset and drift are supported with a power supply rejection ratio (PSRR) and common mode rejection ratio (CMRR) of more than 130dB.

The input common mode voltage ranges from the negative supply up to typically 0.5V from the positive supply. The open-loop gain is typically 140dB. The LTC2054/LTC2055 also feature a 1.6 μ V_{P-P} DC to 10Hz noise and a 500kHz gain-bandwidth product.

LTC, LTC and LT are registered trademarks of Linear Technology Corporation.
ThinSOT is a trademark of Linear Technology Corporation

TYPICAL APPLICATION

-48V Low Side Precision Current Sense

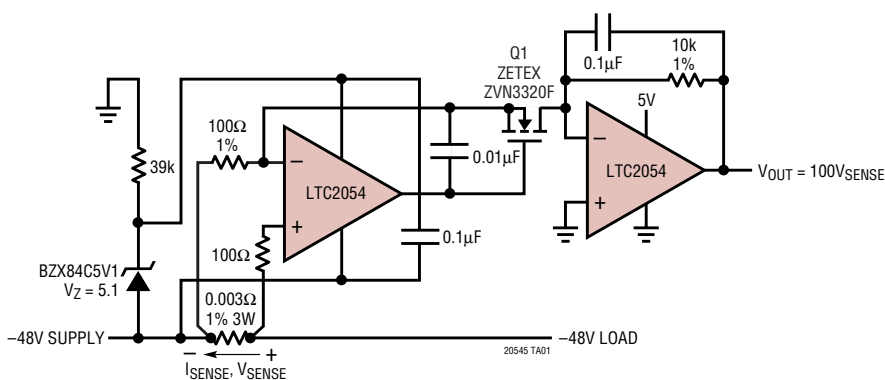

Supply Current (per Amplifier)

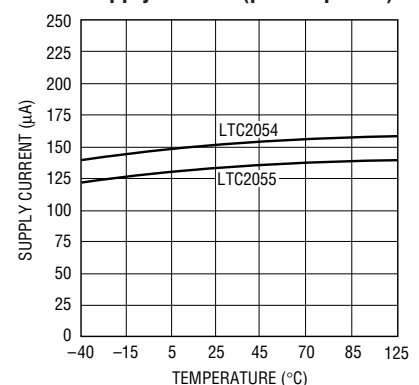

20545 TA01b

20545fa

LTC2054/LTC2055

ABSOLUTE MAXIMUM RATINGS (Note 1)

Total Supply Voltage (V^+ to V^-)	Operating Temperature Range	-40°C to 125°C
LTC2054/LTC2055	Specified Temperature Range (Note 3)	-40°C to 125°C
LTC2054HV/LTC2055HV	Storage Temperature Range	-65°C to 150°C
Input Voltage	DD Package	-65°C to 125°C
Input Current	Lead Temperature (Soldering, 10 sec)	300°C
Output Short-Circuit Duration		

PACKAGE/ORDER INFORMATION

<p>S5 PACKAGE 5-LEAD PLASTIC SOT-23 $T_{JMAX} = 150^{\circ}C, \theta_{JA} = 250^{\circ}C/W$</p>		<p>DD PACKAGE 8-LEAD (3mm x 3mm) PLASTIC DFN UNDERSIDE METAL INTERNALLY CONNECTED TO V^- (PCB CONNECTION OPTIONAL) $T_{JMAX} = 125^{\circ}C, \theta_{JA} = 160^{\circ}C/W, \text{NOTE 5}$</p>		<p>MS8 PACKAGE 8-LEAD PLASTIC MSOP $T_{JMAX} = 150^{\circ}C, \theta_{JA} = 200^{\circ}C/W$</p>	
ORDER PART NUMBER*	S5 PART MARKING	ORDER PART NUMBER*	DD PART MARKING	ORDER PART NUMBER*	MS8 PART MARKING
LTC2054CS5	LTAGB	LTC2055CDD	LBCW	LTC2055CMS8	LTBCR
LTC2054HVCS5	LTAGD	LTC2055HVCDD	LBCX	LTC2055HVCMS8	LTBCT
LTC2054IS5	LTAGB	LTC2055IDD	LBCW	LTC2055IMS8	LTBCR
LTC2054HVIS5	LTAGD	LTC2055HVIDD	LBCX	LTC2055HVIMS8	LTBCT
LTC2054HS5	LTAGB	LTC2055HDD	LBCW	LTC2055HMS8	LTBCR
LTC2054HVHS5	LTAGD	LTC2055HVHDD	LBCX	LTC2055HVHMS8	LTBCT

*The temperature grade (C, I or H) is indicated on the shipping container. Consult LTC Marketing for parts specified with wider operating temperature ranges.

ELECTRICAL CHARACTERISTICS (LTC2054/LTC2055, LTC2054HV/LTC2055HV) The ● denotes the specifications which apply over the full operating temperature range, otherwise specifications are at $T_A = 25^{\circ}C$. $V_S = 3V, 5V$ unless otherwise noted. (Note 3)

SYMBOL	PARAMETER	CONDITIONS	LTC2054C/LTC2055C LTC2054I/LTC2055I			LTC2054H/LTC2055H			UNITS
			MIN	TYP	MAX	MIN	TYP	MAX	
I_S	Supply Current (LTC2054)	No Load, $V_S = 3V$	●	140	175		140	180	μA
		No Load, $V_S = 5V$	●	150	175		150	180	μA
I_S	Supply Current Per Amplifier (LTC2055)	No Load, $V_S = 3V$	●	130	150		130	155	μA
		No Load, $V_S = 5V$	●	135	150		135	155	μA
V_{OS}	Input Offset Voltage	(Note 2)		± 0.5	± 3		± 0.5	± 3	μV
$\Delta V_{OS}/\Delta T$	Average Input Offset Drift	(Note 2)	●	0.02	± 0.03		0.02	± 0.05	$\mu V/^{\circ}C$
	Long-Term Offset Drift			50			50		nV/\sqrt{mO}
I_B	Input Bias Current (Note 4)	$V_S = 3V$		± 1			± 1		pA
		$V_S = 3V$	●		± 150			3000	pA
		$V_S = 5V$		± 1			± 1		pA
		$V_S = 5V$	●		± 150			3000	pA

20545fa

ELECTRICAL CHARACTERISTICS

(LTC2054/LTC2055, LTC2054HV/LTC2055HV) The ● denotes the specifications which apply over the full operating temperature range, otherwise specifications are at $T_A = 25^\circ\text{C}$. $V_S = 3\text{V}$, 5V unless otherwise noted. (Note 3)

SYMBOL	PARAMETER	CONDITIONS	LTC2054C/LTC2055C LTC2054I/LTC2055I			LTC2054H/LTC2055H			UNITS
			MIN	TYP	MAX	MIN	TYP	MAX	
I_{OS}	Input Offset Current (Note 4)	$V_S = 3\text{V}$ $V_S = 3\text{V}$	●		±2		±2		pA pA
		$V_S = 5\text{V}$ $V_S = 5\text{V}$	●		±2		±2		pA pA
e_n	Input Noise Voltage	$R_S = 100\Omega$, DC to 1Hz			0.6		0.6		μV_{P-P}
		$R_S = 100\Omega$, DC to 10Hz			1.6		1.6		μV_{P-P}
CMRR	Common Mode Rejection Ratio	$V_{CM} = \text{GND to } V^+ - 0.7\text{V}$ $V_S = 3\text{V}$	●	115 110	130	115 110	130		dB dB
		$V_{CM} = \text{GND to } V^+ - 0.7\text{V}$ $V_S = 5\text{V}$	●	120 115	130	120 115	130		dB dB
PSRR	Power Supply Rejection Ratio	$V_S = 2.7\text{V to } 6\text{V}$	●	120 115	130	120 115	130		dB dB
A_{VOL}	Large-Signal Voltage Gain	$R_L = 100\text{k}$, $V_S = 3\text{V}$, $V_{OUT} = V_S/2$	●	120 115	135	120 115	135		dB dB
		$R_L = 100\text{k}$, $V_S = 5\text{V}$, $V_{OUT} = V_S/2$	●	125 120	140	125 120	140		dB dB
V_{OUT}	Output Voltage Swing High	$R_L = 5\text{k to GND}$, $V_S = 3\text{V}$	●	2.87	2.89	2.87	2.89		V
		$R_L = 5\text{k to GND}$, $V_S = 3\text{V}$	●	2.85		2.84			V
		$R_L = 5\text{k to GND}$, $V_S = 5\text{V}$	●	4.80	4.83	4.80	4.83		V
		$R_L = 5\text{k to GND}$, $V_S = 5\text{V}$	●	4.75		4.70			V
		$R_L = 100\text{k to GND}$, $V_S = 3\text{V}$	●	2.98 2.975	2.99	2.98 2.97	2.99		V V
V_{OUT}	Output Voltage Swing Low	$R_L = 100\text{k to GND}$, $V_S = 3\text{V}$	●	4.985 4.980	4.99	4.985 4.970	4.99		V V
		$R_L = 100\text{k to GND}$, $V_S = 3\text{V}$	●						V
		$R_L = 5\text{k to GND}$, $V_S = 3\text{V}$	●		2	8 10	3	8 10	mV mV
		$R_L = 5\text{k to GND}$, $V_S = 5\text{V}$	●		2	8 10	3	8 10	mV mV
		$R_L = 5\text{k to GND}$, $V_S = 5\text{V}$	●		2	8 10	3	8 10	mV mV
SR	Slew Rate			0.5		0.5		V/ μs	
GBW	Gain Bandwidth Product			500		500		kHz	
f_S	Internal Sampling Frequency			1		1		kHz	

LTC2054/LTC2055

ELECTRICAL CHARACTERISTICS (LTC2054HV/LTC2055HV) The ● denotes the specifications which apply over the full operating temperature range, otherwise specifications are at $T_A = 25^\circ\text{C}$. $V_S = \pm 5\text{V}$ unless otherwise noted. (Note 3)

SYMBOL	PARAMETER	CONDITIONS		LTC2054HVC/LTC2055HVC LTC2054HVI/LTC2055HVI			LTC2054HVH/LTC2055HVH			UNITS
				MIN	TYP	MAX	MIN	TYP	MAX	
I_S	Supply Current	No Load (LTC2054)	●		175	210		175	215	μA
I_S	Supply Current (Per Amplifier)	No Load (LTC2055)	●		150	180		150	185	μA
V_{OS}	Input Offset Voltage	(Note 2)			± 0.5	± 5		± 0.5	± 5	μV
$\Delta V_{OS}/\Delta T$	Average Input Offset Drift	(Note 2)	●		0.025	± 0.03		0.025	± 0.05	$\mu\text{V}/^\circ\text{C}$
	Long-Term Offset Drift				50			50		$\text{nV}/\sqrt{\text{mo}}$
I_B	Input Bias Current (Note 4)		●		± 3	± 150		± 3	± 3000	pA pA
I_{OS}	Input Offset Current (Note 4)		●		± 6	± 300		± 6	± 700	pA pA
e_n	Input Noise Voltage	$R_S = 100\Omega$, DC to 1Hz $R_S = 100\Omega$, DC to 10Hz			0.6 1.6			0.6 1.6		$\mu\text{V}_{\text{P-P}}$ $\mu\text{V}_{\text{P-P}}$
CMRR	Common Mode Rejection Ratio	$V_{\text{CM}} = \text{GND to } V^+ - 0.9$	●		120 115	130		120 115	130	dB dB
PSRR	Power Supply Rejection Ratio	$V_S = 2.7\text{V to } 11\text{V}$	●		120 115	130		120 115	130	dB dB
AVOL	Large-Signal Voltage Gain	$R_L = 100\text{k}$, $V_{\text{OUT}} = \text{GND}$	●		125 120	140		125 120	140	dB dB
V_{OUT}	Maximum Output Voltage Swing	$R_L = 5\text{k to GND}$ $R_L = 5\text{k to GND}$	●		± 4.78 ± 4.75	± 4.82		± 4.78 ± 4.70	± 4.82	V V
		$R_L = 100\text{k to GND}$ $R_L = 100\text{k to GND}$	●		± 4.98 ± 4.975	± 4.99		± 4.98 ± 4.97	± 4.99	V V
SR	Slew Rate				0.5			0.5		$\text{V}/\mu\text{s}$
GBW	Gain Bandwidth Product				500			500		kHz
f_S	Internal Sampling Frequency				1			1		kHz

Note 1: Absolute Maximum Ratings are those values beyond which the life of the device may be impaired.

Note 2: These parameters are guaranteed by design. Thermocouple effects preclude measurements of these voltage levels during automated testing.

Note 3: All versions of the LTC2054/LTC2055 are designed, characterized and expected to meet the extended temperature limits of -40°C and 125°C . The LTC2054C/LTC2055C/LTC2054HVC/LTC2055HVC are guaranteed to meet the temperature limits of 0°C and 70°C . The LTC2054I/LTC2055I/LTC2054HVI/LTC2055HVI are guaranteed to meet temperature

limits of -40°C and 85°C . The LTC2054H/LTC2055HVH and LTC2054H/LTC2055HVH are guaranteed to meet the temperature limits of -40°C and 125°C .

Note 4: Limit is determined by high speed automated test capability. See Typical Characteristic curves for actual typical performance. For tighter specifications, please consult Linear Technology Marketing.

Note 5: The θ_{JA} specified for the DD package is with minimal PCB heat spreading metal. Using expanded metal area on all layers of a board reduces this value.

TYPICAL PERFORMANCE CHARACTERISTICS

Common Mode Rejection Ratio vs Frequency

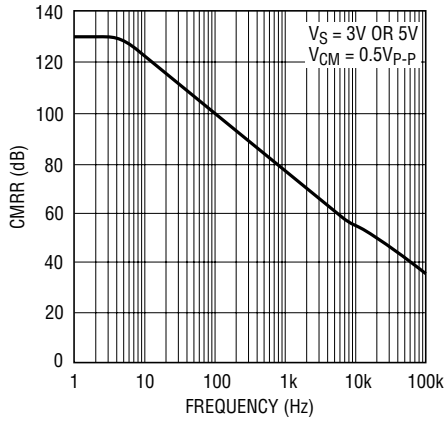

20545 G01

DC CMRR vs Common Mode Input Range

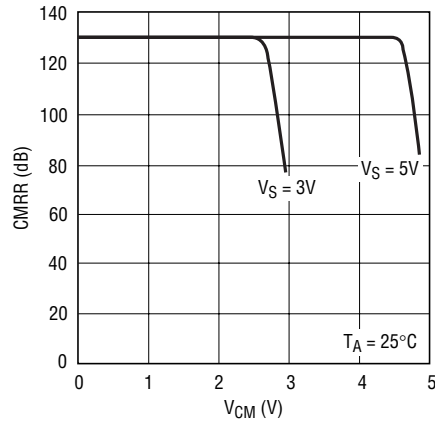

20545 G02

PSRR vs Frequency

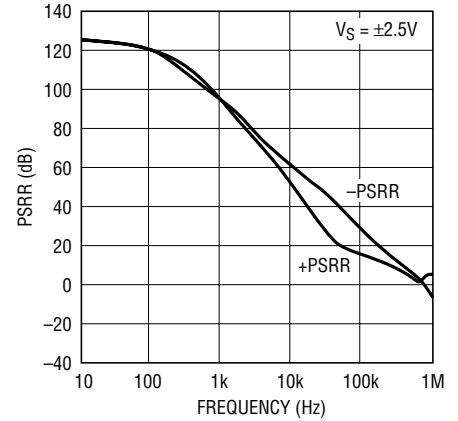

20545 G03

Output Voltage Swing vs Load Resistance

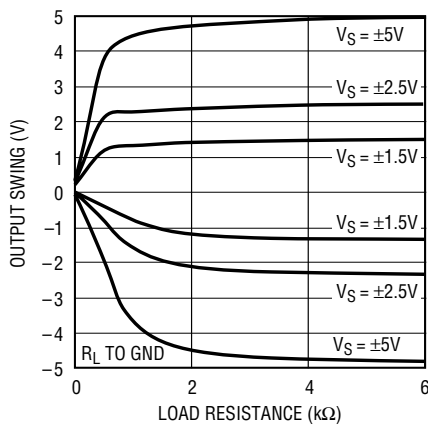

20545 G04

Output Swing vs Load Current

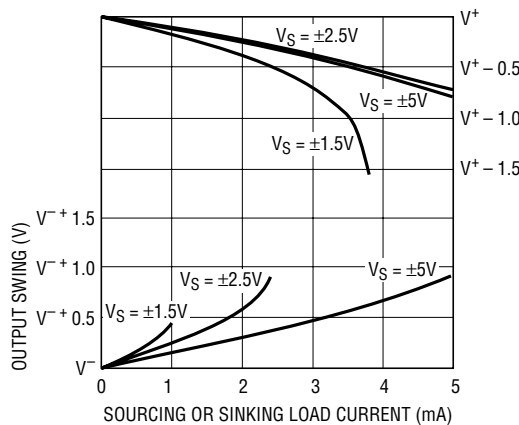

20545 G06

Short-Circuit Output Current vs Supply Voltage

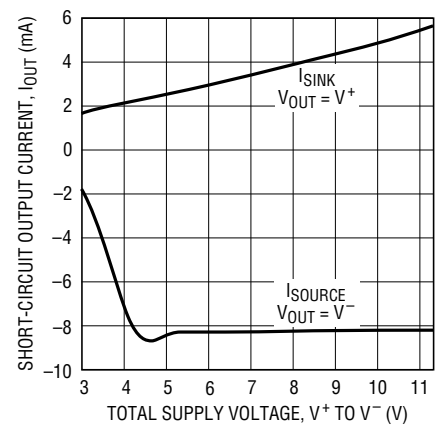

20545 G14

Gain/Phase vs Frequency

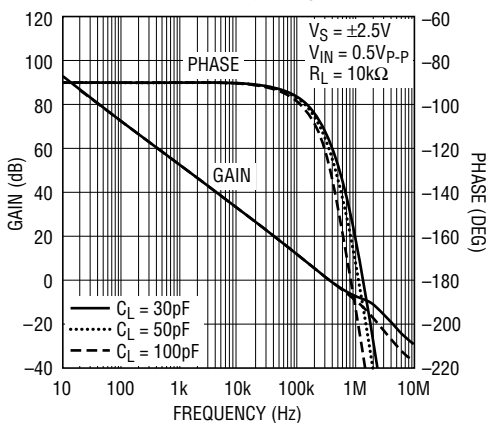

20545 G07

Input Bias Current vs Temperature

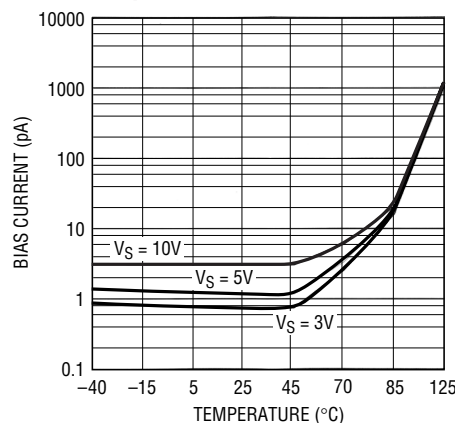

20545 G08

Input Bias Current vs Input Common Mode Voltage

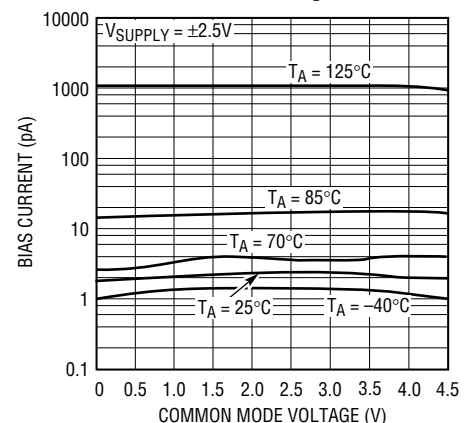

20545 G09

TYPICAL PERFORMANCE CHARACTERISTICS

Transient Response

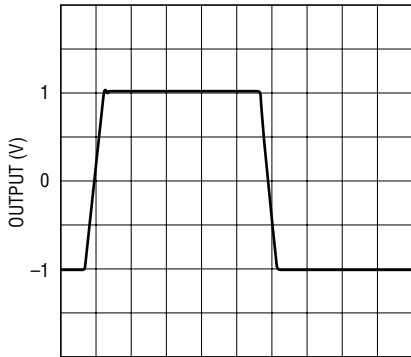

$A_V = 1$
 $R_L = 100k$
 $C_L = 50pF$
 $V_S = \pm 2.5V$
 $V_{IN} = 10kHz\ 2V_{p-p}$

20545 G10

Output Overload Recovery

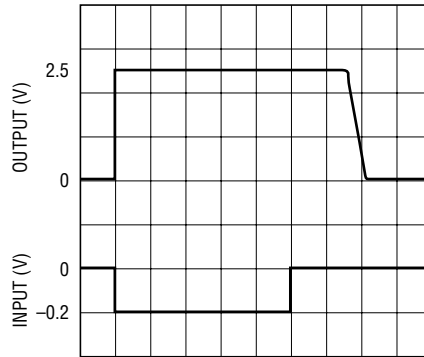

$A_V = -100$
 $R_L = 100k$
 $V_S = \pm 2.5V$

20545 G11

Output Overload Recovery

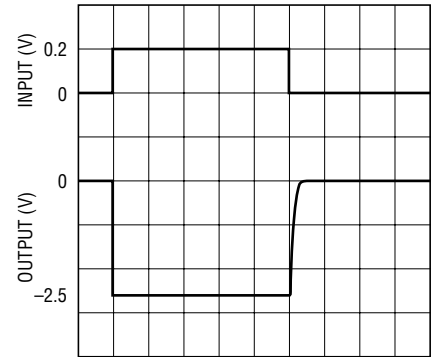

$A_V = -100$
 $R_L = 100k$
 $V_S = \pm 2.5V$

20545 G12

Common Mode Input Range vs Supply Voltage

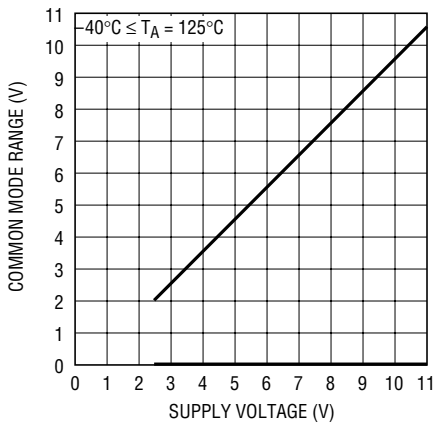

$-40^\circ C \leq T_A \leq 125^\circ C$

20545 G13

LTC2054 Supply Current vs Supply Voltage

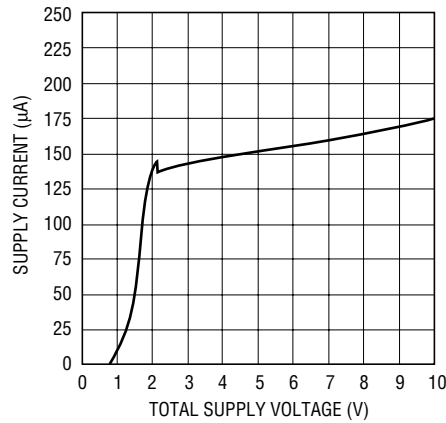

20545 G15

LTC2054 Supply Current vs Temperature

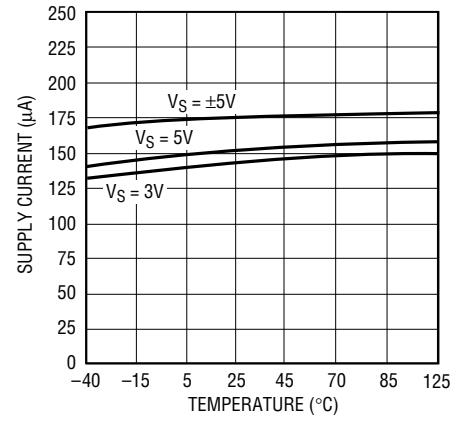

20545 G16

LTC2055 Supply Current (Per Amplifier) vs Supply Voltage

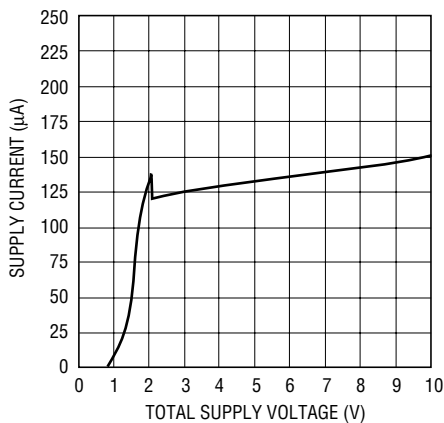

20545 G17

LTC2055 Supply Current (Per Amplifier) vs Temperature

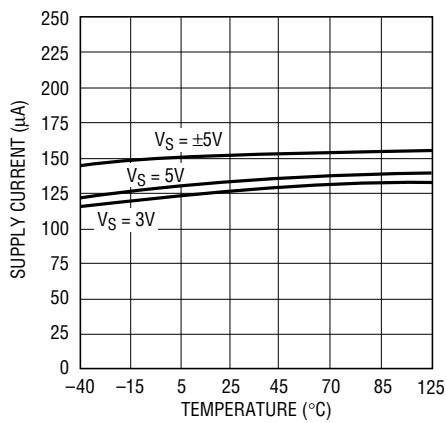

20545 G18

Noise Spectrum

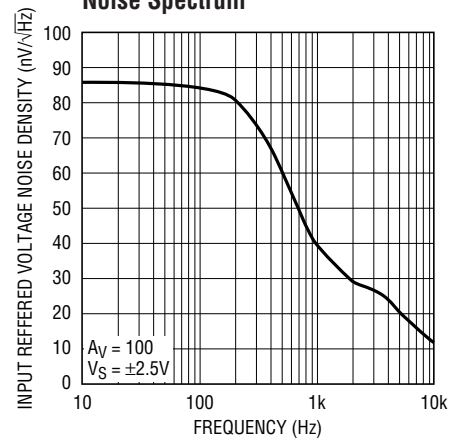

20545 G19

20545fa

TEST CIRCUITS

Electrical Characteristics
Test Circuit

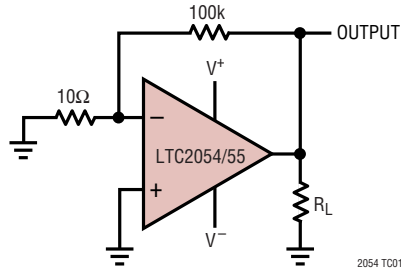

DC-10Hz Noise Test Circuit

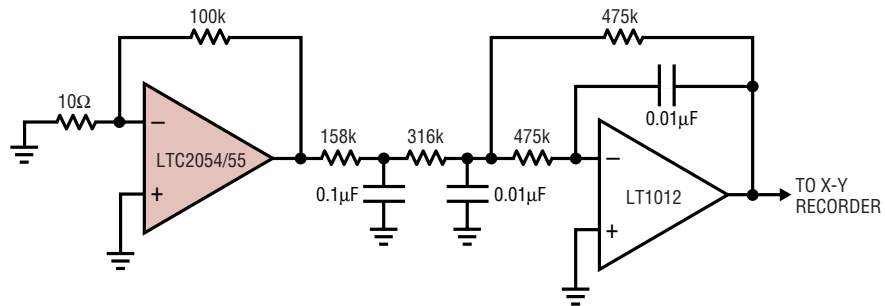

APPLICATIONS INFORMATION

Clock Feedthrough, Input Bias Current

The LTC2054 and LTC2055 use auto-zeroing circuitry to achieve an almost zero DC offset over temperature, common mode voltage, and power supply voltage. The frequency of the clock used for auto-zeroing is typically 1.0kHz. The term clock feedthrough is broadly used to indicate visibility of this clock frequency in the op amp output spectrum. There are typically two types of clock feedthrough in auto zeroed op amps like the LTC2054/LTC2055.

The first form of clock feedthrough is caused by the settling of the internal sampling capacitor and is input referred; that is, it is multiplied by the closed loop gain of the op amp. This form of clock feedthrough is independent of the magnitude of the input source resistance or the magnitude of the gain setting resistors. The LTC2054/LTC2055 have a residue clock feedthrough of less than $0.2\mu\text{V}_{\text{RMS}}$ input referred at 1.0kHz.

The second form of clock feedthrough is caused by the small amount of charge injection occurring during the sampling and holding of the op amp's input offset voltage. The current spikes are multiplied by the impedance seen at the input terminals of the op amp, appearing at the output multiplied by the closed loop gain of the op amp. To reduce this form of clock feedthrough, use smaller valued gain setting resistors and minimize the source resistance at the input. If the resistance seen at the inputs is less than 10k, this form of clock feedthrough is less than the amount of residue clock feedthrough from the first form described above.

Placing a capacitor across the feedback resistor reduces either form of clock feedthrough by limiting the bandwidth of the closed loop gain.

Input bias current is defined as the DC current into the input pins of the op amp. The same current spikes that

LTC2054/LTC2055 DC to 1Hz Noise

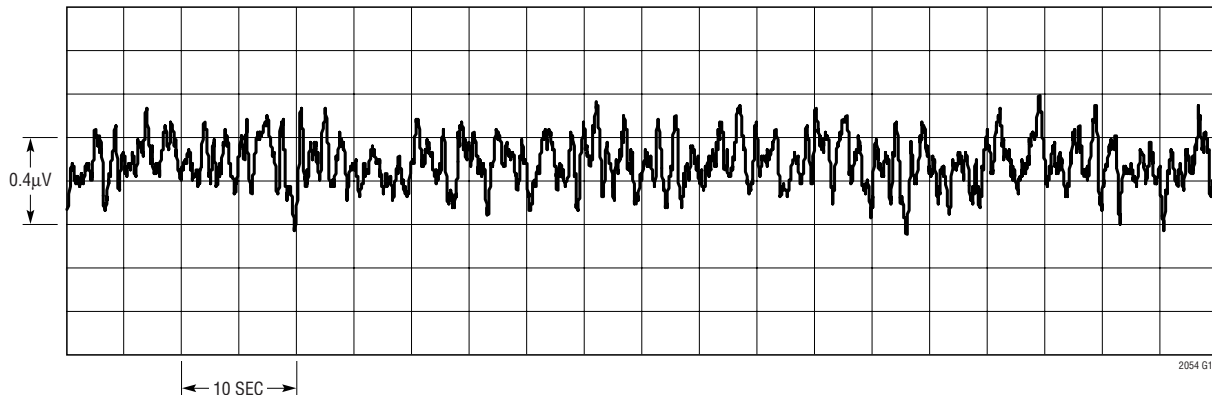

LTC2054/LTC2055 DC to 10Hz Noise

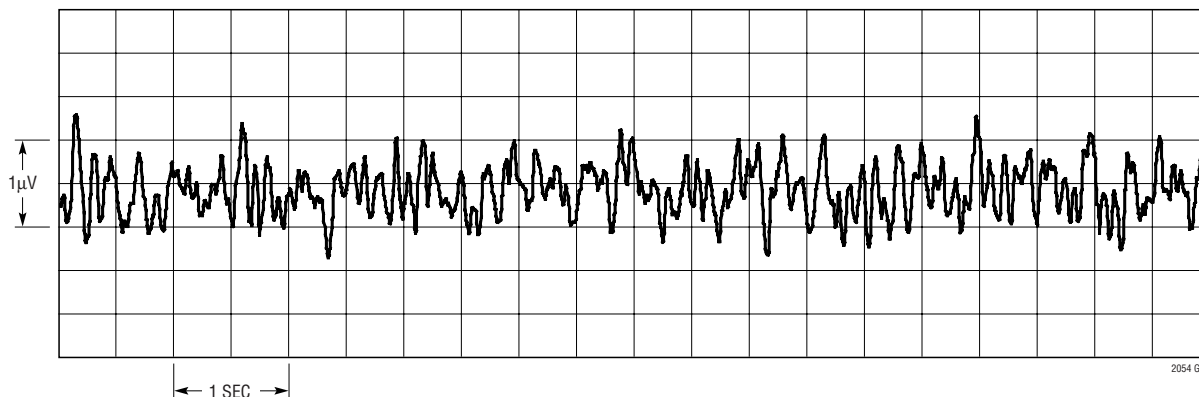

20545fa

APPLICATIONS INFORMATION

cause the second form of clock feedthrough described above, when averaged, dominate the DC input bias current of the op amp below 70°C.

At temperatures above 70°C, the leakage of the ESD protection diodes on the inputs increases the input bias currents of both inputs in the positive direction, while the current caused by the charge injection stays relatively constant. At elevated temperatures (above 70°C) the leakage current begins to dominate and both the negative and positive pins' input bias currents are in the positive direction (into the pins).

Extended Common Mode Range

The LTC2054/LTC2055 input stage is designed to allow nearly rail-to-rail input common mode signals. In addition, signals that extend beyond the allowed input common mode range do not cause output phase inversion.

Voltage Follower with Input Exceeding the Common Mode Range

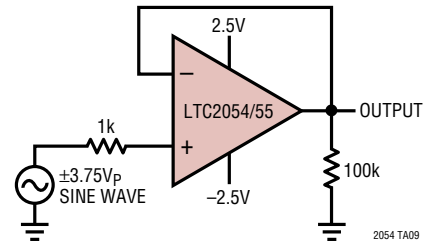

LTC2054/LTC2055 Extended Common Mode Range

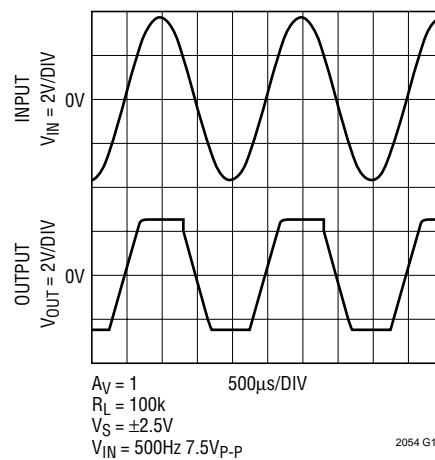

TYPICAL APPLICATIONS

Simple Differential Bridge Amplifier

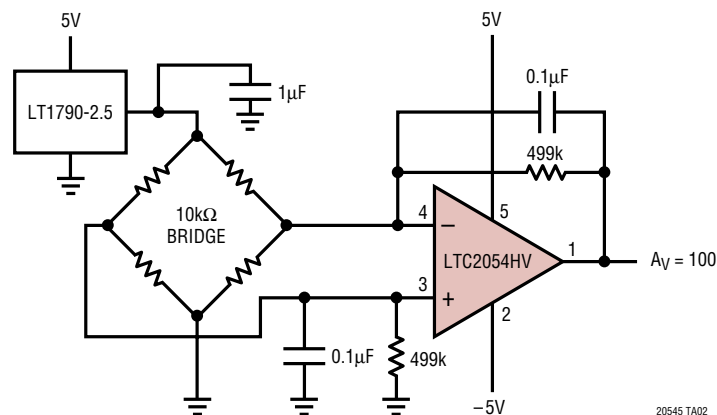

TYPICAL APPLICATIONS

Ground Referred Precision Current Sources

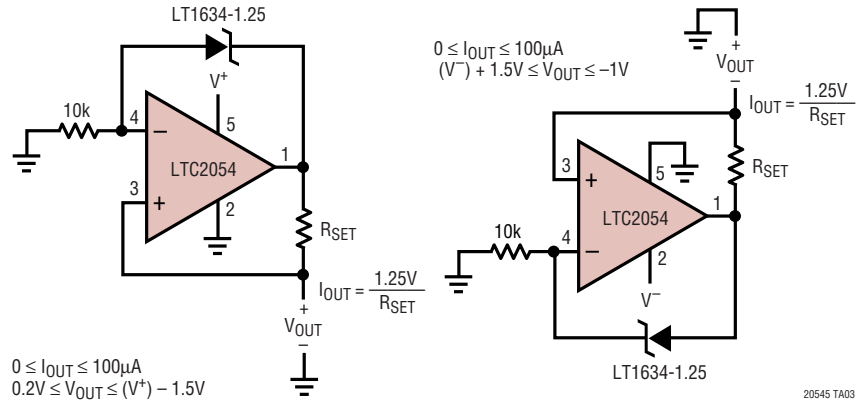

Instrumentation Amplifier with 100V Common Mode Input Voltage

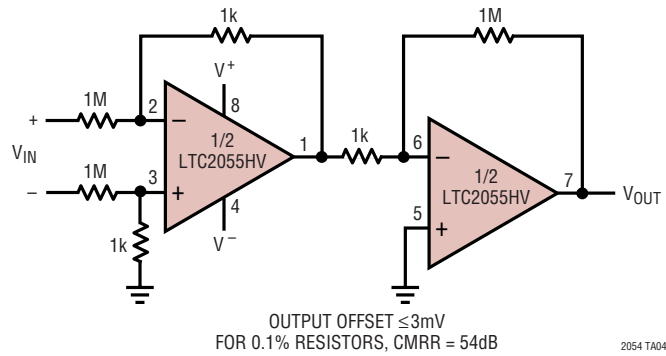

Gain of 1001 Single Supply Instrumentation Amplifier

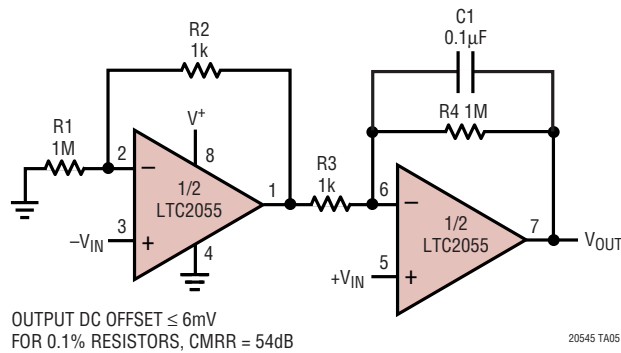

PACKAGE DESCRIPTION

DD Package 8-Lead Plastic DFN (3mm × 3mm) (Reference LTC DWG # 05-08-1698)

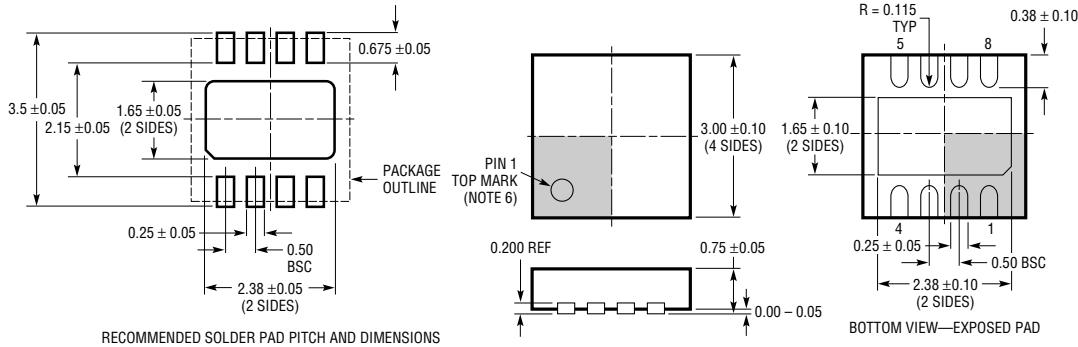

- NOTE:
1. DRAWING TO BE MADE A JEDEC PACKAGE OUTLINE M0-229 VARIATION OF (WEED-1)
 2. DRAWING NOT TO SCALE
 3. ALL DIMENSIONS ARE IN MILLIMETERS
 4. DIMENSIONS OF EXPOSED PAD ON BOTTOM OF PACKAGE DO NOT INCLUDE MOLD FLASH. MOLD FLASH, IF PRESENT, SHALL NOT EXCEED 0.15mm ON ANY SIDE
 5. EXPOSED PAD SHALL BE SOLDER PLATED
 6. SHADED AREA IS ONLY A REFERENCE FOR PIN 1 LOCATION ON TOP AND BOTTOM OF PACKAGE

(008) DFN 1203

MS8 Package 8-Lead Plastic MSOP (Reference LTC DWG # 05-08-1660)

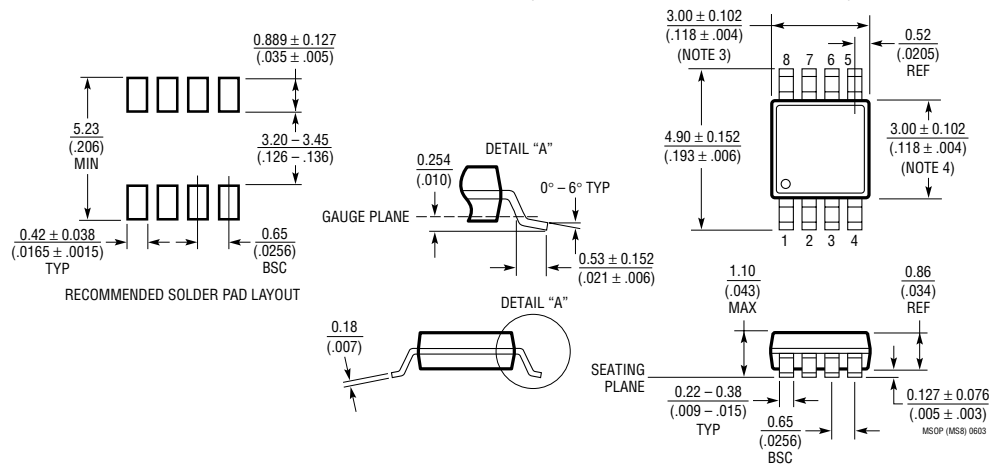

- NOTE:
1. DIMENSIONS IN MILLIMETER/(INCH)
 2. DRAWING NOT TO SCALE
 3. DIMENSION DOES NOT INCLUDE MOLD FLASH, PROTRUSIONS OR GATE BURRS. MOLD FLASH, PROTRUSIONS OR GATE BURRS SHALL NOT EXCEED 0.152mm (.006") PER SIDE
 4. DIMENSION DOES NOT INCLUDE INTERLEAD FLASH OR PROTRUSIONS. INTERLEAD FLASH OR PROTRUSIONS SHALL NOT EXCEED 0.152mm (.006") PER SIDE
 5. LEAD COPLANARITY (BOTTOM OF LEADS AFTER FORMING) SHALL BE 0.102mm (.004") MAX

S5 Package 5-Lead Plastic TSOT-23 (Reference LTC DWG # 05-08-1635)

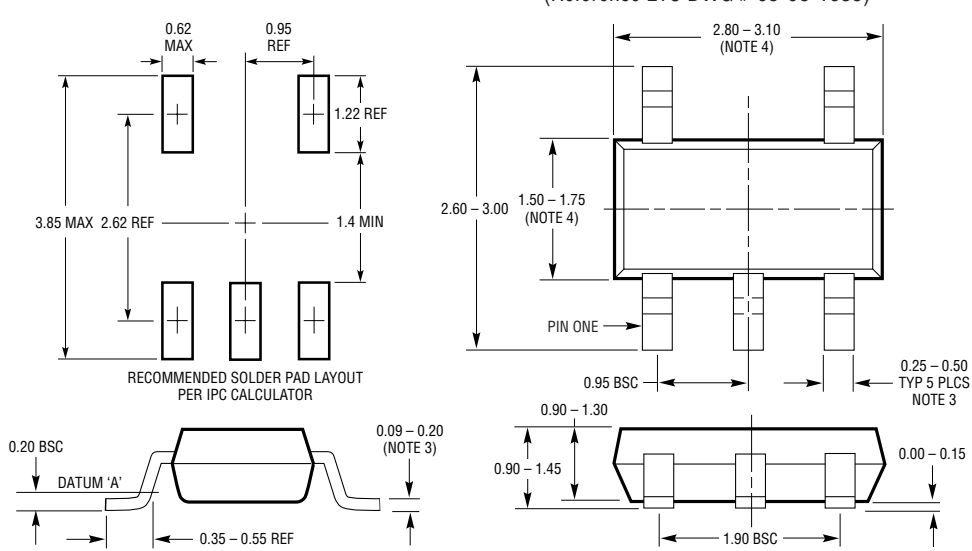

- NOTE:
1. DIMENSIONS ARE IN MILLIMETERS
 2. DRAWING NOT TO SCALE
 3. DIMENSIONS ARE INCLUSIVE OF PLATING
 4. DIMENSIONS ARE EXCLUSIVE OF MOLD FLASH AND METAL BURR
 5. MOLD FLASH SHALL NOT EXCEED 0.254mm
 6. PACKAGE EIAJ REFERENCE IS SC-74A (EIAJ)

ATTENTION: ORIGINAL SOT23-5L PACKAGE.
MOST SOT23-5L PRODUCTS CONVERTED TO THIN SOT23 PACKAGE, DRAWING # 05-08-1635 AFTER APPROXIMATELY APRIL 2001 SHIP DATE

S5 SOT-23 0502

TYPICAL APPLICATIONS

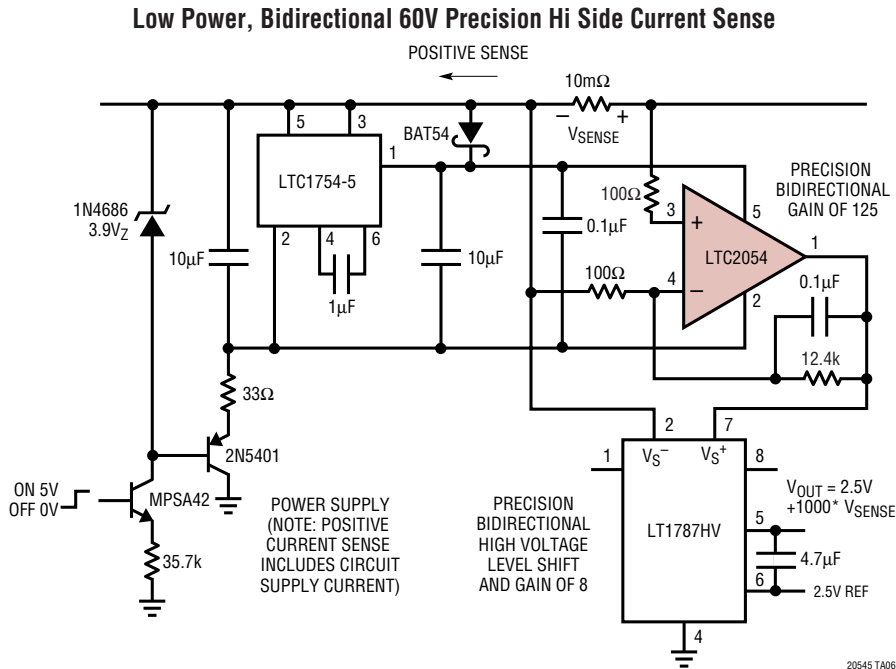

Precision Low Drift Integrator

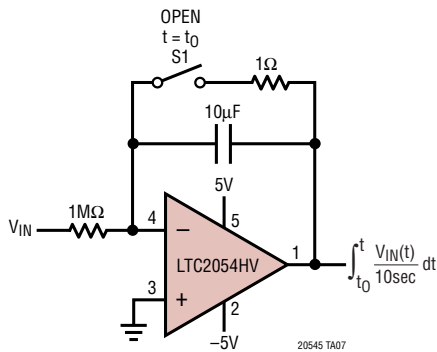

**Ultra-Precision, Wide Dynamic Range
10Hz Bandwidth Photodiode Amplifier**

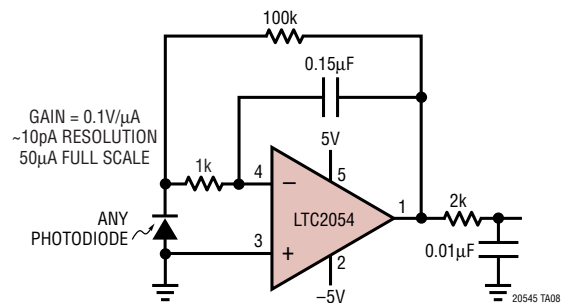

RELATED PARTS

PART NUMBER	DESCRIPTION	COMMENTS
LTC1049	Low Power Zero-Drift Op Amp	Low Supply Current 200μA
LTC1050	Precision Zero-Drift Op Amp	Single Supply Operation 4.75V to 16V, Noise Tested and Guaranteed
LTC1051/LTC1053	Precision Zero-Drift Op Amp	Dual/Quad Version of the LTC1050
LTC1150	±15V Zero-Drift Op Amp	High Voltage Operation ±18V
LTC1152	Rail-to-Rail Input and Output Zero-Drift Op Amp	Single Zero-Drift Op Amp with Rail-to-Rail Input and Output and Shutdown
LT1677	Low Noise Rail-to-Rail Input and Output Precision Op Amp	$V_{OS} = 90\mu V$, $V_S = 2.7V$ to 44V
LT1884/LT1885	Rail-to-Rail Output Precision Op Amp	$V_{OS} = 50\mu V$, $I_B = 400pA$, $V_S = 2.7V$ to 40V
LTC2050	Zero-Drift Op Amp	Enhanced Output Drive Capability
LTC2051/LTC2052	Dual/Quad Zero-Drift Op Amp	Dual/Quad Version of the LTC2050 in MS8/GN16 Package
LTC2053	Zero-Drift Instrumentation Amp	Rail-to-Rail Input