

TOSHIBA CMOS DIGITAL INTEGRATED CIRCUIT SILICON MONOLITHIC

**TC74VCX2125FT****LOW-VOLTAGE QUAD BUS BUFFER  
WITH 3.6 V TOLERANT INPUTS AND OUTPUTS**

The TC74VCX2125FT is a high performance CMOS QUAD BUS BUFFER. Designed for use in 1.8, 2.5 or 3.3 Volt systems, it achieves high speed operation while maintaining the CMOS low power dissipation. It is also designed with over voltage tolerant inputs and outputs up to 3.6V. This device requires the 3-state control input  $\overline{OE}$  to be set high to place the output into the high impedance state. The 26- $\Omega$  series resistor helps reducing output overshoot and undershoot without external resistor. All inputs are equipped with protection circuits against static discharge.

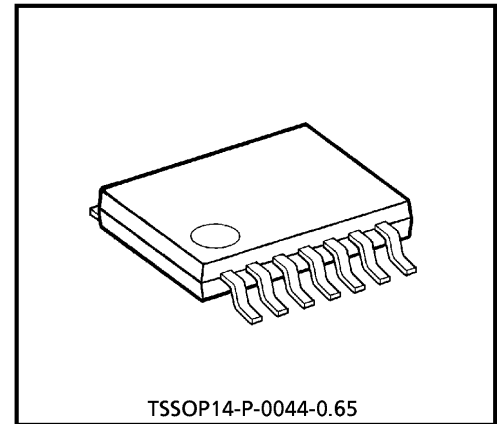

Weight : 0.06 g (Typ.)

**FEATURES**

- 26- $\Omega$  Series Resistors on Outputs
- Low Voltage Operation:  $V_{CC} = 1.8\sim 3.6$  V
- High Speed Operation :  $t_{pd} = 3.7$  ns (max) at  $V_{CC} = 3.0\sim 3.6$  V  
 $t_{pd} = 4.8$  ns (max) at  $V_{CC} = 2.3\sim 2.7$  V  
 $t_{pd} = 9.6$  ns (max) at  $V_{CC} = 1.8$  V
- 3.6V Tolerant inputs and outputs.
- Output Current :  $I_{OH}/I_{OL} = \pm 12$  mA (min) at  $V_{CC} = 3.0$  V  
 $I_{OH}/I_{OL} = \pm 8$  mA (min) at  $V_{CC} = 2.3$  V  
 $I_{OH}/I_{OL} = \pm 4$  mA (min) at  $V_{CC} = 1.8$  V
- Latch-up Performance :  $\pm 300$  mA
- ESD Performance : Human Body Model  $> \pm 2000$  V  
Machine Model  $> \pm 200$  V
- Package : TSSOP  
(Thin Shrink Small Outline Package)
- Power Down Protection is provided on all inputs and outputs.
- Supports live insertion/withdrawal (Note 1)  
(Note 1) : To ensure the high-impedance state during power up or power down,  $\overline{OE}$  should be tied to  $V_{CC}$  through a pullup resistor; the minimum value of the resistor is determined by the current-sourcing capability of the driver.

980910EBA1

- TOSHIBA is continually working to improve the quality and the reliability of its products. Nevertheless, semiconductor devices in general can malfunction or fail due to their inherent electrical sensitivity and vulnerability to physical stress. It is the responsibility of the buyer, when utilizing TOSHIBA products, to observe standards of safety, and to avoid situations in which a malfunction or failure of a TOSHIBA product could cause loss of human life, bodily injury or damage to property. In developing your designs, please ensure that TOSHIBA products are used within specified operating ranges as set forth in the most recent products specifications. Also, please keep in mind the precautions and conditions set forth in the TOSHIBA Semiconductor Reliability Handbook.
- The products described in this document are subject to the foreign exchange and foreign trade laws.
- The information contained herein is presented only as a guide for the applications of our products. No responsibility is assumed by TOSHIBA CORPORATION for any infringements of intellectual property or other rights of the third parties which may result from its use. No license is granted by implication or otherwise under any intellectual property or other rights of TOSHIBA CORPORATION or others.
- The information contained herein is subject to change without notice.

**PIN ASSIGNMENT**

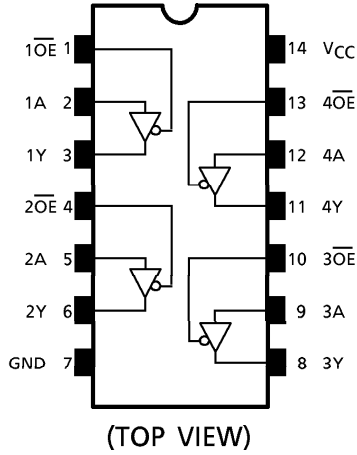

**IEC LOGIC SYMBOL**

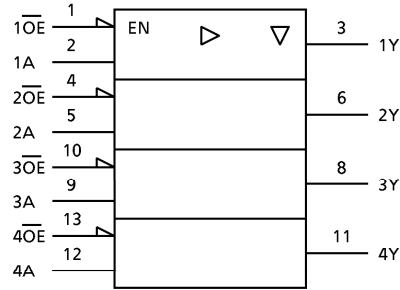

**TRUTH TABLE**

| INPUTS          |   | OUTPUTS |
|-----------------|---|---------|
| $\overline{OE}$ | A | Y       |
| H               | X | Z       |
| L               | L | L       |
| L               | H | H       |

X : Don't Care  
Z : High Impedance

**MAXIMUM RATINGS**

| PARAMETER                   | SYMBOL           | RATING                        | UNIT |
|-----------------------------|------------------|-------------------------------|------|
| Power Supply Voltage        | $V_{CC}$         | -0.5~4.6                      | V    |
| DC Input Voltage            | $V_{IN}$         | -0.5~4.6                      | V    |
| DC Output Voltage           | $V_{OUT}$        | -0.5~4.6 (Note 1)             | V    |
|                             |                  | -0.5~ $V_{CC}$ + 0.5 (Note 2) |      |
| Input Diode Current         | $I_{IK}$         | -50                           | mA   |
| Output Diode Current        | $I_{OK}$         | ±50 (Note 3)                  | mA   |
| DC Output Current           | $I_{OUT}$        | ±50                           | mA   |
| Power Dissipation           | $P_D$            | 180                           | mW   |
| DC $V_{CC}$ /Ground Current | $I_{CC}/I_{GND}$ | ±100                          | mA   |
| Storage Temperature         | $T_{stg}$        | -65~150                       | °C   |

(Note 1) : Off-State

(Note 2) : High or Low State.  $I_{OUT}$  absolute maximum rating must be observed.

(Note 3) :  $V_{OUT} < GND$ ,  $V_{OUT} > V_{CC}$

## RECOMMENDED OPERATING RANGE

| PARAMETER                | SYMBOL          | RATING               | UNIT |
|--------------------------|-----------------|----------------------|------|
| Supply Voltage           | $V_{CC}$        | 1.8~3.6              | V    |
|                          |                 | 1.2~3.6 (Note 4)     |      |
| Input Voltage            | $V_{IN}$        | -0.3~3.6             | V    |
| Output Voltage           | $V_{OUT}$       | 0~3.6 (Note 5)       | V    |
|                          |                 | 0~ $V_{CC}$ (Note 6) |      |
| Output Current           | $I_{OH}/I_{OL}$ | $\pm 12$ (Note 7)    | mA   |
|                          |                 | $\pm 8$ (Note 8)     |      |
|                          |                 | $\pm 4$ (Note 9)     |      |
| Operating Temperature    | $T_{opr}$       | -40~85               | °C   |
| Input Rise And Fall Time | dt/dv           | 0~10 (Note 10)       | ns/V |

(Note 4) : Data Retention Only

(Note 5) : Off-State

(Note 6) : High or Low State

(Note 7) :  $V_{CC} = 3.0\sim 3.6\text{ V}$ (Note 8) :  $V_{CC} = 2.3\sim 2.7\text{ V}$ (Note 9) :  $V_{CC} = 1.8\text{ V}$ (Note 10) :  $V_{IN} = 0.8\sim 2.0\text{ V}$ ,  $V_{CC} = 3.0\text{ V}$ 

## ELECTRICAL CHARACTERISTICS

DC characteristics ( $T_a = -40\sim 85^\circ\text{C}$ ,  $2.7\text{ V} < V_{CC} \leq 3.6\text{ V}$ )

| PARAMETER                        | SYMBOL          | TEST CONDITION  | $V_{CC}$ (V)                  | MIN                          | MAX        | UNIT           |      |
|----------------------------------|-----------------|---|-------------------------------|------------------------------|------------|----------------|------|
|                                  |                 |   |                               |                              |            |                |      |
| Input Voltage                    | "H" Level       | $V_{IH}$  | 2.7~3.6                       | 2.0                          | —          | V              |      |
|                                  | "L" Level       | $V_{IL}$  | 2.7~3.6                       | —                            | 0.8        |                |      |
| Output Voltage                   | "H" Level       | $V_{OH}$  | $V_{IN} = V_{IH}$ or $V_{IL}$ | $I_{OH} = -100\ \mu\text{A}$ | 2.7~3.6    | $V_{CC} - 0.2$ | V    |
|                                  |                 |   |                               | $I_{OH} = -6\text{ mA}$      | 2.7        | 2.2            |      |
|                                  |                 |   |                               | $I_{OH} = -8\text{ mA}$      | 3.0        | 2.4            |      |
|                                  |                 |   |                               | $I_{OH} = -12\text{ mA}$     | 3.0        | 2.2            |      |
|                                  | "L" Level       | $V_{OL}$  | $V_{IN} = V_{IH}$ or $V_{IL}$ | $I_{OL} = 100\ \mu\text{A}$  | 2.7~3.6    | —              | 0.2  |
|                                  |                 |   |                               | $I_{OL} = 6\text{ mA}$       | 2.7        | —              | 0.4  |
|                                  |                 |   |                               | $I_{OL} = 8\text{ mA}$       | 3.0        | —              | 0.55 |
|                                  |                 |   |                               | $I_{OL} = 12\text{ mA}$      | 3.0        | —              | 0.8  |
| Input Leakage Current            | $I_{IN}$        | $V_{IN} = 0\sim 3.6\text{ V}$                                   | 2.7~3.6                       | —                            | $\pm 5.0$  | $\mu\text{A}$  |      |
| 3-State Output Off-State Current | $I_{OZ}$        | $V_{IN} = V_{IH}$ or $V_{IL}$<br>$V_{OUT} = 0\sim 3.6\text{ V}$ | 2.7~3.6                       | —                            | $\pm 10.0$ | $\mu\text{A}$  |      |
| Power Off Leakage Current        | $I_{OFF}$       | $V_{IN}, V_{OUT} = 0\sim 3.6\text{ V}$                          | 0                             | —                            | 10.0       | $\mu\text{A}$  |      |
| Quiescent Supply Current         | $I_{CC}$        | $V_{IN} = V_{CC}$ or GND  | 2.7~3.6                       | —                            | 20.0       | $\mu\text{A}$  |      |
|                                  |                 | $V_{CC} \leq (V_{IN}, V_{OUT}) \leq 3.6\text{ V}$               | 2.7~3.6                       | —                            | $\pm 20.0$ |                |      |
| Increase In $I_{CC}$ Per Input   | $\Delta I_{CC}$ | $V_{IH} = V_{CC} - 0.6\text{ V}$                                | 2.7~3.6                       | —                            | 750        | $\mu\text{A}$  |      |

**ELECTRICAL CHARACTERISTICS**

DC characteristics (Ta = -40~85°C, 2.3 V ≤ V<sub>CC</sub> ≤ 2.7 V)

| PARAMETER                        |           | SYMBOL           | TEST CONDITION   | V <sub>CC</sub> (V)       | MIN     | MAX                   | UNIT |
|----------------------------------|-----------|------------------|--|---------------------------|---------|-----------------------|------|
|                                  |           |                  |  |                           |         |                       |      |
| Input Voltage                    | "H" Level | V <sub>IH</sub>  |  | 2.3~2.7                   | 1.6     | —                     | V    |
|                                  | "L" Level | V <sub>IL</sub>  |  | 2.3~2.7                   | —       | 0.7                   |      |
| Output Voltage                   | "H" Level | V <sub>OH</sub>  | V <sub>IN</sub> = V <sub>IH</sub> or V <sub>IL</sub>                               | I <sub>OH</sub> = -100 μA | 2.3~2.7 | V <sub>CC</sub> - 0.2 | V    |
|                                  |           |                  |  | I <sub>OH</sub> = -4 mA   | 2.3     | 2.0                   |      |
|                                  |           |                  |  | I <sub>OH</sub> = -6 mA   | 2.3     | 1.8                   |      |
|                                  |           |                  |  | I <sub>OH</sub> = -8 mA   | 2.3     | 1.7                   |      |
|                                  | "L" Level | V <sub>OL</sub>  | V <sub>IN</sub> = V <sub>IH</sub> or V <sub>IL</sub>                               | I <sub>OL</sub> = 100 μA  | 2.3~2.7 | —                     | 0.2  |
|                                  |           |                  |  | I <sub>OL</sub> = 6 mA    | 2.3     | —                     | 0.4  |
|                                  |           |                  | I <sub>OL</sub> = 8 mA   | 2.3                       | —       | 0.6                   |      |
| Input Leakage Current            |           | I <sub>IN</sub>  | V <sub>IN</sub> = 0~3.6 V  | 2.3~2.7                   | —       | ± 5.0                 | μA   |
| 3-State Output Off-State Current |           | I <sub>OZ</sub>  | V <sub>IN</sub> = V <sub>IH</sub> or V <sub>IL</sub><br>V <sub>OUT</sub> = 0~3.6 V | 2.3~2.7                   | —       | ± 10.0                | μA   |
| Power Off Leakage Current        |           | I <sub>OFF</sub> | V <sub>IN</sub> , V <sub>OUT</sub> = 0~3.6 V                                       | 0                         | —       | 10.0                  | μA   |
| Quiescent Supply Current         |           | I <sub>CC</sub>  | V <sub>IN</sub> = V <sub>CC</sub> or GND   | 2.3~2.7                   | —       | 20.0                  | μA   |
|                                  |           |                  | V <sub>CC</sub> ≤ (V <sub>IN</sub> , V <sub>OUT</sub> ) ≤ 3.6 V                    | 2.3~2.7                   | —       | ± 20.0                |      |

**ELECTRICAL CHARACTERISTICS**

DC characteristics (Ta = -40~85°C, 1.8 V ≤ VCC < 2.3 V)

| PARAMETER                        |           | SYMBOL           | TEST CONDITION   |                           | VCC (V) | MIN                   | MAX                   | UNIT |
|----------------------------------|-----------|------------------|--|---------------------------|---------|-----------------------|-----------------------|------|
|                                  |           |                  |  |                           |         |                       |                       |      |
| Input Voltage                    | "H" Level | V <sub>IH</sub>  |  |                           | 1.8~2.3 | 0.7 × V <sub>CC</sub> | —                     | V    |
|                                  | "L" Level | V <sub>IL</sub>  |  |                           | 1.8~2.3 | —                     | 0.2 × V <sub>CC</sub> |      |
| Output Voltage                   | "H" Level | V <sub>OH</sub>  | V <sub>IN</sub> = V <sub>IH</sub> or V <sub>IL</sub>                               | I <sub>OH</sub> = -100 μA | 1.8     | V <sub>CC</sub> - 0.2 | —                     | V    |
|                                  |           |                  |  | I <sub>OH</sub> = -4 mA   | 1.8     | 1.4                   | —                     |      |
|                                  | "L" Level | V <sub>OL</sub>  | V <sub>N</sub> = V <sub>IH</sub> or V <sub>IL</sub>                                | I <sub>OL</sub> = 100 μA  | 1.8     | —                     | 0.2                   |      |
|                                  |           |                  |  | I <sub>OL</sub> = 4 mA    | 1.8     | —                     | 0.3                   |      |
| Input Leakage Current            |           | I <sub>IN</sub>  | V <sub>IN</sub> = 0~3.6 V  |                           | 1.8     | —                     | ± 5.0                 | μA   |
| 3-State Output Off-State Current |           | I <sub>OZ</sub>  | V <sub>IN</sub> = V <sub>IH</sub> or V <sub>IL</sub><br>V <sub>OUT</sub> = 0~3.6 V |                           | 1.8     | —                     | ± 10.0                | μA   |
| Power Off Leakage Current        |           | I <sub>OFF</sub> | V <sub>IN</sub> , V <sub>OUT</sub> = 0~3.6 V                                       |                           | 0       | —                     | 10.0                  | μA   |
| Quiescent Supply Current         |           | I <sub>CC</sub>  | V <sub>IN</sub> = V <sub>CC</sub> or GND   |                           | 1.8     | —                     | 20.0                  | μA   |
|                                  |           |                  | V <sub>CC</sub> ≤ (V <sub>IN</sub> , V <sub>OUT</sub> ) ≤ 3.6 V                    |                           | 1.8     | —                     | ± 20.0                |      |

AC characteristics (Ta = -40~85°C, Input t<sub>r</sub> = t<sub>f</sub> = 2.0 ns, C<sub>L</sub> = 30 pF, R<sub>L</sub> = 500 Ω)

| PARAMETER                   |  | SYMBOL     | TEST CONDITION |  | VCC (V)   | MIN | MAX | UNIT |
|-----------------------------|--|------------|----------------|--|-----------|-----|-----|------|
|                             |  |            |                |  |           |     |     |      |
| Propagation Delay Time      | t <sub>pLH</sub><br>t <sub>pHL</sub>   | (Fig.1, 2) |                |  | 1.8       | 1.0 | 9.6 | ns   |
|                             |  |            |                |  | 2.5 ± 0.2 | 0.8 | 4.8 |      |
|                             |  |            |                |  | 3.3 ± 0.3 | 0.6 | 3.7 |      |
| 3-State Output Enable Time  | t <sub>pZL</sub><br>t <sub>pZH</sub>   | (Fig.1, 3) |                |  | 1.8       | 1.0 | 9.8 | ns   |
|                             |  |            |                |  | 2.5 ± 0.2 | 0.8 | 5.1 |      |
|                             |  |            |                |  | 3.3 ± 0.3 | 0.6 | 4.1 |      |
| 3-State Output Disable Time | t <sub>pLZ</sub><br>t <sub>pHZ</sub>   | (Fig.1, 3) |                |  | 1.8       | 1.0 | 8.1 | ns   |
|                             |  |            |                |  | 2.5 ± 0.2 | 0.8 | 4.5 |      |
|                             |  |            |                |  | 3.3 ± 0.3 | 0.6 | 4.1 |      |
| Output To Output Skew       | t <sub>osLH</sub><br>t <sub>osHL</sub> | (Note 11)  |                |  | 1.8       | —   | 0.5 | ns   |
|                             |  |            |                |  | 2.5 ± 0.2 | —   | 0.5 |      |
|                             |  |            |                |  | 3.3 ± 0.3 | —   | 0.5 |      |

For C<sub>L</sub> = 50 pF, add approximately 300 ps to the AC maximum specification.

(Note 11) : Parameter guaranteed by design.

$$(t_{osLH} = |t_{pLHm} - t_{pLHn}|, t_{osHL} = |t_{pHLm} - t_{pHLn}|)$$

Dynamic switching characteristics (Ta = 25°C, Input tr = tf = 2.0 ns, CL = 30 pF)

| PARAMETER                        | SYMBOL | TEST CONDITION                   | VCC (V) | TYP.  | UNIT |
|----------------------------------|--------|----------------------------------|---------|-------|------|
|                                  |        |                                  |         |       |      |
| Quiet Output Maximum Dynamic VOL | VOLP   | VIH = 1.8 V, VIL = 0 V (Note 12) | 1.8     | 0.15  | V    |
|                                  |        | VIH = 2.5 V, VIL = 0 V (Note 12) | 2.5     | 0.25  |      |
|                                  |        | VIH = 3.3 V, VIL = 0 V (Note 12) | 3.3     | 0.35  |      |
| Quiet Output Minimum Dynamic VOL | VOLV   | VIH = 1.8 V, VIL = 0 V (Note 12) | 1.8     | -0.15 | V    |
|                                  |        | VIH = 2.5 V, VIL = 0 V (Note 12) | 2.5     | -0.25 |      |
|                                  |        | VIH = 3.3 V, VIL = 0 V (Note 12) | 3.3     | -0.35 |      |
| Quiet Output Minimum Dynamic VOH | VOHV   | VIH = 1.8 V, VIL = 0 V (Note 12) | 1.8     | 1.55  | V    |
|                                  |        | VIH = 2.5 V, VIL = 0 V (Note 12) | 2.5     | 2.05  |      |
|                                  |        | VIH = 3.3 V, VIL = 0 V (Note 12) | 3.3     | 2.65  |      |

(Note 12) : Parameter guaranteed by design.

Capacitive characteristics (Ta = 25°C)

| PARAMETER                     | SYMBOL | TEST CONDITION | VCC (V)                | TYP.          | UNIT |
|-------------------------------|--------|----------------|------------------------|---------------|------|
|                               |        |                |                        |               |      |
| Input Capacitance             | CIN    | —              | 1.8, 2.5, 3.3          | 6             | pF   |
| Output Capacitance            | COU    |                | 1.8, 2.5, 3.3          | 7             | pF   |
| Power Dissipation Capacitance | CPD    |                | fIN = 10 MHz (Note 13) | 1.8, 2.5, 3.3 | 20   |

(Note 13) : CpD is defined as the value of the internal equivalent capacitance which is calculated from the operating current consumption without load.

Average operating current can be obtained by the equation :

$$I_{CC(opr.)} = C_{PD} \cdot V_{CC} \cdot f_{IN} + I_{CC} / 4 \text{ (per bit)}$$

**TEST CIRCUIT**

Fig.1

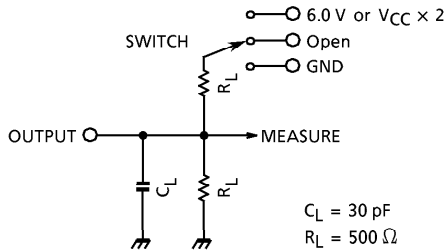

| PARAMETER          | SWITCH   |
|--------------------|--|
| $t_{pLH}, t_{pHL}$ | Open   |
| $t_{pLZ}, t_{pZL}$ | 6.0 V @ $V_{CC} = 3.3 + 0.3 V$<br>$V_{CC} \times 2$ @ $V_{CC} = 2.5 + 0.2 V$<br>@ $V_{CC} = 1.8 V$ |
| $t_{pHZ}, t_{pZH}$ | GND  |

**AC WAVEFORM**

Fig.2  $t_{pLH}, t_{pHL}$

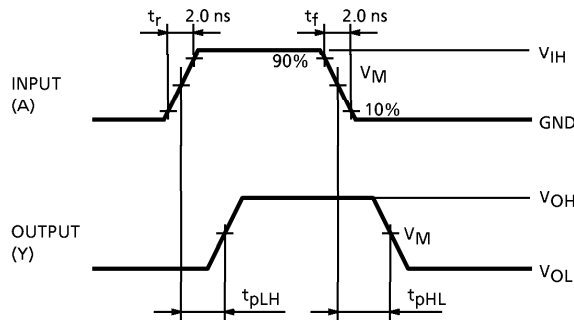
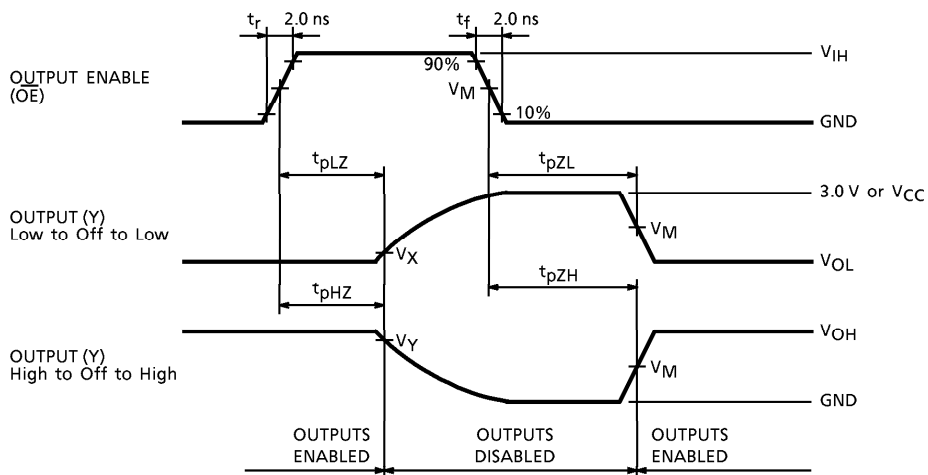

Fig.3  $t_{pLZ}, t_{pHZ}, t_{pZL}, t_{pZH}$



| SYMBOL   | $V_{CC}$         |                   |                   |
|----------|------------------|-------------------|-------------------|
|          | $3.3 \pm 0.3 V$  | $2.5 \pm 0.2 V$   | $1.8 V$           |
| $V_{IH}$ | 2.7V             | $V_{CC}$          | $V_{CC}$          |
| $V_M$    | 1.5V             | $V_{CC}/2$        | $V_{CC}/2$        |
| $V_X$    | $V_{OL} + 0.3 V$ | $V_{OL} + 0.15 V$ | $V_{OL} + 0.15 V$ |
| $V_Y$    | $V_{OH} - 0.3 V$ | $V_{OH} - 0.15 V$ | $V_{OH} - 0.15 V$ |

**PACKAGE DIMENSIONS**  
TSSOP14-P-0044-0.65

Unit : mm

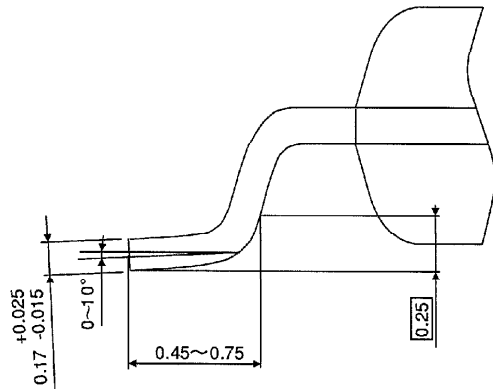
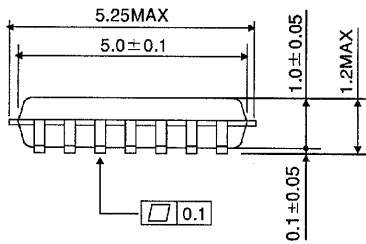
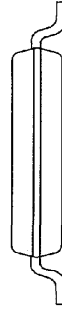
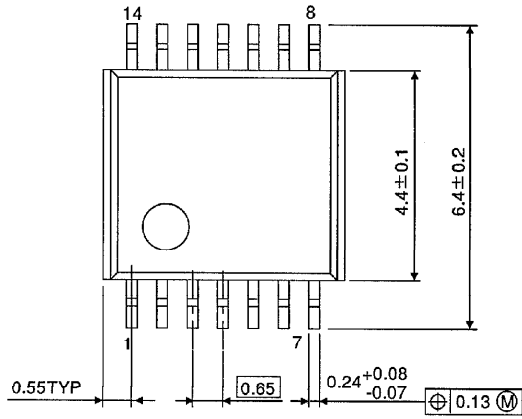

Weight : 0.06 g (Typ.)