

MAXIM

MAX1773 Evaluation Kit

Evaluates: MAX1773

General Description

The MAX1773 evaluation kit (EV kit) is a fully assembled and tested surface-mount circuit board that routes charge and discharge currents between two battery packs, a buck step-down battery charger, and an AC-adaptor power source. The circuit uses a MAX1773 IC in a 20-pin TSSOP package and is configured for an AC-adaptor input range of +4.75VDC to +28VDC.

The EV kit uses seven P-channel MOSFETs to steer current between the power sources and the load. The battery minimum voltage level sets the threshold for battery undervoltage conditions and can be adjusted from +4.65V to +13V.

The EV kit features an SMBus™ signal multiplexer that routes SMBus signals for the smart battery packs. LEDs are provided to indicate the status of the AC adaptor and battery packs. The MAX1773 EV kit also demonstrates low-current usage with several options to reduce current usage.

Features

- ◆ +4.75V to +28V AC-Adapter Input Range
- ◆ Up to 5A Steering Capability
- ◆ P-Channel MOSFET Steering Switches
- ◆ Adjustable Battery Minimum Voltage Level
- ◆ SMBus Multiplexer
- ◆ AC-Present and Battery-Status LEDs
- ◆ Interfaces to MAX1772EVKIT Battery Charger
- ◆ Surface-Mount Components
- ◆ Fully Assembled and Tested

Ordering Information

PART	TEMP. RANGE	IC PACKAGE
MAX1773EVKIT	0°C to +70°C	20 TSSOP

Component List

DESIGNATION	QTY	DESCRIPTION
C1, C6	2	0.1 μ F, 50V X7R ceramic capacitors (0805) Taiyo Yuden UMK212BJ104KG
C2, C3	2	33 μ F, 35V low-ESR tantalum capacitors AVX TPSD336035R0300 or Kemet T495X226K035AS4394 recommended
C4, C5	0	Not installed, 33 μ F, 35V low-ESR capacitors AVX TPSD336035R0300 or Kemet T495X226K035AS4394 recommended
C7	1	4.7 μ F, 6.3V X5R ceramic capacitor (0805) Taiyo Yuden JMK212BJ475KG
C8, C9, C10, C12	4	0.1 μ F, 16V X7R ceramic capacitors (0603) Taiyo Yuden EMK107BJ104MA
C11	1	0.33 μ F, 16V X7R, ceramic capacitor (0805) Taiyo Yuden EMK212BJ334KG

DESIGNATION	QTY	DESCRIPTION
C13, C14	2	1.5 μ F, 25V low-ESR tantalum capacitors AVX TPSA155K025R0300 or Kemet T494A105(1)025AS
D1	1	250mA, 75V switching diode (SOT23) Central Semiconductor CMPD-914
D2, D3	2	Green surface-mount LEDs (SS) Panasonic P521CT
P1–P7	7	8A, -30V P-channel MOSFETs (SuperSOT8) Fairchild FDR858P
R1, R3	2	100k Ω \pm 1% resistors (0805)
R2	1	10k Ω \pm 1% resistor (0805)
R4	1	3.3k Ω \pm 5% resistor (0805)
R5	1	28.7k Ω \pm 1% resistor (0805)
R6	1	100k Ω potentiometer (9mm) Mouser 323-409H-100K
R7	1	40.2k Ω \pm 1% resistor (0805)

SMBus is a trademark of Intel Corp.

MAXIM

Maxim Integrated Products 1

For price, delivery, and to place orders, please contact Maxim Distribution at 1-888-629-4642, or visit Maxim's website at www.maxim-ic.com.

MAX1773 Evaluation Kit

Component List (continued)

DESIGNATION	QTY	DESCRIPTION
R8, R9	2	430Ω ±5% resistors (0805)
R10, R11	2	510kΩ ±5% resistors (0805)
R12, R13, R14	3	8.2kΩ ±5% resistors (0805)
R15–R18	4	10kΩ ±5% resistors (0805)
TB1, TB2	2	5-point terminal blocks (0.2in center) Mouser 506-2MV05
SW1, SW2	2	3-position, SPDT, slide switches Mouser 612-EG1218
JU2, JU3	2	3-pin headers
None	4	Shunts (JU2–JU5)
JU4, JU5	2	2-pin headers
U1	1	MAX1773EUP (20-pin TSSOP)
U2	1	MAX1615EUK (5-pin SOT23)
U3, U4	2	MAX4066CEE (16-pin QSOP)
U5	1	SN74AHC14PWR (14-pin TSSOP)
U6	1	MAX6816EUS-T (4-pin SOT143)
None	1	MAX1773 PC board
None	1	MAX1773 data sheet
None	1	MAX1773 EV kit data sheet

Component Suppliers

SUPPLIER	PHONE	FAX
AVX	803-946-0690	803-626-3123
Central	516-435-1110	516-435-1824
Fairchild	408-822-2000	408-822-2102
Kemet	864-963-6300	864-963-6521
Panasonic	201-392-7522	201-392-4441
Taiyo Yuden	408-573-4150	408-573-4159

Note: Please indicate that you are using the MAX1773 when contacting these component suppliers.

Quick Start

The MAX1773 EV kit is fully assembled and tested. Follow these steps to verify board operation. **Do not turn on the power supply until all connections are completed.**

Power-Up Sequence

Note: See the connection diagram (Figure 1).

- 1) Rotate potentiometer R6 completely clockwise.
- 2) Verify that shunts JU2 (AC_PRESENT), JU3 (BATT_STAT), JU4 (R16, CLK) and JU5 (R17, DAT) are across pins 1 and 2.
- 3) Verify that switches SW1 and SW2 are in position 1 (B battery).
- 4) Connect a +28VDC power supply to the ADAPTER_IN pad. Connect the supply ground to the GND pad next to the ADAPTER_IN pad.
- 5) Connect the EXT_LOAD pad to the battery charger input. Connect the battery charger ground to the GND pad next to the EXT_LOAD pad.
- 6) Connect the battery charger positive output to the CHARGER pad on the EV kit. Connect the battery charger ground to the EV kit GND pad near the CHARGER pad.
- 7) Connect two battery packs or two smart-battery packs (packs with an SBS-IF-compliant connector) to the battery terminals TB1 (A battery) and TB2 (B battery) on the EV kit. Observe the correct polarity during connection. If you are using non-SBS-IF-compliant batteries, add a 10kΩ pull-down resistor on the BATT_A_T and BATT_B_T pins on the battery side of connectors TB1 and TB2.
- 8) Connect a voltmeter to the EXT_LOAD and GND pads.
- 9) Turn on the power supply, and verify that the EXT_LOAD output voltage is approximately +28V.
- 10) Connect a voltmeter to test point 1 (TP1) and ground. Rotate potentiometer R6 to obtain 1.5V at TP1 (battery minimum voltage level = 7.5V).

For instructions on using the SMBUS interface, see the *SMBus Interface* section.

Detailed Description

The MAX1773 EV kit circuit routes charge and discharge currents between two battery packs (regular or smart), a buck step-down battery charger (MAX1772 EV kit recommended), and an AC adapter or DC power source. The circuit uses a MAX1773 in a 20-pin TSSOP package to control seven steering P-channel MOSFET

MAX1773 Evaluation Kit

Evaluates: MAX1773

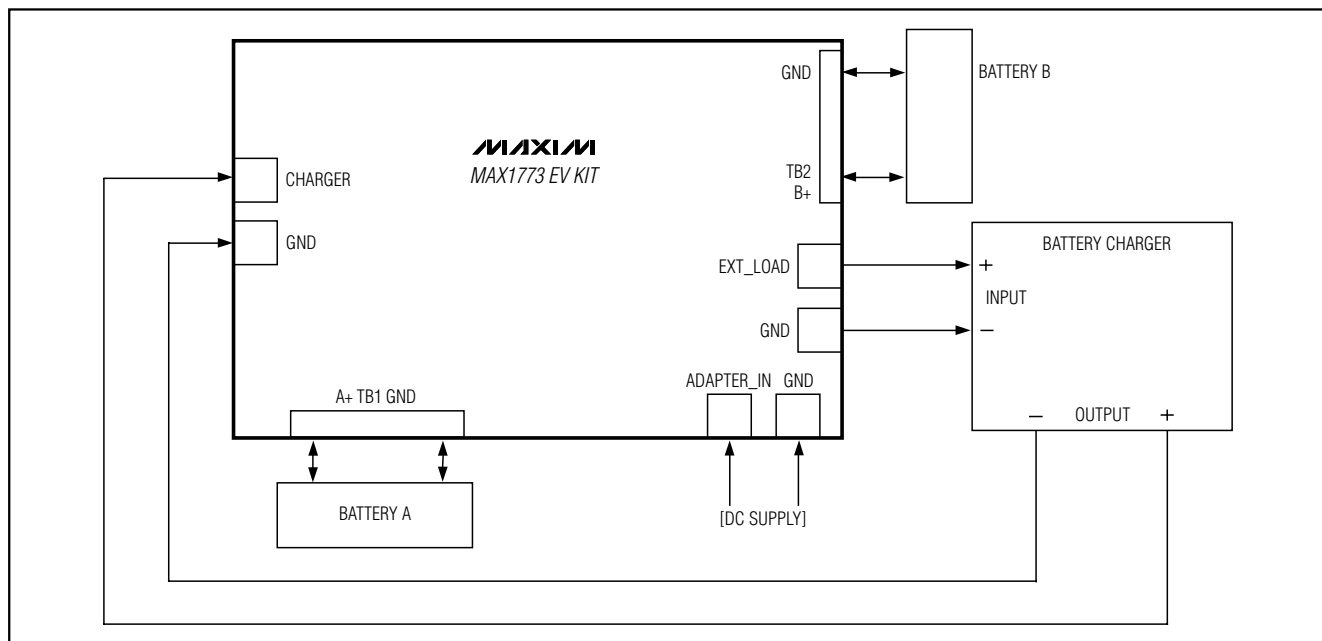

Figure 1. Connection Diagram

switches. A MAX1615 low-power linear regulator provides the circuit board's +3.3V power for logic ICs and status LEDs. The EV kit's AC-adaptor input (ADAPTER_IN) range is from +4.75VDC to +28VDC.

A battery minimum voltage-level potentiometer (R6) allows easy adjustment of the level from +4.65V to +13V. Upon reaching this threshold, an automatic switchover between batteries occurs. See the *Battery Minimum Voltage-Level Adjustment* section for more information on adjusting the level.

The EV kit features an SMBus signal multiplexer for smart battery packs. Two MAX4066 CMOS analog switches and a 74AHC14 inverter are used for multiplexing SMBus signals between both batteries. Manually operated switches (SW1, SW2) are provided to select between battery A or B selection and SMBus multiplexer battery A or B data selection.

LEDs indicate the status of the AC adapter and battery. The LEDs are driven by a pair of inverters and can be disabled by jumpers. Jumpers are provided to disable the CMOS analog switches, CMOS switch debouncer, and inverter ICs for evaluating power usage.

Jumper Selection

Inverter Shutdown Mode

The MAX1773 EV kit features a shutdown mode for the inverters (U5) to reduce the EV kit's overall current. The

2-pin jumper, JU1, selects the shutdown mode for the inverters. Table 1 lists the selectable jumper options.

Table 1. Jumper JU1 Functions

SHORT LOCATION	INVERTER (U5) VCC PIN	INVERTER OUTPUT
1 and 2 (PC trace shorted)	Connected to +3.3V	Inverters powered up
None (PC trace short cut open)	None	Inverters powered down, inverter shutdown mode

AC_PRESENT LED Shutdown

The EV kit features a jumper to enable or disable the AC_PRESENT LEDs. The 3-pin jumper, JU2, selects the mode for the inverters driving the LEDs. Table 2 lists the jumper options.

BATT_STAT LED Shutdown

The MAX1773 EV kit features a jumper to enable or disable the BATT_STAT LEDs. The 3-pin jumper, JU3, selects the mode for the inverters driving the LEDs. Table 3 lists the jumper options.

MAX1773 Evaluation Kit

Table 2. Jumper JU2 Functions

SHUNT LOCATION	INVERTER (U5B) INPUT PIN	LED OPERATING MODE
1 and 2	AC_PRESENT signal feeds inverter	AC_PRESENT LED state driven by MAX1773
2 and 3	AC_PRESENT signal bypassed	AC_PRESENT LED state forced off

Table 3. Jumper JU3 Functions

SHUNT LOCATION	INVERTER (U5E) INPUT PIN	LED OPERATING MODE
1 and 2	BATT_STAT signal feeds inverter	BATT_STAT LED state driven by MAX1773 and inverters
2 and 3	BATT_STAT signal bypassed	BATT_STAT LED state forced off

SMBus Pullup Resistors

The MAX1773 EV kit features pullup resistors for the SMBUS CLK and DAT signals. The CLK and DAT pullup resistors (R16, R17) can be disabled by the 2-pin jumpers JU4 and JU5, respectively. Tables 4 and 5 list the selectable jumper options.

CMOS Analog Switches, Shutdown Mode

The MAX1773 EV kit features a shutdown mode for the CMOS analog switches (MAX4066) to reduce the MAX1773 EV kit's overall current. The 2-pin jumpers, JU6 and JU7, select the shutdown mode for the CMOS analog switches. Tables 6 and 7 list the selectable jumper options.

Table 4. Jumper JU4 Functions

SHUNT LOCATION	R16 RESISTOR	CLK SIGNAL
1 and 2	R16 connected to +3.3V	CLK signal pulled up to +3.3V by R16
None	R16 is floating	Multiplexer controls CLK

Table 5. Jumper JU5 Functions

SHUNT LOCATION	R17 RESISTOR	DAT SIGNAL
1 and 2	R17 connected to +3.3V	DAT signal pulled up to +3.3V by R17
None	R17 is floating	Multiplexer controls CLK

Table 6. Jumper JU6 Functions

SHORT LOCATION	SWITCH (U3) V+ PIN	CMOS ANALOG SWITCHES
1 and 2 (PC trace shorted)	Connected to +3.3V	SMBus CMOS analog switches (U3) powered up
None (PC trace short cut open)	None	SMBus CMOS analog switches (U3) powered down

Table 7. Jumper JU7 Functions

SHORT LOCATION	SWITCH (U4) V+ PIN	CMOS ANALOG SWITCHES
1 and 2 (PC trace shorted)	Connected to +3.3V	SMBus CMOS analog switches (U4) powered up
None (PC trace short cut open)	None	SMBus CMOS analog switches (U4) powered down

CMOS Switch Debouncer, Shutdown Mode

The MAX1773 EV kit features a shutdown mode for the CMOS switch debouncer (MAX6816) to reduce the MAX1773 EV kit's overall current. Two jumpers, JU8 and JU9, select the shutdown mode for the CMOS switch debouncer IC. Tables 8 and 9 list the selectable jumper options.

Switch Selection Modes

Battery Selection Interface

The MAX1773 EV kit features a battery-pack selection interface to select which battery pack is connected to terminals TB1 (battery A) and TB2 (battery B) and may be charged. A three-position switch (SW1) is utilized to select which smart-battery pack will be controlled by the MAX1773 IC.

MAX1773 Evaluation Kit

Evaluates: MAX1773

Table 8. Jumper JU8 Functions

SHORT LOCATION	VCC PIN	CMOS SWITCH DEBOUNCERS
1 and 2 (PC trace shorted)	Connected to +3.3V	CMOS switch debouncer IC (U6) powered up
None (PC trace short cut open)	None	CMOS switch debouncer IC (U6) powered down

Table 9. Jumper JU9 Functions

SHORT LOCATION	OUT PIN	CMOS SWITCH DEBOUNCERS
1 and 2 (PC trace shorted)	Connected to BATT_SEL input	CMOS switch debouncer output
None (PC trace short cut open)	None	CMOS switch debouncer IC (U6) output floating

The switch's center position allows an external controller to select which battery is desired by pulling the BATT_SEL pad high or low. Table 10 lists switch SW1 options.

Caution: Do not connect an external controller to the BATT_SEL pad while switch SW1 is in position 1 or 3 since the external controller may be damaged.

SMBus Interface

The MAX1773 EV kit features an SMBus signal multiplexer for the smart-battery packs connected to terminals (TB1, TB2) and the SMBus interface signals (CLK, DAT, T). A three-position switch (SW2) is utilized to

Table 10. Switch SW1 Functions

SWITCH POSITION	MAX1773 BAT_SEL PIN	BATT_SEL CONTROLS
1	Connected to +3.3V	Battery B selected
2	None, external controller toggles BATT_SEL pad	External controller selects battery A (low) or battery B (high, +3.3V)
3	Connected to GND	Battery A selected

select which smart-battery pack will be connected to the SMBus interface. The switch's center position allows an external controller to select which battery is desired by pulling the COMM pad logic high or low. Table 11 below lists switch SW2 options.

Jumpers JU4 and JU5 allow CLK and DAT to be pulled up to logic high with built-in resistors (R16, R17). See the *SMBus Pullup Resistors* section for jumper selection.

Table 11. Switch SW2 Functions

SWITCH POSITION	INVERTER (U5A) INPUT PIN	COMM CONTROLS
1	Connected to +3.3V	SMBus connected to battery B
2	None, external controller toggles COMM pad	External controller selects battery A (low) or battery B (high, +3.3V) for SMBus
3	Connected to GND	SMBus connected to battery A

Caution: Do not connect an external controller to the COMM pad while switch SW2 is in position 1 or 3 since the external controller may be damaged.

Battery Minimum Voltage Level

Battery Minimum Voltage Level Adjustment

The MAX1773 EV kit features a potentiometer to adjust the battery minimum voltage level. Potentiometer R6 adjusts the battery minimum voltage level from +4.65V to +13V. The battery minimum voltage level is adjusted by the voltage at test point TP1. The battery minimum voltage level is equal to the voltage at TP1 multiplied by 5 ($V_{TP1} \times 5$; i.e., +7.5V level = 1.5V x 5). Rotate R6 counterclockwise to decrease the battery minimum voltage level or clockwise to increase it.

Using the MAX1772 EV Kit Charger with the MAX1773 EV Kit

MAX1772 EV Kit Charger Connections

The MAX1773 EV kit can be used with the MAX1772 EV kit charger. For correct connection between the two EV kits, jumper JU4 must be cut open on the MAX1772 EV kit. Refer to the MAX1772 EV kit data sheet for additional information on jumper JU4. Figure 2 shows how to connect the MAX1772 EV kit to a MAX1773 EV kit, AC adapter, two batteries, and a load.

MAX1773 Evaluation Kit

Evaluates: MAX1773

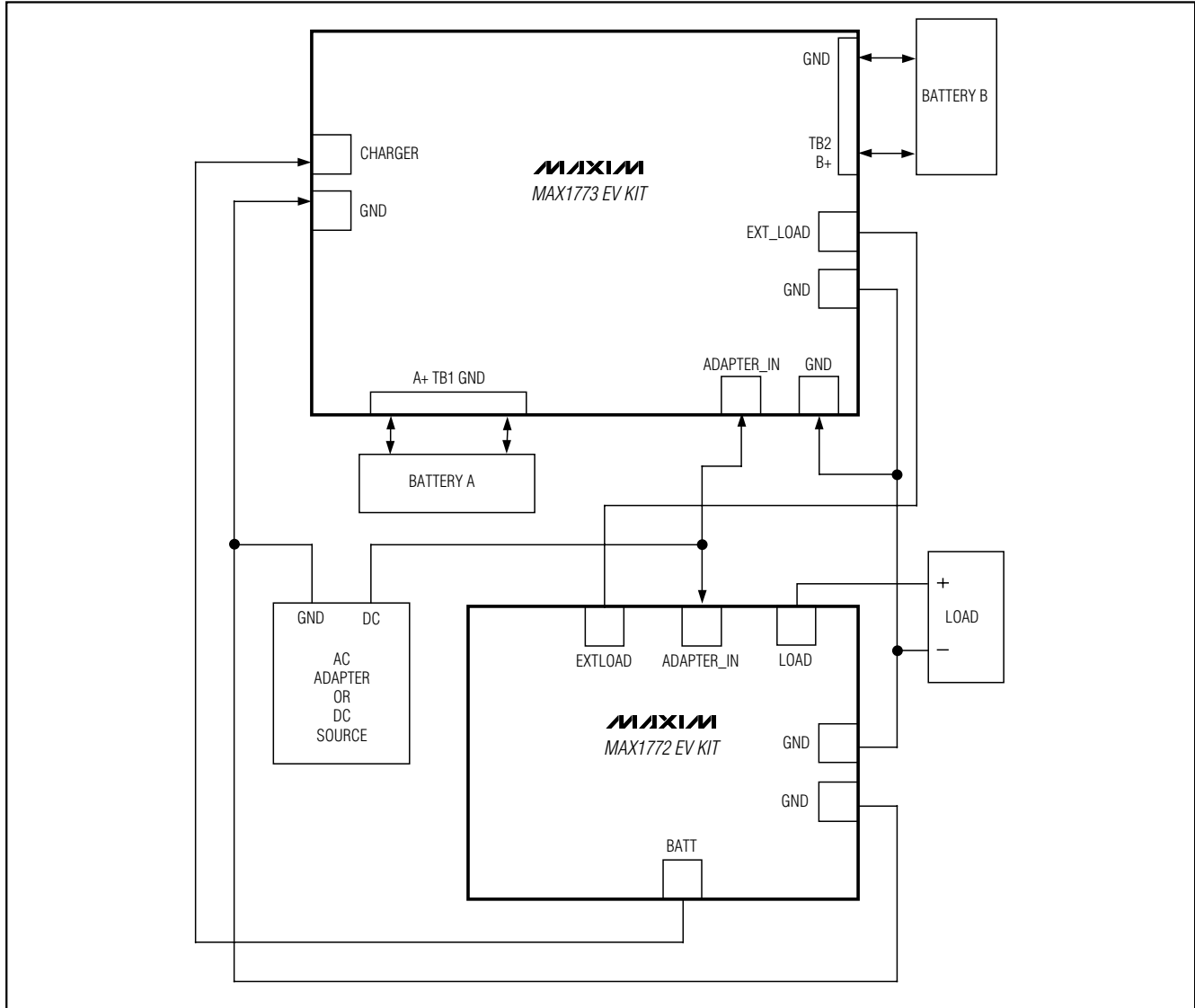

Figure 2. MAX1772 EV Kit Charger to MAX1773 EV Kit Connection Diagram

MAX1773 Evaluation Kit

Evaluates: MAX1773

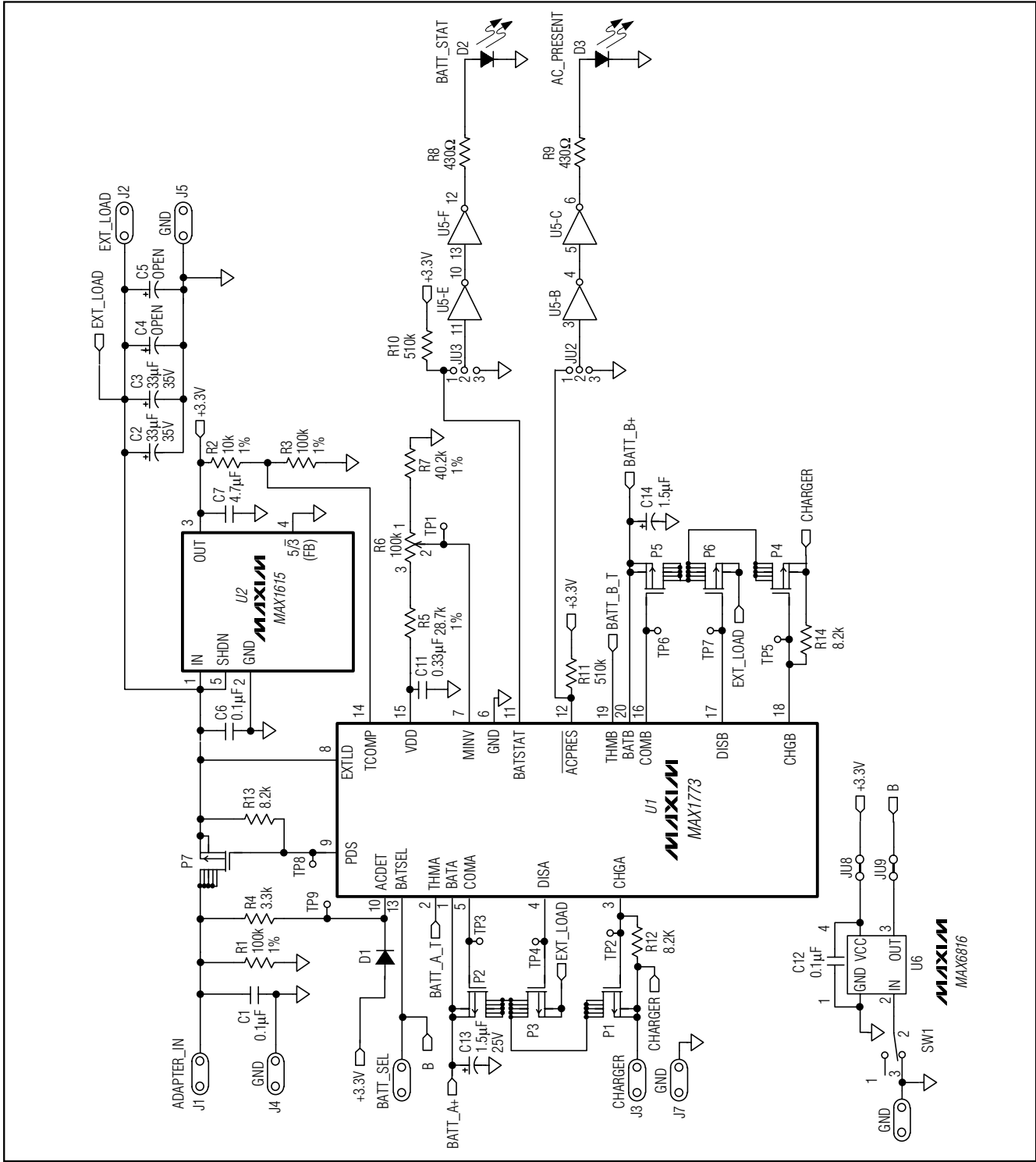

Figure 3. MAX1773 EV Kit Schematic

MAX1773 Evaluation Kit

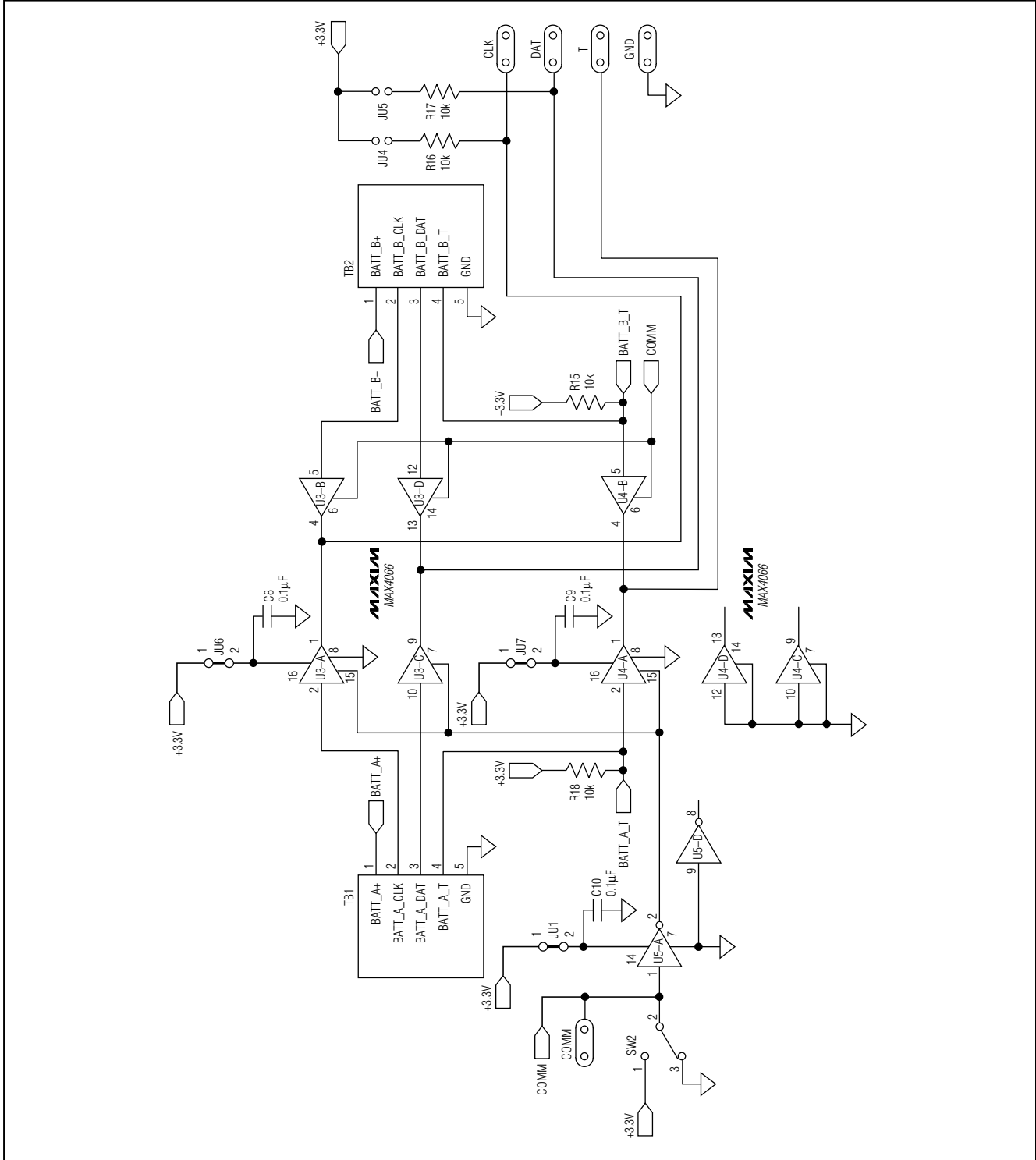

Figure 4. MAX1773 EV Kit Schematic, SMBus Signal Multiplexers

MAX1773 Evaluation Kit

Evaluates: MAX1773

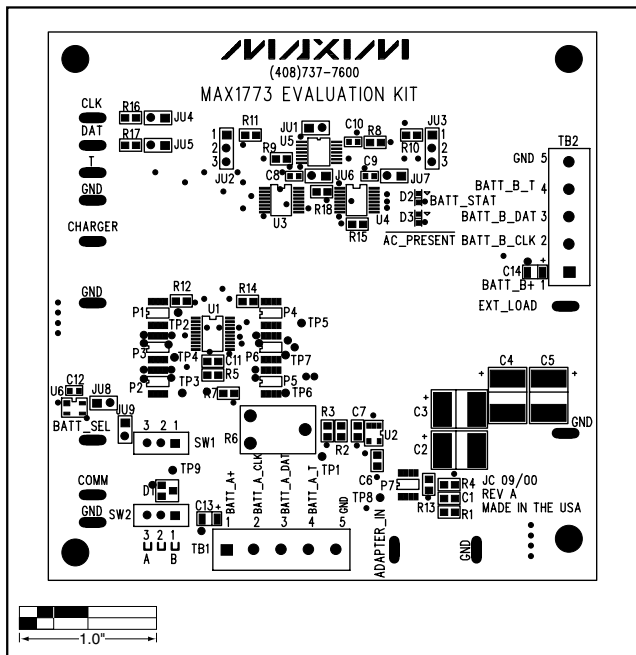

Figure 5. MAX1773 EV Kit Component Placement Guide—Component Side

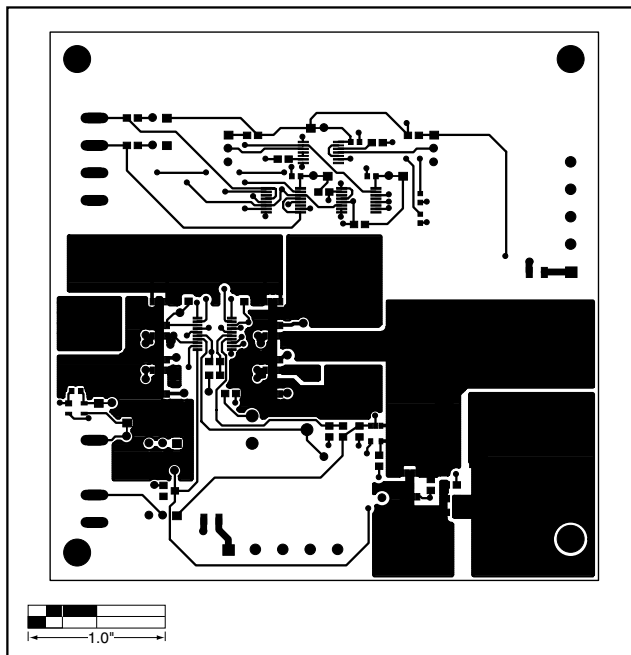

Figure 6. MAX1773 EV Kit PC Board Layout—Component Side

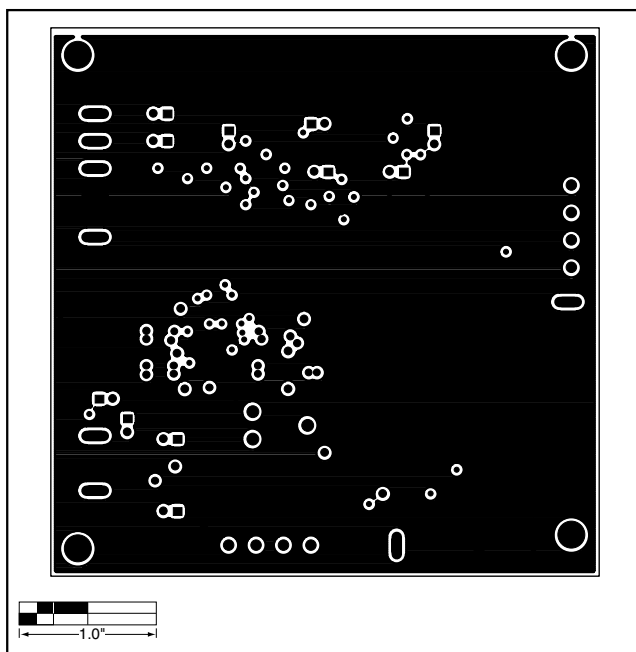

Figure 7. MAX1773 EV Kit PC Board Layout—Inner Layer 2



Figure 8. MAX1773 EV Kit PC Board Layout—Inner Layer 3

MAX1773 Evaluation Kit

Evaluates: MAX1773

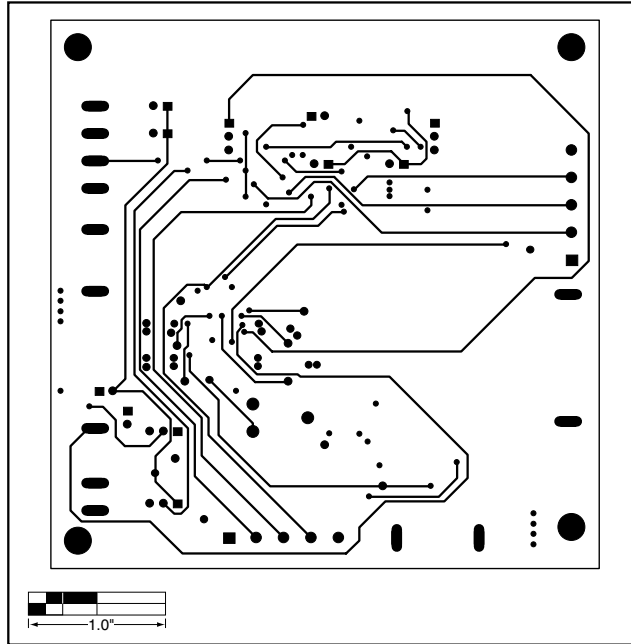

Figure 9. MAX1773 EV Kit PC Board Layout—Solder Side

Maxim cannot assume responsibility for use of any circuitry other than circuitry entirely embodied in a Maxim product. No circuit patent licenses are implied. Maxim reserves the right to change the circuitry and specifications without notice at any time.

10 **Maxim Integrated Products, 120 San Gabriel Drive, Sunnyvale, CA 94086 408-737-7600**