

0.5 dB LSB GaAs MMIC 5-BIT DIGITAL ATTENUATOR, 0.7 - 3.8 GHz

Typical Applications

The HMC306MS10 is ideal for:

- Cellular, PCS, & 3G
- ISM, MMDS
- Wireless Local Loop

Functional Diagram

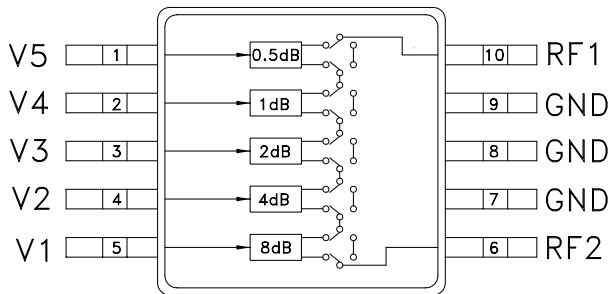

Features

- 0.5 dB LSB Steps to 15.5 dB
- Single Positive Control Per Bit
- ± 0.3 dB Typical Bit Error
- Miniature 15 mm² Package: MSOP10

General Description

The HMC306MS10 is a broadband 5-bit positive control GaAs IC digital attenuator in a 10 lead MSOP surface mount plastic package. Covering 0.7 to 3.8 GHz, the insertion loss is typically less than 1.5 to 2.3 dB. The attenuator bit values are 0.5 (LSB), 1, 2, 4 and 8 dB for a total attenuation of 15.5 dB. Attenuation accuracy is excellent at ± 0.25 dB typical with an IIP3 of up to +52 dBm. Five bit control voltage inputs, toggled between 0 and +3 to +5V, are used to select each attenuation state at less than 50 uA each. A single Vdd bias of +3 to +5V applied through an external 5K Ohm resistor is required. The HMC306MS10 occupies less than 14.8 mm².

Electrical Specifications,

$T_A = +25^\circ C$, $V_{dd} = +3V$ to $+5V$ & $V_{CTL} = 0/V_{dd}$ (Unless Otherwise Stated)

Parameter	Frequency (GHz)	Min.	Typical	Max.	Units
Insertion Loss	0.7 - 1.4		1.3	1.6	dB
	1.4 - 2.3		1.5	2.0	dB
	2.3 - 2.7		1.8	2.5	dB
	2.7 - 3.8		2.3	2.7	dB
Attenuation Range			15.5		dB
Return Loss (RF1 & RF2, All Atten. States)	0.7 - 1.4	15	21		dB
	1.4 - 2.3	14	18		dB
	2.3 - 2.7	13	16		dB
	2.7 - 3.8	10	13		dB
Attenuation Accuracy: (Referenced to Insertion Loss)	All Attenuation States	0.7 - 1.4	± 0.30 + 5% of Atten. Setting Max.		dB
	All Attenuation States	1.4 - 2.3	± 0.25 + 3% of Atten. Setting Max.		dB
	All Attenuation States	2.3 - 2.7	± 0.30 + 4% of Atten. Setting Max.		dB
	0.5 - 13.0 dB States	2.7 - 3.8	± 0.40 + 4% of Atten. Setting Max.		dB
	13.5 - 15.5 dB States	2.7 - 3.8	± 0.50 + 5% of Atten. Setting Max.		dB
Input Power for 0.1 dB Compression	V _{dd} = 5V V _{dd} = 3V	0.7 - 3.8	25		dBm
			23		dBm
Input Third Order Intercept Point (Two-tone Input Power = 0 dBm Each Tone)	V _{dd} = 5V V _{dd} = 3V	0.7 - 3.8	52		dBm
			48		dBm
Switching Characteristics	0.7 - 3.8	t _{RISE} , t _{FALL} (10/90% RF)	560		ns
		t _{ON} , t _{OFF} (50% CTL to 10/90% RF)	600		ns

0.5 dB LSB GaAs MMIC 5-BIT DIGITAL ATTENUATOR, 0.7 - 3.8 GHz

Insertion Loss

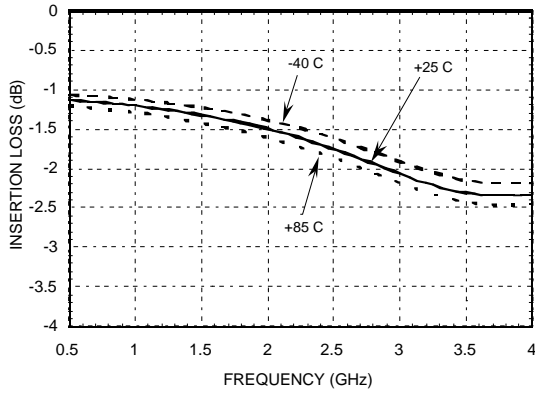

Return Loss RF1, RF2 (Only Major States are Shown)

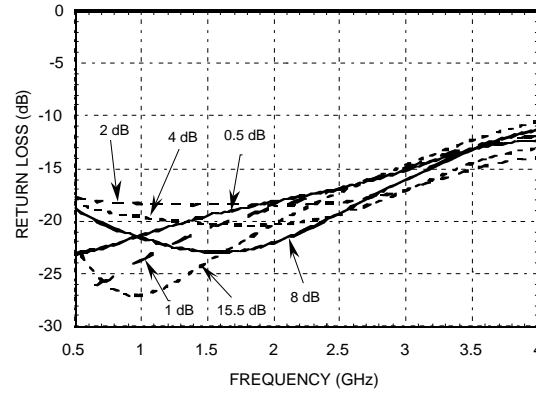

Normalized Attenuation (Only Major States are Shown)

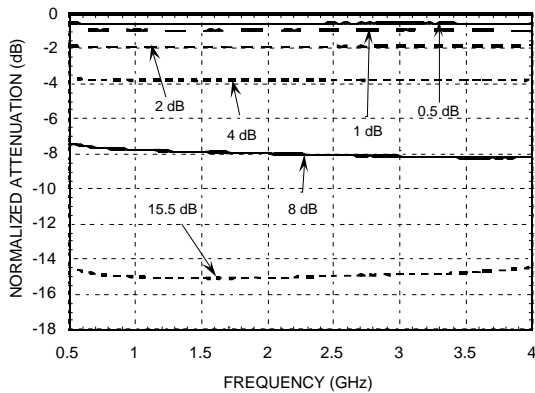

Absolute Bit Error vs. Attenuation State

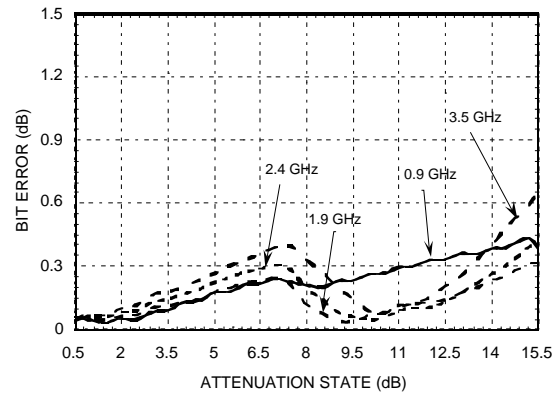

Absolute Bit Error vs. Frequency (Only Major States are Shown)

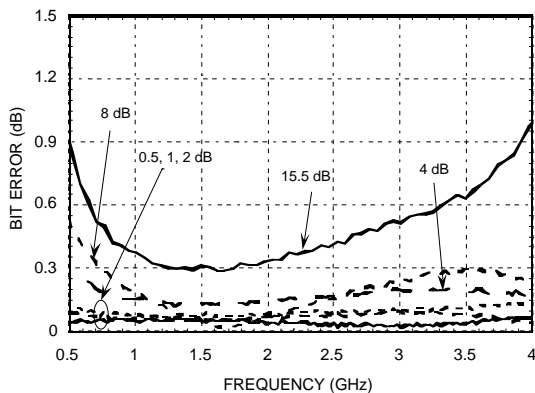

Relative Phase vs. Frequency (Only Major States are Shown)

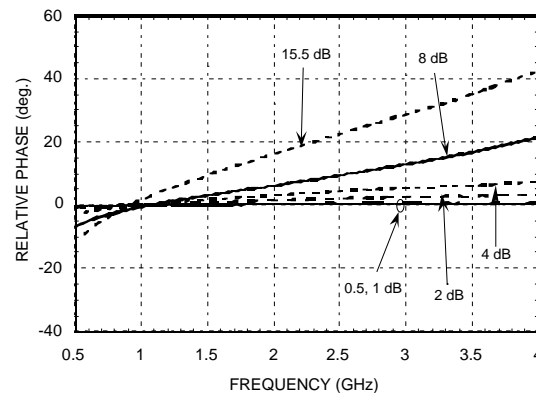

0.5 dB LSB GaAs MMIC 5-BIT DIGITAL ATTENUATOR, 0.7 - 3.8 GHz

Truth Table

Control Voltage Input					Attenuation State RF1 - RF2
V1 8 dB	V2 4 dB	V3 2 dB	V4 1 dB	V5 0.5 dB	
High	High	High	High	High	Reference I.L.
High	High	High	High	Low	0.5 dB
High	High	High	Low	High	1 dB
High	High	Low	High	High	2 dB
High	Low	High	High	High	4 dB
Low	High	High	High	High	8 dB
Low	Low	Low	Low	Low	15.5 dB Max. Atten.

Any combination of the above states will provide an attenuation approximately equal to the sum of the bits selected.

Control & Bias Voltages

State	Bias Condition
Low	0 to +0.2V @ 20 μ A Max.
High	Vdd \pm 0.2V @ 20 μ A Max.

Note: Vdd = +3V to 5V \pm 0.2V

Application Circuit

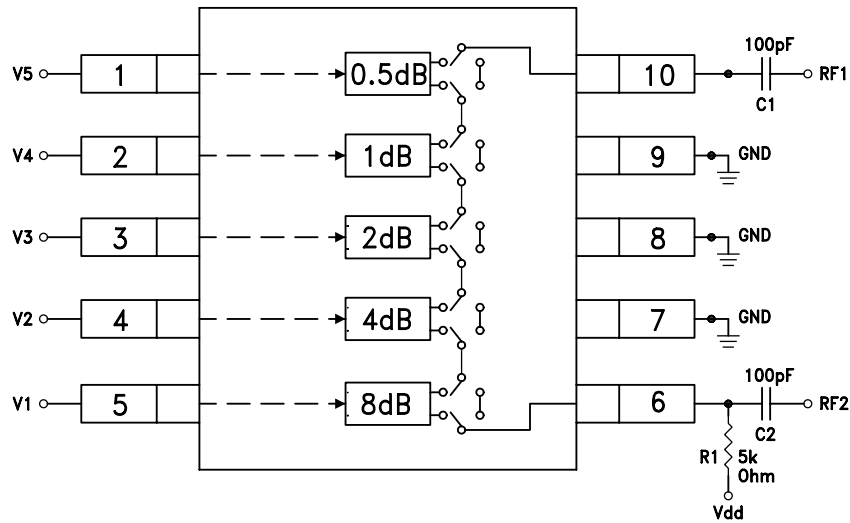

Note:

DC Blocking Capacitors C1 & C2 are required on RF1 & RF2. Choose C1 = C2 = 100 ~ 300 pF to allow lowest customer specific frequency to pass with minimal loss. R1= 5K Ohm is required to supply voltage to the circuit through either Pin 6 or Pin 10.

0.5 dB LSB GaAs MMIC 5-BIT DIGITAL ATTENUATOR, 0.7 - 3.8 GHz

Absolute Maximum Ratings

Control Voltage (V1 - V5)	Vdd + 0.5 Vdc
Bias Voltage (Vdd)	+8.0 Vdc
Storage Temperature	-65 to +150 °C
Operating Temperature	-40 to +85 °C
RF Input Power (0.7 - 3.8 GHz)	+28 dBm

Outline Drawing

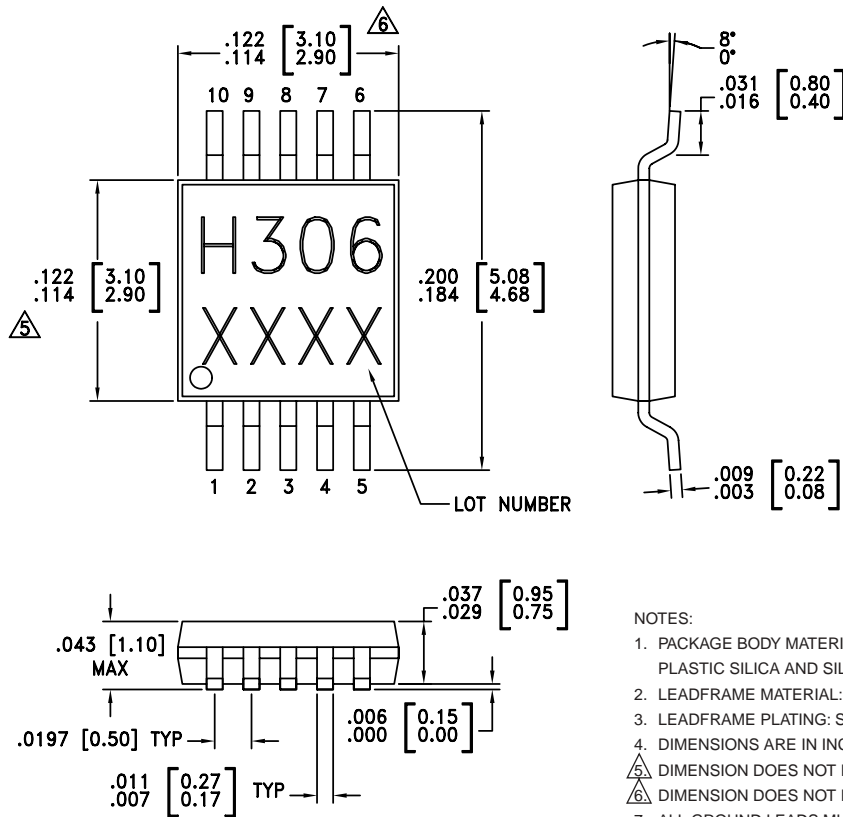

- NOTES:
1. PACKAGE BODY MATERIAL: LOW STRESS INJECTION MOLDED PLASTIC SILICA AND SILICON IMPREGNATED.
 2. LEADFRAME MATERIAL: COPPER ALLOY
 3. LEADFRAME PLATING: Sn/Pb SOLDER
 4. DIMENSIONS ARE IN INCHES [MILLIMETERS].
 5. DIMENSION DOES NOT INCLUDE MOLDFLASH OF 0.15mm PER SIDE.
 6. DIMENSION DOES NOT INCLUDE MOLDFLASH OF 0.25mm PER SIDE.
 7. ALL GROUND LEADS MUST BE SOLDERED TO PCB RF GROUND.

0.5 dB LSB GaAs MMIC 5-BIT DIGITAL ATTENUATOR, 0.7 - 3.8 GHz

Evaluation Circuit Board

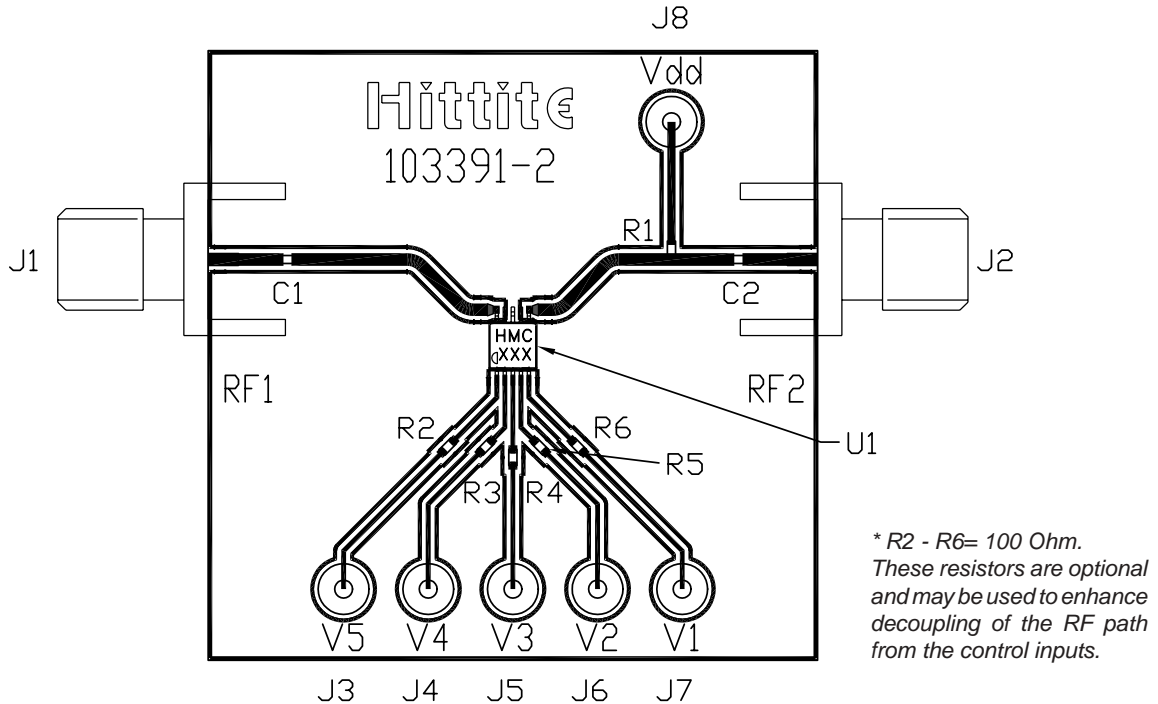

The circuit board used in the final application should use RF circuit design techniques. Signal lines should have 50 ohm impedance while the package ground leads should be connected directly to the ground plane similar to that shown. A sufficient number of via holes should be used to connect the top and bottom ground planes. The evaluation circuit board shown is available from Hittite upon request.

List of Material

Item	Description
J1 - J2	PC Mount SMA Connector
J3 - J8	DC Pin
R1	5k Ohm Resistor, 0402 Pkg.,
R2 - R6	100 Ohm Resistor, 0402 Pkg.
C1 - C2	0402 Chip Capacitor, Select Value for Lowerst Frequency
U1	HMC306MS10 Digital Attenuator
PCB*	103391 Evaluation PCB 1.5" x 1.5"
*Circuit Board Material: Rogers 4350	



v03.0403

HMC306MS10

0.5 dB LSB GaAs MMIC 5-BIT DIGITAL ATTENUATOR, 0.7 - 3.8 GHz

Notes: