

FSAB20PH60

Smart Power Module for Partial Switching Converter

Features

- Very low thermal resistance due to using DBC
- 600V-20A single-phase rectifier bridge diode including two IGBTs for partial switching converter
- Integrated IC for gate driving and protection
- Divided negative dc-link terminals for current sensing
- Isolation rating of 2500Vrms/min.

Applications

- AC 187V ~ 276V single-phase partial-switching converter of air-conditioner

General Description

FSAB20PH60 is an advanced smart power module of PSC(Partial Switching Converter) that Fairchild has newly developed and designed mainly targeting low-power application especially for an air conditioners. It combines optimized circuit protection and drive IC matched to IGBTs. System reliability is further enhanced by the integrated under-voltage lock-out and short-circuit protection function.

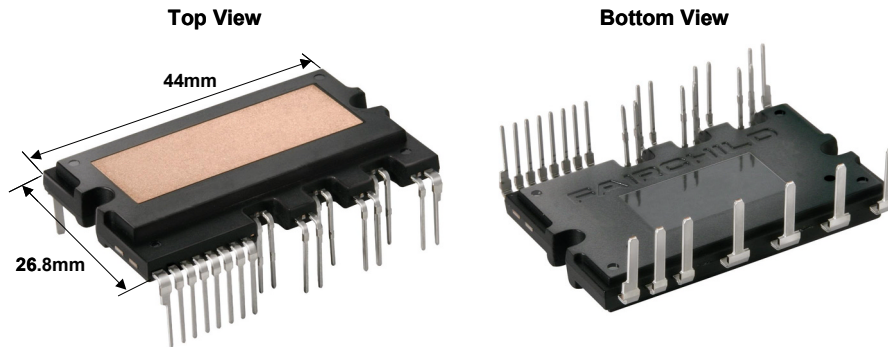

Figure 1.

Integrated Power Functions

- 600V-20A rectifiers for single-phase ac input with IGBT switches for operation of partial switching converter

Integrated Drive, Protection and System Control Functions

- For IGBTs: Gate drive circuit, Short circuit protection (SC)
Control supply circuit under-voltage (UV) protection
- Fault signaling: Corresponding to a UV fault (Low-side supply)
- Input interface: 5V CMOS/LSTTL compatible, Schmitt trigger input
- Built-in thermistor: Over-temperature monitoring

Pin Configuration

Top View

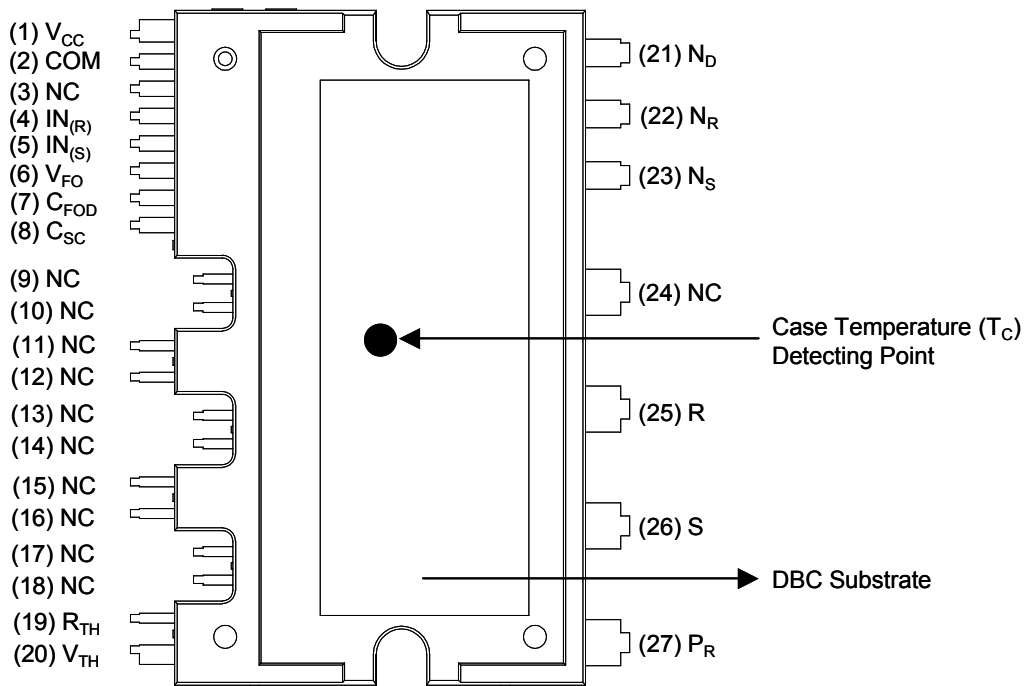
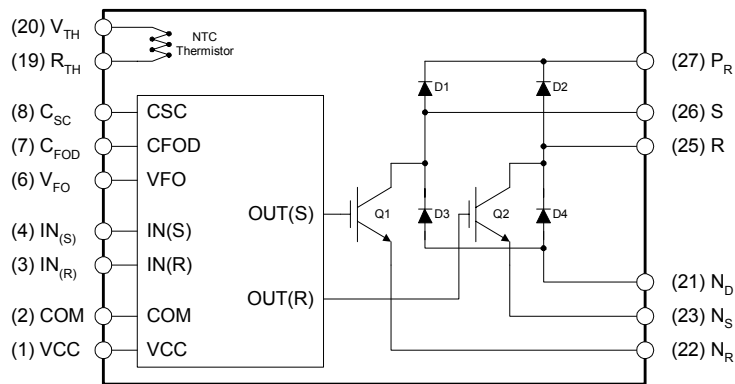

Figure 2.

Pin Descriptions

Pin Number	Pin Name	Pin Description
1	V _{CC}	Common Bias Voltage for IC
2	COM	Common Supply Ground
3	NC	Dummy Pin
4	IN _(R)	Signal Input for R-phase IGBT
5	IN _(S)	Signal Input for S-phase IGBT
6	V _{FO}	Fault Output
7	C _{FOD}	Capacitor for Fault Output Duration Time Selection
8	C _{SC}	Capacitor (Low-pass Filter) for Short-Current Detection
9	NC	Dummy Pin
10	NC	Dummy Pin
11	NC	Dummy Pin
12	NC	Dummy Pin
13	NC	Dummy Pin
14	NC	Dummy Pin
15	NC	Dummy Pin
16	NC	Dummy Pin
17	NC	Dummy Pin
18	NC	Dummy Pin
19	R _(TH)	Series Resistor for the Use of Thermistor (Temperature Detection)
20	V _(TH)	Thermistor Bias Voltage
21	N _D	Negative DC-Link of Rectifier Diode
22	N _R	Negative DC-Link of R-phase IGBT
23	N _S	Negative DC-Link of S-phase IGBT
24	NC	Dummy Pin
25	R	AC Input for R Phase
26	S	AC Input for S Phase
27	P _R	Positive DC-Link Output

Internal Equivalent Circuit and Input/Output Pins



Note:

The low-side is composed of two IGBTs including rectifying diodes for each IGBT and one control IC which has gate driving, current sensing and protection functions. The high-side is composed of two rectifying diodes without gate driving IC.

Figure 3.

Absolute Maximum Ratings ($T_J = 25^\circ\text{C}$, Unless Otherwise Specified)

Converter Part

Symbol	Parameter	Conditions	Rating	Units
V_i	Input Supply Voltage	Applied between R-S	276	V
$V_{i(\text{Surge})}$	Input Supply Voltage (Surge)	Applied between R-S	500	V
V_{PN}	Output Voltage	Applied between P-N	400	V
$V_{PN(\text{surge})}$	Output Voltage (Surge)	Applied between P-N	500	V
V_{CES}	Collector-emitter Voltage	IGBT	600	V
V_{RRM}	Repetitive Peak Reverse Voltage	Diode	600	V
I_i	Input Current (100% Load)	$T_C \leq 90^\circ\text{C}$, $V_O = 280\text{V}$, $f_{PWM} = 60\text{Hz}$	11	A_{RMS}
I_i	Input Current (130% Load)	$T_C \leq 90^\circ\text{C}$, $V_O = 280\text{V}$, $f_{PWM} = 60\text{Hz}$	14	A_{RMS}
T_J	Operating Junction Temperature	(Note 1)	-20 ~ 125	$^\circ\text{C}$

Note:

1. The maximum junction temperature rating of the power chips integrated within the module is 150°C ($@T_C \leq 100^\circ\text{C}$). However, to insure safe operation, the average junction temperature should be limited to $T_{J(\text{ave})} \leq 125^\circ\text{C}$ ($@T_C \leq 100^\circ\text{C}$)

Control Part

Symbol	Parameter	Conditions	Rating	Units
V_{CC}	Control Supply Voltage	Applied between V_{CC} - COM	20	V
V_{IN}	Input Signal Voltage	Applied between $IN_{(R)}$, $IN_{(S)}$ - COM	$-0.3 \sim V_{CC} + 0.3$	V
V_{FO}	Fault Output Supply Voltage	Applied between V_{FO} - COM	$-0.3 \sim V_{CC} + 0.3$	V
I_{FO}	Fault Output Current	Sink Current at V_{FO} Pin	5	mA
V_{SC}	Current Sensing Input Voltage	Applied between C_{SC} - COM	$-0.3 \sim V_{CC} + 0.3$	V

Total System

Symbol	Parameter	Conditions	Rating	Units
T_C	Module Case Operation Temperature	$-20^\circ\text{C} < T_J < 125^\circ\text{C}$, See Fig.2	-20 ~ 100	$^\circ\text{C}$
T_{STG}	Storage Temperature		-40 ~ 125	$^\circ\text{C}$
V_{ISO}	Isolation Voltage	60Hz, Sinusoidal, AC 1 minute, Connection Pins to DBC	2500	V_{rms}

Absolute Maximum Ratings

Thermal Resistance

Symbol	Parameter	Conditions	Min.	Typ.	Max.	Units
$R_{th(j-c)Q}$	Junction to Case Thermal Resistance	Each IGBT under Operating Condition	-	-	2.8	$^{\circ}C/W$
$R_{th(j-c)D}$		Each Diode under Operating Condition	-	-	2.6	$^{\circ}C/W$

Note:

2. For the measurement point of case temperature(T_C), please refer to Figure 2.

Electrical Characteristics ($T_J = 25^{\circ}C$, Unless Otherwise Specified)

Main Circuit Part

Symbol	Item	Conditions	Min.	Typ.	Max.	Units
$V_{CE(SAT)}$	Collector-Emitter Saturation Voltage	$V_{CC} = V_{BS} = 15V$ $V_{IN} = 5V$ $I_C = 6.5A, T_J = 25^{\circ}C$	-	2.1	2.6	V
V_{FM}	Diode Forward Voltage	$V_{IN} = 0V$ $I_C = 20A, T_J = 25^{\circ}C$	-	1.1	1.5	V
t_{ON}	Switching Times	$V_{PN} = 300V, V_{CC} = V_{BS} = 15V$ $I_C = 6.5A$ $V_{IN} = 0V \leftrightarrow 5V$, Inductive Load (Note 3)	-	0.48	-	μs
$t_{C(ON)}$			-	0.85	-	μs
t_{OFF}			-	0.56	-	μs
$t_{C(OFF)}$			-	0.10	-	μs
t_{rr}			-	1.35	-	μs
I_{CES}	Collector - Emitter Leakage Current	$V_{CE} = V_{CES}$	-	-	250	μA
I_R	Diode Leakage Current	$V_R = V_{RRM}$	-	-	250	μA

Note:

3. t_{ON} and t_{OFF} include the propagation delay time of the internal drive IC. $t_{C(ON)}$ and $t_{C(OFF)}$ are the switching time of IGBT itself under the given gate driving condition internally. For the detailed information, please see Figure 4.

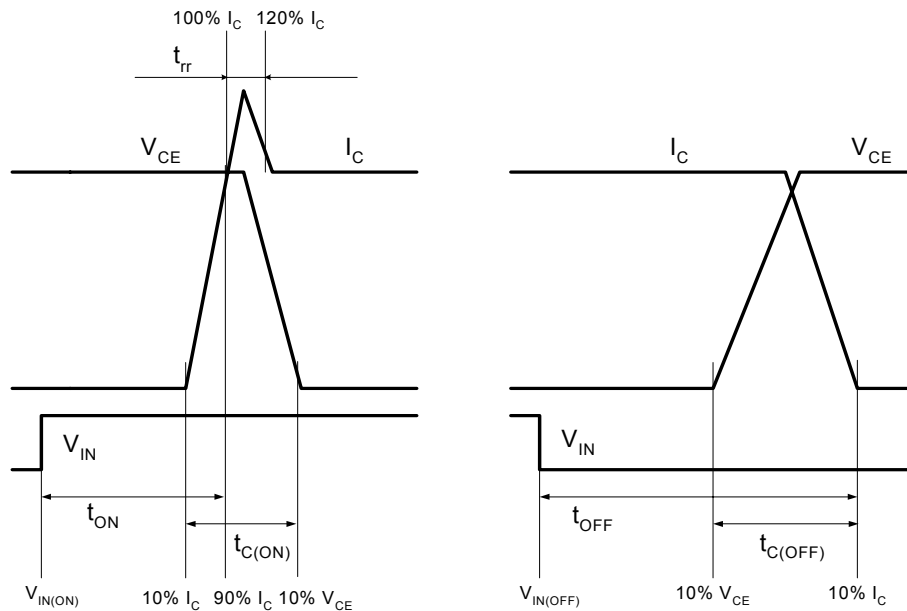

Figure 4. Switching Time Definition

Electrical Characteristics (T_J = 25°C, Unless Otherwise Specified)

Control Part

Symbol	Parameter	Conditions	Min.	Typ.	Max.	Units
I _{QCCL}	Quiescent V _{CC} Supply Current	V _{CC} = 15V I _{N(L)} = 0V	-	-	23	mA
V _{FOH}	Fault Output Voltage	V _{SC} = 0V, V _{FO} Circuit: 4.7kΩ to 5V Pull-up	4.5	-	-	V
V _{FOL}		V _{SC} = 1V, V _{FO} Circuit: 4.7kΩ to 5V Pull-up	-	-	0.8	V
V _{SC(ref)}	Short Circuit Trip Level	V _{CC} = 15V (Note 4)	0.45	0.5	0.55	V
UV _{CCD}	Supply Circuit Under-Voltage Protection	Detection Level	10.7	11.9	13.0	V
UV _{CCR}		Reset Level	11.2	12.4	13.2	V
t _{FOD}	Fault-out Pulse Width	C _{FOD} = 33nF (Note 5)	1.0	1.8	-	ms
V _{IN(ON)}	ON Threshold Voltage	Applied between I _{N(R)} , I _{N(S)} - COM	3.0	-	-	V
V _{IN(OFF)}	OFF Threshold Voltage		-	-	0.8	V
R _{TH}	Resistance of Thermistor	@ T _C = 25°C (Note Fig. 10)	-	50	-	kΩ
		@ T _C = 80°C (Note Fig. 10)	-	5.76	-	kΩ

Note:

4. Over current protection is functioning only for the low-side IGBT.

5. The fault-out pulse width t_{FOD} depends on the capacitance value of C_{FOD} according to the following approximate equation : C_{FOD} = 18.3 x 10⁻⁶ x t_{FOD}[F]

Recommended Operating Conditions

Symbol	Parameter	Condition	Value			Units
			Min.	Typ.	Max.	
V _i	Input Supply Voltage	Applied between R - S	187	-	276	V _{rms}
V _{PN}	Output Voltage	Applied between P - N	-	280	400	V
V _{CC}	Control Supply Voltage	Applied between V _{CC} - COM	13.5	15	16.5	V
f _{PWM}	PWM Input Signal	T _C ≤ 100°C, T _J ≤ 125°C, Per IGBT (Note 6)	-	60	-	Hz

Note:

6. Regarding the switching method of FSAB20PH60, it follows the control method of the typical partial-switching power factor correction circuit as shown in Figure 5.

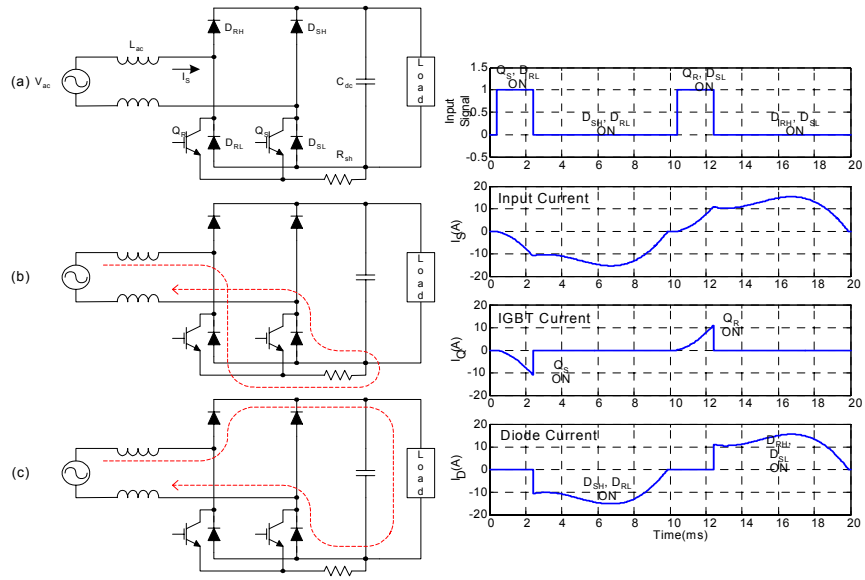

Note:

Q_R or Q_S depending on the polarity of input voltage V_{ac} , is turned on at the zero crossing point of input voltage, and turned off considering the output power and distortion of input current. Each IGBT turns on with zero current with the utility frequency, 50 or 60Hz.

Figure 5. PWM Example of FSAB20PH60

Mechanical Characteristics and Ratings

Parameter	Conditions		Limits			Units
			Min.	Typ.	Max.	
Mounting Torque	Mounting Screw: M3	Recommended 0.62Nm	0.51	0.62	0.72	N·m
Heatsink Flatness		Note Fig. 6	0	-	120	μm
Weight			-	15.00	-	g

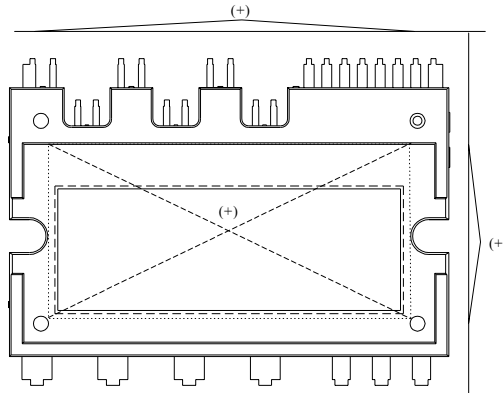
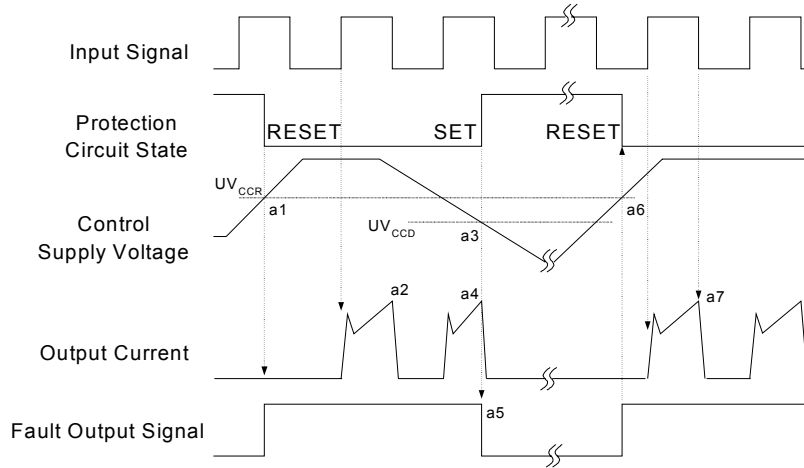

Figure 6. Flatness Measurement Position

Time Charts of SPMs Protective Function



- a1 : Control supply voltage rises: After the voltage rises UV_{CCR} , the circuits start to operate when next input is applied.
- a2 : Normal operation: IGBT ON and carrying current.
- a3 : Under voltage detection (UV_{CCD}).
- a4 : IGBT OFF in spite of control input condition.
- a5 : Fault output operation starts.
- a6 : Under voltage reset (UV_{CCR}).
- a7 : Normal operation: IGBT ON and carrying current.

Figure 7. Under-Voltage Protection

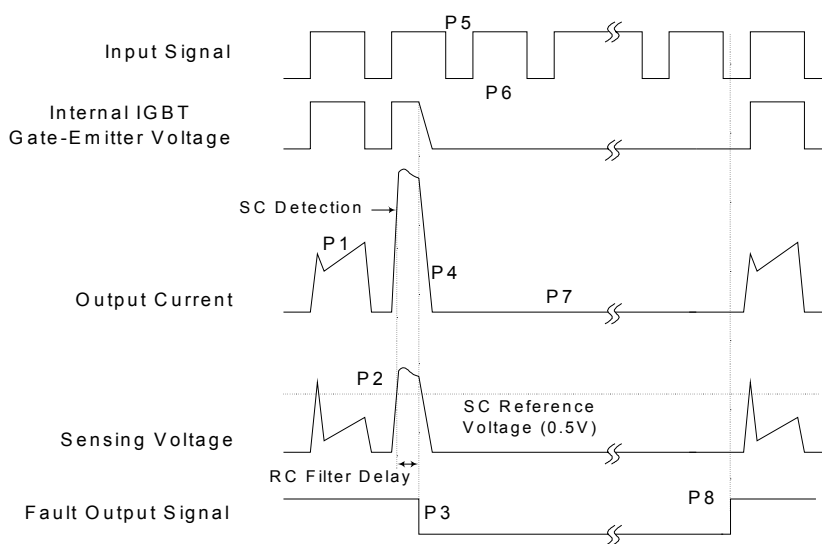

(with the external shunt resistance and CR connection)

- c1 : Normal operation: IGBT ON and carrying current.
- c2 : Short circuit current detection (SC trigger).
- c3 : Hard IGBT gate interrupt.
- c4 : IGBT turns OFF.
- c5 : Fault output timer operation starts: The pulse width of the fault output signal is set by the external capacitor C_{FO} .
- c6 : Input "L" : IGBT OFF state.
- c7 : Input "H": IGBT ON state, but during the active period of fault output the IGBT doesn't turn ON.
- c8 : IGBT OFF state

Figure 8. Over Current Protection

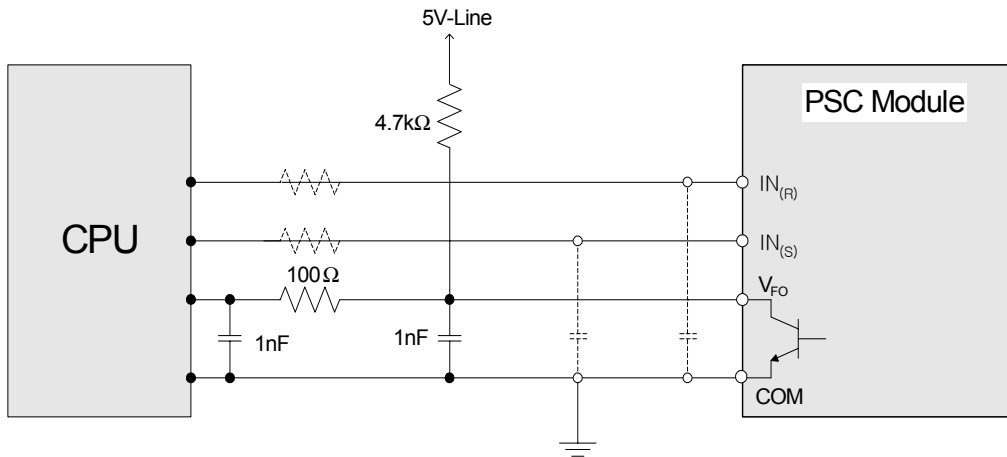

Note:

1. RC coupling at each input (parts shown dotted) might change depending on the PWM control scheme used in the application and the wiring impedance of the application's printed circuit board. The SPM input signal section integrates 3.3kΩ (typ.) pull-down resistor. Therefore, when using an external filtering resistor, please pay attention to the signal voltage drop at input terminal.
2. The logic input is compatible with standard CMOS or LSTTL outputs.

Figure 9. Recommended CPU I/O Interface Circuit

R-T Graph

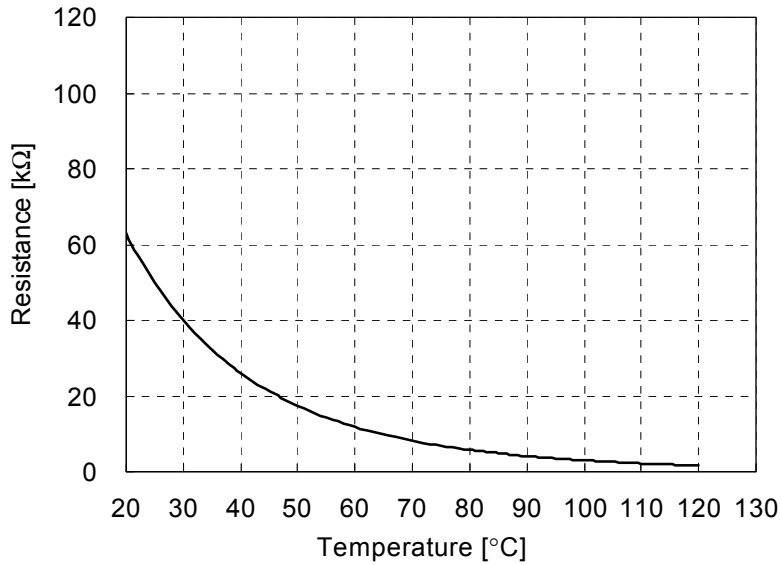
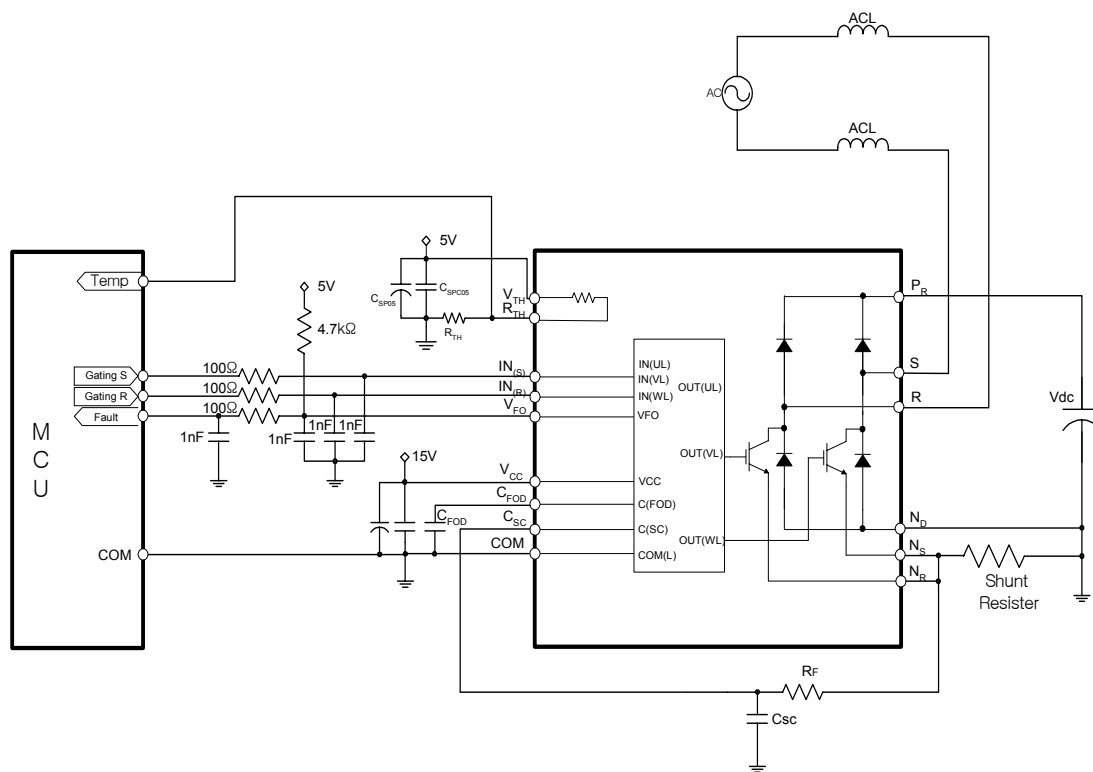

Figure 10. R-T Curve of the Built-in Thermistor

Note:

1. To avoid malfunction, the wiring of each input should be as short as possible. (less than 2-3cm)
2. V_{FO} output is open collector type. This signal line should be pulled up to the positive side of the 5V power supply with approximately 4.7k Ω resistance. Please refer to Figure 8.
3. V_{FO} output pulse width should be determined by connecting an external capacitor (C_{FOD}) between C_{FOD} (pin7) and COM(pin2). (Example : if $C_{FOD} = 33$ nF, then $t_{FO} = 1.8$ ms (typ.)) Please refer to the note 6 for calculation method.
4. Input signal is High-Active type. There is a 3.3k Ω resistor inside the IC to pull down each input signal line to GND. When employing RC coupling circuits, set up such RC couple that input signal agree with turn-off/turn-on threshold voltage.
5. To prevent errors of the protection function, the wiring around R_{SC} , R_F and C_{SC} should be as short as possible.
6. In the over current protection circuit, please select the $R_F C_{SC}$ time constant in the range 3~4 μ s.
7. Each capacitor should be mounted as close to the pins as possible.
8. Relays are used at almost every systems of electrical equipments of home appliances. In these cases, there should be sufficient distance between the CPU and the relays.

Figure 11. Application Circuit

Detailed Package Outline Drawings

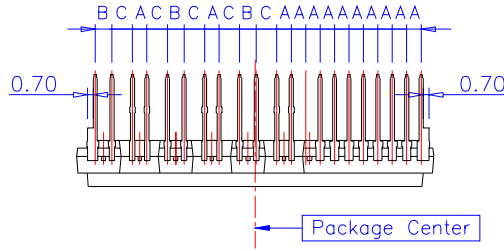

Lead Pitch : ± 0.30

A : 1.778

B : 2.050

C : 2.531

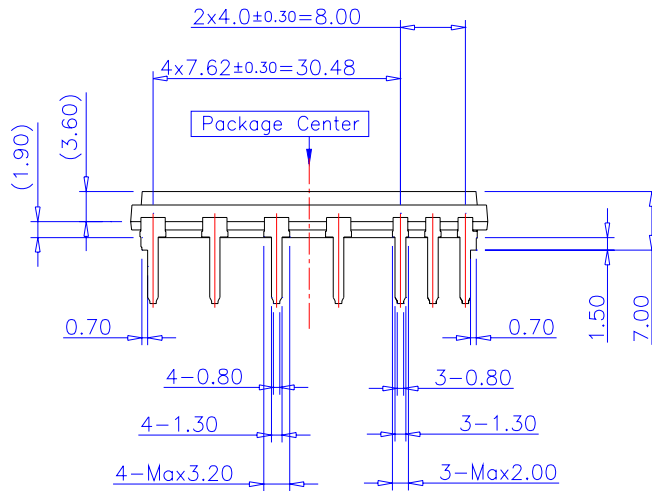
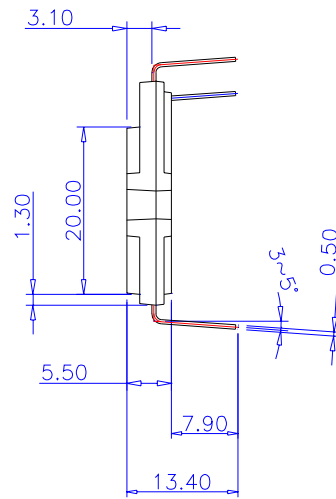
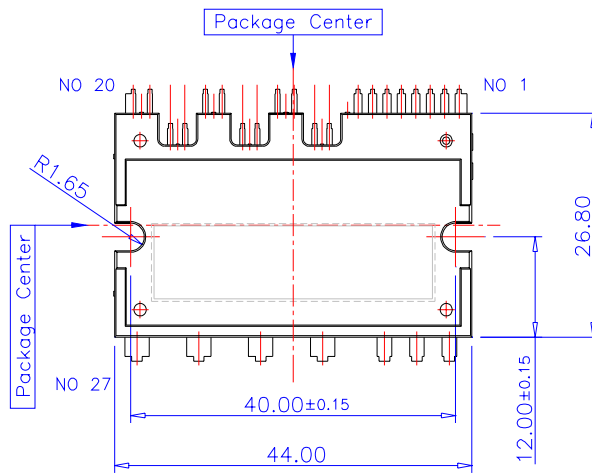

Detailed Package Outline Drawings (Continued)

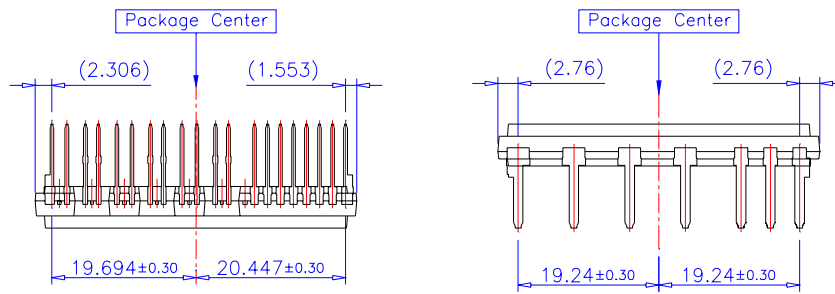
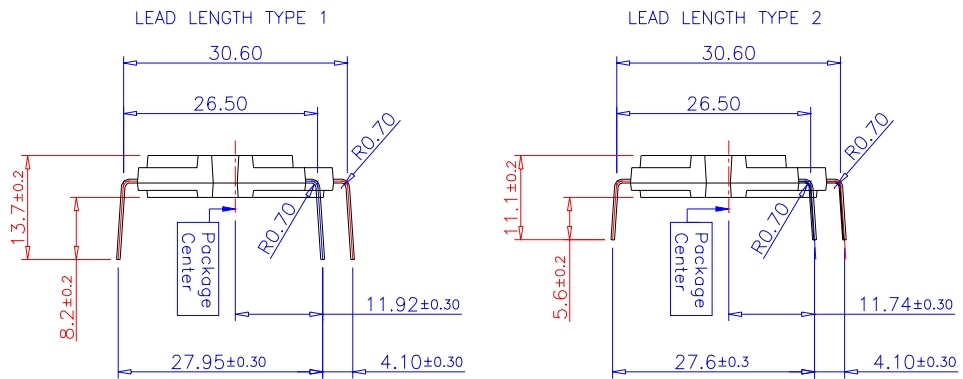

Detailed Package Outline Drawings (Continued)

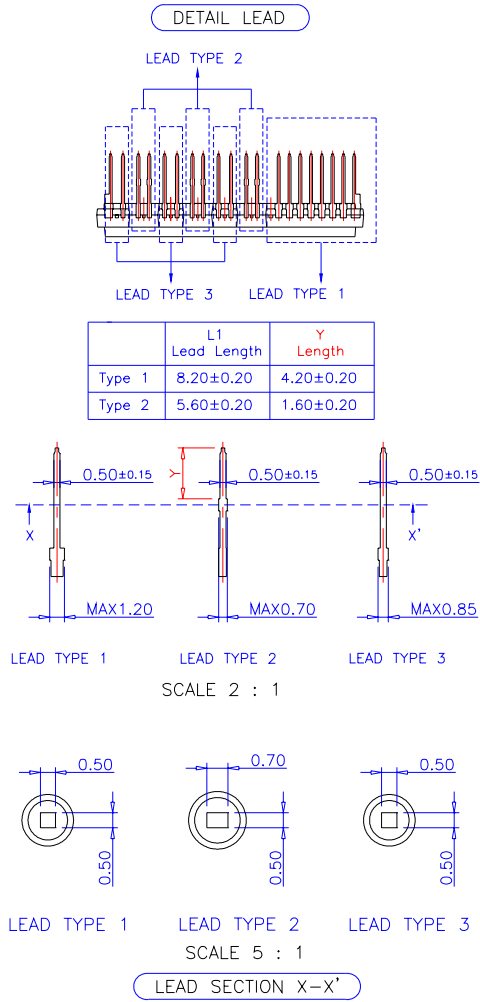

TRADEMARKS

The following are registered and unregistered trademarks Fairchild Semiconductor owns or is authorized to use and is not intended to be an exhaustive list of all such trademarks.

ACEx™	FAST®	ISOPLANAR™	PowerSaver™	SuperSOT™-8
ActiveArray™	FASTr™	LittleFET™	PowerTrench®	SyncFET™
Bottomless™	FPS™	MICROCOUPLER™	QFET®	TinyLogic®
Build it Now™	FRFET™	MicroFET™	QS™	TINYOPTO™
CoolFET™	GlobalOptoisolator™	MicroPak™	QT Optoelectronics™	TruTranslation™
CROSSVOLT™	GTO™	MICROWIRE™	Quiet Series™	UHC™
DOME™	HiSeC™	MSX™	RapidConfigure™	UltraFET®
EcoSPARK™	I ² C™	MSXPro™	RapidConnect™	UniFET™
E ² CMOS™	i-Lo™	OCX™	μSerDes™	VCX™
EnSigna™	ImpliedDisconnect™	OCXPro™	SILENT SWITCHER®	Wire™
FACT™	IntelliMAX™	OPTOLOGIC®	SMART START™	
FACT Quiet Series™		OPTOPLANAR™	SPM™	
Across the board. Around the world.™		PACMAN™	Stealth™	
The Power Franchise®		POP™	SuperFET™	
Programmable Active Droop™		Power247™	SuperSOT™-3	
		PowerEdge™	SuperSOT™-6	

DISCLAIMER

FAIRCHILD SEMICONDUCTOR RESERVES THE RIGHT TO MAKE CHANGES WITHOUT FURTHER NOTICE TO ANY PRODUCTS HEREIN TO IMPROVE RELIABILITY, FUNCTION OR DESIGN. FAIRCHILD DOES NOT ASSUME ANY LIABILITY ARISING OUT OF THE APPLICATION OR USE OF ANY PRODUCT OR CIRCUIT DESCRIBED HEREIN; NEITHER DOES IT CONVEY ANY LICENSE UNDER ITS PATENT RIGHTS, NOR THE RIGHTS OF OTHERS.

LIFE SUPPORT POLICY

FAIRCHILD'S PRODUCTS ARE NOT AUTHORIZED FOR USE AS CRITICAL COMPONENTS IN LIFE SUPPORT DEVICES OR SYSTEMS WITHOUT THE EXPRESS WRITTEN APPROVAL OF FAIRCHILD SEMICONDUCTOR CORPORATION.

As used herein:

1. Life support devices or systems are devices or systems which, (a) are intended for surgical implant into the body, or (b) support or sustain life, or (c) whose failure to perform when properly used in accordance with instructions for use provided in the labeling, can be reasonably expected to result in significant injury to the user.

2. A critical component is any component of a life support device or system whose failure to perform can be reasonably expected to cause the failure of the life support device or system, or to affect its safety or effectiveness.

PRODUCT STATUS DEFINITIONS

Definition of Terms

Datasheet Identification	Product Status	Definition
Advance Information	Formative or In Design	This datasheet contains the design specifications for product development. Specifications may change in any manner without notice.
Preliminary	First Production	This datasheet contains preliminary data, and supplementary data will be published at a later date. Fairchild Semiconductor reserves the right to make changes at any time without notice in order to improve design.
No Identification Needed	Full Production	This datasheet contains final specifications. Fairchild Semiconductor reserves the right to make changes at any time without notice in order to improve design.
Obsolete	Not In Production	This datasheet contains specifications on a product that has been discontinued by Fairchild semiconductor. The datasheet is printed for reference information only.

Rev. I16