ePVP6200

VFD Controller

**Product
Specification**

**VERSION
1.53**

ELAN MICROELECTRONICS CORP.
Nov 2004



Trademark Acknowledgments

IBM is a registered trademark and PS/2 is a trademark of IBM.

Microsoft, MS, MS-DOS, and Windows are registered trademarks of Microsoft Corporation.

© 2003 ELAN Microelectronics Corporation

All Rights Reserved

Printed in Taiwan, ROC, 05/252004 (Version 1.4)

The contents of in this specification are subject to change without notice. ELAN Microelectronics assumes no responsibility for errors that may appear in this specification. ELAN Microelectronics makes no commitment to update, or to keep current, the information contained in this specification. The software (if any) described in this specification is furnished under a license or nondisclosure agreement, and may be used or copied only in accordance with the terms of the agreement.

ELAN Microelectronics products are not intended for use in life support appliances, devices, or systems. Use of ELAN Microelectronics products in such application is not supported and is prohibited.

NO PART OF THIS SPECIFICATION MAY BE REPRODUCED OR TRANSMITTED IN ANY FORM OR BY ANY MEANS WITHOUT THE EXPRESS WRITTEN PERMISSION OF ELAN MICROELECTRONICS.

Specification Revision History		
Version	Revision Description	Date
1.0	Initial version	2003/6/15
1.3	Udata typesetting	
1.4	Revise pin assignment ADD Relevant Pins assigment ADD Relevant Pins assigment ADD APPLICATION CIRCUIT ADD Package Information Revices DC Electrical Characteristic Revices cpu Feature Describe additional remark SPI function	2004/06/23
1.5	additional remark Application notes	2004/9/16
1.51	Revised CONT register describe Udata Pckage Information	2004/9/23
1.52	IC name change	2004/11/4
1.53	additional remark Application notes Revised Feature describe Revised ROM size to 8k bytes Revised Operation Voltage VS PLL Operation frequency	2004/11/28



Contents

Read Me First!	vi
1 General Description	1
2. Feature	1
2.1 CPU	1
2.2 SPI.....	2
2.3 GPIO.....	2
2.4 VFD	2
2.5 POR.....	2
2.6 PACKAGE	2
3 Application	2
VFD controller	2
4 Pin Configuration	3
5 Functional Block Diagram	4
5.1 Ports Mapping for HV and GPIO	5
5.1.1 HV Port Mapping	5
5.1.2 GPIO Port Mapping	5
5.2 Relevant Pins for programming mode	5
6 Pin Descriptions	6
7 Function Descriptions	8
7.1 Operation Registers Configuration	8
7.2 Operation Registers Description	9
7.2.1 R0 (Indirect Address Register)	9
7.2.2 R1 (TCC)	9
7.2.3 R2 (Program Counter)	9
7.2.4 R3 (Status, Page Selection)	10
7.2.5 R4 (RAM Selection For Common Registers R20 ~ R3F)).....	12
7.2.6 R5 (PORT5 Output Data, Program Page Selection)	12
7.2.7 R6 (PORT6 Output Data, SPI Data Buffer)	13
7.2.8 R7 (PORT7 Output Data	14
7.2.9 R8 (PORT8 Output data, Data RAM address) , Counter2_LB data	14
7.2.10 R9 (PORT9 I/O Data, Data RAM Data Buffer), Counter2_HB Data	15

7.2.11	RA (PLL, Main Clock Selection, Watchdog Timer), Counter3 Data	16
7.2.12	PORT9 Switches)	18
7.2.13	RC (PORTC I/O Data , Counter5 Data).....	19
7.2.14	RD (Interrupt Flag,).....	19
7.2.15	RE (Interrupt Flags, Wake-up).....	20
7.2.16	RF (Interrupt Flags)	20
7.2.17	R10~R3F (General Purpose Registers)	21
7.3	Special Purpose Registers	21
7.3.1	A (Accumulator)	21
7.3.2	CONT (Control Register)	21
7.3.3	IOC 5 (PORT5 Switches)	23
7.3.4	IOC 8	23
7.3.5	IOC9 (PORT9 I/O Control)	24
7.3.6	IOCA	25
7.3.7	IOCC (PORTC I/O Control)	25
7.3.8	IOCD (Interrupt Mask, Prescaler of CN3 ~ CN5)	26
7.3.9	IOCE (Interrupt Mask)	26
7.3.10	IOCF (Interrupt Mask).....	26
7.4	Application notes	
7.5	I/O Port	29
7.6	RESET	29
7.7	Wake Up.....	30
7.6.1	SLEEP Mode, RA(6 ;7) = 0 + "SLEP" Instruction.....	30
7.6.2	IDLE mode, RA(6 ;7) = 1 + "SLEP" Instruction.	30
7.6.3	Wake-up from SLEEP Mode.....	31
7.6.4	Wake-up from IDLE Mode	31
7.8	Interrupts	31
7.9	Instruction Set	31
8	Segment Data Buffers	34
8.1	Commands	36
8.1.1	Display Mode Setting Command [00].....	37
8.1.2	Data Setting Command [01]	38
8.1.3	Display Control Command [10]	38
8.1.4	Address Setting Command [11].....	39



9	RC/Crystal OSC	40
9.1	General Description.....	40
9.2	Features	40
9.3	Block Diagram	40
9.4	Pin Description	40
9.5	Electrical.....	40
10	Absolute Operation Maximum Ratings	41
11	DC Electrical Characteristic	42
12	AC Electrical Characteristic	42
12.1	CPU Instruction Timing (Ta = -20°C ~ 70°C, VDD=5V, VSS=0V).....	42
12.2	AC Timing Characteristic (VDD=5V, Ta=+25°C)	43
12.3	ePVP6200 Operating Voltage (X Axis → Min VDD ; Y Axis → Main CLK)	43
12.4	AC Timing Diagrams	44
13	Key & Switch Scanning and Display Timing	45
14	Serial/Parallel Communication Format	46
14.1	Reception (Command/Data Write)	46
14.2	Transmission (Data Read)	46
15	Switching Characteristic Waveform	47
15.1	Switching Characteristics (Ta = - 20 to + 70°C, VDD = 4.5 to 5.5V, VEE = VDD - 45V)	
16	Serial I/F Sets Display Data Sequence	48
16.1	Updating Display Memory by Incrementing Address	48
16.2	Updating Specific Address	48
17	Application	49
17.1	VFD Controller for DVD Player	49
17.2	VFD Controller for Cascade Appliaication.....	49
17.3	Application circu	50
18	Package Information	

Read Me First!

Before using the chip, spare a few minutes to take a look at the following important notes.

1. Some bits in the registers are undefined. The values in these bits are unknown and should not be used. These bits are designated with a dash “-” symbol as its bit name in this specification.
2. The following table shows the definitions of the various register designations used to identify bit types, bit name, and bit number. Some definitions will appear quite frequently in the specification.

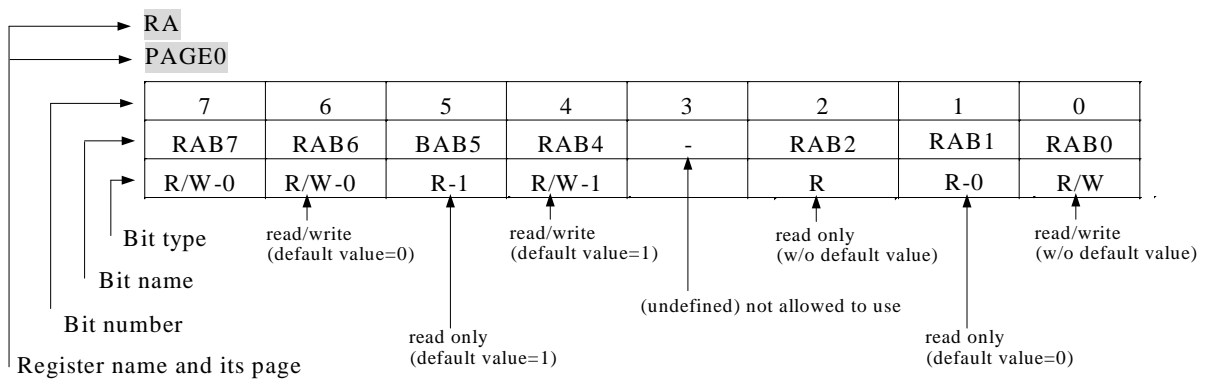



1 General Description

The ePVP6200 is an 8-bit RISC type vacuum fluorescent display (VFD) controller equipped with low power consumption and high speed CMOS technology. This integrated single chip features on_chip watchdog timer (WDT), one time programming ROM (OTP), data RAM, programmable real time clock/counter, internal interrupt, power down mode, built-in four-wire SPI, IR detector, and high voltage output for VFD application.

2. Feature

2.1 CPU

- **Clock source** : Crystal Oscillator
- Crystal Oscillator (32.768KHz): with a external crystal
- 8k x 13 on chip Program ROM.
- 256 x 8 on chip data RAM
- 144 x 8 general purpose registers
- 16 level stack for subroutine nesting
- **5 channel 8-bit counters:** real time clock/counter (TCC) ,COUNTER1, COUNTER3, COUNTER4, COUNTER5
- **1 channel 16-bit counter:** COUNTER2
- On-chip watchdog timer (WDT)
- 99.9% single instruction cycle commands
- Four operation modes

Mode	CPU Status	Main Clock	32.768kHz Clock Status	Description
Sleep mode	Turn off	Turn off	Turn off	RA(6) = 0 RA(7) = 0 + "SLEP" instruction
Idle mode	Turn off	Turn off	Turn on	RA(6) = 0 RA(7) = 1 +"SLEP" instruction.
Green mode	Turn on	Turn off	Turn on	RA(6) = 0
Normal mode	Turn on	Turn on	Turn on	RA(6) = 1

* Main clock can be programmed from 447.829k to 17.91MH by internal PLL

* **8 main clocks:** 447.829K, 895.658K, 1.791M , 3.582M , 7.165M , 10.747M ,
14.331M and 17.91MHz

- 12 interrupt source, 5 external (IR , INT1~INT4) , 7 internal (SPI, TCC, COUNTER1~5)

2.2 SPI

- Serial interface for Clock, Data Input, Data Output, and Strobe pins



2.3 GPIO

- GPIO 9 Port(8 bit): general purpose input/output; LED output ;interrupt function
- GPIO C Port(8 bit): general purpose input/output for switch and key scanning (12x4 matrix)

2.4 VFD

- Multiple display modes (9-segment & 19-digit to 20-segment & 8-digit)
- External resistor not necessary for driver outputs.(P-ch open-drain + pull-down resistor output)

2.5 POR

2.0V voltage detector for Power-on reset

2.6 PACKAGE

52-pin QFP

3 Application

VFD controller

4 Pin Configuration

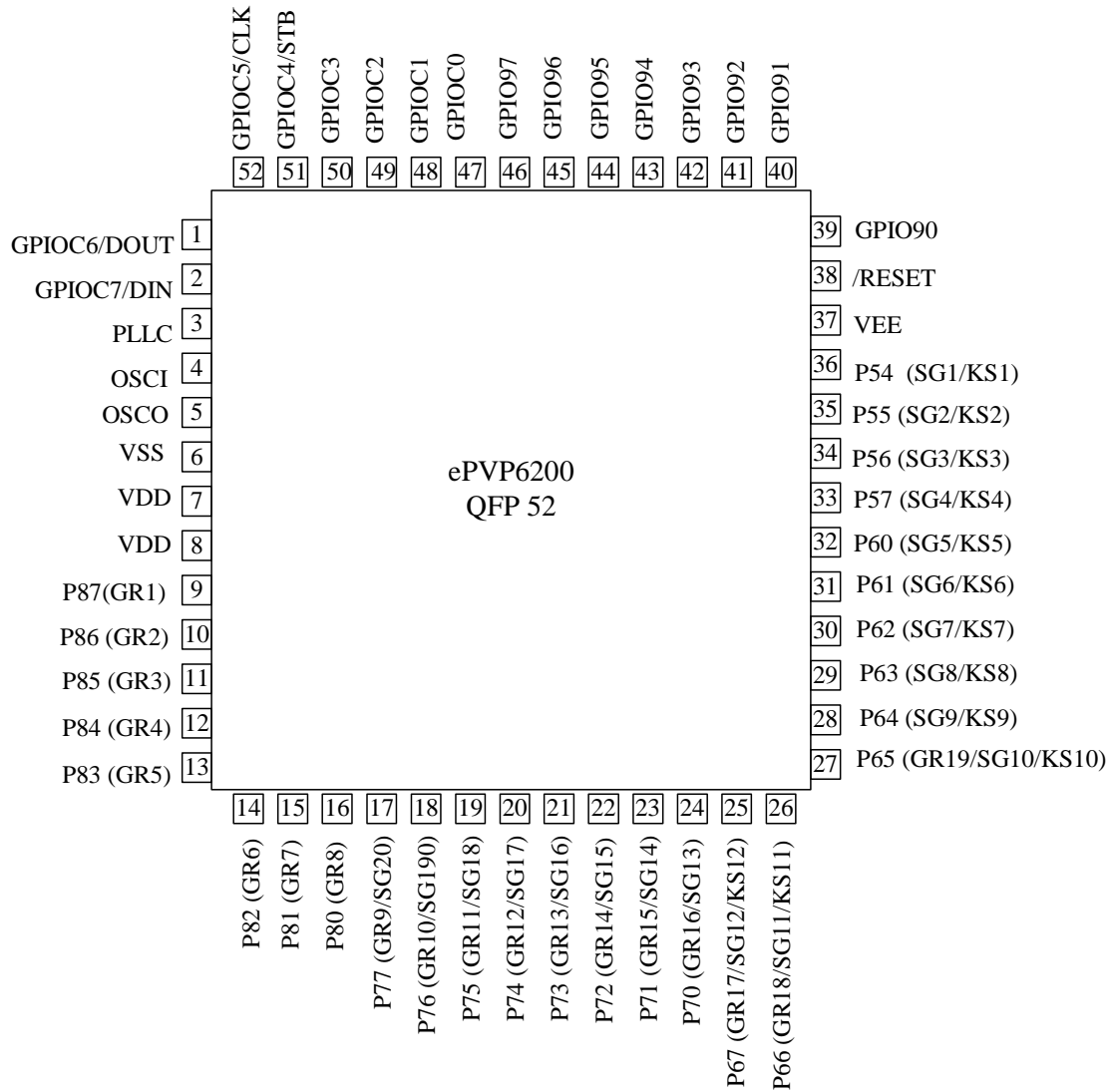

Fig. 1 Pin Assignment

5 Functional Block Diagram

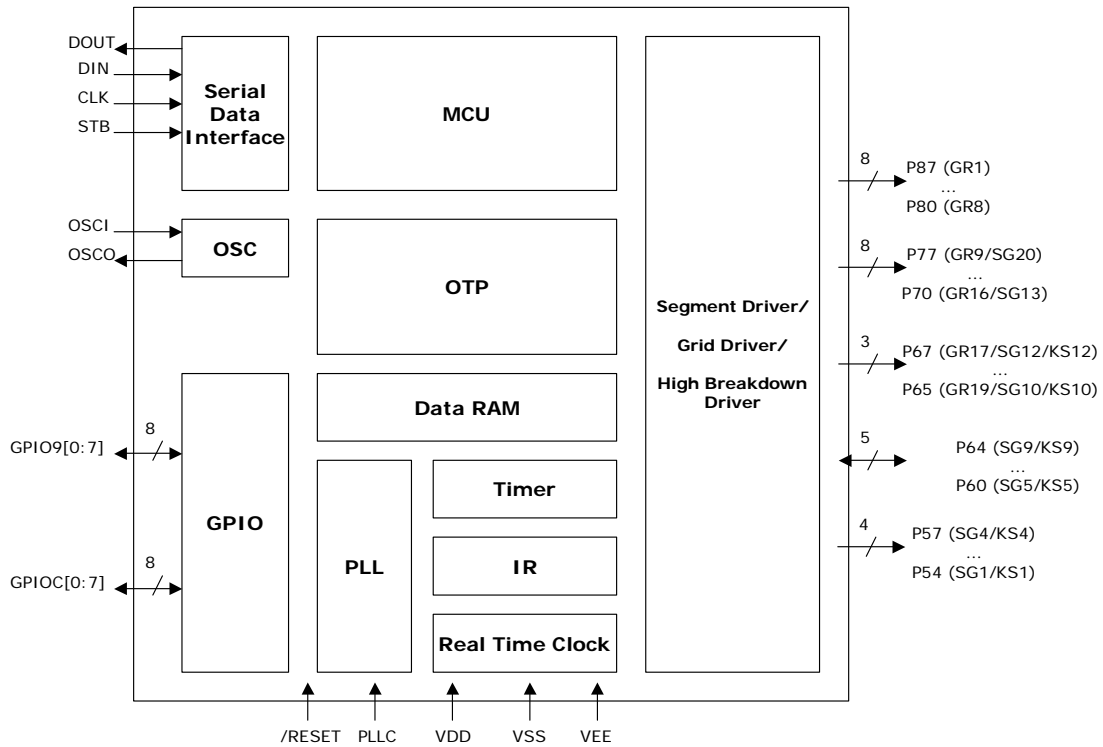

Fig. 2a Block Diagram

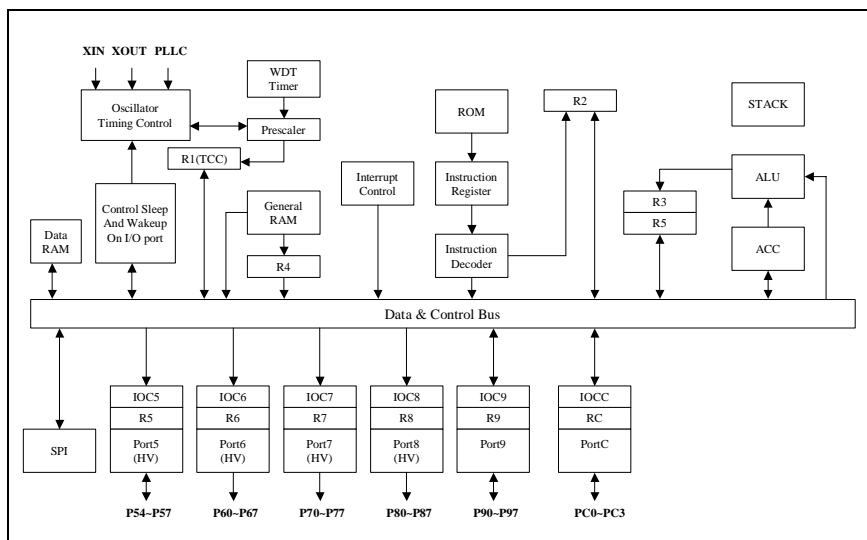

Fig. 2b Block Diagram



5.1 Ports Mapping for HV and GPIO

5.1.1 HV Port Mapping

Port	HV	Port	HV	Port	HV	Port	HV
-		P60	SG5/KS5	P70	GR16/SG13	P80	GR8
-		P61	SG6/KS6	P71	GR15/SG14	P81	GR7
-		P62	SG7/KS7	P72	GR14/SG15	P82	GR6
-		P63	/SG8/KS8	P73	GR13/SG16	P83	GR5
P54	SG1/KS1	P64	SG9/KS9	P74	GR12/SG17	P84	GR4
P55	SG2/KS2	P65	GR19/SG10/KS10	P75	GR11/SG18	P85	GR3
P56	SG3/KS3	P66	GR18/SG11/KS11	P76	GR10/SG19	P86	GR2
P57	SG4/KS4	P67	GR17/SG12/KS12	P77	GR9/SG20	P87	GR1

5.1.2 GPIO Port Mapping

Port	GPIO	Port	GPIO
P90	GPIO90/LED0/IR	PC0	GPIOC0/Key1
P91	GPIO91/LED1/INT1	PC1	GPIOC1/Key2
P92	GPIO92/LED2/INT2	PC2	GPIOC2/Key3
P93	GPIO93/LED3/INT3	PC3	GPIOC3/Key4
P94	GPIO94/LED4/INT4	PC4	GPIOC4/STB
P95	GPIO95/LED5	PC5	GPIOC5/CLK
P96	GPIO96/LED6	PC6	GPIOC6/DOUT
P97	GPIO97/LED7	PC7	GPIOC7/ DIN

5.2 Relevant Pins for programming mode

OTP PIN NAME	MASK ROM PIN NAME
VDD	AVDD
VPP	/RESTER
DINCK	PC3
ACLK	PC2
PGMB	P92
OEB	P91
DATA	P90
GND	GND

6 Pin Descriptions

Pin No.	Pin Name	I/O	#	Description	Note
7,8	VDD	-	2	Logic power supply	
51	STB/GPIOC4	I/O	1	<ol style="list-style-type: none"> 1. Serial Interface Strobe input pin. While the STB goes low, it will cause interrupt event. The data input after the STB has fallen is processed as a command. When this pin is "HIGH," CLK is ignored. 2. Programmable Internal pull high 3. GPIOC4 function 	Schmitt Pull-up
52	CLK/GPIOC5	I/O	1	<ol style="list-style-type: none"> 1. Clock input pin. This pin reads serial data at the rising edge and outputs data at the falling edge. 2. Programmable Internal pull high 3. GPIOC5 function 	Schmitt Pull-up
1	DOUT/GPIOC6	I/O	1	<ol style="list-style-type: none"> 1. Data output pin (N-channel, Open-Drain) 2. This pin outputs serial data at the falling edge of the shift clock (starting from lower bit). 3. Programmable internal pull high 4. GPIOC6 function 	Schmitt Pull-up
2	DIN/GPIOC7	I/O	1	<ol style="list-style-type: none"> 1. Data input pin. This pin inputs serial data at the rising edge of the shift clock (starting from lower bit.) 2. Programmable Internal pull high 3. GPIOC7 function 	Schmitt Pull-up
47~50	GPIOC0 – GPIOC3	I/O	4	<p>General Purpose I/O pins:</p> <ol style="list-style-type: none"> 1. Key data input to these pins is latched at the end of display cycle. 2. These pins constitute 4-bit general-purpose input/output port. 3. Programmable Internal Pull-High 4. Wake-up Function 	Schmitt Pull-up
9~16	GR1– GR8	O	8	<ol style="list-style-type: none"> 1. High voltage grid output 	~
17~24	GR9 /SG20 – GR16 /SG13	O	8	<ol style="list-style-type: none"> 1. High voltage grid output 2. High voltage segment output 	
25~27	GR17/SG12/KS12 – GR19/SG10/KS10	O	3	<ol style="list-style-type: none"> 1. High voltage grid output 2. High voltage segment output 3. Matrix key scan output 	
28~32	P20/SG9/KS9 – P24/SG5/KS5	O	5	<ol style="list-style-type: none"> 1. High voltage segment output 2. Matrix key scan output 	
33~36	SG4/KS4 – SG1/KS1	I/O	4	<ol style="list-style-type: none"> 1. High voltage segment output 2. Matrix key scan output 3. General Purpose Input pins: p54~p57 	
40~46	GPIOC9/LED0 – GPIOC7/LED7	I/O	8	<ol style="list-style-type: none"> 1. General Purpose I/O pins 2. LED output pin (20mA) 3. IR Detector 	Schmitt Pull-up



				4. Interrupt Function 5. Programmable Internal Pull-High	
3	PLLC	I	1	Phase Lock Loop Capacitor (connect a Capacitor 0.01 to 0.047u to the Ground).	
4	OSCI	I	1	Crystal Oscillator input pin (32, 768Hz)	
5	OSCO	O	1	Crystal Oscillator output pin (32, 768Hz)	
6	VSS	-	1	Connect this pin to GND of the system	
38	/RESET	I	1	Low active RESET signal input	Schmitt
37	VEE	-	1	Pull-down level (VDD-(-40V)max)	



7 Function Descriptions

7.1 Operation Registers Configuration

Addr	R PAGE Registers		
	R PAGE0	R PAGE1	R PAGE2
00	Indirect addressing		
01	TCC		
02	PC		
03	Page, Status		
04	RAM bank, RSR		
05	Port5 Output data	Program ROM page	
06	Port6 Output data		SPI data buffer
07	Port7 Output data		Counter1 data
08	Port8 Output data	Data RAM address	Counter2 LB data
09	Port9 I/O data	Data RAM data buffer	Counter2 HB data
0A	PLL, Main clock,WDTE		Counter3 data
0B		Port9 pull high	Counter4 data
0C	PortC I/O data	PortC pull high	Counter5 data
0D	Interrupt flag		
0E	Interrupt flag, Wake-up control		
0F	Interrupt flag		
10 : 1F	16 bytes Common registers		
20 : 3F	Bank0 ~ Bank3 Common registers (32x8 for each bank)		

Addr	IOC PAGE Registers	
	IOC PAGE0	IOC PAGE1
00		
01		
02		
03		
04		
05		Port5 switch
06		
07		
08		Clock source (CN2,CN1) Prescaler (CN2,CN1)
09	Port9 I/O control	Clock source (CN4,CN3) Prescaler (CN4,CN3)
0A		Clock source (CN5) Prescaler (CN5)
0B		
0C	PortC I/O control	PortC switch
0D	Interrupt mask	
0E	Interrupt mask	
0F	Interrupt mask	

7.2 Operation Registers Description

7.2.1 R0 (Indirect Address Register)

R0 is not a physically implemented register. It is used as indirect address pointer. Any instruction using R0 as register actually accesses data pointed by the RAM Select Register (R4).

Example:

```
Mov A, @0x20      ;store an address at R4 for indirect address
Mov 0x04, A
Mov A, @0xAA      ;write data 0xAA to R20 at Bank0 through R0
Mov 0x00, A
```

7.2.2 R1 (TCC)

TCC data buffer. Increased by 16.384KHz or by the instruction cycle clock (controlled by CONT register).

Written and read by the program as any other register.

7.2.3 R2 (Program Counter)

The structure is depicted in Fig.3 below.

Generates $8k \times 13$ external ROM addresses to the relative programming instruction codes.

"JMP" instruction allows the direct loading of the low 10 program counter bits.

"CALL" instruction loads the low 10 bits of the PC, PC+1, and then push into the stack.

"RET" ("RETL k," "RETI") instruction loads the program counter with the contents at the top of stack.

"MOV R2, A" allows the loading of an address from the A register to the PC, and the ninth and tenth bits are cleared to "0".

"ADD R2, A" allows a relative address to be added to the current PC, and contents of the ninth and tenth bits are cleared to "0".

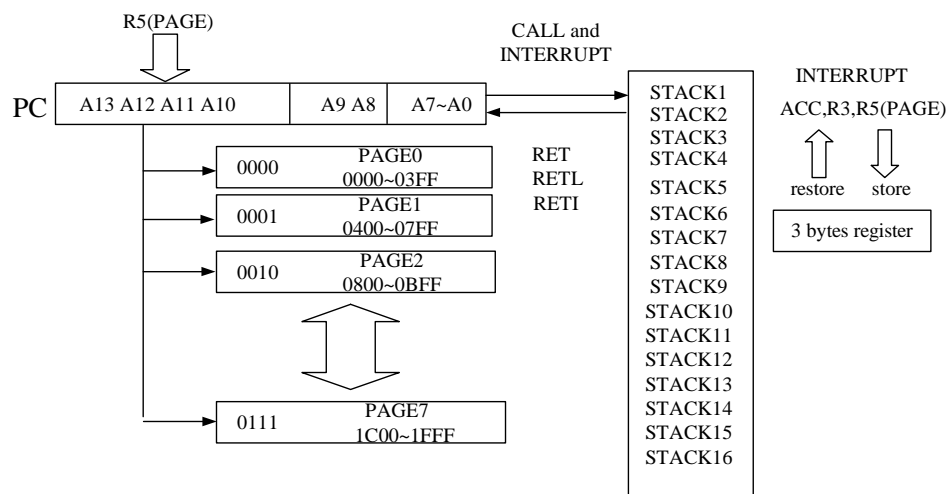

Fig. 3 Program Counter Organization



"TBL" allows a relative address to be added to the current PC, and the contents of the ninth and tenth bits do not change. The most significant bit (A10~A13) will be loaded with the contents of bit PS0~PS3 in the status register (R5 PAGE 1) upon execution of a "JMP," "CALL," "ADD R2, A." or "MOV R2, A" instruction.

If an interrupt is triggered, PROGRAM ROM will jump to address 0x08 at Page0. The CPU will automatically store ACC, R3 status, and R5 PAGE 1, and they will be restored after execution of instruction RETI.

7.2.4 R3 (Status, Page Selection)

(Status Flag, Page Selection Bits)

Bit 7	Bit 6	Bit 5	Bit 4	Bit 3	Bit 2	Bit 1	Bit 0
RPAGE1	RPAGE0	IOCPAGE	T	P	Z	DC	C
R/W-0	R/W-0	R/W-0	R	R	R/W	R/W	R/W

Bit 0 (C) : Carry flag

The carry flag is affected by following operation :

- a. Addition : CF as a carry out indicator, when the addition operation has a carry-out, CF will be "1", in another word, if the operation has no carry-out, CF will be "0".
- b. Subtraction : CF as a borrow-in indicator, when the subtraction operation must has a borrow-in, the CF will be "0", in another word, if no borrow-in, CF will be "1".
- c. Comparison : CF is as a borrow-in indicator for Comparison operation as the same as subtraction operation.
- d. Rotation : CF shifts into the empty bit of accumulator for the rotation and holds the shift out data after rotation.

Bit 1 (DC) : Auxiliary carry flag

Bit 2 (Z) : Zero flag

ZF is affected by the result of ALU, if the ALU operation generate a "0" result, the ZF will be "1", otherwise, the ZF will be "0".

Bit 3 (P) : Power down bit

Set to 1 during power on or by a "WDTC" command and reset to 0 by a "SLEP" command.



Bit 4 (T) : Time-out bit
Set to 1 by the "SLEP" and "WDTC" command, or during power up and reset to 0 by WDT timeout.

Event	T	P	Remarks
WDT wake up from sleep mode	0	0	
WDT time out (not sleep mode)	0	1	
/RESET wake up from sleep	1	0	
Power up	1	1	
Low pulse on /RESET	x	X	x : don't care

Bit 5 (IOCPAGE) : Change IOC5 ~ IOCE to another page
0/1 → IOC page0 / IOC page1

Bit 6 (RPAGE0 ~ RPAGE1) : Change R5 ~ RC to another page (see Section 7.1 *Operation Registers Configuration* for details.)

(RPAGE1, RPAGE0)	R page # selected
(0,0)	R page 0
(0,1)	R page 1
(1,x)	R page 2



7.2.5 R4 (RAM Selection For Common Registers R20 ~ R3F)

(RAM Selection Register)

Bit 7	Bit 6	Bit 5	Bit 4	Bit 3	Bit 2	Bit 1	Bit 0
RB1	RB0	RSR5	RSR4	RSR3	RSR2	RSR1	RSR0
R/W-0	R/W-0	R/W	R/W	R/W	R/W	R/W	R/W

Bit 0 ~ Bit 5 (RSR0 ~ RSR5) : Indirect address for common Registers R20 ~ R3F.

RSR bits are used to select up to 32 registers (R20 to R3F) in the indirect address mode.

Bit 6 ~ Bit 7 (RB0 ~ RB1) : Bank selection bits for common Registers R20 ~ R3F.

These selection bits are used to determine which bank is activated among the 4 banks for 32 register (R20 to R3F). Refer to Section 7.1 *Operation Registers Configuration* for details.

7.2.6 R5 (PORT5 Output Data, Program Page Selection)

a) PAGE 0 (PORT5 Output Data Register for HV or General Purpose Input pins:)

Bit 7	Bit 6	Bit 5	Bit 4	Bit 3	Bit 2	Bit 1	Bit 0
P57	P56	P55	P54	-	-	-	-
W-0	W-0	W-0	W-0	-	-	-	-

b) PAGE 1 (Program ROM Page Register)

Bit 7	Bit 6	Bit 5	Bit 4	Bit 3	Bit 2	Bit 1	Bit 0
-	-	-	-	-	PS2	PS1	PS0
-	-	R/W-0	R/W-0	R/W-0	R/W-0	R/W-0	R/W-0

Bit 0 ~ Bit 2 (PS0 ~ PS2) : Program page selection bits

PS2	PS1	PS0	Program Memory Page (Address)
0	0	0	Page 0
0	0	1	Page 1
0	1	0	Page 2
0	1	1	Page 3
1	0	0	Page 4
1	0	1	Page 5
1	1	0	Page 6
1	1	1	Page 7

PAGE instruction is used to select the program page to be accessed. The selected program page is maintained by Elan compiler. PAGE instruction will change your program by inserting the instruction within program.

7.2.7 R6 (PORT6 Output Data, SPI Data Buffer)

a) PAGE 0 (PORT6 Output Data Register for HV)

Bit 7	Bit 6	Bit 5	Bit 4	Bit 3	Bit 2	Bit 1	Bit 0
P67	P66	P65	P64	P63	P62	P61	P60
W-0	W-0	W-0	W-0	W-0	W-0	W-0	W-0

b) PAGE 2 (SPI Data Buffer)

Bit 7	Bit 6	Bit 5	Bit 4	Bit 3	Bit 2	Bit 1	Bit 0
SPIB7	SPIB6	SPIB5	SPIB4	SPIB3	SPIB2	SPIB1	SPIB0
R/W	R/W	R/W	R/W	R/W	R/W	R/W	R/W

Bit 0 ~ Bit 7 (SPIB0 ~ SPIB7) : SPI data buffer

If you write data to this register, the data will write to SPIW register. If you read this data, it will read the data from SPIR register. Please refer to the following figure.

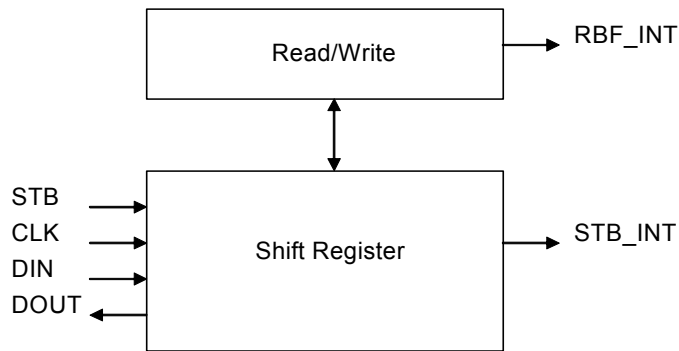
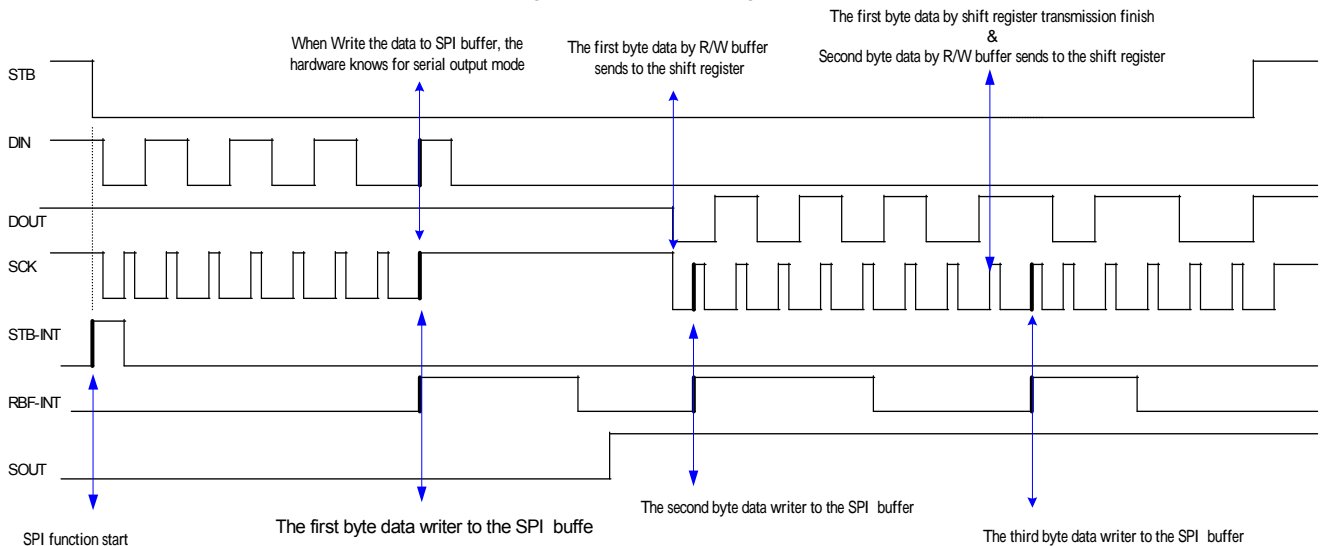

Fig. 4a SPI Block Diagram



SPI data transmission application note::
 The following conditions have to conform
 RBF interrupt flag must =1
 RBF interrupt mask must =1
 STB must = low
 CLK must = Hi

Fig. 4b SPI Timing Diagram



7.2.8R7 (PORT7 Output Data , Counter1 Data

a) PAGE 0 (PORT7 Output Data Register for HV)

Bit 7	Bit 6	Bit 5	Bit 4	Bit 3	Bit 2	Bit 1	Bit 0
P77	P76	P75	P74	P73	P72	P71	P70
W-0	W-0	W-0	W-0	W-0	W-0	W-0	W-0

b) PAGE 2 (Counter 1 Data Register)

Bit 7	Bit 6	Bit 5	Bit 4	Bit 3	Bit 2	Bit 1	Bit 0
CN17	CN16	CN15	CN14	CN13	CN12	CN11	CN10
R/W-0	R/W-0	R/W-0	R/W-0	R/W-0	R/W-0	R/W-0	R/W-0

Bit 0 ~ Bit 7 (CN10 ~ CN17) : Counter1 buffer that you can read and write.

Counter1 is an 8-bit up-counter with 8-bit prescaler that allows you to use R7 PAGE2 to preset and read the counter (write → preset). After an interruption, it will reload the preset value.

7.2.9 R8 (PORT8 Output data, Data RAM address) , Counter2_LB data

a) PAGE 0 (PORT8 Output Data Register for HV)

Bit 7	Bit 6	Bit 5	Bit 4	Bit 3	Bit 2	Bit 1	Bit 0
P87	P86	P85	P84	P83	P82	P81	P80
W-0	W-0	W-0	W-0	W-0	W-0	W-0	W-0

b) PAGE 1 (Data RAM Address Register)

Bit 7	Bit 6	Bit 5	Bit 4	Bit 3	Bit 2	Bit 1	Bit 0
RAM_A7	RAM_A6	RAM_A5	RAM_A4	RAM_A3	RAM_A2	RAM_A1	RAM_A0
R/W-0	R/W-0	R/W-0	R/W-0	R/W-0	R/W-0	R/W-0	R/W-0

Bit 0 ~ Bit 7 (RAM_A0 ~ RAM_A7) : data RAM address

c) PAGE 2 (Counter2 Low Byte Data Register)

Bit 7	Bit 6	Bit 5	Bit 4	Bit 3	Bit 2	Bit 1	Bit 0
CN27	CN26	CN25	CN24	CN23	CN22	CN21	CN20
R/W	R/W	R/W	R/W	R/W	R/W	R/W	R/W

Bit 0 ~ Bit 7 (CN20 ~ CN27) : Counter2_LB's buffer that you can read and write.

Counter2 is a 16-bit up-counter with 8-bit prescaler that allows you to use R8 PAGE2 to preset and read the counter.(write → preset). After an interruption, it will reload the preset value.

7.2.10 R9 (PORT9 I/O Data, Data RAM Data Buffer) ,Counter2_HB Data

a) PAGE 0 (PORT9 I/O Data Register)

Bit 7	Bit 6	Bit 5	Bit 4	Bit 3	Bit 2	Bit 1	Bit 0
P97	P96	P95	P94	P93	P92	P91	P90
R/W	R/W	R/W	R/W	R/W	R/W	R/W	R/W

Bit 0 ~ Bit 7 (P90 ~ P97) : 8-bit PORT9(0~7) I/O data register

You can use IOC register to define input or output each bit, and to define the pull high condition.

Bit 0:

1. P90 : can be defined as Input/Output
2. LED0 : can be defined as Output
3. IR Input : can be defined as Input and IR is enabled (when IOCF Bit7 is set to 1)

Bit 1 ~ Bit4:

1. P91~P94 : can be defined as Input/Output
2. LED1~LED4 : can be defined as Output
3. INT1~INT4 : can be defined as Input

Bit 5 ~ Bit7:

1. P95~P97 : can be defined as Input/Output
2. LED5~LED7 : can be defined as Output

b) PAGE 1 (Data RAM Data Register)

Bit 7	Bit 6	Bit 5	Bit 4	Bit 3	Bit 2	Bit 1	Bit 0
RAM_D7	RAM_D6	RAM_D5	RAM_D4	RAM_D3	RAM_D2	RAM_D1	RAM_D0
R/W	R/W	R/W	R/W	R/W	R/W	R/W	R/W

Bit 0 ~ Bit 7 (RAM_D0 ~ RAM_D7) : Data RAM's data

c) PAGE 2 (Counter2 High Byte Data Register)

Bit 7	Bit 6	Bit 5	Bit 4	Bit 3	Bit 2	Bit 1	Bit 0
CN215	CN214	CN213	CN212	CN211	CN210	CN29	CN28
R/W	R/W	R/W	R/W	R/W	R/W	R/W	R/W

Bit 0 ~ Bit 7 (CN28 ~ CN215) : Counter2_HB's buffer that you can read and write.

Counter2 is a 16-bit up-counter with 8-bit prescaler that allows you to use R9 PAGE2 to preset and read the counter (write → preset). After an interruption, it will reload the preset value.

7.2.11 RA (PLL, Main Clock Selection, Watchdog Timer), Counter3 Data

a) PAGE 0 (PLL Enable Bit, Main Clock Selection Bits, Watchdog Timer Enable Bit)

Bit 7	Bit 6	Bit 5	Bit 4	Bit 3	Bit 2	Bit 1	Bit 0
IDLE	PLLEN	CLK2	CLK1	CLK0	-	-	WDTEN
R/W-0	R/W-0	R/W-0	R/W-1	R/W-1			R/W-0

Bit 0 (WDTEN) : Watch dog control bit

You can use WDTEN instruction to clear watch dog counter. The counter clock source is 32768/2 Hz. If the prescaler is assigned to TCC, Watch dog will time out by $(1/32768) * 2 * 256 = 15.616\text{mS}$. If the prescaler is assigned to WDT, the time out interval will be longer depending on the prescaler. Ratio.

0/1 → disable/enable

Bit 1~Bit 2 : Unused

Bit 3 ~ Bit 5 (CLK0 ~ CLK2) : MAIN clock selection bits

You can select different frequencies for the main clock with CLK1 and CLK2. All the available clock selections are listed below.

PLLEN	CLK2	CLK1	CLK0	Sub clock	MAIN clock	CPU clock
1	0	0	0	32.768kHz	447.829kHz	447.829kHz (Normal mode)
1	0	0	1	32.768kHz	895.658kHz	895.658kHz (Normal mode)
1	0	1	0	32.768kHz	1.791MHz	1.791MHz (Normal mode)
1	0	1	1	32.768kHz	3.582MHz	3.582MHz (Normal mode)
1	1	0	0	32.768kHz	7.165MHz	7.165MHz (Normal mode)
1	1	0	1	32.768kHz	10.747MHz	10.747MHz (Normal mode)
1	1	1	0	32.768kHz	14.331MHz	14.331MHz (Normal mode)
1	1	1	1	32.768kHz	17.91MHz	17.91MHz (Normal mode)
0	Don't care	Don't care	Don't care	32.768kHz	Don't care	32.768kHz (Green mode)

Bit 6 (PLLEN) : PLL's power control bit which is CPU mode control register

0/1 → disable PLL/enable PLL

If PLL is enabled, CPU will operate at normal mode (high frequency). Otherwise, it will run at green mode (low frequency, 32768 Hz).

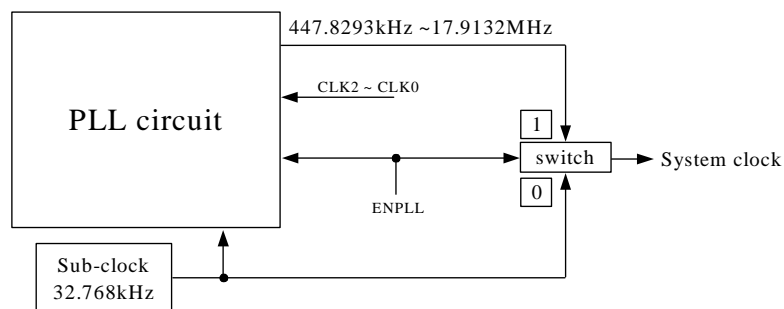

Fig. 6 The Relation Between 32.768kHz and PLL



Bit 7 (IDLE) : SLEEP or IDLE mode control as set by SLEP instruction.

0/1 → SLEEP mode/IDLE mode.

This bit allows SLEP instruction to decide which power saving mode to execute. The status after wake-up and the wake-up source list is as the shown below.

Wakeup Signal	SLEEP Mode	IDLE Mode
	RA(7,6)=(0,0) + SLEP	RA(7,6)=(1,0) + SLEP
TCC time out IOCF Bit0=1	No function	1) Wake-up 2) Jump to next instruction after SLEP
COUNTER1 time out IOCF Bit1=1	No function	1) Wake-up 2) Jump to next instruction after SLEP
COUNTER2 time out IOCF Bit2=1	No function	1) Wake-up 2) Jump to next instruction after SLEP
COUNTER3 time out IOCD Bit0=1	No function	1) Wake-up 2) Jump to next instruction after SLEP
COUNTER4 time out IOCD Bit1=1	No function	1) Wake-up 2) Jump to next instruction after SLEP
COUNTER5 time out IOCD Bit2=1	No function	1) Wake-up 2) Jump to next instruction after SLEP
PORT90(IR function) IOCF Bit3=1	Reset and jump to Address 0	1) Wake-up 2) Jump to next instruction after SLEP
WDT time out	Reset and jump to Address 0	1) Wake-up 2) Next instruction
PORTC(0~3)(Key1~Key4) RE PAGE0 Bit3 or Bit4 or Bit5 or Bit6 = 1	Reset and Jump to Address 0	1) Wake-up 2) Jump to next instruction after SLEP
PORT9(1~4) IOCF Bit4 or Bit5 or Bit6 =1 or Bit7=1	Reset and Jump to Address 0	1) Wake-up 2) Jump to next instruction after SLEP

- NOTES:**
1. PORT90 wakeup function is controlled by IOCF Bit 3. It is a falling edge or rising edge trigger (controlled by CONT register Bit7).
 2. PORT91 wakeup function is controlled by IOCF Bit 4. It is a falling edge trigger.
 3. PORT92 ~ PORT94 wakeup functions are controlled by IOCF. They are falling edge triggers.
 4. PORTC0 ~ PORTC3 wakeup functions are controlled by RE PAGE0 Bit 0 ~ Bit 3. They are falling edge triggers.



b) PAGE 2 (Counter3 Data Register)

Bit 7	Bit 6	Bit 5	Bit 4	Bit 3	Bit 2	Bit 1	Bit 0
CN37	CN36	CN35	CN34	CN33	CN32	CN31	CN30
R/W-0	R/W-0	R/W-0	R/W-0	R/W-0	R/W-0	R/W-0	R/W-0

Bit 0 ~ Bit 7 (CN30 ~ CN37) : Counter3's buffer that you can read and write.

Counter3 is an 8-bit up-counter with 8-bit prescaler that allows you to use RA PAGE2 to preset and read the counter (write → preset). After an interruption, it will reload the preset value.

7.2.12 RB (PORT9 Switches)

a) PAGE 1 (PORT9, Pull High)

Bit 7	Bit 6	Bit 5	Bit 4	Bit 3	Bit 2	Bit 1	Bit 0
PH97	PH96	PH95	PH94	PH93	PH92	PH91	PH90
R/W-0	R/W-0	R/W-0	R/W-0	R/W-0	R/W-0	R/W-0	R/W-0

Bit 0 ~ Bit 7 (PH90 ~ PH97) : PORT9 Bit0 ~ Bit7 pull high control register

0 → disable pull high function.

1 → enable pull high function

b) PAGE 2 (Counter4 Data Register)

Bit 7	Bit 6	Bit 5	Bit 4	Bit 3	Bit 2	Bit 1	Bit 0
CN47	CN46	CN45	CN44	CN43	CN42	CN41	CN40
R/W-0	R/W-0	R/W-0	R/W-0	R/W-0	R/W-0	R/W-0	R/W-0

Bit 0 ~ Bit 7 (CN40 ~ CN47) : Counter4 buffer that you can read and write.

Counter 4 is an 8-bit up-counter with 8-bit prescaler that allows you to use RB PAGE2 to preset and read the counter.(write → preset). After an interruption, it will reload the preset value.

7.2.13 RC (PORTC I/O Data , Counter5 Data)

a) PAGE 0 I/O Data Buffer/Serial Signal

Bit 7	Bit 6	Bit 5	Bit 4	Bit 3	Bit 2	Bit 1	Bit 0
PC7	PC6	PC5	PC4	PC3	PC2	PC1	PC0
R/W	R/W	R/W	R/W	R/W	R/W	R/W	R/W

Bit 0 ~ Bit 3 :1. PC0 ~ PC3 are defined as Input/Output
2. KEY1 ~ KEY4 are defined as Keyscan Input

Bit 4 :1. PC4 is defined as Input/Output
2. STB = Serial strobe signal

Bit 5 :1. PC5 is defined as Input/Output
2. CLK = Serial clock signal

Bit 6 :1. PC6 is defined as Input/Output
2. SDO = Serial data out

Bit 7 :1. PC7 is defined as Input/Output
2. SDI = Serial data in

b) PAGE 1 (PORTC, Pull High)

Bit 7	Bit 6	Bit 5	Bit 4	Bit 3	Bit 2	Bit 1	Bit 0
PHC7	PHC6	PHC5	PHC4	PHC3	PHC2	PHC1	PHC0
R/W-0	R/W-0	R/W-0	R/W-0	R/W-0	R/W-0	R/W-0	R/W-0

Bit 0 ~ Bit 7 (PHC0 ~ PHC7) : PORTC Bit0 ~ Bit7 pull high control register
0 → disable pull high function.
1 → enable pull high function

d) PAGE 2 (Counter5 Data Register)

Bit 7	Bit 6	Bit 5	Bit 4	Bit 3	Bit 2	Bit 1	Bit 0
CN57	CN56	CN55	CN54	CN53	CN52	CN51	CN50
R/W-0	R/W-0	R/W-0	R/W-0	R/W-0	R/W-0	R/W-0	R/W-0

Bit 0 ~ Bit 7 (CN50 ~ CN57) : Counter5 buffer that you can read and write.
Counter5 is an 8-bit up-counter with 8-bit prescaler that allows you to use RC PAGE2 to preset and read the counter (write → preset). After an interruption, it will reload the preset value.

7.2.14 RD (Interrupt Flag,)

a) PAGE 0 (Interrupt Flags Register)

Bit 7	Bit 6	Bit 5	Bit 4	Bit 3	Bit 2	Bit 1	Bit 0
-	-	-	-	-	CNT5	CNT4	CNT3
-	-	-	-	-	R/W-0	R/W-0	R/W-0

NOTE: "1" means interrupt request, "0" means non-interrupt

Bit 0 (CNT3) : Counter3 timer overflow interrupt flag. Set when counter3 timer overflows.

Bit 1 (CNT4) : Counter4 timer overflow interrupt flag. Set when counter4 timer overflows.

Bit 2 (CNT5) : Counter5 timer overflow interrupt flag. Set when counter5 timer overflows.



7.2.15 RE (Interrupt Flags, Wake-up)

a) PAGE 0 (Interrupt Flags, Wake-up Control Bits)

Bit 7	Bit 6	Bit 5	Bit 4	Bit 3	Bit 2	Bit 1	Bit 0
-	RBF	-	STB	/WUPC3	/WUPC2	/WUPC1	/WUPC0
-	R/W-0	R/W-0	R/W-0	R/W-0	R/W-0	R/W-0	R/W-0

- Bit 0 (/WUPC0) : PORTC0 wake-up control,
0/1 → disable/enable PC0 pin wake-up function
- Bit 1 (/WUPC1) : PORTC1 wake-up control, 0/1 → disable/enable PC1 pin wake-up function
- Bit 2 (/WUPC2) : PORTC2 wake-up control,
0/1 → disable/enable PC2 pin wake-up function
- Bit 3 (/WUPC3) : PORTC3 wake-up control,
0/1 → disable/enable PC3 pin wake-up function
- Bit 4(STB) : SPI data transfer start interrupt.
While the STB signal goes low, it will issue this interrupt.
- Bit 5 (-) : Not used
- Bit 6 (RBF) : SPI data transfer complete interrupt
If the SPI RBF signal contains a rising edge signal, CPU will set this bit (RBF set to "1" after data are completely transferred).
- Bit 7(-) : Not used

7.2.16 RF (Interrupt Flags)

a) PAGE 0 (Interrupt Status Register)

Bit 7	Bit 6	Bit 5	Bit 4	Bit 3	Bit 2	Bit 1	Bit 0
INT4	INT3	INT2	INT1	IR	CNT2	CNT1	TCIF
R/W-0	R/W-0	R/W-0	R/W-0	R/W-0	R/W-0	R/W-0	R/W-0

NOTE: "1" means interrupt request, "0" means non-interrupt

- Bit 0 (TCIF) : TCC timer overflow interrupt flag, Set when TCC timer overflows.
- Bit 1 (CNT1) : Counter1 timer overflow interrupt flag. Set when Counter1 timer overflows.
- Bit 2 (CNT2) : Counter2 timer overflow interrupt flag. Set when Counter2 timer overflows.
- Bit 3 (IR) : External INT pin interrupt flag. If PORT90 contains a falling /rising edge (controlled by CONT register) trigger signal, CPU will set this bit.
- Bit 4 (INT1) : External IR interrupt flag. If PORT91 contains a falling edge trigger signal, CPU will set this bit.
- Bit 5(INT2) : External INT2 pin interrupt flag. If PORT92 has a falling edge trigger signal, CPU will set this bit.
- Bit 6 : (INT3) : External INT3 pin interrupt flag. If PORT93 has a falling edge trigger signal, CPU will set this bit.
- Bit 7(INT4) : External INT1 pin interrupt flag, If PORT94 has a falling edge trigger signal, CPU will set this bit.

Trigger edge is as shown below:

Signal	Trigger
TCC	Time out
COUNTER1	Time out
COUNTER2	Time out
COUNTER3	Time out
COUNTER4	Time out
COUNTER5	Time out
IR	Falling Rising edge
INT1	Falling edge
INT2	Falling edge
INT3	Falling edge
INT4	Falling edge

7.2.17 R10~R3F (General Purpose Registers)

R10 ~ R1F, R20 ~ R3F (Banks 0 ~ 3) : all are general purpose registers.

7.3 Special Purpose Registers

7.3.1 A (Accumulator)

Internal data transfer, or instruction operand holding. It is not an addressable register.

7.3.2 CONT (Control Register)

CONT register is readable (CONTR) and writable (CONTW).

Bit 7	Bit 6	Bit 5	Bit 4	Bit 3	Bit 2	Bit 1	Bit 0
P90EG	INT	TS	RETBK	PAB	PSR2	PSR1	PSR0

Bit 0 ~ Bit 2 (PSR0 ~ PSR2) : TCC/WDT prescaler bits

PSR2	PSR1	PSR0	TCC Rate	WDT Rate
0	0	0	1:2	1:1
0	0	1	1:4	1:2
0	1	0	1:8	1:4
0	1	1	1:16	1:8
1	0	0	1:32	1:16
1	0	1	1:64	1:32
1	1	0	1:128	1:64
1	1	1	1:256	1:128

- Bit 3 (PAB) : Prescaler assignment bit
 0/1 → TCC/WDT
 When in WDT mode (Bit 3 = 1), the prescaler is cleared by the WDTC and SLEP instructions. Likewise, when in TCC mode (Bit 3 = 0), the prescaler will can NOT be cleared by SLEP instructions.
 An 8-bit counter is provided as prescaler for the TCC or WDT. The prescaler is available for the TCC only or for the WDT only at a given time. An 8 bit counter is made available for TCC or WDT as determined by the status of Bit 3 (PAB) of the CONT register.
 Both TCC and prescaler are cleared each time a write to TCC instruction is executed. (See the table above for the prescaler ratio under CONT register and Fig.7 below for the TCC/WDT block diagram.)
- Bit 4 (RETBK) : Return value backup control for interrupt routine
 0/1 → disable/enable
 When this bit is set to 1, the CPU will store ACC, R3 status, and R5 PAGE 1 automatically after an interrupt is triggered. It will be restored after instruction RETI. When this bit is set to 0, you need to store ACC, R3, and R5 PAGE 1 in you program.
- Bit 5 (TS) : TCC signal source
 0 → internal instruction cycle clock
 $\text{timing} = (2 / \text{system clock}) * \text{prescaler} * (256 - \text{count vaule})$
 1 → 16.384kHz
 $\text{timing} = (1 / 16.384\text{k}) * \text{prescaler} * (256 - \text{count vaule})$
- Bit 6 (INT) : INT enable flag
 0 → interrupt masked by DISI or hardware interrupt
 1 → interrupt enabled by ENI/RETI instructions
- Bit 7 (P90EG) : Interrupt edge type of P90
 0 → P90 interruption source is a rising edge signal.
 1 → P90 interruption source is a falling edge signal.

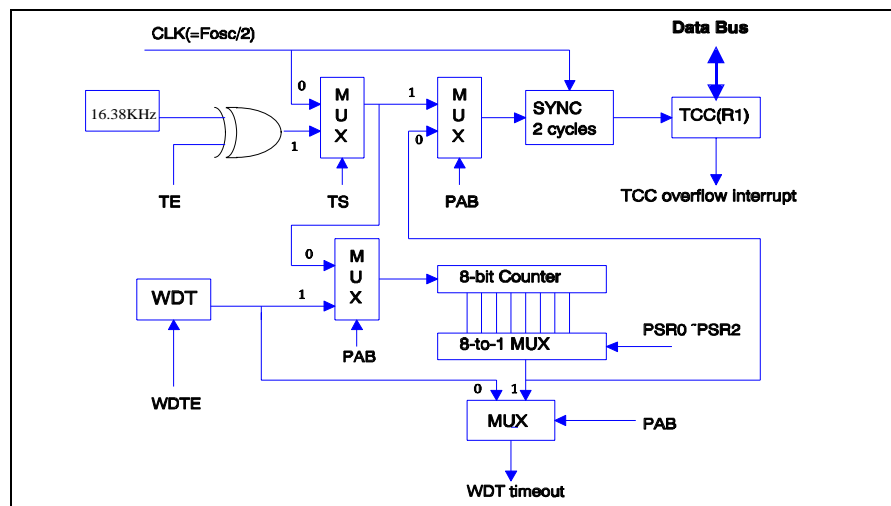

Fig. 7 TCC & WDT Block Diagram

7.3.3 IOC 5 (PORT5 Switches)

a) Page 1

Bit 7	Bit 6	Bit 5	Bit 4	Bit 3	Bit 2	Bit 1	Bit 0
P57S	P56S	P55S	P54S				
R/W-0	R/W-0	R/W-0	R/W-0				

Bit 4 ~ Bit 7 (P54S~P57S) : Port5 I/O direction control register

0 → set the relative I/O pin as output HV

1 → set the relative I/O pin into high impedance

7.3.4 IOC 8

a) PAGE 1 (Clock Source and Prescaler for COUNTER1 and COUNTER2)

Bit 7	Bit 6	Bit 5	Bit 4	Bit 3	Bit 2	Bit 1	Bit 0
CNT2S	C2_PSC2	C2_PSC1	C2_PSC0	CNT1S	C1_PSC2	C1_PSC1	C1_PSC0
R/W-0	R/W-0	R/W-0	R/W-0	R/W-0	R/W-0	R/W-0	R/W-0

Bit 0 ~ Bit 2 (C1_PSC0 ~ C1_PSC2) : COUNTER1 prescaler ratio

C1_PSC0	C1_PSC2	C1_PSC1	COUNTER1
0	0	0	1:2
1	0	0	1:4
0	0	1	1:8
1	0	1	1:16
0	1	0	1:32
1	1	0	1:64
0	1	1	1:128
1	1	1	1:256

Bit 3 (CNT1S) : COUNTER1 clock source

0 → 16.384kHz

timing = (1 / 16.384k) * prescaler * (256 – count vaule)

1 → system clock

timing = (2 / system clock) * prescaler* (256 – count vaule)

Bit 4 ~ Bit 6 (C2_PSC0 ~ C2_PSC2) : COUNTER2 prescaler ratio

C2_PSC2	C2_PSC1	C2_PSC0	COUNTER2
0	0	0	1:2
0	0	1	1:4
0	1	0	1:8
0	1	1	1:16
1	0	0	1:32
1	0	1	1:64
1	1	0	1:128
1	1	1	1:256



Bit 7 (CNT2S) : COUNTER2 clock source
 0 → 16.384kHz
 timing = (1 /16.384k) * prescaler * (256 – count vaule)
 1 → system clock
 timing = (2 / system clock) * prescaler* (256 – count vaule)

7.3.5 IOC9 (PORT9 I/O Control)

a) PAGE 0 (PORT9 I/O Control Register)

Bit 7	Bit 6	Bit 5	Bit 4	Bit 3	Bit 2	Bit 1	Bit 0
IOC97	IOC96	IOC95	IOC94	IOC93	IOC92	IOC91	IOC90
R/W-1	R/W-1	R/W-1	R/W-1	R/W-1	R/W-1	R/W-1	R/W-1

Bit 0 ~ Bit 7 (IOC90 ~ IOC97) : PORT9 (0~7) I/O direction control register
 0 → set the relative I/O pin as output
 1 → set the relative I/O pin into high impedance

b) PAGE 1 (Clock Source and Prescaler for COUNTER3 and COUNTER4)

Bit 7	Bit 6	Bit 5	Bit 4	Bit 3	Bit 2	Bit 1	Bit 0
CNT4S	C4_PSC2	C4_PSC1	C4_PSC0	CNT3S	C3_PSC2	C3_PSC1	C3_PSC0
R/W-0	R/W-0	R/W-0	R/W-0	R/W-0	R/W-0	R/W-0	R/W-0

Bit 0 ~ Bit 2 (C3_PSC0 ~ C3_PSC2) : COUNTER3 prescaler ratio

C3_PSC2	C3_PSC1	C3_PSC0	COUNTER3
0	0	0	1:2
0	0	1	1:4
0	1	0	1:8
0	1	1	1:16
1	0	0	1:32
1	0	1	1:64
1	1	0	1:128
1	1	1	1:256

Bit 3 (CNT3S) : COUNTER3 clock source
 0 → 16.384kHz
 timing = (1 /16.384k) * prescaler * (256 – count vaule)
 1 → system clock
 timing = (2 / system clock) * prescaler* (256 – count vaule)

Bit 4 ~ Bit 6 (C4_PSC0 ~ C4_PSC2) : COUNTER4 prescaler ratio

C4_PSC2	C4_PSC1	C4_PSC0	COUNTER4
0	0	0	1:2
0	0	1	1:4
0	1	0	1:8
0	1	1	1:16
1	0	0	1:32
1	0	1	1:64

1	1	0	1:128
1	1	1	1:256

Bit 7 (CNT4S) : COUNTER4 clock source

0 → 16.384kHz

timing = (1 /16.384k) * prescaler * (256 – count vaule)

1 → system clock

timing = (2 / system clock) * prescaler* (256 – count vaule)

7.3.6 IOCA

a) PAGE 1 (Clock Source and Prescaler for COUNTER5)

Bit 7	Bit 6	Bit 5	Bit 4	Bit 3	Bit 2	Bit 1	Bit 0
-	-	-	-	CNT5S	C5_PSC2	C5_PSC1	C5_PSC0
-	-	-	-	R/W-0	R/W-0	R/W-0	R/W-0

Bit 0 ~ Bit 2 (C5_PSC0 ~ C5_PSC2) : COUNTER5 prescaler ratio

C5_PSC2	C5_PSC1	C5_PSC0	COUNTER4
0	0	0	1:2
0	0	1	1:4
0	1	0	1:8
0	1	1	1:16
1	0	0	1:32
1	0	1	1:64
1	1	0	1:128
1	1	1	1:256

Bit 3 (CNT5S) : COUNTER5 clock source

0 → 16.384kHz

timing = (1 /16.384k) * prescaler * (256 – count vaule)

1 → system clock

timing = (2 / system clock) * prescaler* (256 – count vaule)

7.3.7 IOCC (PORTC I/O Control)

a) PAGE 0 (PORTC I/O Control Register)

Bit 7	Bit 6	Bit 5	Bit 4	Bit 3	Bit 2	Bit 1	Bit 0
IOCC7	IOCC6	IOCC5	IOCC4	IOCC3	IOCC2	IOCC1	IOCC0
R/W-1	R/W-1	R/W-1	R/W-1	R/W-1	R/W-1	R/W-1	R/W-1

Bit 0 ~ Bit 7 (IOCC0 ~ IOCC7) : PORTC(0~7) I/O direction control register

0 → set the relative I/O pin as output

1 → set the relative I/O pin into high impedance



b) PAGE 1 (PORTC Switches)

Bit 7	Bit 6	Bit 5	Bit 4	Bit 3	Bit 2	Bit 1	Bit 0
PC7S	PC6S	PC5S	PC4S	-	-	-	-
R/W-1	R/W-1	R/W-1	R/W-1	-	-	-	-

Bit 4 (PC4S) : Select STB or I/O PORTC4 pin
 0 → PC4 (I/O PORTC4) pin is selected
 1 → STB pin is selected

Bit 5 (PC5S) : Select CLK or I/O PORTC5 pin
 0 → PC5 (I/O PORTC5) pin is selected
 1 → CLK pin is selected

Bit 6 (PC6S) : Select DOUT or I/O PORTC6 pin
 0 → PC6 (I/O PORTC6) pin is selected
 1 → DOUT pin is selected (N-channel,Open-Drain)

Bit 7 (PC7S) : Select DIN or I/O PORTC7 pin
 0 → PC7 (I/O PORTC7) pin is selected
 1 → DIN pin is selected

7.3.8 IOCD (Interrupt Mask, Prescaler of CN3 ~ CN5)

a) PAGE 0 (Interrupt Mask)

Bit 7	Bit 6	Bit 5	Bit 4	Bit 3	Bit 2	Bit 1	Bit 0
-	-	-	-	-	CNT5	CNT4	CNT3
-	-	-	-	-	R/W-0	R/W-0	R/W-0

Bit 0 ~ 3 : Interrupt enable bit
 0 → disable interrupt
 1 → enable interrupt

7.3.9 IOCE (Interrupt Mask)

a) PAGE 0 (Interrupt Mask)

Bit 7	Bit 6	Bit 5	Bit 4	Bit 3	Bit 2	Bit 1	Bit 0
-	RBF	-	STB	-	-	-	-
-	R/W-0	-	R/W-0	-	-	-	-

Bit 4 (STB) : STB goes LOW interrupt mask.
 0/1 → disable/enable interrupt

Bit 6 (RBF) : SPI's RBF interrupt mask
 0/1 → disable/enable interrupt

7.3.10 IOCF (Interrupt Mask)

a) PAGE 0 (Interrupt Mask Register)

Bit 7	Bit 6	Bit 5	Bit 4	Bit 3	Bit 2	Bit 1	Bit 0
INT4	INT3	INT2	INT1	IR	CNT2	CNT1	TCIF
R/W-0	R/W-0	R/W-0	R/W-0	R/W-0	R/W-0	R/W-0	R/W-0



Bit 0 ~ 7: Interrupt enable bit
 0 → disable interrupt
 1 → enable interrupt

The status after interrupt and the interrupt source lists are as shown in the table below.

Interrupt Signal	IDLE Mode	GREEN Mode	NORMAL Mode
	RA(7,6)=(1,0) + SLEP	RA(7,6)=(x,0) no SLEP	RA(7,6)=(x,1) no SLEP
TCC time out IOCF bit0=1 And "ENI"	1) Wake-up 2) Interrupt (jump to Address 8 on Page0) 3) After RETI instruction, jump to SLEP Next instruction	Interrupt (jump to Address 8 on Page0)	Interrupt (jump to Address 8 on Page0)
COUNTER1 time out IOCF bit1=1 And "ENI"	1) Wake-up 2) Interrupt (jump to Address 8 on Page0) 3) After RETI instruction, jump to SLEP Next instruction	Interrupt (jump to Address 8 on Page0)	Interrupt (jump to Address 8 on Page0)
COUNTER2 time out IOCF bit2=2 And "ENI"	1) Wake-up 2) Interrupt (jump to Address 8 on Page0) 3) After RETI instruction, jump to SLEP Next instruction	Interrupt (jump to Address 8 on Page0)	Interrupt (jump to Address 8 on Page0)
COUNTER3 time out IOCD bit0=1 And "ENI"	1) Wake-up 2) Interrupt (jump to Address 8 on Page0) 3) After RETI instruction, jump to SLEP Next instruction	Interrupt (jump to Address 8 on Page0)	Interrupt (jump to Address 8 on Page0)
COUNTER4 time out IOCD bit1=1 And "ENI"	1) Wake-up 2) Interrupt (jump to Address 8 on Page0) 3) After RETI instruction, jump to SLEP Next instruction	Interrupt (jump to Address 8 on Page0)	Interrupt (jump to Address 8 on Page0)
COUNTER5 time out IOCD bit2=1 And "ENI"	1) Wake-up 2) Interrupt (jump to Address 8 on Page0) 3) After RETI instruction, jump to SLEP Next instruction	Interrupt (jump to Address 8 on Page0)	Interrupt (jump to Address 8 on Page0)
INT1~4 IOCF bit4=1 or IOCF bit5=1 IOCF bit6 = 1 or IOCF bit7= 1 And "ENI"	1) Wake-up 2)Interrupt (jump to Address 8 on Page0) 3) after RETI instruction, jump to SLEP Next instruction	Interrupt (jump to Address 8 on Page0)	Interrupt (jump to Address 8 on Page0)
IR IOCF bit3= 1 And "ENI"	1) Wake-up 2) Interrupt (jump to Address 8 on Page0) 3) After RETI instruction, jump to SLEP Next instruction	Interrupt (jump to Address 8 on Page0)	Interrupt (jump to Address 8 on Page0)



RBF IOCE bit6 = 1 And "ENI	No function	Interrupt (jump to Address 8 on Page0)	Interrupt (jump to Address 8 on Page0)
STB IOCE bit4 = 1 And "ENI	No function	Interrupt (jump to Address 8 on Page0)	Interrupt (jump to Address 8 on Page0)

- NOTES:**
- 1. PORT90 interrupt function is controlled by IOCF Bit 3. It is a falling edge or rising edge trigger (controlled by CONT register Bit7).*
 - 2. PORT9 (1~4) interrupt functions are controlled by IOCF Bits 4, 5, 6, & 7). They are falling edge triggers.*
 - 3. STB interrupt source function is controlled by IOCE PAGE0 Bit 4. It is falling edge trigger after the STB goes low.*

7.4 Application notes

1、 Call-table instruction: :

Because the call-table instruction can only change the Program Counter's bit7 ~ bit0 at each time, only 256 addresses can be searched once. But each program page contains 1024 addresses, if call each 256 addresses as a zone, Then each page constitutes by four zones. When a table overlaps two zones, a bug would occur during address searching. So the member of program must examine the .LST file at any time, the .LST file will jot down the information that Assembler generated, for example source code, the coding of instruction , instruction address, error message etc.

2、 Operation requirement for the CPU :

The system frequency must adds a latency time (14.33 MHz about 250 ms ; 17.91 MHz about 450 ms.). After RA register was setting, it will offer the stable system frequency for the operation.

3、 The register initial sets to suggest

The register 0X0B of IOC page 0 & page 1 initial sets suggestion as follows
 0x0B register value = 0x00
 The register 0X0B of R page 0 initial sets suggestion as follows
 0x0B register value = 0x00

7.5 I/O Port

The I/O registers are bi-directional tri-state I/O ports. The I/O ports can be defined as "input" or "output" pins by the I/O control registers under program control. The I/O data registers and I/O control registers are both readable and writable. The I/O interface circuit is shown in Fig.22.

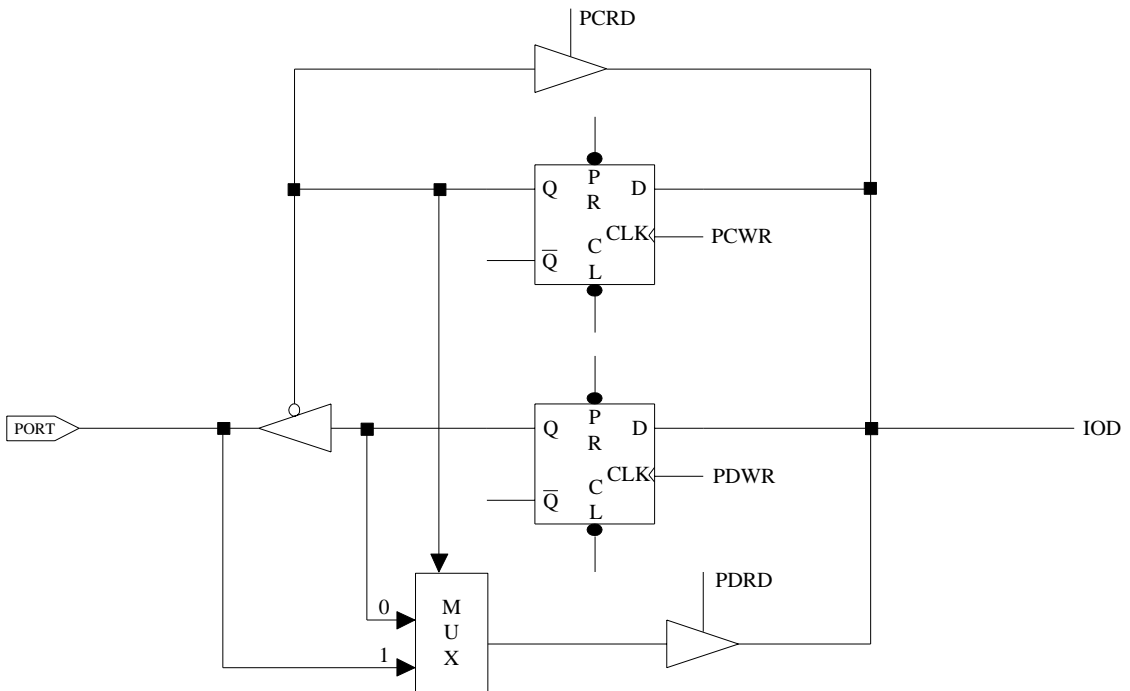

Fig. 8 The Circuit of I/O Port and I/O Control Register

7.6 RESET

A RESET can be caused by any of the following:

1. Power on reset
2. WDT timeout (if enabled and in GREEN or NORMAL mode)
3. /RESET pin pull low

Once a RESET occurs, the following functions are performed.

- The oscillator is running, or will be started.
- The Program Counter (R2) is set to all "0".
- When power on, the upper 3 bits of R3 and the upper 2 bits of R4 are cleared.
- The Watchdog timer and prescaler counter are cleared.
- The Watchdog timer is disabled.
- The CONT register is set to all "1"



- The other registers' (Bit 7 ~ Bit 0) default values are as follows.

Address	R Register PAGE 0	R Register PAGE 1	R Register PAGE 2	R Register PAGE 3	IOC Register PAGE 0	IOC Register PAGE 1
0x4	00xxxxxx					
0x5	0000xxxx	xxxx0000	00000000			
0x6	00000000		xxxxxxx			
0x7	00000000	00000000	xxxxxxx			
0x8	00000000	00000000	xxxxxxx			00000000
0x9	00000000	xxxxxxx	xxxxxxx		11111111	00000000
0xA	00011xx0	xxxxxxx	xxxxxxx			00000000
0xB	00000000	00000000	xxxxxxx		00000000	x0000000
0xC	1011xxxx	00000000	xxxxxxx		1111xxxx	1111xxxx
0xD	xxxxx000				xxxxx000	
0xE	X0000000				x000xxxx	
0xF	00000000				00000000	

7.7 Wake Up

The controller features two types of sleep mode for power saving:

7.7.1 SLEEP Mode, RA(6 ;7) = 0 + "SLEP" Instruction

Under this mode, the controller turns off all the CPU and crystal. However, other circuits with power control like key tone control or PLL control (with register enabled), has to be turned off through software.

7.7.2 IDLE mode, RA(6 ;7) = 1 + "SLEP" Instruction.

With this mode, the controller only turns the CPU off. The crystal remains running.

7.7.3 Wake-up from SLEEP Mode

1. WDT time out
2. External interrupt
3. /RESET pull low

Any of these cases will reset the controller and run the program from address zero. The status is just like the power-on-reset condition. Be sure to enable circuit after cases 1 or 2 occurs.



7.7.4 Wake-up from IDLE Mode

1. WDT time out
2. External interrupt
3. Internal interrupt like counters

All these cases requires you to enable the circuit before entering IDLE mode. All the registers values are preserved when "SLEP" instruction is executed and restored after wake-up.

During execution of case 2 or 3, controller will wake up and jump to address 0x08 for interruption sub-routine. After performing the sub-routine ("RETI" instruction), the program will jump to the next instruction following the "SLEP" instruction.

7.8 Interrupts

RD, RE, and RF are the interrupt status registers which record the interrupt request in flag bit. IOCD, IOCE, & IOCF are their interrupt mask registers respectively. Global interrupt is enabled by ENI instruction and is disabled by DISI instruction. When one of the interrupts (when enabled) is generated, it will cause the next instruction to be fetched from address 008H. Once in the interrupt service routine, the source of the interrupt can be determined by polling the flag bits in their respective (RD, RE, and RF) registers.

The interrupt flag bit must be cleared in the software before leaving the interrupt service routine and enabling interrupts to avoid recursive interrupts.

7.9 Instruction Set

The Instruction set has the following features:

1. Every bit of any register can be set, cleared, or tested directly.
2. The I/O register can be treated as a general register. That is, the same instruction can operates on I/O register.

The symbol "R" represents a register designator which specifies which one of the 64 registers (including operational registers and general purpose registers) is to be utilized by the instruction. Bits 6 and 7 in R4 determine the selected register bank. "b" represents a bit field designator which selects the number of the bit located in the Register "R," and affected by the operation. "k" represents an 8 or 10-bit constant or literal value.



Instruction Binary	HEX	Mnemonic	Operation	Status Affected	Instruction Cycle
0 0000 0000 0000	0000	NOP	No Operation	None	1
0 0000 0000 0001	0001	DAA	Decimal Adjust A	C	1
0 0000 0000 0010	0002	CONTW	A → CONT	None	1
0 0000 0000 0011	0003	SLEP	0 → WDT, Stop oscillator	T,P	1
0 0000 0000 0100	0004	WDTC	0 → WDT	T,P	1
0 0000 0000 rrrr	000r	IOW R	A → IOCR	None	1
0 0000 0001 0000	0010	ENI	Enable Interrupt	None	1
0 0000 0001 0001	0011	DISI	Disable Interrupt	None	1
0 0000 0001 0010	0012	RET	[Top of Stack] → PC	None	2
0 0000 0001 0011	0013	RETI	[Top of Stack] → PC Enable Interrupt	None	2
0 0000 0001 0100	0014	CONTR	CONT → A	None	1
0 0000 0001 rrrr	001r	IOR R	IOCR → A	None	1
0 0000 0010 0000	0020	TBL	R2+A → R2 bits 9,10 do not clear	Z,C,DC	2
0 0000 01rr rrrr	00rr	MOV R,A	A → R	None	1
0 0000 1000 0000	0080	CLRA	0 → A	Z	1
0 0000 11rr rrrr	00rr	CLR R	0 → R	Z	1
0 0001 00rr rrrr	01rr	SUB A,R	R-A → A	Z,C,DC	1
0 0001 01rr rrrr	01rr	SUB R,A	R-A → R	Z,C,DC	1
0 0001 10rr rrrr	01rr	DECA R	R-1 → A	Z	1
0 0001 11rr rrrr	01rr	DEC R	R-1 → R	Z	1
0 0010 00rr rrrr	02rr	OR A,R	A ∨ R → A	Z	1
0 0010 01rr rrrr	02rr	OR R,A	A ∨ R → R	Z	1
0 0010 10rr rrrr	02rr	AND A,R	A & R → A	Z	1
0 0010 11rr rrrr	02rr	AND R,A	A & R → R	Z	1
0 0011 00rr rrrr	03rr	XOR A,R	A ⊕ R → A	Z	1
0 0011 01rr rrrr	03rr	XOR R,A	A ⊕ R → R	Z	1
0 0011 10rr rrrr	03rr	ADD A,R	A + R → A	Z,C,DC	1
0 0011 11rr rrrr	03rr	ADD R,A	A + R → R	Z,C,DC	1
0 0100 00rr rrrr	04rr	MOV A,R	R → A	Z	1
0 0100 01rr rrrr	04rr	MOV R,R	R → R	Z	1
0 0100 10rr rrrr	04rr	COMA R	/R → A	Z	1
0 0100 11rr rrrr	04rr	COM R	/R → R	Z	1
0 0101 00rr rrrr	05rr	INCA R	R+1 → A	Z	1
0 0101 01rr rrrr	05rr	INC R	R+1 → R	Z	1
0 0101 10rr rrrr	05rr	DJZA R	R-1 → A, skip if zero	None	2 if skip
0 0101 11rr rrrr	05rr	DJZ R	R-1 → R, skip if zero	None	2 if skip
0 0110 00rr rrrr	06rr	RRCA R	R(n) → A(n-1) R(0) → C, C → A(7)	C	1



0 0110 01rr rrrr	06rr	RRC R	$R(n) \rightarrow R(n-1)$ $R(0) \rightarrow C, C \rightarrow R(7)$	C	1
0 0110 10rr rrrr	06rr	RLCA R	$R(n) \rightarrow A(n+1)$ $R(7) \rightarrow C, C \rightarrow A(0)$	C	1
0 0110 11rr rrrr	06rr	RLC R	$R(n) \rightarrow R(n+1)$ $R(7) \rightarrow C, C \rightarrow R(0)$	C	1
0 0111 00rr rrrr	07rr	SWAPA R	$R(0-3) \rightarrow A(4-7)$ $R(4-7) \rightarrow A(0-3)$	None	1
0 0111 01rr rrrr	07rr	SWAP R	$R(0-3) \leftrightarrow R(4-7)$	None	1
0 0111 10rr rrrr	07rr	JZA R	$R+1 \rightarrow A$, skip if zero	None	2 if skip
0 0111 11rr rrrr	07rr	JZ R	$R+1 \rightarrow R$, skip if zero	None	2 if skip
0 100b bbrr rrrr	0xxx	BC R,b	$0 \rightarrow R(b)$	None	1
0 101b bbrr rrrr	0xxx	BS R,b	$1 \rightarrow R(b)$	None	1
0 110b bbrr rrrr	0xxx	JBC R,b	if $R(b)=0$, skip	None	2 if skip
0 111b bbrr rrrr	0xxx	JBS R,b	if $R(b)=1$, skip	None	2 if skip
1 00kk kkkk kkkk	1kkk	CALL k	$PC+1 \rightarrow [SP]$ $(Page, k) \rightarrow PC$	None	2
1 01kk kkkk kkkk	1kkk	JMP k	$(Page, k) \rightarrow PC$	None	2
1 1000 kkkk kkkk	18kk	MOV A,k	$k \rightarrow A$	None	1
1 1001 kkkk kkkk	19kk	OR A,k	$A \vee k \rightarrow A$	Z	1
1 1010 kkkk kkkk	1Akk	AND A,k	$A \& k \rightarrow A$	Z	1
1 1011 kkkk kkkk	1Bkk	XOR A,k	$A \oplus k \rightarrow A$	Z	1
1 1100 kkkk kkkk	1Ckk	RETL k	$k \rightarrow A, [Top\ of\ Stack] \rightarrow PC$	None	2
1 1101 kkkk kkkk	1Dkk	SUB A,k	$k-A \rightarrow A$	Z,C,DC	1
1 1110 0000 0001	1E01	INT	$PC+1 \rightarrow [SP]$ $001H \rightarrow PC$	None	1
1 1110 100k kkkk	1E8k	PAGE k	$K \rightarrow R5(4:0)$	None	1
1 1111 kkkk kkkk	1Fkk	ADD A,k	$k+A \rightarrow A$	Z,C,DC	1



8 Segment Data Buffers

The ePVP6200 chip provides a total of 256 bytes data RAM. On the other hand, display Segment Data Buffers can be stored either in the data RAM of 256 bytes sizes (00h~40h) or in the common registers of Bank 2 and Bank 3 (20h~3Fh).

a) Data RAM Address

00h~38h	57X8 Segment Data Buffers
39h~3Eh	6X8 Key Scanning Data Buffers
3Fh	SW data register
40h	LED data register

b) Common Registers Address

20	Bank0~Bank3
:	Common registers
3F	(32x8 for each bank)

These buffers store display RAM. The display RAM stores the data transmitted from an external device to the ePVP6200 through the serial interface and is assigned addresses as follows, in units of 8 bits:

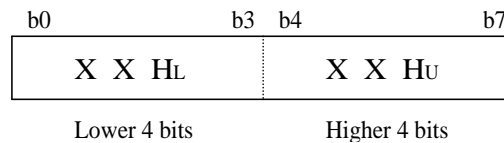

Only the lower 4 bits of the addresses assigned to SEG17 through SEG20 are valid and the higher 4 bits are ignored.

c) Display Memory Addresses:

Seg1	Seg4	Seg8	Seg12	Seg16	Seg20	
00 HL		00 HU	01 HL	01 HU	02 HL	DIG1
03 HL		03 HU	04 HL	04 HU	05 HL	DIG2
06 HL		06 HU	07 HL	07 HU	08 HL	DIG3
09 HL		09 HU	0A HL	0A HU	0B HL	DIG4
0C HL		0C HU	0D HL	0D HU	0E HL	DIG5
0F HL		0F HU	10 HL	10 HU	11 HL	DIG6
12 HL		12 HU	13 HL	13 HU	14 HL	DIG7
15 HL		15 HU	16 HL	16 HU	17 HL	DIG8
18 HL		18 HU	19 HL	19 HU	1A HL	DIG9
1B HL		1B HU	1C HL	1C HU	1D HL	DIG10
1E HL		1E HU	1F HL	1F HU	20 HL	DIG11
21 HL		21 HU	22 HL	22 HU	23 HL	DIG12
24 HL		24 HU	25 HL	25 HU	26 HL	DIG13

27 HL	27 HU	28 HL	28 HU	29 HL	DIG14
2A HL	2A HU	2B HL	2B HU	2C HL	DIG15
2D HL	2D HU	2E HL	2E HU	2F HL	DIG16
30 HL	30 HU	31 HL	31 HU	32 HL	DIG17
33 HL	33 HU	34 HL	34 HU	35 HL	DIG18
36 HL	36 HU	37 HL	37 HU	38 HL	DIG19

b) Key Scanning Data Buffers:

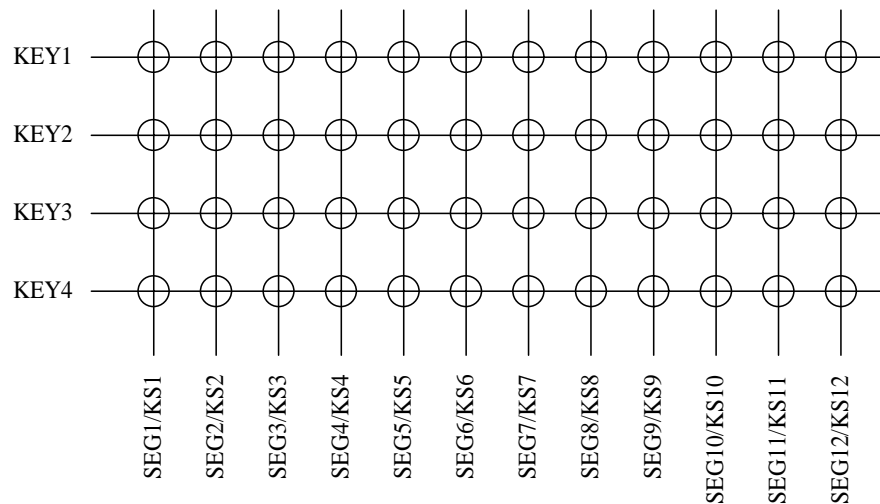
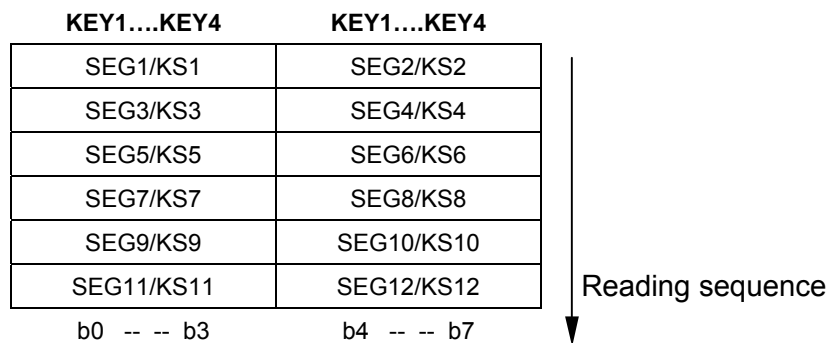

Fig. 10 12 x 4 Configuration Key Matrix

The key matrix is of 12 x 4 configuration is as shown in the above figure.

The data of each key is stored as illustrated below, and is read by a read command, starting from the least significant bit.



When the most significant bit of data (SEG12, b7) has been read, the least significant bit of the next data (SEG1, b0) is read.

8.1 Commands

A command sets the display mode and status of the VFD driver.



The first 1 byte (b0 to b7) inputted to the ePVP6200 through the DIN pin after the STB pin has fallen, is regarded as a command. Interrupt event will occur when STB pin is falling.

If STB mode is high while a command/data are being transmitted, serial communication is initialized, and the command/data being transmitted is invalidated (however, the command/data already transmitted remain valid).

8.1.1 Display Mode Setting Command [00]

This command initializes the ePVP6200 and selects Display mode number of segments and grids (1/8 to 1/19-duty, 9 segments to 20 segments) as illustrated below.

When Display Mode command is executed, display is forcibly turned off, and key scanning is also stopped. To resume display, a display ON command must be executed. If the same Display mode is selected, nothing is performed.

When power is turned "ON," default Display mode is "19-digit, 9-segment."

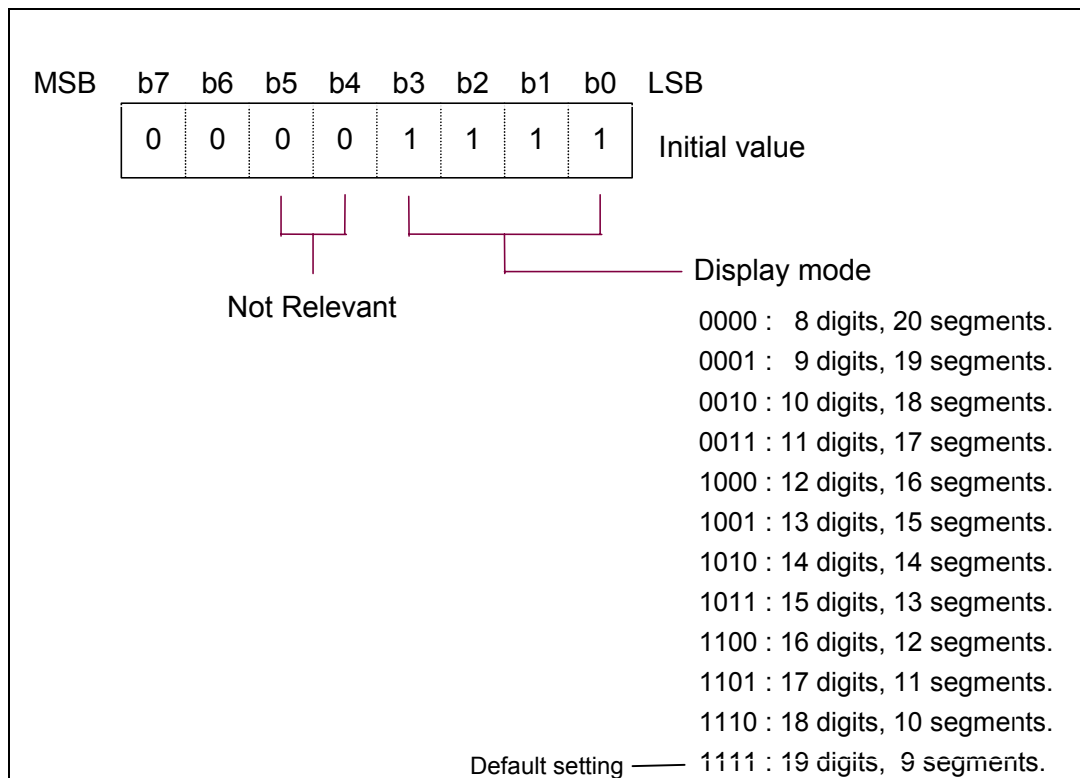

Fig. 11 Display Mode Setting Command Selection

8.1.2 Data Setting Command [01]

This command sets data write and data read modes. The default settings at power “ON” are:

- Address Increment Mode: “Address increment mode.”
- Test Mode: “Normal operation mode.”

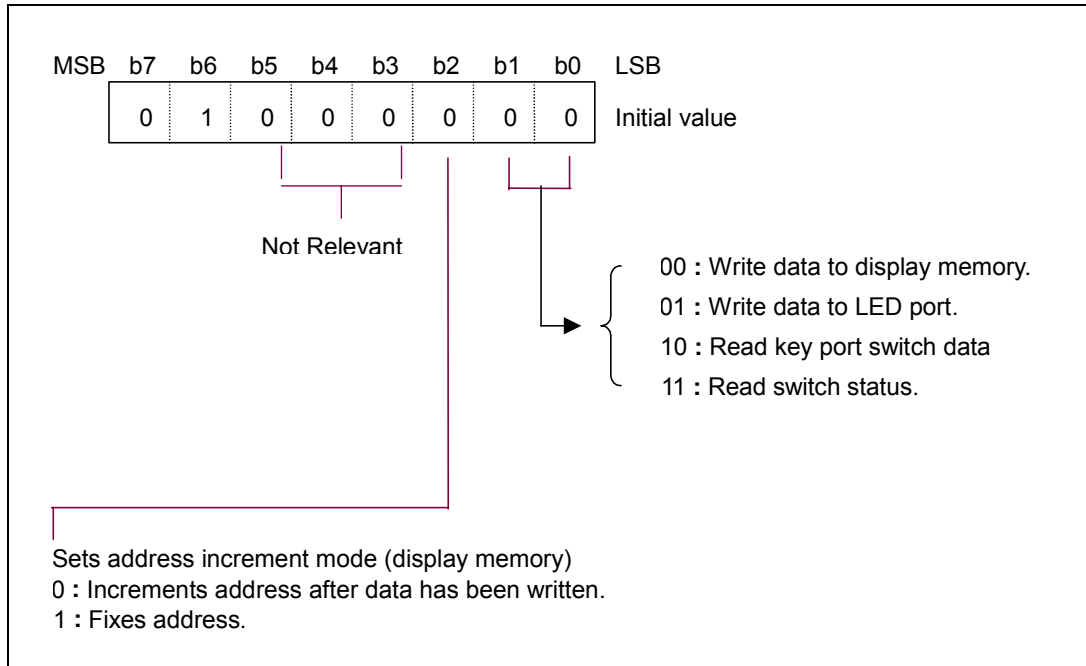

Fig. 12 Data Setting Command Selection

8.1.3 Display Control Command [10]

When power is turned "ON," the following default conditions prevails:

- 4/64-pulse width is set and the display is turned off
- Key & switch scanning is stopped

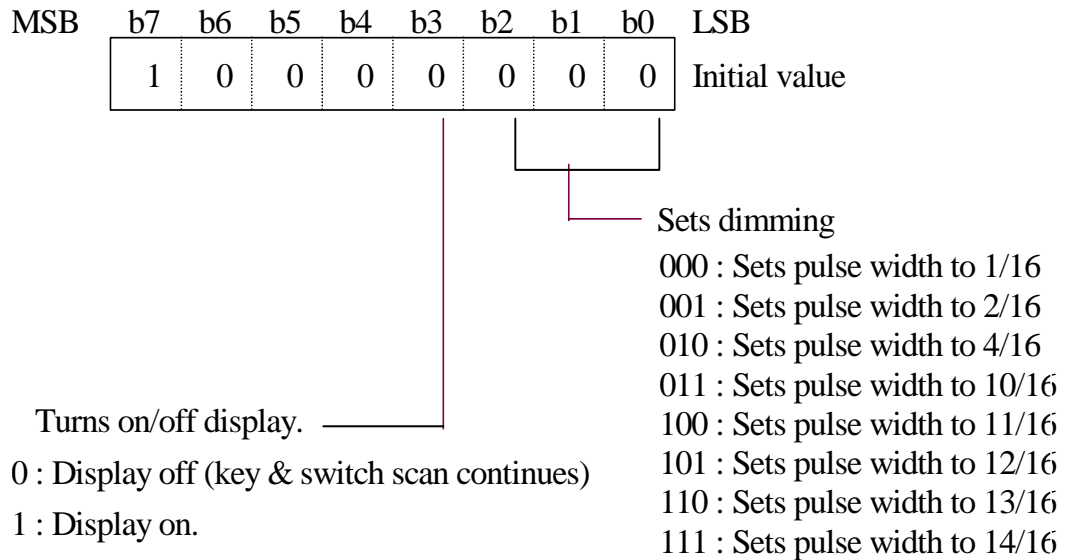

Fig. 13 Display Control Command Selection

8.1.4 Address Setting Command [11]

This command sets an address of the display memory. When power is turned "ON", the default address is set to 00H.

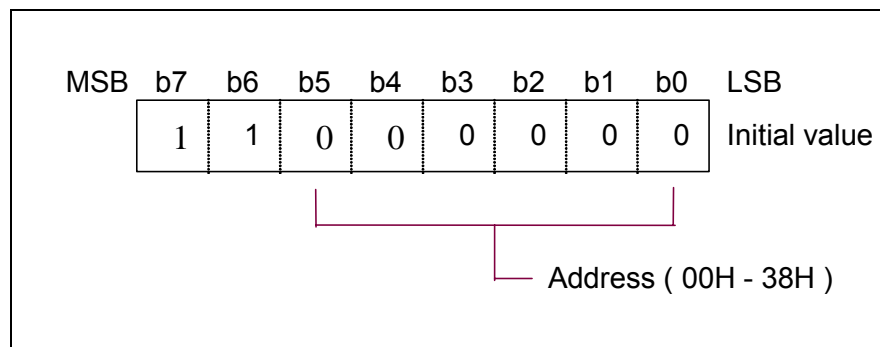

Fig. 14 Address Setting Command Selection

If address 39H or higher is set, the data is ignored until a correct address is set.

9 Crystal OSC

9.1 General Description

This oscillator is designed for the ePVP6200 chip as clock source.

9.2 Features

- Crystal oscillator: 32.768K Hz
- Operating voltage: 2.2~5.5V.
- Operating temperature: -20 °C ~ 70 °C

9.3 Block Diagram

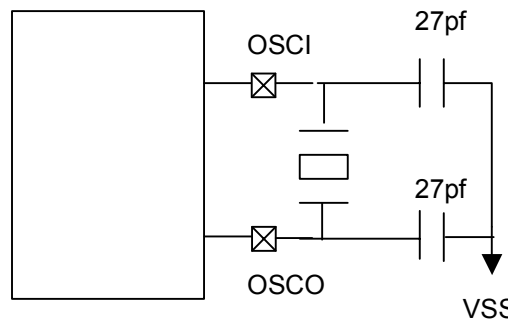

Fig. 15 Crystal OSC Block Diagram

9.4 Pin Description

Name	I/O Type	Description	Remarks
OSCI	I	Crystal oscillator connection pin	
OSCO	O	Crystal oscillator output pin	
VDD	-	Power supply (+) pin	
VSS	-	Power supply (-) pin	

9.5 Electrical

(Condition : VDD = 4.5 to 5.5V, Ta = -20°C to 70°C)

Parameters	Sym.	Min.	Typ.	Max.	Unit	Conditions
Starting oscillation voltage	Vs	-	2.0	3.2	V	
Stable time	Ts	-	5	10	clk	Vdd = 5.0V
Current consumption	Idd	-	2	3	mA	Vdd = 5.0V
Duty cycle		45	50	55	%	
Frequency/Voltage deviation	$\partial f/\partial V$	-	1	1.5	%	
Frequency/Temperature deviation	Δf	-	1	2	%	
Frequency vs. Process deviation		-	± 6	± 10	%	



10 Absolute Operation Maximum Ratings

Absolute maximum ratings (Ta = 25°C, Vss = 0 V)

Parameter	Symbol	Ratings	Unit
Logic supply voltage	V _{DD}	-0.5 to + 6	V
Driver supply voltage	V _{EE}	VDD +0.5 to VDD - 45	V
Logic input voltage	V _I	-0.5 to VDD +0.5	V
VFD driver output voltage	V _O	VEE -0.5 to VDD +0.5	V
LED driver output current	I _{O1}	+25	mA
VFD driver output current	I _{O2}	-40 (Grid) -15 (Segment)	mA
Operating ambient temperature	T _{opt}	-40 to +85	°C
Storage temperature	T _{stg}	-65 to +150	°C

11 DC Electrical Characteristic

(Ta = -20 to +70°C, VDD = 4.5 to 5.5V, Vss = 0V, VEE = VDD - 45V)

Parameter	Symbol	Min.	Typ.	Max.	Unit	Test conditions
Schmitt Trigger Negative Going Threshold Voltage	V _{T-}	1.5	1.8	2.1		GPIOC, GPO9, CLK, STB, DIN and /RESET
Schmitt Trigger Positive Going Threshold Voltage	V _{T+}	2.9	3.2	3.5	V	
Input Leakage Current	I _{IN}	-	-	±1	uA	V _{IN} = V _{DD} or V _{SS}
Pull Up Resister	R _{PU}	50	75	100	K	GPIOC, GPO9, CLK, STB, DOUT, DIN , CRYXRC and /RESET @ VDD=5V
Digital Output Voltage High	V _{OH}	0.8V _{DD}	-	V _{DD}	V	DOUT, GPIOC
Digital Output Voltage Low	V _{OL}	V _{SS}	-	0.2V _{DD}	V	
Digital Output High Current	I _{OH1}	-2	-4	-5	mA	V _{OH} =2.4V / DOUT, GPIOC
Digital Output Low Current	I _{OL1}	2	4	5	mA	V _{OL} =0.4V / DOUT, GPIOC
Digital Output High Current	I _{OH2}	-15	-18	-25	mA	V _{OH} =2.4V / GPIO9
Digital Output Low Current	I _{OL2}	15	18	25	mA	V _{OL} =0.4V / GPIO9
HV Output Current	I _{OH1}	-6	-5	-3	mA	V _O = VDD -2V,(VDD=5V) SEG1/KS1 to SEG4/KS4, SG5/KS5 to SG9/KS9.
HV Output Current	I _{OH2}	-15	-14	-11	mA	V _O = VDD -2V,(VDD=5V) GR1 to GR8 GR9/SG20 to GR16/SG13, GR17/SG12/KS12 to GR19 /SG10/KS10
HV leakage current	I _{HVLEAK}	5	8	10	uA	V _O = VDD -45V, driver off



HV Output pull-down resistor	R_L	40	80	120	K Ω	Driver output (VEE= -25V)
Power down current (SLEEP mode) Crystal oscillation operating mode	I_{SB1}		-	1.5	μA	VDD =5V ,All input and I/O pin at VDD, output pin floating, WDT disabled
Low clock current (GREEN mode) Crystal oscillation operating mode	I_{SB2}		30	60	μA	VDD =3V CLK=32.768KHz, all analog circuits disabled, all input and I/O pin at VDD, output pin floating
			65	90	μA	VDD =5V CLK=32.768KHz, all analog circuits disabled, all input and I/O pin at VDD, output pin floating
Low clock current (IDLE mode) Crystal oscillation operating mode	I_{SB3}		30	45	μA	VDD =3V CLK=32.768KHz, all analog circuits disabled, all input and I/O pin at VDD, output pin floating
			45	60	μA	VDD =5V CLK=32.768KHz, all analog circuits disabled, all input and I/O pin at VDD, output pin floating
Operating supply current (Normal mode) Crystal oscillation operating mode	I_{CC}		1.3	2	mA	/RESET=High, CLK=3.582MHz, all analog circuits disabled, output pin floating

12 AC Electrical Characteristic

12.1 CPU Instruction Timing (Ta = -20°C ~ 70°C, VDD=5V, VSS=0V)

Parameter	Symbol	Condition	Min	Typ	Max	Unit
Input CLK duty cycle	Dclk		45	50	55	%
Instruction cycle time	Tins	32.768kHz		60		us
		3.582MHz		550		ns
Device delay hold time	Tdrh			16		ms
TCC input period	Ttcc	Note 1	(Tins+20)/N			ns
Watchdog timer period	Twdt	Ta = 25°C		16		ms

NOTE: N= selected prescaler ratio

12.2 AC Timing Characteristic (VDD=5V, Ta=+25°C)

Description	Symbol	Min	Typ	Max	Unit
Oscillator timing characteristic					
OSC start up	32.768kHz	Tosc	400		1500 ms
	3.579MHz PLL			5	10 us
SPI timing characteristic (CPU clock 3.58MHz and Fsc0 = 3.582Mhz /2)					
/SS set-up time	Tcss	560			ns
/SS hold time	Tcsh	250			
SCLK high time	Thi	250			ns
SCLK low time	Tlo	250			ns
SCLK rising time	Tr		15	30	ns
SCLK falling time	Tf		15	30	ns
SDI set-up time to the reading edge of SCLK	Tisu	25			ns
SDI hold time to the reading edge of SCLK	Tihd	25			ns
SDO disable time	Tdis			560	ns

12.3 ePVP6200 Operating Voltage VS main clock

(X Axis → Min VDD ; Y Axis → Main CLK)

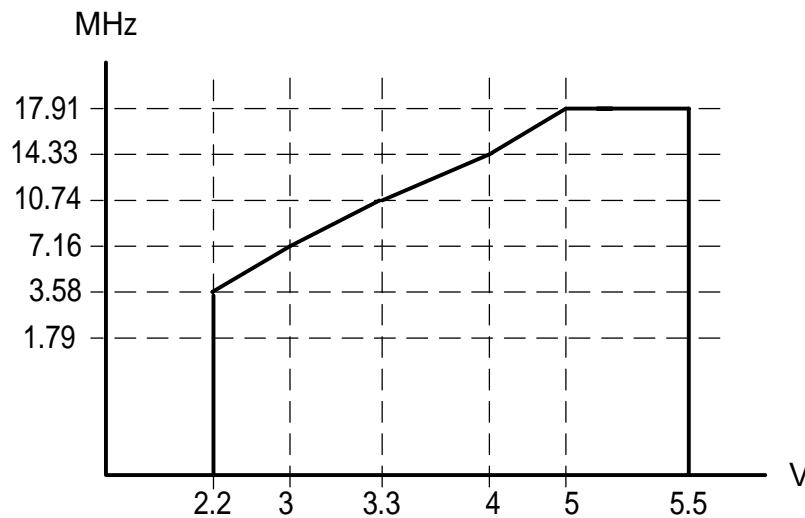
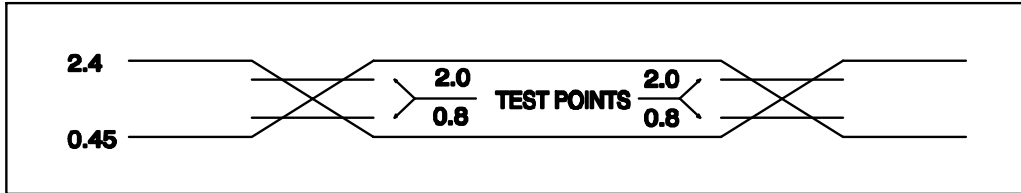

Fig. 16 Operation Voltage XY Axis

12.4 AC Timing Diagrams

AC Test Input/Output Waveform



AC Testing: Input are driven at 2.4V for logic "1", and 0.45V for logic "0". Timing measurements are made at 2.0V for logic "1", and 0.8V for logic "0".

Fig. 17a A/C Test Input/Output Waveform

RESET Timing

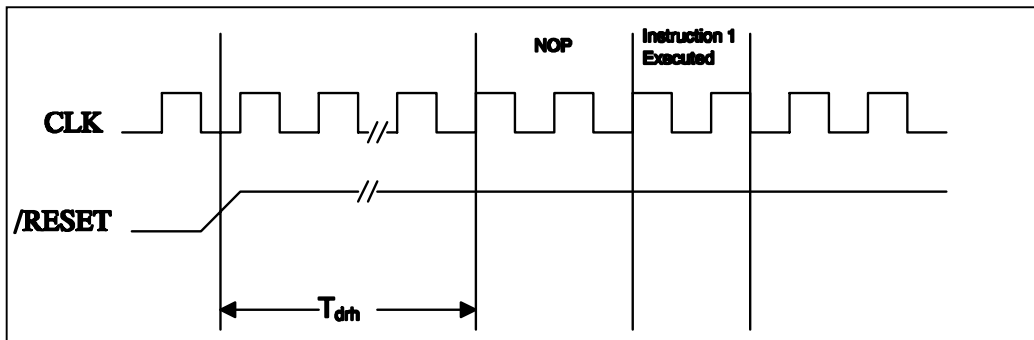

Fig. 17b RESET Timing Diagram

TCC Input Timing

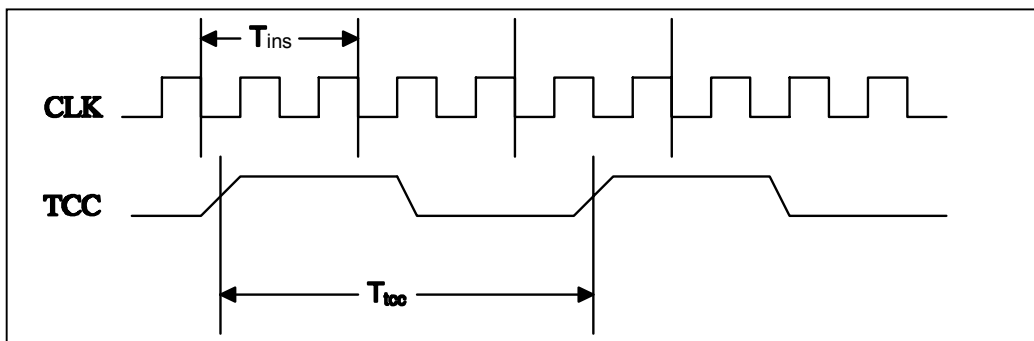

Fig. 17c TCC Input Timing Diagram

13 Key & Switch Scanning and Display Timing

The key & switch scanning and display timing diagram is given below. One cycle of key & switch scanning consists of 2 frames. The data of the 12 x 4 matrix is stored in the RAM.

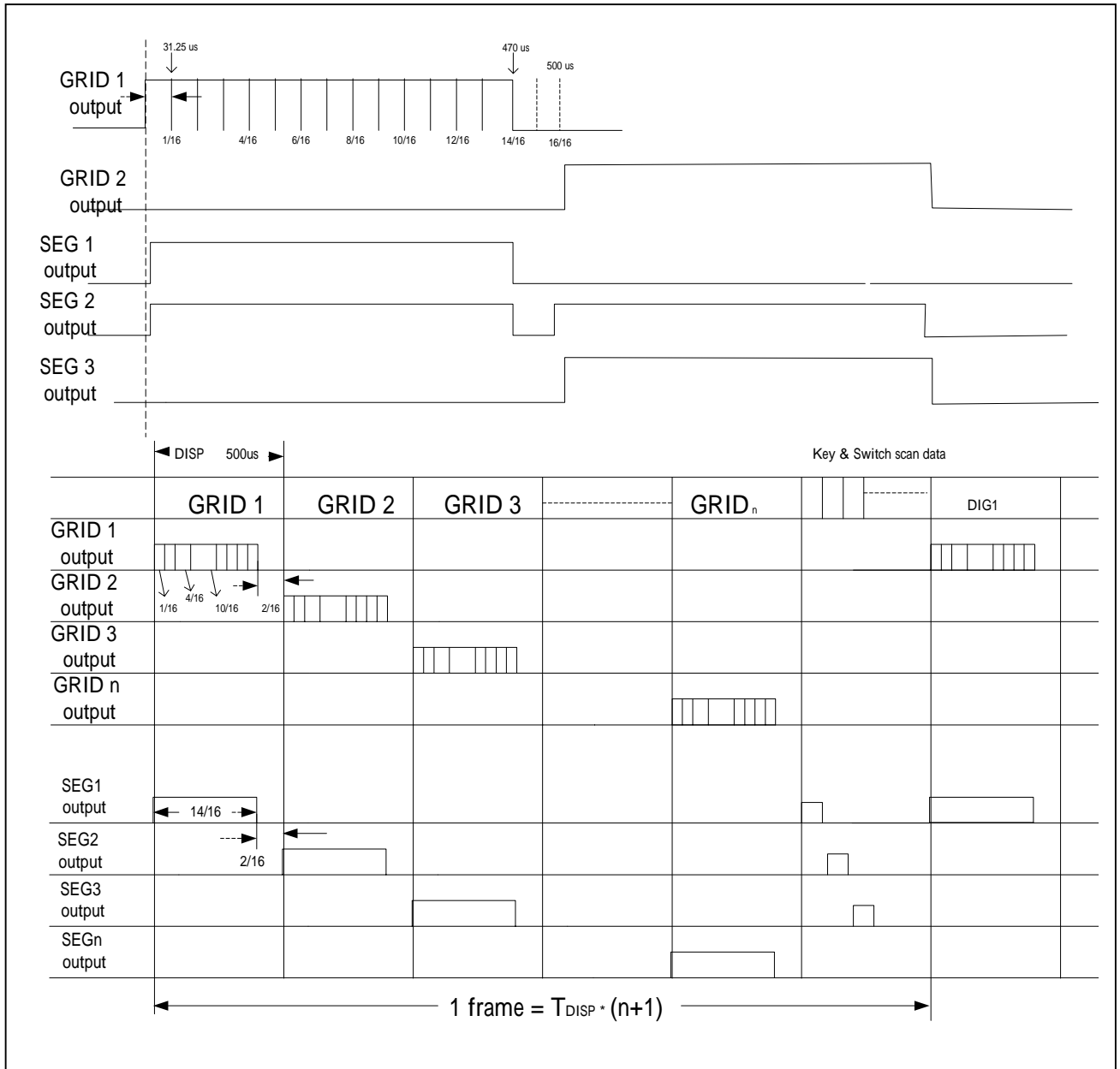

Fig. 18 Key & Switch Scanning and Display Timing Diagram

14 Serial/Parallel Communication Format

14.1 Reception (Command/Data Write)

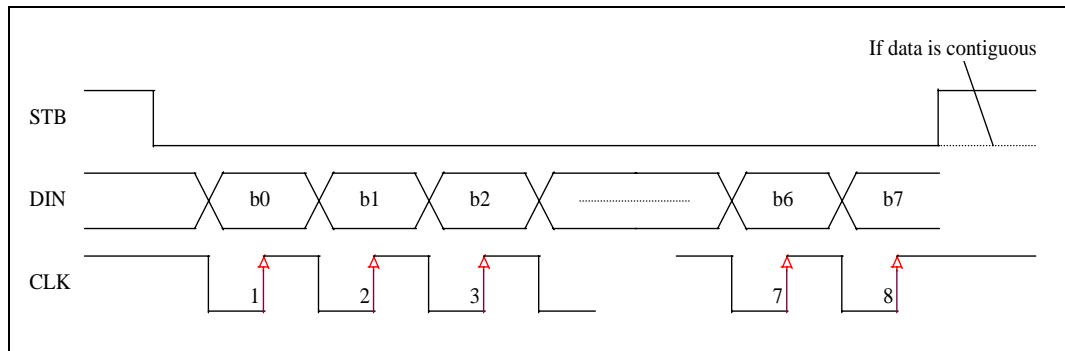

Fig. 19 Data Reception Timing Diagram

14.2 Transmission (Data Read)

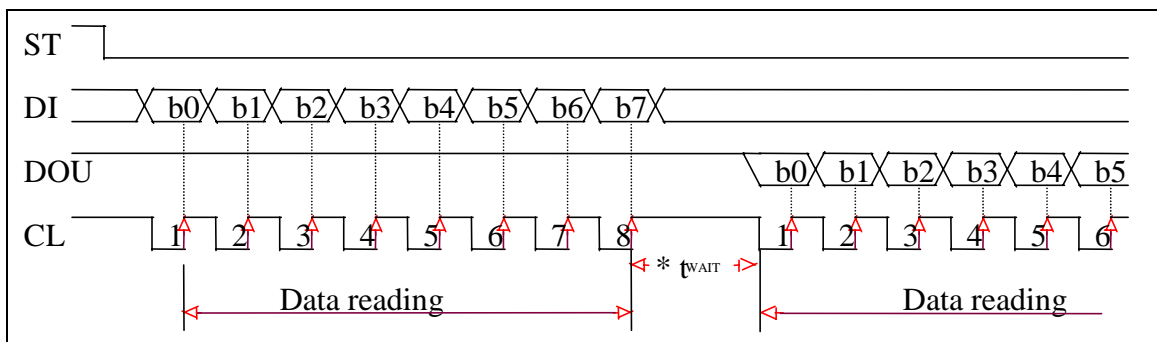

Fig. 20 Data Transmission Timing Diagram

When data is read, a wait time “t_{WAIT}” is necessary between the rising of the eighth clock that has set the command and the falling of the first clock that has read the data.

NOTE: The wait time is adjustable according to different applications.

15 Switching Characteristic Waveform

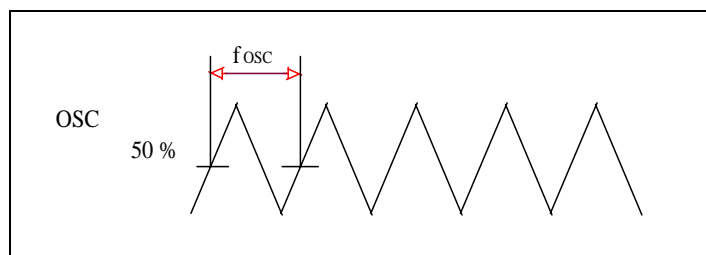

Fig. 21a Switching Characteristic Waveform

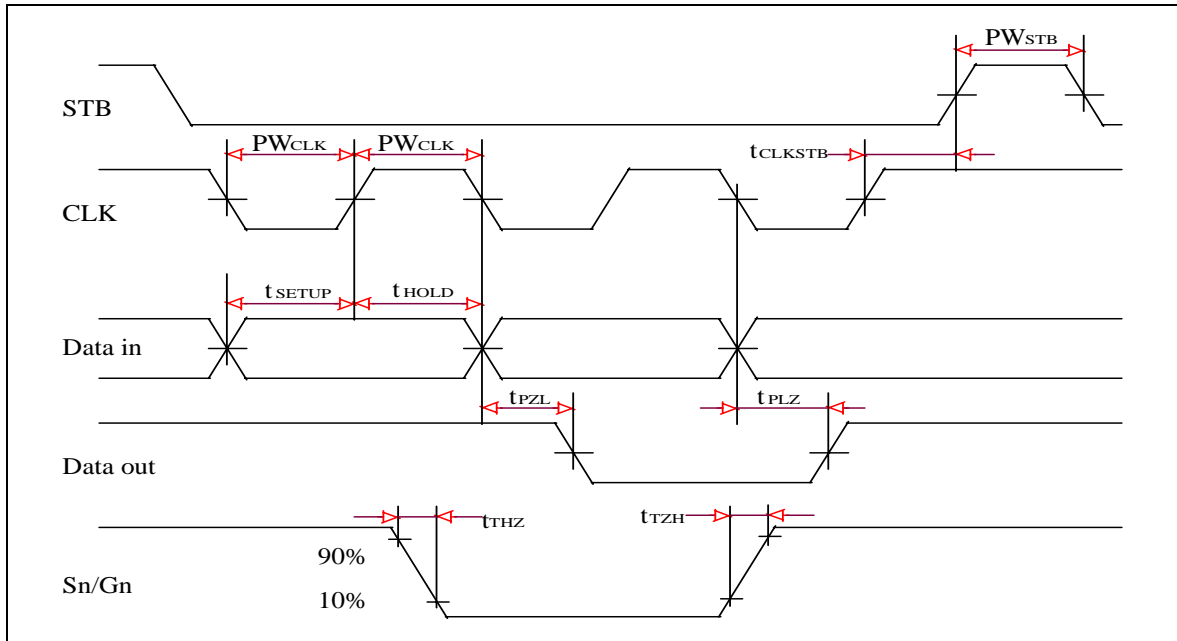

Fig. 21b Switching Characteristic Timing Diagram

15.1 Switching Characteristics (Ta = - 20 to + 70°C, VDD = 4.5 to 5.5V, VEE = VDD - 45V)

Parameter	Symbol	Min.	Typ.	Max.	Unit	Test Conditions
Oscillation frequency	tOSC	-	32.768	-	KHz	
Propagation delay time	tPLZ	-	-	300	ns	CLK→DOUT
	tPZL	-	-	100	ns	CL = 15pF, RL = 10KΩ
Rise time	tTZH1			2	us	CL = 100pF VEE=-25V SEG1/KS1 to SEG4/KS4, P24/SG5/KS5 to P20/SG9/KS9.
	tTZH2			0.5	μs	
Fall time	tTHZ	100	110	120	μs	CL = 100pF, VEE=-25V, SEGn, GRIDn
Data input clock freq.	fmax	-	1	1.25	MHz	Duty = 50 %, CLK
Input capacitance	CI			15	pF	
Clock pulse width	PWCLK	400	500	-	ns	
Strobe pulse width	PWSTB	0.8	1	-	μs	
Data setup time	tSETUP	100	-	-	ns	
Data hold time	tHOLD	100	-	-	ns	
Clock-Strobe time	tCLKSTB	0.8	1	-	μs	CLK↑→STB↑
Wait time	tWAIT	-	-	-	μs	CLK↑→CLK↑*

16 Serial I/F Sets Display Data Sequence

16.1 Updating Display Memory by Incrementing Address

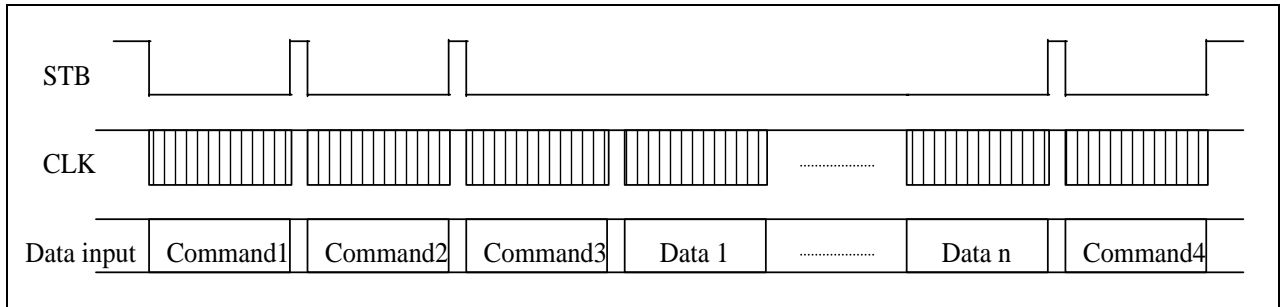

Fig. 22 incrementing Address Timing Diagram

Where:

- Command 1** : Display mode
- Command 2** : Sets data
- Command 3** : Sets address
- Data 1 to n** : Transfers display data (57 bytes max.)
- Command 4** : Controls display

16.2 Updating Specific Address

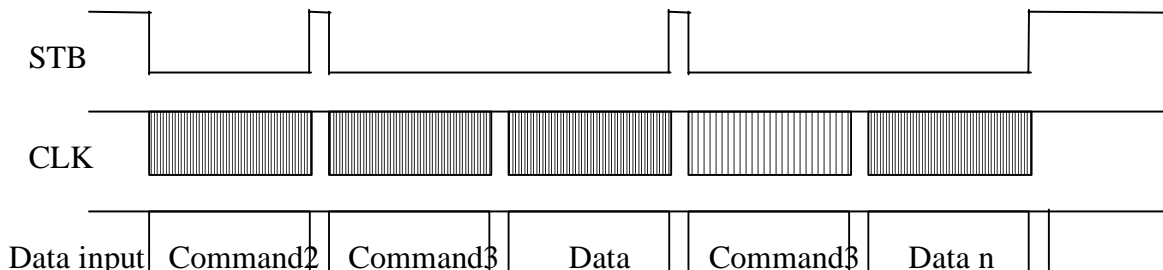

Fig. 23 Specific Address Timing Diagram

Where:

- Command 2** : Sets data
- Command 3** : Sets address
- Data** : Display data

17 Application

17.1 VFD Controller for DVD Player

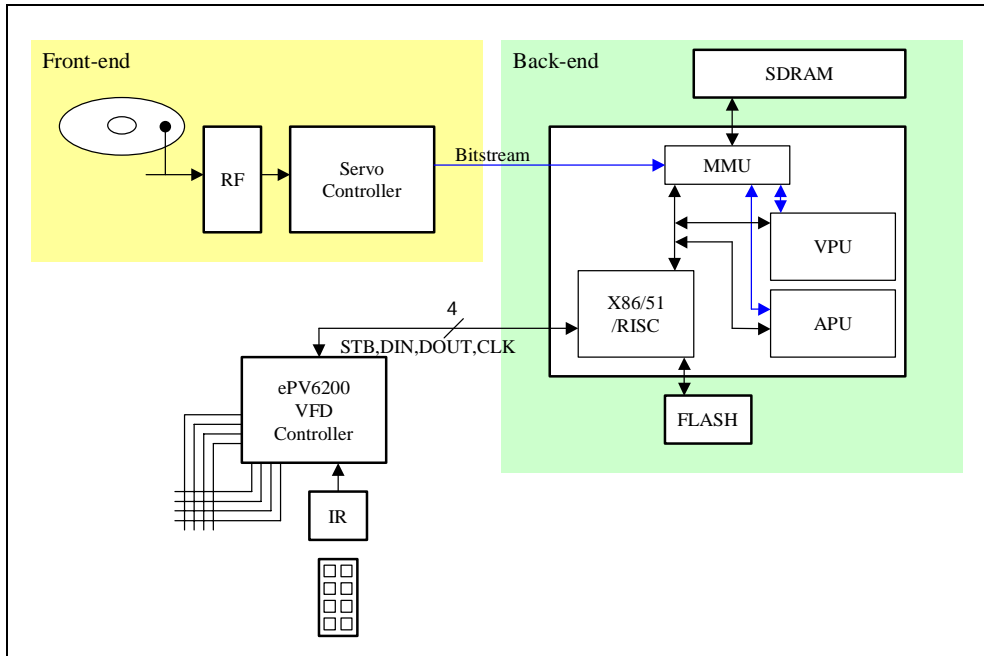

Fig. 24 Block Diagram for DVD Player Application

17.2 VFD Controller for Cascade Application

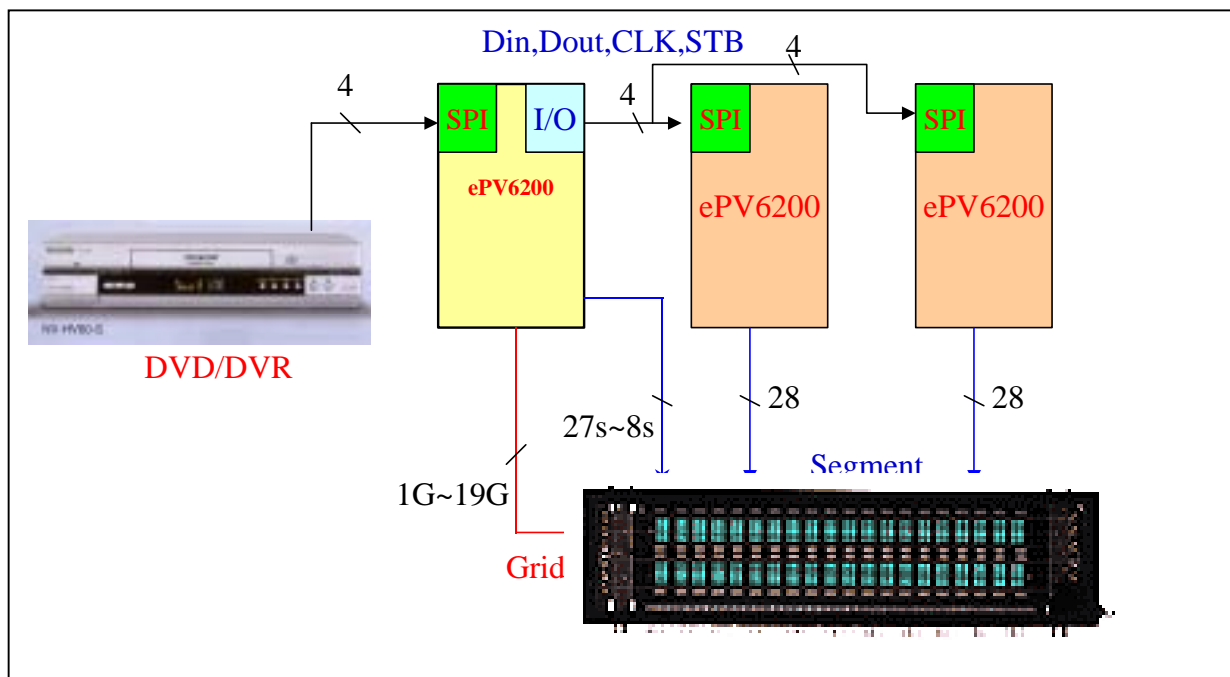
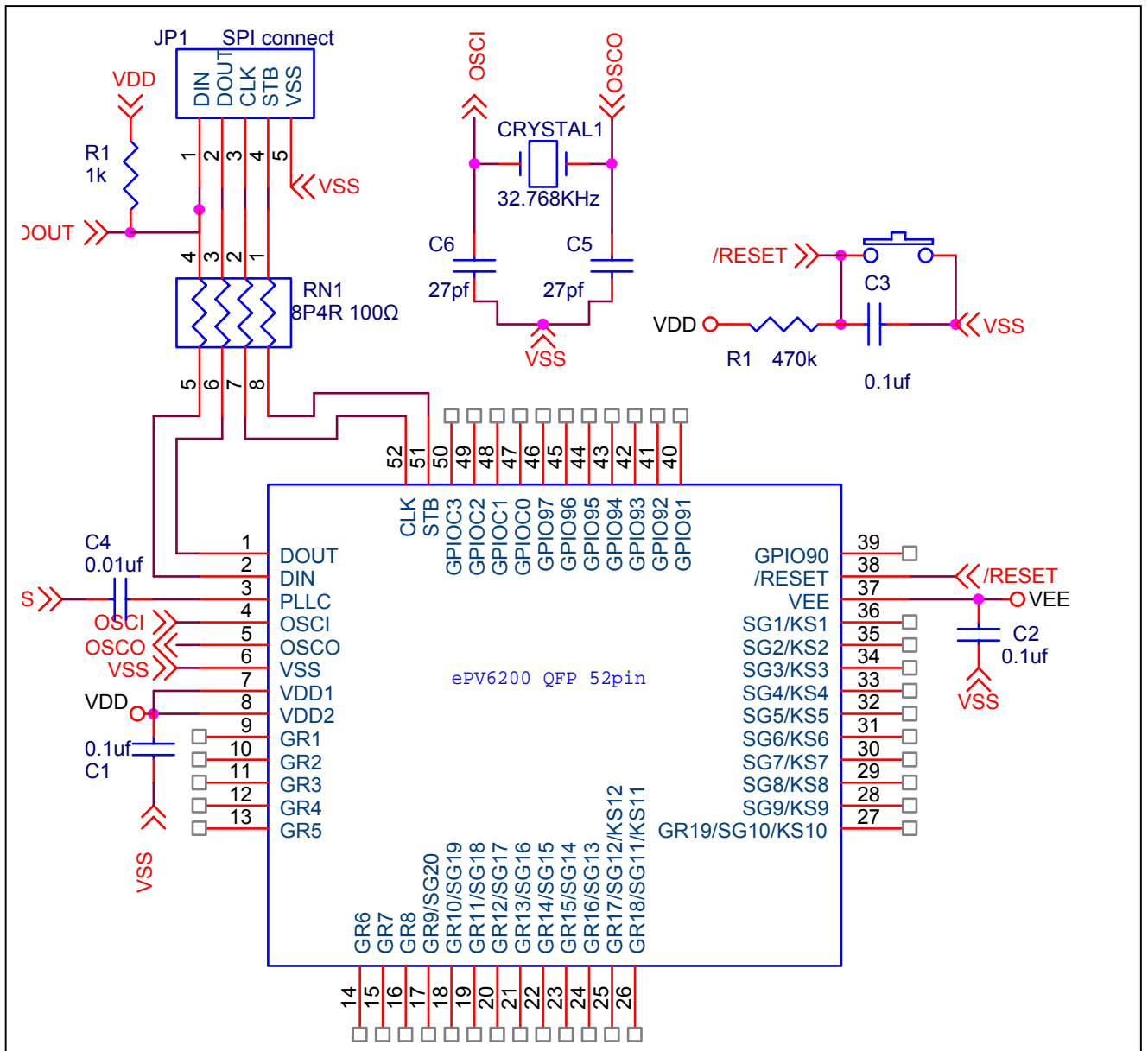

Fig. 25 Block Diagram for Cascade Application

17.3 application circuit



18 Package Information

(1) Package Type: Plastic QFP-52L

