

### Features

The serial configuration devices provide the following features:

- 1-, 4-, 16-, and 64-Mbit flash memory devices that serially configure Stratix® II FPGAs and the Cyclone™ series FPGAs using the active serial (AS) configuration scheme
- Easy-to-use four-pin interface
- Low cost, low pin count and non-volatile memory
- Low current during configuration and near-zero standby mode current
- 3.3-V operation
- Available in 8-pin and 16-pin small outline integrated circuit (SOIC) package
- Enables the Nios® processor to access unused flash memory through AS memory interface
- Re-programmable memory with more than 100,000 erase/program cycles
- Write protection support for memory sectors using status register bits
- In-system programming support with SRunner software driver
- Programming support with USB Blaster™ or ByteBlaster™ II download cables
- Additional programming support with the Altera® Programming Unit (APU) and programming hardware from BP Microsystems, System General, and other vendors
- Software design support with the Altera Quartus® II development system for Windows-based PCs as well as Sun SPARC station and HP 9000 Series 700/800
- Delivered with the memory array erased (all the bits set to 1)



Whenever the term “serial configuration device(s)” is used in this document, it refers to Altera EPCS1, EPCS4, EPCS16, and EPCS64 devices.

### Functional Description

With SRAM-based devices such as Stratix II FPGAs and the Cyclone series FPGAs, configuration data must be reloaded each time the device powers up, the system initializes, or when new configuration data is needed. Serial configuration devices are flash memory devices with a

serial interface that can store configuration data for a Stratix II FPGA or a Cyclone series device and reload the data to the device upon power-up or reconfiguration. Table 4-1 lists the serial configuration devices.

Device	Memory Size (Bits)
EPCS1	1,048,576
EPCS4	4,194,304
EPCS16	16,777,216 (1)
EPCS64	67,108,864 (1)

**Note to Table 4-1:**

(1) This information is preliminary.

You can vertically migrate from the EPCS1 to the EPCS4 device since they are offered in the same device package. Similarly, you can vertically migrate from the EPCS16 to the EPCS64 device.

Table 4-2 lists the serial configuration device used with each Stratix II FPGA and the configuration file size. Stratix II devices can only be used with EPCS16 or EPCS64 devices.

Stratix II Device	Raw Binary File Size (Bits) (1)	Serial Configuration Device	
		EPC16	EPCS64
EP2S15	5,000,000	✓	✓
EP2S30	10,100,000	✓	✓
EP2S60	17,100,000	✓ (2)	✓
EP2S90	27,500,000		✓
EP2S130	39,600,000		✓
EP2S180	52,400,000		✓

**Notes to Table 4-2:**

(1) These are preliminary, uncompressed file sizes.

(2) This is with the Stratix II compression feature enabled.

Table 4-3 lists the serial configuration device used with each Cyclone II FPGA and the configuration file size. Cyclone II devices can be used with all serial configuration devices.

Cyclone II Device	Raw Binary File Size (Bits) (1)	Serial Configuration Device			
		EPCS1	EPCS4	EPCS16	EPCS64
EP2C5	1,223,980	✓ (2)	✓	✓	✓
EP2C8	1,983,792		✓	✓	✓
EP2C20	3,930,986		✓	✓	✓
EP2C35	7,071,234			✓	✓
EP2C50	9,122,148			✓	✓
EP2C70	10,249,694			✓	✓

**Notes to Table 4-3:**

- (1) These are preliminary, uncompressed file sizes.
- (2) This is with the Cyclone II compression feature enabled.

Table 4-4 lists the serial configuration device used with each Cyclone FPGA and the configuration file size. Cyclone devices can only be used with EPCS1, EPCS4, or EPCS16 devices.

Cyclone Device	Raw Binary File Size (Bits) (1)	Serial Configuration Device		
		EPCS1	EPCS4	EPCS16
EP1C3	627,376	✓	✓	✓
EP1C4	925,000	✓	✓	✓
EP1C6	1,167,216	✓ (2)	✓	✓
EP1C12	2,326,528		✓	✓
EP1C20	3,559,608		✓	✓

**Notes to Table 4-4:**

- (1) These are preliminary, uncompressed file sizes.
- (2) This is with the Cyclone compression feature enabled.

With the new data-decompression feature in the Stratix II and Cyclone FPGA families, designers can use smaller serial configuration devices to configure larger FPGAs.

 Serial configuration devices cannot be cascaded.

 See *Configuring Stratix II Devices* in the Configuration Handbook for more information regarding the Stratix II FPGA decompression feature.

 See *Configuring Cyclone II Devices* in the Configuration Handbook for more information regarding the Cyclone II FPGA decompression feature.

 See *Configuring Cyclone FPGAs* in the Configuration Handbook for more information regarding the Cyclone FPGA decompression feature.

The serial configuration devices are designed to configure Stratix II FPGAs and the Cyclone series FPGAs and cannot configure other existing Altera device families.

Figure 4-1 shows the serial configuration device block diagram.

**Figure 4-1. Serial Configuration Device Block Diagram**

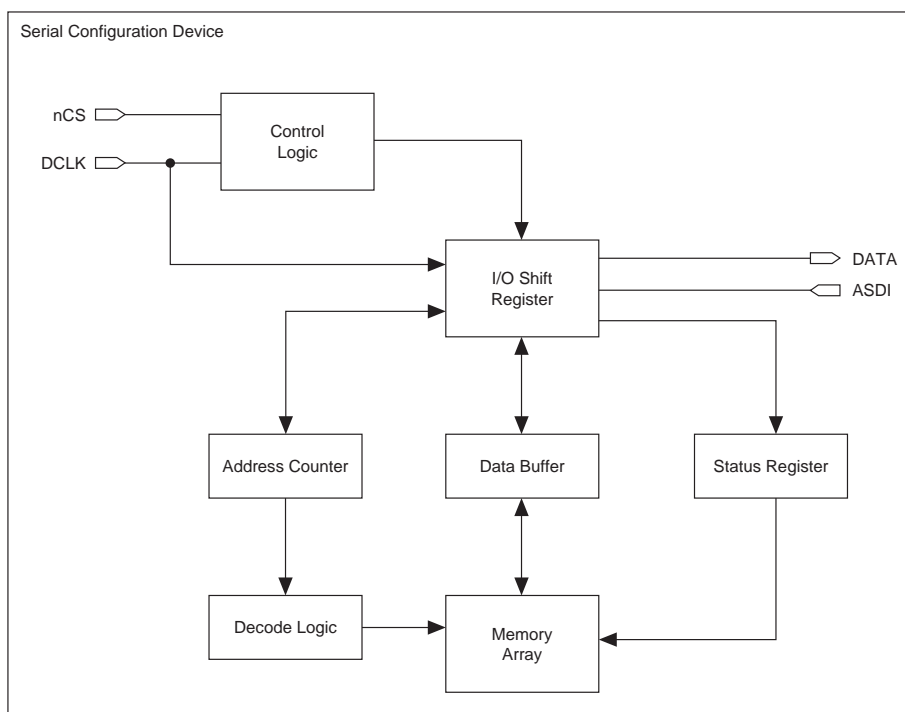

## Accessing Memory in Serial Configuration Devices

You can access the unused memory locations of the serial configuration device to store or retrieve data through the Nios processor and SOPC Builder. SOPC Builder is an Altera tool for creating bus-based (especially microprocessor-based) systems in Altera devices. SOPC Builder assembles library components like processors and memories into custom microprocessor systems.

SOPC Builder includes the active serial memory interface (ASMI) peripheral, an interface core specifically designed to work with the serial configuration device. Using this core, you can create a system with a Nios embedded processor that allows software access to any memory location within the serial configuration device.



For more information on accessing memory within the serial configuration device, see the *Active Serial Memory Interface Data Sheet*.

## Active Serial FPGA Configuration

Stratix II FPGAs and the Cyclone series FPGAs can be configured with a serial configuration device through the AS configuration mode.



This section is only relevant for FPGAs that support the Active Serial (AS) configuration scheme. Only Stratix II FPGAs and the Cyclone series FPGAs support the AS configuration scheme.

There are four signals on the serial configuration device that interface directly with the FPGA's control signals. The serial configuration device signals `DATA`, `DCLK`, `ASDI`, and `nCS` interface with `DATA0`, `DCLK`, `ASDO`, and `nCS0` control signals on the FPGA, respectively. [Figure 4-2](#) shows a serial configuration device programmed via a download cable which configures an FPGA in AS mode. [Figure 4-3](#) shows a serial configuration device programmed using the APU or a third-party programmer configuring an FPGA in AS configuration mode.

**Figure 4–2. FPGA Configuration in AS Mode (Serial Configuration Device Programmed Using Download Cable)**

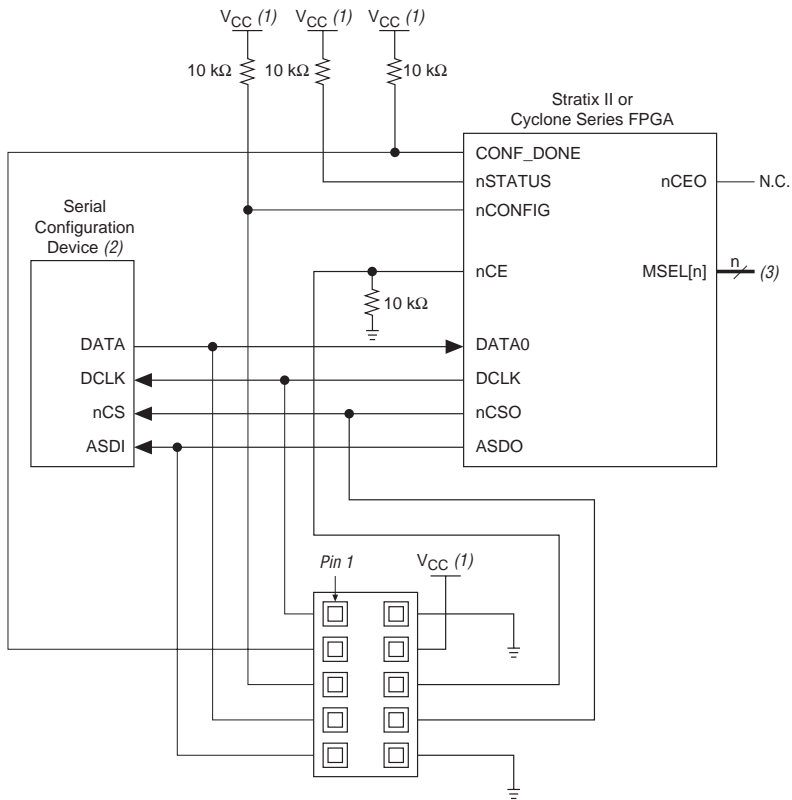

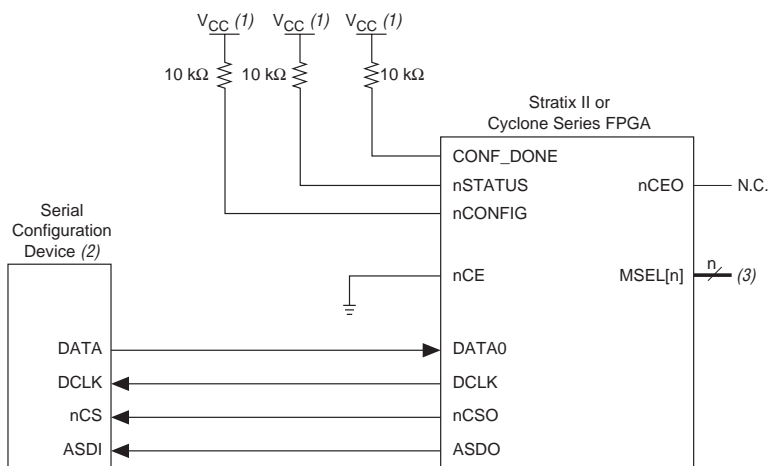
**Figure 4–3. FPGA Configuration in AS Mode (Serial Configuration Device Programmed by APU or Third-Party Programmer)****Notes to Figures 4–2 and 4–3:**



- (1)  $V_{CC} = 3.3\text{-V}$ .
- (2) Serial configuration devices cannot be cascaded.
- (3) Connect the FPGA  $MSEL[n]$  input pins to select the AS configuration mode. For details, refer to the appropriate FPGA family chapter in the Configuration Handbook.

The FPGA acts as the configuration master in the configuration flow and provides the clock to the serial configuration device. The FPGA enables the serial configuration device by pulling the  $nCS$  signal low via the  $nCSO$  signal (See Figures 4–2 and 4–3). Subsequently, the FPGA sends the instructions and addresses to the serial configuration device via the  $ASDO$  signal. The serial configuration device responds to the instructions by sending the configuration data to the FPGA's  $DATA0$  pin on the falling edge of  $DCLK$ . The data is latched into the FPGA on the  $DCLK$  signal's rising edge.

The FPGA controls the  $nSTATUS$  and  $CONF\_DONE$  pins during configuration in AS mode. If the  $CONF\_DONE$  signal does not go high at the end of configuration or if the signal goes high too early, the FPGA will pulse its  $nSTATUS$  pin low to start reconfiguration. Upon successful configuration, the FPGA releases the  $CONF\_DONE$  pin, allowing the external 10-k $\Omega$  resistor to pull this signal high. Initialization begins after the  $CONF\_DONE$  goes high. After initialization, the FPGA enters user mode.



For more information on configuring Stratix II FPGAs in AS mode or other configuration modes, see *Configuring Stratix II Devices* in the Configuration Handbook.

- 
 For more information on configuring Cyclone II FPGAs in AS mode or other configuration modes, see [Chapter 4, Configuring Cyclone II Devices](#) in the *Configuration Handbook, Volume 1*.
- 
 For more information on configuring Cyclone FPGAs in AS mode or other configuration modes, see [Chapter 5, Configuring Cyclone FPGAs](#) in the *Configuration Handbook, Volume 1*.

Multiple devices can be configured by a single EPCS device. However, serial configuration devices cannot be cascaded. Check [Table 4–1](#) to ensure the programming file size of the cascaded FPGAs does not exceed the capacity of a serial configuration device. [Figure 4–4](#) shows the AS configuration scheme with multiple FPGAs in the chain. The first Stratix II or Cyclone device is the configuration master and has its MSEL [ ] pins set to AS mode. The following FPGAs are configuration slave devices and have their MSEL [ ] pins set to PS mode.

**Figure 4–4. Multiple Devices in AS Mode**

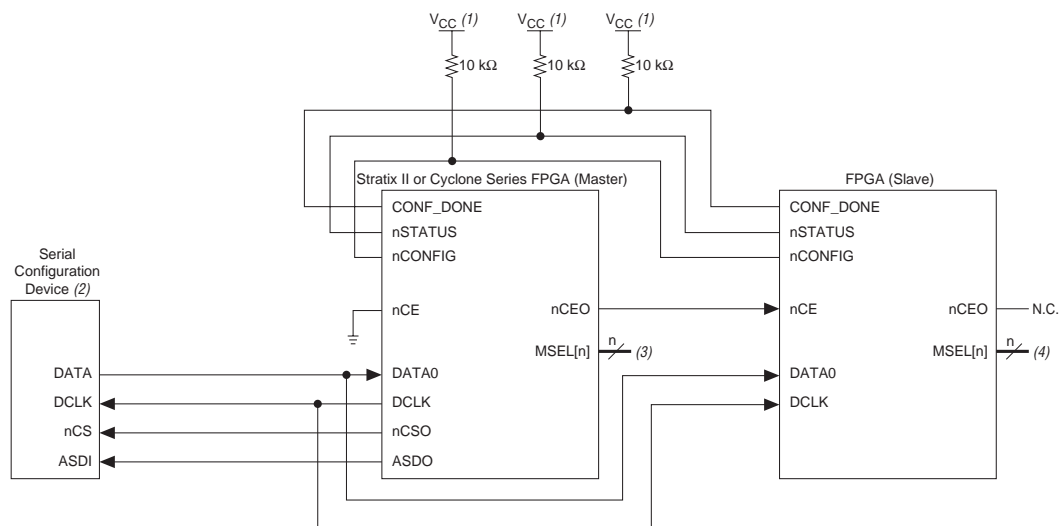

**Notes to [Figure 4–4](#):**

- (1)  $V_{CC} = 3.3\text{-V}$ .
- (2) Serial configuration devices cannot be cascaded.
- (3) Connect the FPGA MSEL [ ] input pins to select the AS configuration mode. For details, refer to the appropriate FPGA family chapter in the Configuration Handbook.
- (4) Connect the FPGA MSEL [ ] input pins to select the PS configuration mode. For details, refer to the appropriate FPGA family chapter in the Configuration Handbook.



## Serial Configuration Device Memory Access

This section describes the serial configuration device's memory array organization and operation codes. Timing specifications for the memory are provided in the ["Timing Information"](#) section.



Information on EPCS16 and EPCS64 devices will be available when devices are available.

### Memory Array Organization

[Table 4-5](#) provides details on the memory array organization in EPCS4 and EPCS1 devices.

Details	EPCS4	EPCS1
Bytes (bits)	524,888 bytes (4 Mbits)	131, 072 bytes (1 Mbit)
Number of sectors	8	4
Bytes (bits) per sector	65,536 bytes (512 Kbits)	32,768 bytes (256 Kbits)
Pages per sector	256	128
Total number of pages	2,048	512
Bytes per page	256 bytes	256 bytes

[Tables 4-6](#) and [4-7](#) show the address range for each sector in the EPCS4 and EPCS1 devices, respectively.

Sector	Address Range (Byte Addresses in HEX)	
	Start	End
7	H'70000	H'7FFFF
6	H'60000	H'6FFFF
5	H'50000	H'5FFFF
4	H'40000	H'4FFFF
3	H'30000	H'3FFFF
2	H'20000	H'2FFFF
1	H'10000	H'1FFFF
0	H'00000	H'0FFFF

**Table 4–7. Address Range for Sectors in EPCS1 Devices**

Sector	Address Range (Byte Addresses in HEX)	
	Start	End
3	H'18000	H'1FFFF
2	H'10000	H'17FFF
1	H'08000	H'0FFFF
0	H'00000	H'07FFF

## Operation Codes

This section describes the operations that can be used to access the memory in serial configuration devices. The `DATA`, `DCLK`, `ASDI`, and `nCS` signals access to the memory in serial configuration devices. All serial configuration device operation codes, addresses and data are shifted in and out of the device serially, with the most significant bit (MSB) first.

The device samples the active serial data input on the first rising edge of the `DCLK` after the active low chip select (`nCS`) input signal is driven low. Shift the operation code (MSB first) serially into the serial configuration device through the active serial data input pin. Each operation code bit is latched into the serial configuration device on the rising edge of the `DCLK`.

Different operations require a different sequence of inputs. While executing an operation, you must shift in the desired operation code, followed by the address bytes, data bytes, both, or neither. The device must drive `nCS` high after the last bit of the operation sequence is shifted in. [Table 4–8](#) shows the operation sequence for every operation supported by the serial configuration devices.

For the read byte, read status, and read silicon ID operations, the shifted-in operation sequence is followed by data shifted out on the `DATA` pin. You can drive the `nCS` pin high after any bit of the data-out sequence is shifted out.

For the write byte, erase bulk, erase sector, write enable, write disable, and write status operations, drive the `nCS` pin high exactly at a byte boundary (drive the `nCS` pin high a multiple of eight clock pulses after the `nCS` pin was driven low). Otherwise, the operation is rejected and will not be executed.

All attempts to access the memory contents while a write or erase cycle is in progress will not be granted, and the write or erase cycle will continue unaffected.

**Table 4–8. Operation Codes for Serial Configuration Devices**

Operation	Operation Code (1)	Address Bytes	Dummy Bytes	Data Bytes	DCLK $f_{MAX}$ (MHz)
Write enable	0000 0110	0	0	0	25
Write disable	0000 0100	0	0	0	25
Read status	0000 0101	0	0	1 to infinite (2)	25
Read bytes	0000 0011	3	0	1 to infinite (2)	20
Read silicon ID	1010 1011	0	3	1 to infinite (2)	25
Write status	0000 0001	0	0	1	25
Write bytes	0000 0010	3	0	1 to 256 (3)	25
Erase bulk	1100 0111	0	0	0	25
Erase sector	1101 1000	3	0	0	25

**Notes to Table 4–8:**

- (1) The MSB is listed first and the least significant bit (LSB) is listed last.
- (2) The status register, data or silicon ID are read out at least once on the DATA pin and will continuously be read out until nCS is driven high
- (3) Write bytes operation requires at least one data byte on the DATA pin. If more than 256 bytes are sent to the device, only the last 256 bytes are written to the memory.

### Write Enable Operation

The write enable operation code is b'0000 0110, and the most significant bit is listed first. The write enable operation sets the write enable latch bit, which is bit 1 in the status register. Always set the write enable latch bit before write bytes, write status, erase bulk, and erase sector operations. Figure 4–5 shows the timing diagram for the write enable operation. Figures 4–7 and 4–8 show the status register bit definitions.

**Figure 4–5. Write Enable Operation Timing Diagram**

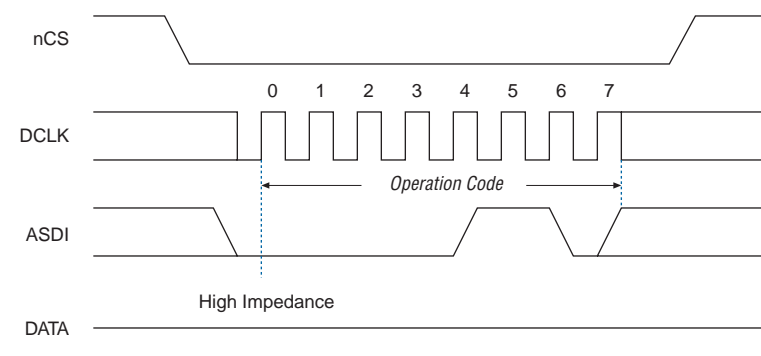

**Write Disable Operation**

The write disable operation code is  $b'0000\ 0100$ , with the MSB listed first. The write disable operation resets the write enable latch bit, which is bit 1 in the status register. To prevent the memory from being written unintentionally, the write enable latch bit is automatically reset when implementing the write disable operation as well as under the following conditions:

- Power up
- Write bytes operation completion
- Write status operation completion
- Erase bulk operation completion
- Erase sector operation completion

Figure 4–6 shows the timing diagram for the write disable operation.

**Figure 4–6. Write Disable Operation Timing Diagram**

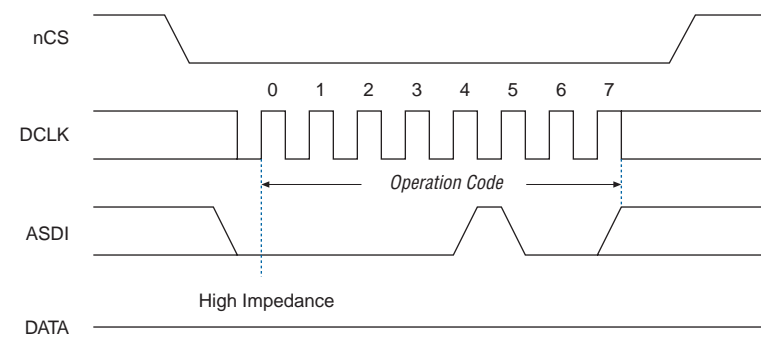

### Read Status Operation

The read status operation code is  $b'0000\ 0101$ , with the MSB listed first. You can use the read status operation to read the status register. Figures 4-7 and 4-8 show the status bits in the status register of both serial configuration devices.

**Figure 4-7. EPCS4 Status Register Status Bits**

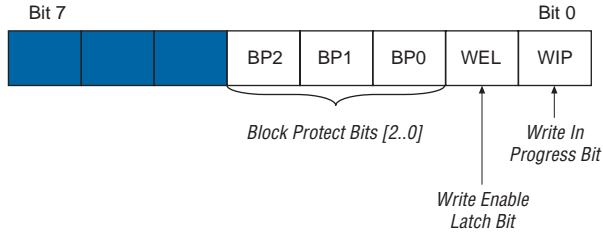

**Figure 4-8. EPCS1 Status Register Status Bits**

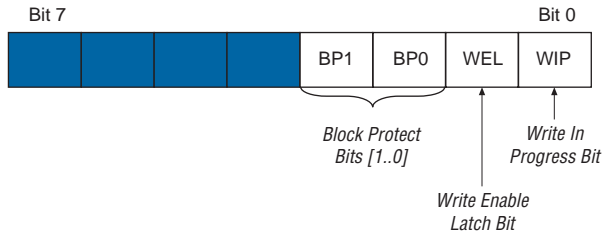

Setting the write in progress bit to 1 indicates that the serial configuration device is busy with a write or erase cycle. Resetting the write in progress bit to 0 means no write or erase cycle is in progress.

Resetting the write enable latch bit to 0 indicates that no write or erase cycle will be accepted. Set the write enable latch bit to 1 before every write bytes, write status, erase bulk, and erase sector operation.

The non-volatile block protect bits determine the area of the memory protected from being written or erased unintentionally. Tables 4-9 and 4-10 show the protected area in both serial configuration devices with reference to the block protect bits. The erase bulk operation is only

available when all the block protect bits are 0. When any of the block protect bits are set to one, the relevant area is protected from being written by write bytes operations or erased by erase sector operations.

**Table 4–9. Block Protection Bits in EPCS4 Devices**

Status Register Content			Memory Content	
BP2 Bit	BP1 Bit	BPO Bit	Protected Area	Unprotected Area
0	0	0	None	All eight sectors: 0 to 7
0	0	1	Sector 7	Seven sectors: 0 to 6
0	1	0	Sectors 6 and 7	Six sectors: 0 to 5
0	1	1	Four sectors: 4 to 7	Four sectors: 0 to 3
1	0	0	All sectors	None
1	0	1	All sectors	None
1	1	0	All sectors	None
1	1	1	All sectors	None

**Table 4–10. Block Protection Bits in EPCS1**

Status Register Content		Memory Content	
BP1 Bit	BPO Bit	Protected Area	Unprotected Area
0	0	None	All four sectors: 0 to 3
0	1	Sector 3	Three sectors: 0 to 2
1	0	Two sectors: 2 and 3	Two sectors: 0 and 1
1	1	All sectors	None

The status register can be read at any time, even while a write or erase cycle is in progress. When one of these cycles is in progress, you can check the write in progress bit (bit 0 of the status register) before sending a new operation to the device. The device can also read the status register continuously, as shown in [Figure 4–9](#).

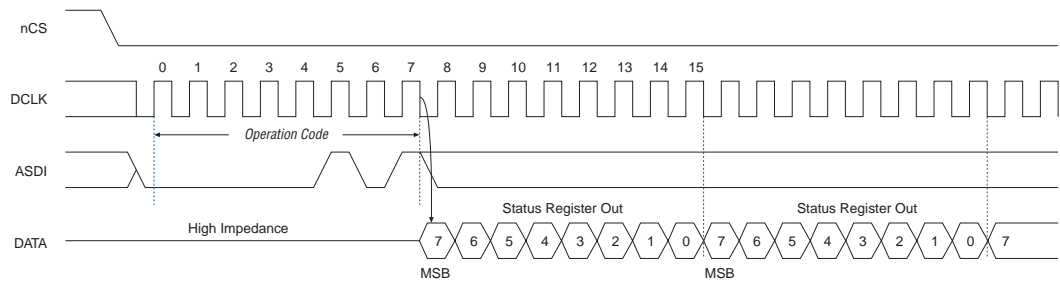
**Figure 4–9. Read Status Operation Timing Diagram**

### Write Status Operation

The write status operation code is  $b'0000\ 0001$ , with the MSB listed first. Use the write status operation to set the status register block protection bits. The write status operation has no effect on the other bits. Therefore, designers can implement this operation to protect certain memory sectors, as defined in [Tables 4–9](#) and [4–10](#). After setting the block protect bits, the protected memory sectors are treated as read-only memory. Designers must execute the write enable operation before the write status operation so the device sets the status register's write enable latch bit to 1.

The write status operation is implemented by driving **nCS** low, followed by shifting in the write status operation code and one data byte for the status register on the **ASDI** pin. [Figure 4–10](#) shows the timing diagram for the write status operation. **nCS** must be driven high after the eighth bit of the data byte has been latched in, otherwise, the write status operation is not executed.

Immediately after **nCS** is driven high, the device initiates the self-timed write status cycle. The self-timed write status cycle usually takes 5 ms for both serial configuration devices and is guaranteed to be less than 15 ms (see  $t_{WS}$  in [Table 4–12](#)). Designers must account for this delay to ensure that the status register is written with desired block protect bits. Alternatively, you can check the write in progress bit in the status register by executing the read status operation while the self-timed write status cycle is in progress. The write in progress bit is 1 during the self-timed write status cycle, and is 0 when it is complete.

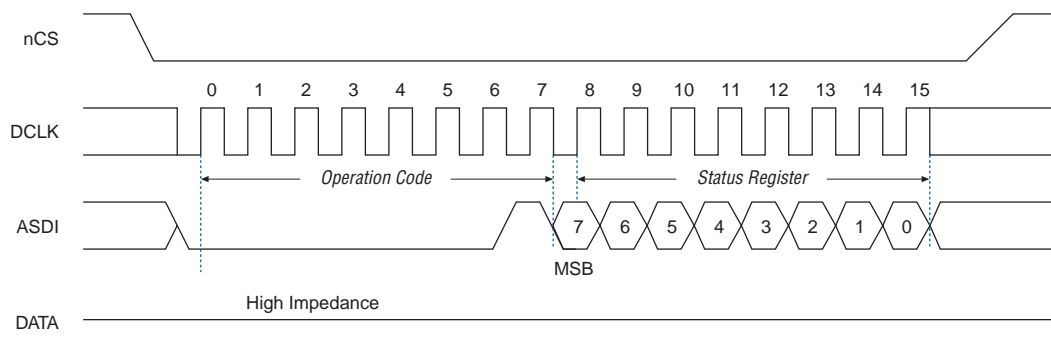
**Figure 4–10. Write Status Operation Timing Diagram**

### Read Bytes Operation

The read bytes operation code is  $b'0000\ 0011$ , with the MSB listed first. To read the memory contents of the serial configuration device, the device is first selected by driving  $nCS$  low. Then, the read bytes operation code is shifted-in followed by a 3-byte address ( $A[23..0]$ ). Each address bit must be latched-in on the rising edge of the DCLK. After the address is latched in, the memory contents of the specified address are shifted out serially on the DATA pin, beginning with the MSB. Each data bit is shifted out on the falling edge of DCLK. The maximum DCLK frequency during the read bytes operation is 20 MHz. Figure 4–11 shows the timing diagram for read bytes operation.

The first byte addressed can be at any location. The device automatically increments the address to the next higher address after shifting out each byte of data. Therefore, the device can read the whole memory with a single read bytes operation. When the device reaches the highest address, the address counter restarts at  $0 \times 000000$ , allowing the memory contents to be read out indefinitely until the read bytes operation is terminated by driving  $nCS$  high. The device can drive  $nCS$  high any time after data is shifted out. If the read bytes operation is shifted in while a write or erase cycle is in progress, the operation will not be executed. Additionally, it will not have any effect on the write or erase cycle in progress.



Figure 4–11. Read Bytes Operation Timing Diagram

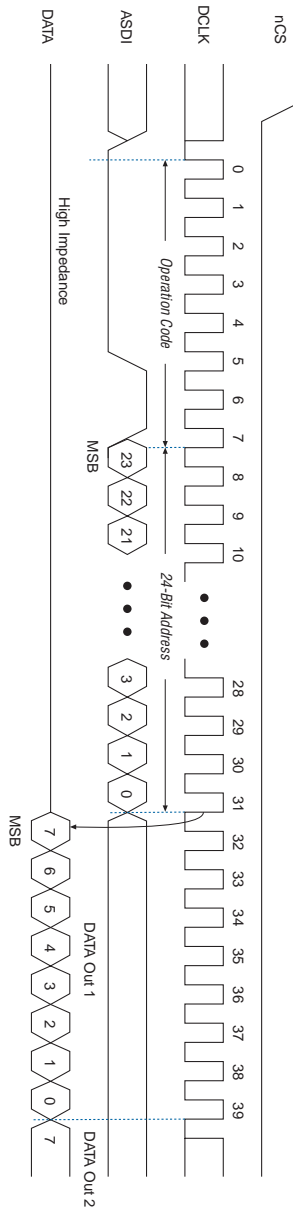

Note to Figure 4–11:

- (1) Address bits A[23..19] are don't care bits in the EPCS4 device. Address bits A[23..17] are don't care bits in the EPCS1 device.

### Read Silicon ID Operation

The read silicon ID operation code is  $b'1010\ 1011$ , with the MSB listed first. This operation reads the serial configuration device's 8-bit silicon ID from the `DATA` output pin. If this operation is shifted in during an erase or write cycle, it will be ignored and have no effect on the cycle that is in progress. [Table 4–11](#) shows the EPCS1 and EPCS4 device silicon IDs.

<b>Table 4–11. Serial Configuration Device Silicon ID</b>	
<b>Serial Configuration Device</b>	<b>Silicon ID (Binary Value)</b>
EPCS1	$b'0001\ 0000$
EPCS4	$b'0001\ 0010$

The device implements the read silicon ID operation by driving `nCS` low then shifting in the read silicon ID operation code followed by three dummy bytes on `ASDI`. The serial configuration device's 8-bit silicon ID is then shifted out on the `DATA` pin on the falling edge of `DCLK`, as shown in [Figure 4–12](#). The device can terminate the read silicon ID operation by driving `nCS` high after the silicon ID has been read at least once. Sending additional clock cycles on `DCLK` while `nCS` is driven low can cause the silicon ID to be shifted out repeatedly.

Figure 4–12. Read Silicon ID Operation Timing Diagram

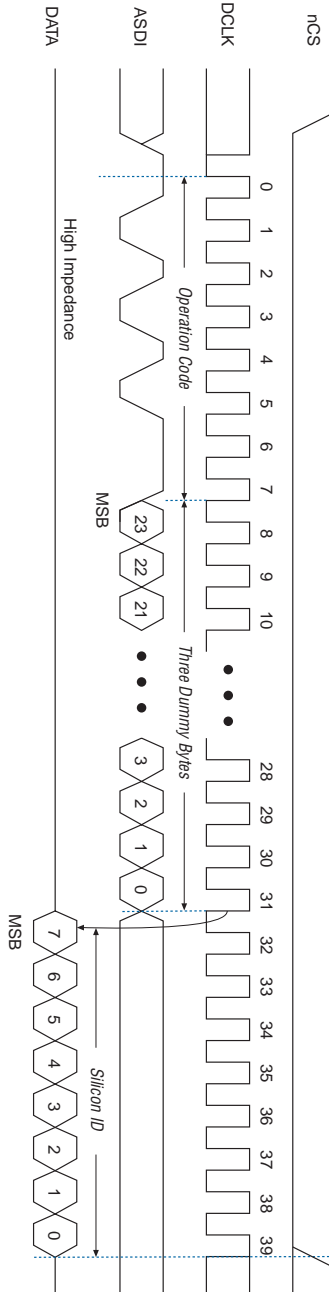

### *Write Bytes Operation*

The write bytes operation code is `b'0000 0010`, with the MSB listed first. The write bytes operation allows bytes to be written to the memory. The write enable operation must be executed prior to the write bytes operation to set the write enable latch bit in the status register to 1.

The write bytes operation is implemented by driving `nCS` low, followed by the write bytes operation code, three address bytes and a minimum one data byte on `ASDI`. If the eight least significant address bits (`A[7..0]`) are not all 0, all sent data that goes beyond the end of the current page is not written into the next page. Instead, this data is written at the start address of the same page (from the address whose eight LSBs are all 0). Drive `nCS` low during the entire write bytes operation sequence as shown in [Figure 4–13](#).

If more than 256 data bytes are shifted into the serial configuration device with a write bytes operation, the previously latched data is discarded and the last 256 bytes are written to the page. However, if less than 256 data bytes are shifted into the serial configuration device, they are guaranteed to be written at the specified addresses and the other bytes of the same page are unaffected.

If the design must write more than 256 data bytes to the memory, it needs more than one page of memory. Send the write enable and write bytes operation codes followed by three new targeted address bytes and 256 data bytes before a new page is written.

`nCS` must be driven high after the eighth bit of the last data byte has been latched in. Otherwise, the device will not execute the write bytes operation. The write enable latch bit in the status register is reset to 0 before the completion of each write bytes operation. Therefore, the write enable operation must be carried out before the next write bytes operation.

The device initiates the self-timed write cycle immediately after `nCS` is driven high. The self-timed write cycle usually takes 1.5 ms for EPCS4 devices and 2 ms for EPCS1 devices and is guaranteed to be less than 5 ms (see  $t_{WB}$  in [Table 4–12](#)). Therefore, the designer must account for this amount of delay before another page of memory is written. Alternatively, the designer can check the status register's write in progress bit by executing the read status operation while the self-timed write cycle is in progress. The write in progress bit is set to 1 during the self-timed write cycle, and is 0 when it is complete.

Figure 4–13. Write Bytes Operation Timing Diagram

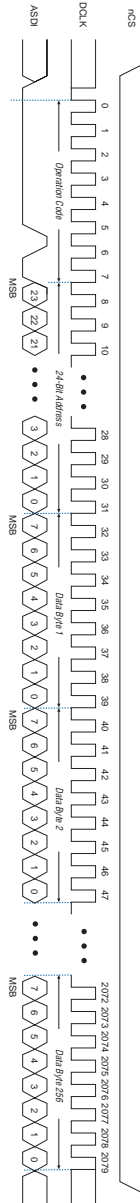

Note to Figure 4–13:

- (1) Address bits A[23 . . 19] are don't care bits in the PCS4 device. Address bits A[23 . . 17] are the don't care bits in the EPCS1 device.

### Erase Bulk Operation

The erase bulk operation code is  $b'1100\ 0111$ , with the MSB listed first. The erase bulk operation sets all memory bits to 1 or  $0xFF$ . Similar to the write bytes operation, the write enable operation must be executed prior to the erase bulk operation so that the write enable latch bit in the status register is set to 1.

Designers implement the erase bulk operation by driving  $nCS$  low and then shifting in the erase bulk operation code on the  $ASDI$  pin.  $nCS$  must be driven high after the eighth bit of the erase bulk operation code has been latched in. Figure 4–14 shows the timing diagram.

The device initiates the self-timed erase bulk cycle immediately after  $nCS$  is driven high. The self-timed erase bulk cycle usually takes 5 s for EPCS4 devices (guaranteed to be less than 10 s) or 3 s for EPCS1 devices (guaranteed to be less than 6 s). See  $t_{EB}$  in Table 4–12. Designers must account for this delay before accessing the memory contents. Alternatively, designers can check the write in progress bit in the status register by executing the read status operation while the self-timed erase cycle is in progress. The write in progress bit is 1 during the self-timed erase cycle and is 0 when it is complete. The write enable latch bit in the status register is reset to 0 before the erase cycle is complete.

**Figure 4–14. Erase Bulk Operation Timing Diagram**

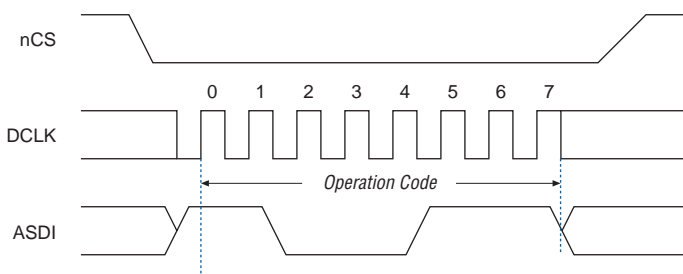

### Erase Sector Operation

The erase sector operation code is  $b'1101\ 1000$ , with the MSB listed first. The erase sector operation allows the user to erase a certain sector in the serial configuration device by setting all bits inside the sector to 1 or  $0xFF$ . This operation is useful for users who access the unused sectors as general purpose memory in their applications.

The write enable operation must be executed prior to the erase sector operation so that the write enable latch bit in the status register is set to 1.

The erase sector operation is implemented by first driving  $nCS$  low, then shifting in the erase sector operation code and the three address bytes of the chosen sector on the  $ASDI$  pin. The three address bytes for the erase sector operation can be any address inside the specified sector. (See Tables 4–6 and 4–7 for sector address range information.) Drive  $nCS$  high after the eighth bit of the erase sector operation code has been latched in. Figure 4–15 shows the timing diagram.

Immediately after the device drives  $nCS$  high, the self-timed erase sector cycle is initiated. The self-timed erase sector cycle usually takes 2 s for EPCS1 and EPCS4 devices and is guaranteed to be less than 3 s for both serial configuration devices. You must account for this amount of delay before the memory contents can be accessed. Alternatively, you can check the write in progress bit in the status register by executing the read status operation while the erase cycle is in progress. The write in progress bit is 1 during the self-timed erase cycle and is 0 when it is complete. The write enable latch bit in the status register is reset to 0 before the erase cycle is complete.

**Figure 4–15. Erase Sector Operation Timing Diagram**

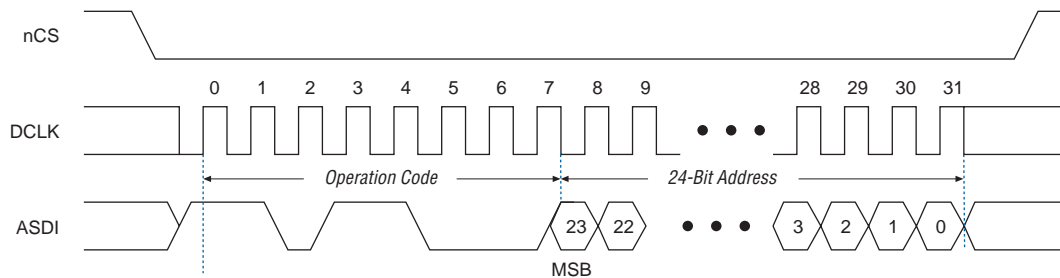

## Power & Operation

This section describes the power modes, power-on reset (POR) delay, error detection, and initial programming state of serial configuration devices.

### Power Mode

Serial configuration devices support active power and standby power modes. When  $nCS$  is low, the device is enabled and is in active power mode. The FPGA is configured while in active power mode. When  $nCS$  is high, the device is disabled but could remain in active power mode until all internal cycles have completed (such as write or erase operations). The serial configuration device then goes into stand-by power mode. The  $I_{CC1}$

parameter specifies the  $V_{CC}$  supply current when the device is in active power mode and the  $I_{CC0}$  parameter specifies the current when the device is in stand-by power mode (see [Table 4-18](#)).

### Power-On Reset

During initial power-up, a POR delay occurs to ensure the system voltage levels have stabilized. During AS configuration, the FPGA controls the configuration and has a longer POR delay than the serial configuration device. Therefore, the POR delay is governed by the Stratix II FPGA (typically 12 ms or 100 ms) or Cyclone series FPGA (typically 100 ms).

### Error Detection

During AS configuration with the serial configuration device, the FPGA monitors the configuration status through the `nSTATUS` and `CONF_DONE` pins. If an error condition occurs (`nSTATUS` drives low) or if the `CONF_DONE` pin does not go high, the FPGA will initiate reconfiguration by pulsing the `nSTATUS` and `nCSO` signals, which controls the chip select pin on the serial configuration device (`nCS`).

After an error, configuration automatically restarts if the *Auto-Restart Upon Frame Error* option is turned on in the Quartus II software. If the option is turned off, the system must monitor the `nSTATUS` signal for errors and then pulse the `nCONFIG` signal low to restart configuration.

## Timing Information

[Figure 4-16](#) shows the timing waveform for write operation to the serial configuration device.

**Figure 4-16. Write Operation Timing**

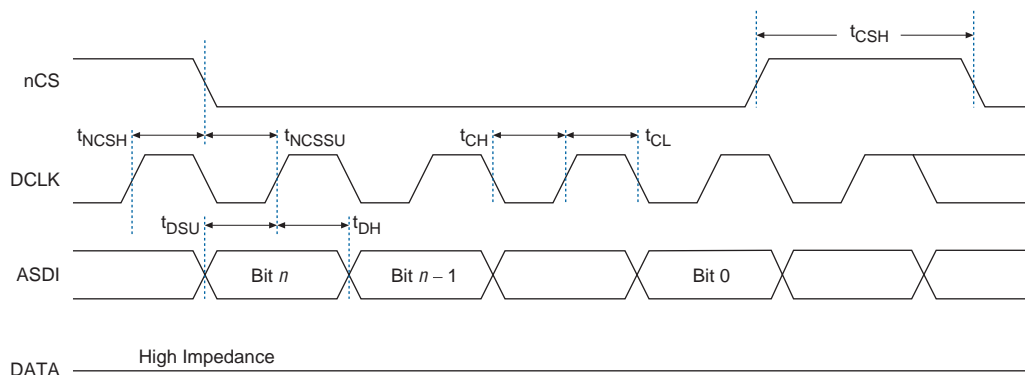



Table 4–12 defines the serial configuration device timing parameters for write operation.

Symbol	Parameter	Min	Max	Unit
$f_{WCLK}$	Write clock frequency (from FPGA, download cable, or embedded processor) for write enable, write disable, read status, read silicon ID, write bytes, erase bulk, and erase sector operations		25	MHz
$t_{CH}$	DCLK high time	20		ns
$t_{CL}$	DCLK low time	20		ns
$t_{NCSSU}$	Chip select ( $nCS$ ) setup time	10		ns
$t_{NCSH}$	Chip select ( $nCS$ ) hold time	10		ns
$t_{DSU}$	Data (ASDI) in setup time before rising edge on DCLK	5		ns
$t_{DH}$	Data (ASDI) hold time after rising edge on DCLK	5		ns
$t_{CSH}$	Chip select high time	100		ns
$t_{WB\_EPCS1}$ (1)	Write bytes cycle time for EPCS1 devices	2	5	ms
$t_{WB\_EPCS4}$ (1)	Write bytes cycle time for EPCS4 devices	1.5	5	ms
$t_{WS}$ (1)	Write status cycle time	5	15	ms
$t_{EB\_EPCS1}$ (1)	Erase bulk cycle time for EPCS1 devices	3	6	s
$t_{EB\_EPCS4}$ (1)	Erase bulk cycle time for EPCS4 devices	5	10	s
$t_{ES}$ (1)	Erase sector cycle time	2	3	s

**Note to Table 4–12:**

(1) These parameters are not shown in Figure 4–16.

Figure 4–17 shows the timing waveform for the serial configuration device's read operation.

**Figure 4–17. Read Operation Timing**

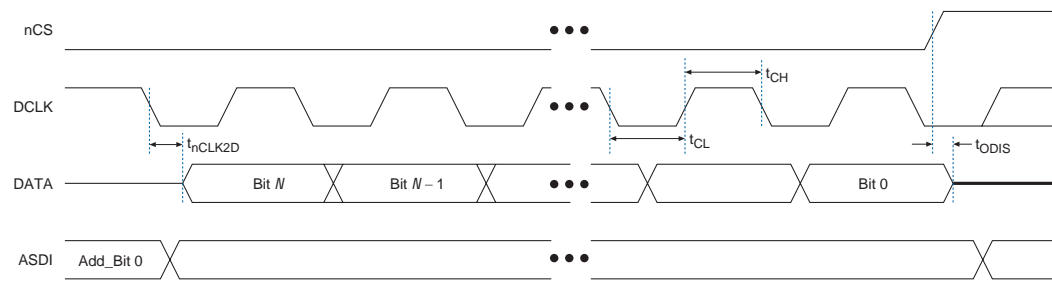

Table 4–13 defines the serial configuration device timing parameters for read operation.

Symbol	Parameter	Min	Max	Unit
$f_{RCLK}$	Read clock frequency (from FPGA or embedded processor) for read bytes operation		20	MHz
$t_{CH}$	DCLK high time	25		ns
$t_{CL}$	DCLK low time	25		ns
$t_{ODIS}$	Output disable time after read		15	ns
$t_{nCLK2D}$	Clock falling edge to data		15	ns

Figure 4–18 shows the timing waveform for FPGA AS configuration scheme using a serial configuration device.

**Figure 4–18. AS Configuration Timing**

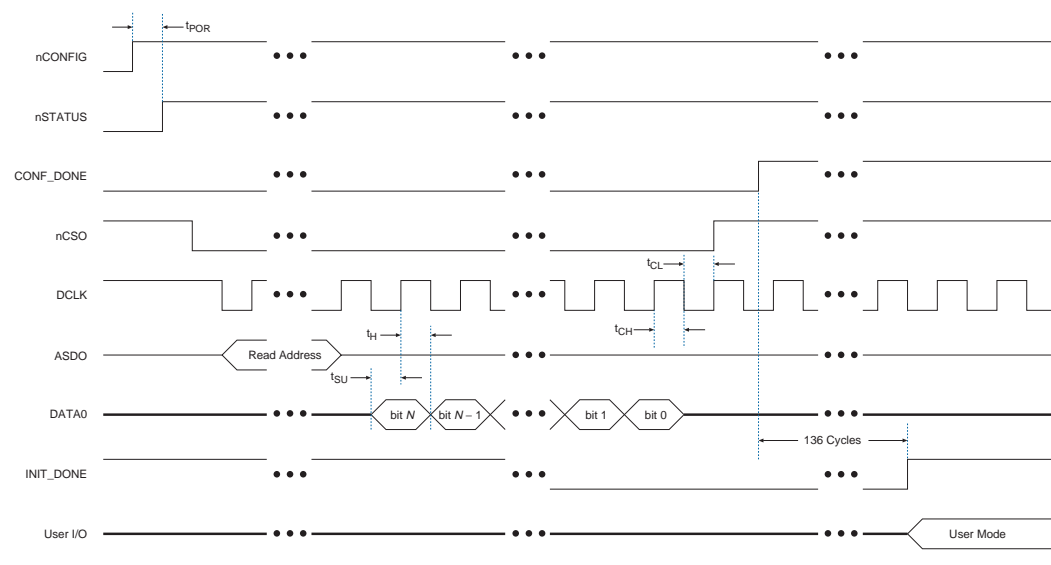

Table 4–14 shows the timing parameters for AS configuration mode.

Symbol	Parameter	Min	Typ	Max	Unit
$f_{CLK}$	DCLK frequency from Cyclone FPGA	14	17	20	MHz
$f_{CLK}$	DCLK frequency from Stratix II or Cyclone II FPGA (1)	20 (2)	26 (2)	40 (2)	MHz
		10	13	20	MHz
$t_{CH}$	DCLK high time	25			ns
$t_{CL}$	DCLK low time	25			ns
$t_H$	Data hold time after rising edge on DCLK	0			ns
$t_{SU}$	Data set up time before rising edge on DCLK	5			ns
$t_{POR}$	POR delay			100	ms

**Notes to Table 4–14:**

- (1) These values are preliminary
- (2) Only the EPCS16 and EPCS64 devices support a DCLK frequency up to 40 MHz.

## Programming & Configuration File Support

The Quartus II design software provides programming support for serial configuration devices. After selecting the serial configuration device, the Quartus II software automatically generates the Programmer Object File (.pof) to program the device. The software allows users to select the appropriate serial configuration device density that most efficiently stores the configuration data for a selected FPGA.

The serial configuration device can be programmed in-system by an external microprocessor using SRRunner. SRRunner is a software driver developed for embedded serial configuration device programming that designers can customize to fit in different embedded systems. The SRRunner can read a Raw Programming Data file (.rpd) and write to the serial configuration devices. The programming time is comparable to the Quartus II software programming time.



For more information about SRRunner, see the *SRRunner: An Embedded Solution for Serial Configuration Device Programming White Paper* and the source code on the Altera web site ([www.altera.com](http://www.altera.com)).

Serial configuration devices can be programmed using the APU with the appropriate programming adapter (PLMSEPC-8 or PLMSEPC-16) via the Quartus II software, USB Blaster, or the ByteBlaster II download cable via the Quartus II software. In addition, many third-party programmers, such as BP Microsystems and System General, offer programming hardware that supports serial configuration devices.

During in-system programming of a serial configuration device via the USB Blaster or ByteBlaster II download cable, the cable pulls `nCONFIG` low to reset the FPGA and overrides the 10-k $\Omega$  pull-down resistor on the FPGA's `nCE` pin (see [Figure 4-2](#)). The download cable then uses the four interface pins (`DATA`, `nCS`, `ASDI`, and `DCLK`) to program the serial configuration device. Once the programming is complete, the download cable releases the serial configuration device's four interface pins and the FPGA's `nCE` pin, and pulses `nCONFIG` to start configuration.



For more information on programming and configuration support, see the following documents:

- *Altera Programming Hardware Data Sheet*
- *Programming Hardware Manufacturers*
- *USB Blaster USB Port Download Cable Development Tools Data Sheet*
- *ByteBlaster II Parallel Port Download Cable Data Sheet*

## Operating Conditions

Tables 4–15 through 4–19 provide information on absolute maximum ratings, recommended operating conditions, DC operating conditions, and capacitance for serial configuration devices.

**Table 4–15. Absolute Maximum Ratings** *Note (1)*

Symbol	Parameter	Condition	Min	Max	Unit
$V_{CC}$	Supply voltage	With respect to ground	-0.6	4.0	V
$V_I$	DC input voltage	With respect to ground	-0.6	4.0	V
$I_{MAX}$	DC $V_{CC}$ or GND current			15	mA
$I_{OUT}$	DC output current per pin		-25	25	mA
$P_D$	Power dissipation			54	mW
$T_{STG}$	Storage temperature	No bias	-65	150	°C
$T_{AMB}$	Ambient temperature	Under bias	-65	135	°C
$T_J$	Junction temperature	Under bias		135	°C

**Table 4–16. Recommended Operating Conditions**

Symbol	Parameter	Conditions	Min	Max	Unit
$V_{CC}$	Supply voltage	(2)	3.0	3.6	V
$V_I$	Input voltage	Respect to GND	-0.3	$0.3 + V_{CC}$	V
$V_O$	Output voltage		0	$V_{CC}$	V
$T_A$	Operating temperature	For commercial use	0	70	°C
		For industrial use	-40	85	°C
$t_R$	Input rise time			5	ns
$t_F$	Input fall time			5	ns

**Table 4–17. DC Operating Conditions**

Symbol	Parameter	Conditions	Min	Max	Unit
$V_{IH}$	High-level input voltage		$0.7 \times V_{CC}$	$V_{CC} + 0.4$	V
$V_{IL}$	Low-level input voltage		-0.5	$0.3 \times V_{CC}$	V
$V_{OH}$	High-level output voltage	$I_{OH} = -100 \mu A$ (3)	$V_{CC} - 0.2$		V
$V_{OL}$	Low-level output voltage	$I_{OL} = 1.6 \text{ mA}$ (3)		0.4	V
$I_I$	Input leakage current	$V_I = V_{CC}$ or GND	-10	10	$\mu A$
$I_{OZ}$	Tri-state output off-state current	$V_O = V_{CC}$ or GND	-10	10	$\mu A$

**Table 4–18.  $I_{CC}$  Supply Current**

Symbol	Parameter	Conditions	Min	Max	Unit
$I_{CC0}$	$V_{CC}$ supply current (standby)			50	$\mu\text{A}$
$I_{CC1}$	$V_{CC}$ supply current (during active power mode)		5	14	mA

**Table 4–19. Capacitance** *Note (4)*

Symbol	Parameter	Conditions	Min	Max	Unit
$C_{IN}$	Input pin capacitance	$V_{IN} = 0\text{ V}$		6	pF
$C_{OUT}$	Output pin capacitance	$V_{OUT} = 0\text{ V}$		8	pF

**Notes to Table 4–15 through 4–19:**

- (1) See the *Operating Requirements for Altera Devices Data Sheet*.
- (2) Maximum  $V_{CC}$  rise time is 100 ms.
- (3) The  $I_{OH}$  parameter refers to high-level TTL or CMOS output current; the  $I_{OL}$  parameter refers to low-level TTL or CMOS output current.
- (4) Capacitance is sample-tested only at  $T_A = 25^\circ\text{C}$  and at a 20-MHz frequency.

## Pin Information

As shown in [Figure 4–19](#), the serial configuration device is an 8-pin or 16-pin device. The control pins on the serial configuration device are: serial data output (DATA), active serial data input (ASDI), serial clock (DCLK), and chip select (nCS). [Table 4–20](#) shows the serial configuration device's pin descriptions.

[Figure 4–19](#) shows the Altera serial configuration device 8-pin SOIC package and its pin-out diagram.

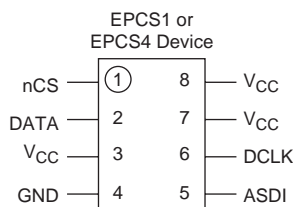
**Figure 4–19. Altera Serial Configuration Device 8-Pin SOIC Package Pin-Out Diagram**

[Figure 4–20](#) shows the Altera serial configuration device 16-pin SOIC package and its pin-out diagram.

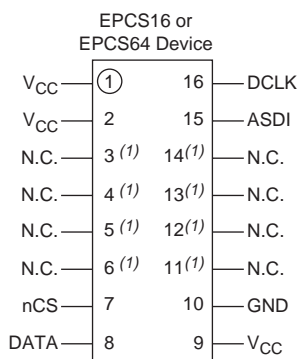
**Figure 4–20. Altera Serial Configuration Device 16-Pin SOIC Package Pin-Out Diagram****Note to Figure 4–20:**

- (1) These pins can be left floating or connected to V<sub>cc</sub> or GND, whichever is more convenient on the board.

**Table 4–20. Serial Configuration Device Pin Description**

Pin Name	Pin Number	Pin Type	Description
DATA	2	Output	The DATA output signal transfers data serially out of the serial configuration device to the FPGA during read/configuration operation. During a read/configuration operations, the serial configuration device is enabled by pulling nCS low. The DATA signal transitions on the falling edge of DCLK.
ASDI	5	Input	The AS data input signal is used to transfer data serially into the serial configuration device. It receives the data that should be programmed into the serial configuration device. Data is latched in the rising edge of DCLK.
nCS	1	Input	The active low chip select input signal toggles at the beginning and end of a valid instruction. When this signal is high, the device is deselected and the DATA pin is tri-stated. When this signal is low, it enables the device and puts the device in an active mode. After power up, the serial configuration device requires a falling edge on the nCS signal before beginning any operation.
DCLK	6	Input	DCLK is provided by the FPGA. This signal provides the timing of the serial interface. The data presented on ASDI is latched to the serial configuration device, at the rising edge of DCLK. Data on the DATA pin changes after the falling edge of DCLK and is latched into the FPGA on the rising edge.
VCC	3, 7, 8	Power	Power pins connect to 3.3 V.
GND	4	Ground	Ground pin.

## Package

All serial configuration devices are available in 8-pin or 16-pin plastic SOIC package.



For more information on Altera device packaging including mechanical drawing and specifications for this package, see the *Altera device Package Information Data Sheet*.

## Ordering Code

Table 4–21 shows the ordering codes for serial configuration devices.

<b>Table 4–21. Serial Configuration Device Ordering Codes</b>	
<b>Device</b>	<b>Ordering Code</b>
EPCS1	EPCS1SI8N
EPCS4	EPCS4SI8N
EPCS16	EPCS16SI16N (1)
EPCS64	EPCS64SI16N (1)

**Notes to Table 4–21:**

(1) These devices will not be available until the second half of 2004.