

RM5261

RM5261™ Microprocessor with 64-Bit System Bus

Data Sheet

Proprietary and Confidential

Issue 1, March 2001

Legal Information

Copyright

© 2001 PMC-Sierra, Inc.

The information is proprietary and confidential to PMC-Sierra, Inc., and for its customers' internal use. In any event, you cannot reproduce any part of this document, in any form, without the express written consent of PMC-Sierra, Inc.

PMC-2002241 (R1)

Disclaimer

None of the information contained in this document constitutes an express or implied warranty by PMC-Sierra, Inc. as to the sufficiency, fitness or suitability for a particular purpose of any such information or the fitness, or suitability for a particular purpose, merchantability, performance, compatibility with other parts or systems, of any of the products of PMC-Sierra, Inc., or any portion thereof, referred to in this document. PMC-Sierra, Inc. expressly disclaims all representations and warranties of any kind regarding the contents or use of the information, including, but not limited to, express and implied warranties of accuracy, completeness, merchantability, fitness for a particular use, or non-infringement.

In no event will PMC-Sierra, Inc. be liable for any direct, indirect, special, incidental or consequential damages, including, but not limited to, lost profits, lost business or lost data resulting from any use of or reliance upon the information, whether or not PMC-Sierra, Inc. has been advised of the possibility of such damage.

Trademarks

RM5261 is a trademark of PMC-Sierra, Inc.

Contacting PMC-Sierra

PMC-Sierra, Inc.
105-8555 Baxter Place Burnaby, BC
Canada V5A 4V7

Tel: (604) 415-6000
Fax: (604) 415-6200

Document Information: document@pmc-sierra.com
Corporate Information: info@pmc-sierra.com
Technical Support: apps@pmc-sierra.com
Web Site: <http://www.pmc-sierra.com>

Revision History

Issue No.	Issue Date	ECN Number	Originator	Details of Change
1	March 2001	3828	T. Chapman	Applied PMC-Sierra template to existing MPD (QED) FrameMaker document. Revised Features list, Sections 3.14, 3.19, 3.21, 3.22, 3.23, 3.26, 3.27, 3.30, 3.32, 5, 6, 7, 9.3, 9.4, and packaging diagram information.

Document Conventions

The following conventions are used in this datasheet:

- All signal, pin, and bus names described in the text, such as **ExtRqst***, are in boldface typeface.
- All bit and field names described in the text, such as ***Interrupt Mask***, are in an italic-bold typeface.
- All instruction names, such as MFHI, are in san serif typeface.

Table of Contents

Legal Information	2
Revision History	3
Document Conventions	4
Table of Contents	5
List of Figures	7
List of Tables	8
1 Features	9
2 Block Diagram	10
3 Hardware Overview	11
3.1 Superscalar Dispatch	11
3.2 CPU Registers	11
3.3 Integer Unit	11
3.4 Pipeline	12
3.5 Register File	12
3.6 ALU	12
3.7 Integer Multiply/Divide	13
3.8 Floating-Point Co-Processor	13
3.9 Floating-Point Unit	13
3.10 Floating-Point General Register File	15
3.11 System Control Co-processor (CP0)	15
3.12 System Control Co-Processor Registers	15
3.13 Virtual to Physical Address Mapping	16
3.14 Joint TLB	17
3.15 Instruction TLB	18
3.16 Data TLB	18
3.17 Cache Memory	18
3.18 Instruction Cache	19
3.19 Data Cache	19
3.20 Write buffer	21
3.21 System Interface	21
3.22 System Address/Data Bus	21
3.23 System Command Bus	21
3.24 Handshake Signals	22
3.25 Non-overlapping System Interface	22
3.26 Enhanced Write Modes	23
3.27 External Requests	24
3.28 Interrupt Handling	24
3.29 Standby Mode	24
3.30 JTAG Interface	24

3.31	Boot-Time Options	24
3.32	Boot-Time Modes	25
4	Pin Descriptions	26
5	Absolute Maximum Ratings	29
6	Recommended Operating conditions	30
7	DC Electrical Characteristics	31
8	Power Consumption	32
9	AC Electrical Characteristics	33
9.1	Capacitive Load Deration	33
9.2	Clock Parameters	33
9.3	System Interface Parameters	34
9.4	Boot-Time Interface Parameters	34
10	Timing Diagrams	35
10.1	System Interface Timing	35
11	Packaging Information	36
12	RM5261 208-pin PQFP Package Pinout	38
13	Ordering Information	40

List of Figures

Figure 1	Block Diagram	10
Figure 2	CPU Registers	11
Figure 3	Pipeline	12
Figure 4	CP0 Registers	16
Figure 5	Kernel Mode Virtual Addressing (32-bit)	17
Figure 6	Typical Embedded System Block Diagram	21
Figure 7	Processor Block Read	23
Figure 8	Processor Block Write	23
Figure 9	Clock Timing	35
Figure 10	Input Timing	35
Figure 11	Output Timing	35

List of Tables

Table 1	Integer Multiply/Divide Operations	13
Table 2	Floating-Point Instruction Cycles	14
Table 3	Cache Attributes	20
Table 4	Boot-Time Mode Bit Stream	25
Table 5	System Interface	26
Table 6	Clock/Control Interface	27
Table 7	Interrupt Interface	27
Table 8	JTAG Interface	27
Table 9	Initialization Interface	28
Table 10	Power Supply	28
Table 11	DC Electrical Characteristics	31

1 Features

- Dual Issue superscalar microprocessor
 - 200, 250, 266 MHz operating frequencies
 - 320 Dhrystone 2.1 MIPS
- High-performance system interface
 - 64-bit multiplexed system address/data bus for optimum price/performance
 - High-performance write protocols maximize uncached write bandwidth
 - Processor clock multipliers 2, 2.5, 3, 3.5, 4, 4.5, 5, 6, 7, 8, 9
 - IEEE 1149.1 JTAG boundary scan
- Integrated on-chip caches
 - 32KB instruction and 32KB data — 2 way set associative
 - Virtually indexed, physically tagged
 - Write-back and write-through on a per page basis
 - Pipeline restart on first doubleword for data cache misses
- Integrated memory management unit
 - Fully associative joint TLB (shared by I and D translations)
 - 48 dual entries map 96 pages
 - Variable page size (4 KB to 16 MB in 4x increments)
- High-performance floating-point unit: up to 530 MFLOPS
 - Single cycle repeat rate for common single-precision operations and some double-precision operations
 - Two cycle repeat rate for double-precision multiply and double precision combined multiply-add operations
 - Single cycle repeat rate for single-precision combined multiply-add operation
- MIPS IV instruction set
 - Floating point multiply-add instruction increases performance in signal processing and graphics applications
 - Conditional moves to reduce branch frequency
 - Index address modes (register + register)
- Embedded application enhancements
 - Specialized DSP integer Multiply-Accumulate instructions and 3-operand multiply instruction
 - I and D cache locking by set
 - Optional dedicated exception vector for interrupts
- Fully static 0.25 micron CMOS design with power down logic
 - Standby reduced power mode with WAIT instruction
 - 2.5 V core with 3.3 V IOs
- 208-pin PQFP package

2 Block Diagram

Figure 1 Block Diagram

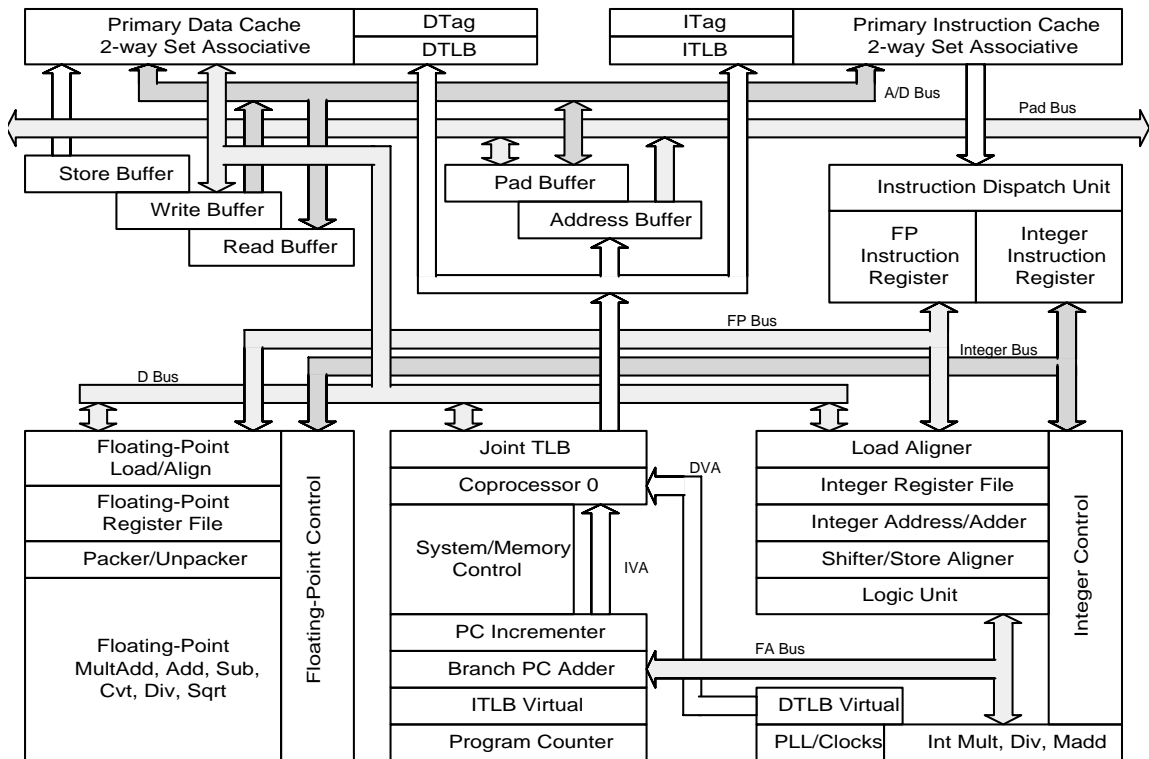

3 Hardware Overview

The RM5261 offers a high-level of integration targeted at high-performance embedded applications. The key elements of the RM5261 are briefly described below.

3.1 Superscalar Dispatch

The RM5261 has an asymmetric superscalar dispatch unit which allows it to issue an integer instruction and a floating-point computation instruction simultaneously. Integer instructions include alu, branch, load/store, and floating-point load/store, while floating-point computation instructions include floating-point add, subtract, combined multiply-add, converts, etc. In combination with its high-throughput fully pipelined floating-point execution unit, the superscalar capability of the RM5261 provides unparalleled price/performance in computationally intensive embedded applications.

3.2 CPU Registers

The RM5261 CPU has a simple user-visible state consisting of 32 general purpose registers, two special purpose registers for integer multiplication and division, a program counter, and no condition code bits. Figure 2 shows the user visible state.

Figure 2 CPU Registers

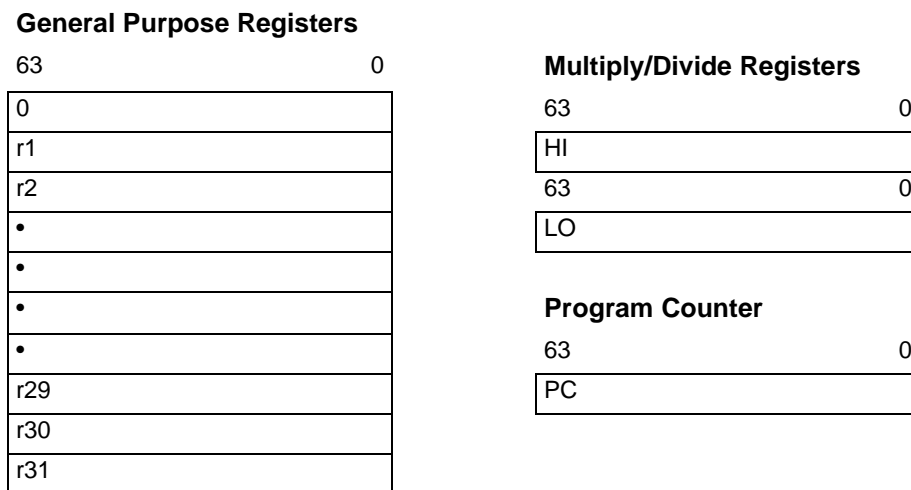

3.3 Integer Unit

Like the RM5260, the RM5261 implements the MIPS IV Instruction Set Architecture, and is therefore fully upward compatible with applications that run on processors implementing the earlier generation MIPS I-III instruction sets. Additionally, the RM5261 includes three implementation specific instructions not found in the baseline MIPS IV ISA but that are useful in the embedded market place. Described in detail in a later section, these instructions are integer multiply-accumulate and 3-operand integer multiply.

The RM5261 integer unit includes thirty-two general purpose 64-bit registers, a load/store architecture with single cycle ALU operations (add, sub, logical, shift) and an autonomous

multiply/divide unit. Additional register resources include: the HI/LO result registers for the two-operand integer multiply/divide operations, and the program counter (PC).

3.4 Pipeline

For integer operations, loads, stores, and other non-floating-point operations, the RM5261 implements a 5-stage integer pipeline. In addition to the integer pipeline, the RM5261 implements an extended 7-stage pipeline for floating-point operations.

The RM5261 multiplies the input SysClock by 2, 2.5, 3, 3.5, 4, 4.5, 5, 6, 7, 8, or 9 to produce the pipeline clock.

Figure 3 shows the RM5261 integer pipeline. As illustrated in the figure, up to five integer instructions can be executing simultaneously.

Figure 3 Pipeline

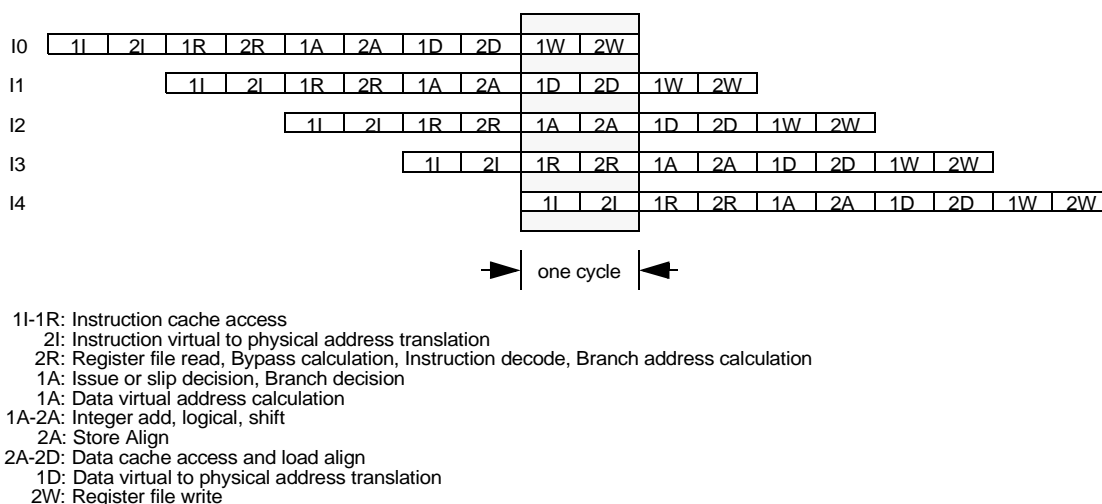

3.5 Register File

The RM5261 has thirty-two general purpose registers with register location 0 (r0) hard-wired to a zero value. These registers are used for scalar integer operations and address calculation. The register file has two read ports and one write port and is fully bypassed to minimize operation latency in the pipeline.

3.6 ALU

The RM5261 ALU consists of an integer adder/subtractor, a logic unit, and a shifter. The adder performs address calculations in addition to arithmetic operations. The logic unit performs all logical and zero shift data moves. The shifter performs shifts and store alignment operations. Each of these units is optimized to perform all operations in a single processor cycle.

3.7 Integer Multiply/Divide

The RM5261 has a dedicated integer multiply/divide unit optimized for high-speed multiply and multiply-accumulate operations. Table 1 shows the performance of the multiply/divide unit on each operation.

Table 1 Integer Multiply/Divide Operations

Opcode	Operand Size	Latency	Repeat Rate	Stall Cycles
MULT/U, MAD/U	16 bit	3	2	0
	32 bit	4	3	0
MUL	16 bit	3	2	1
	32 bit	4	3	2
DMULT, DMULTU	any	7	6	0
DIV, DIVD	any	36	36	0
DDIV, DDIVU	any	68	68	0

The baseline MIPS IV ISA specifies that the results of a multiply or divide operation be placed in the Hi and Lo registers. These values can then be transferred to the general purpose register file using the Move-from-Hi and Move-from-Lo (MFHI/MFLO) instructions.

In addition to the baseline MIPS IV integer multiply instructions, the RM5261 also implements the 3-operand multiply instruction, MUL. This instruction specifies that the multiply result go directly to the integer register file rather than the Lo register. The portion of the multiply that would have normally gone into the Hi register is discarded. For applications where it is known that the upper half of the multiply result is not required, using the MUL instruction eliminates the necessity of executing an explicit MFLO instruction.

Also included in the RM5261 are the multiply-add instructions, MADU/MAD. This instruction multiplies two operands and adds the resulting product to the current contents of the Hi and Lo registers. The multiply-accumulate operation is the core primitive of almost all signal processing algorithms allowing the RM5261 to eliminate the need for a separate DSP engine in many embedded applications.

3.8 Floating-Point Co-Processor

The RM5261 incorporates a high-performance fully pipelined floating-point co-processor which includes a floating-point register file and autonomous execution units for multiply/add/convert and divide/square root. The floating-point coprocessor is a tightly coupled execution unit, decoding and executing instructions in parallel with, and in the case of floating-point loads and stores, in cooperation with the integer unit. The superscalar capabilities of the RM5261 allow floating-point computation instructions to issue concurrently with integer instructions.

3.9 Floating-Point Unit

The RM5261 floating-point execution unit supports single and double precision arithmetic, as specified in the IEEE Standard 754. The execution unit is broken into a separate divide/square root

unit and a pipelined multiply/add unit. Overlap of the divide/square root and multiply/add operations is supported.

The RM5261 maintains fully precise floating-point exceptions while allowing both overlapped and pipelined operations. Precise exceptions are extremely important in object-oriented programming environments and highly desirable for debugging in any environment.

Floating-point operations include:

- add
- subtract
- multiply
- divide
- square root
- reciprocal
- reciprocal square root
- conditional moves
- conversion between fixed-point and floating-point format
- conversion between floating-point formats
- floating-point compare.

Table 2 gives the latencies of the floating-point instructions in internal processor cycles.

Table 2 Floating-Point Instruction Cycles

Operation	Latency	Repeat Rate
fadd	4	1
fsub	4	1
fmult	4/5	1/2
fmadd	4/5	1/2
fmsub	4/5	1/2
fdiv	21/36	19/34
fsqrt	21/36	19/34
frecip	21/36	19/34
frsqrt	38/68	36/66
fcvt.s.d	4	1
fcvt.s.w	6	3
fcvt.s.l	6	3
fcvt.d.s	4	1
fcvt.d.w	4	1
fcvt.d.l	4	1
fcvt.w.s	4	1
fcvt.w.d	4	1
fcvt.l.s	4	1

Operation	Latency	Repeat Rate
fcvt.l.d	4	1
fcmp	1	1
fmov	1	1
fmovc	1	1
fabs	1	1
fneg	1	1

Note: Numbers are represented as single/double precision format.

3.10 Floating-Point General Register File

The floating-point general register file (FGR) is made up of thirty-two 64-bit registers. With the floating-point load and store double instructions (LDC1 and SDC1) the floating-point unit can take advantage of the 64-bit wide data cache and issue a floating-point co-processor load or store doubleword instruction in every cycle.

The floating-point control register space contains two registers; one for determining configuration and revision information for the coprocessor and one for control and status information. These are primarily used for diagnostic software, exception handling, state saving and restoring, and control of rounding modes. To support superscalar operation, the FGR has four read ports and two write ports, and is fully bypassed to minimize operation latency in the pipeline. Three of the read ports and one write port are used to support the combined multiply-add instruction while the fourth read and second write port allows a concurrent floating-point load or store.

3.11 System Control Co-processor (CP0)

The system control coprocessor, also called coprocessor 0 or CP0 in the MIPS architecture, is responsible for the virtual memory sub-system, the exception control system, and the diagnostics capability of the processor. In the MIPS architecture, the system control co-processor (and thus the kernel software) is implementation dependent.

The memory management unit controls the virtual memory system page mapping. It consists of an instruction address translation buffer, ITLB, a data address translation buffer, DTLB, a Joint instruction and data address translation buffer, JTTLB, and co-processor registers used by the virtual memory mapping sub-system.

3.12 System Control Co-Processor Registers

The RM5261 incorporates all system control co-processor (CP0) registers on-chip. These registers provide the path through which the virtual memory system's page mapping is examined and modified, exceptions are handled, and operating modes are controlled (kernel vs. user mode, interrupts enabled or disabled, cache features). In addition, the RM5261 includes registers to implement a real-time cycle counting facility to aid in cache diagnostic testing and to assist in data error detection.

Figure 4 shows the CP0 registers.

Figure 4 CP0 Registers

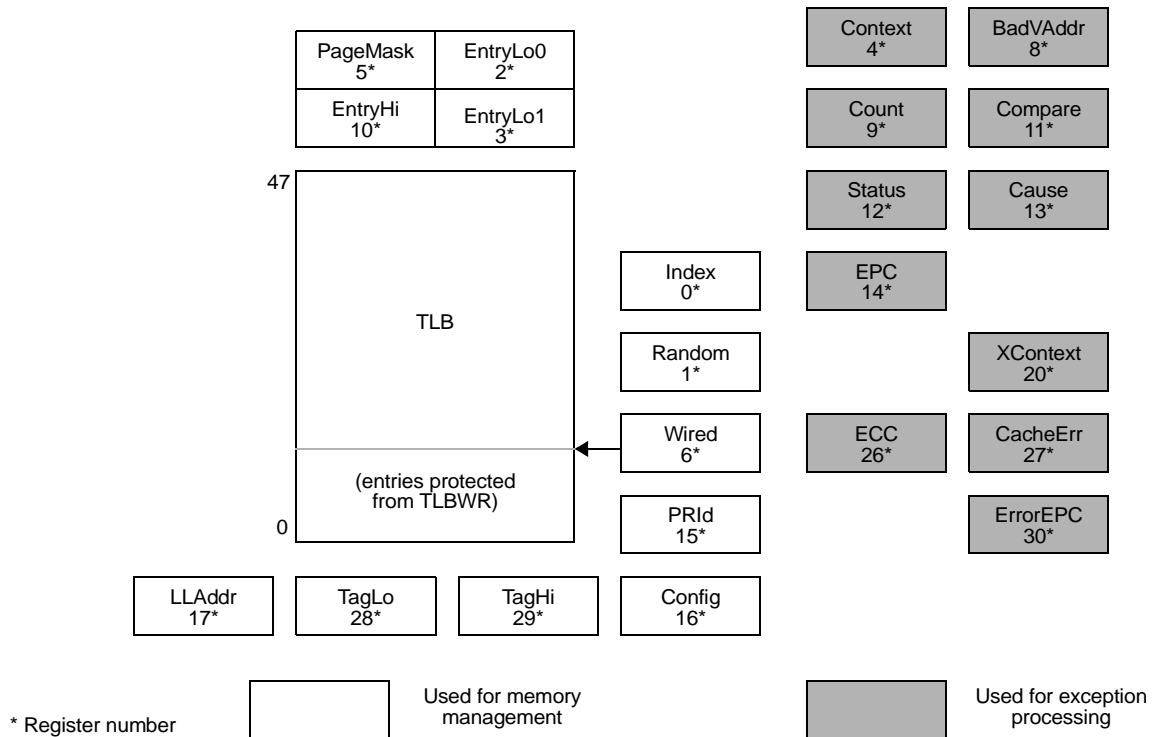

3.13 Virtual to Physical Address Mapping

The RM5261 provides three modes of virtual addressing:

- user mode
- kernel mode
- supervisor mode

This mechanism is available to system software to provide a secure environment for user processes. Bits in the CP0 register Status determine which virtual addressing mode is used. In the user mode, the RM5261 provides a single, uniform virtual address space of 1TB (2 GB in 32-bit mode).

When operating in the kernel mode, four distinct virtual address spaces, totalling over 2.5TB (4 GB in 32-bit mode), are simultaneously available and are differentiated by the high-order bits of the virtual address.

The RM5261 processors also support a supervisor mode in which the virtual address space over 2TB (2.5 GB in 32-bit mode), divided into three regions based on the high-order bits of the virtual address.

When the RM5261 is configured as a 64-bit microprocessor, the virtual address space layout is an upward compatible extension of the 32-bit virtual address space layout.

Figure 5 shows the address space layout for 32-bit operation.

Figure 5 Kernel Mode Virtual Addressing (32-bit)

0xFFFFFFFF	Kernel virtual address space (kseg3)
0xE0000000	Mapped, 0.5GB
0xDFFFFFFF	Supervisor virtual address space (ksegs)
0xC0000000	Mapped, 0.5GB
0xBFFFFFFF	Uncached kernel physical address space (kseg1)
0xA0000000	Unmapped, 0.5GB
0x9FFFFFFF	Cached kernel physical address space (kseg0)
0x80000000	Unmapped, 0.5GB
0x7FFFFFFF	User virtual address space (kuseg)
	Mapped, 2.0GB
0x00000000	

3.14 Joint TLB

For fast virtual-to-physical address translation, the RM5261 uses a large, fully associative TLB that maps 96 virtual pages to their corresponding physical addresses. As indicated by its name, the joint TLB (JTLB) is used for both instruction and data translations. The JTLB is organized as 48 pairs of even-odd entries, and maps a virtual address and address space identifier into the large, 64 GB physical address space.

Two mechanisms are provided to assist in controlling the amount of mapped space and the replacement characteristics of various memory regions. First, the page size can be configured, on a per-entry basis, to use page sizes in the range of 4 KB to 16 MB (in multiples of 4). The CP0 Page Mask register is loaded with the desired page size of a mapping, and that size is stored into the TLB along with the virtual address when a new entry is written. Thus, operating systems can create special purpose maps; for example, an entire frame buffer can be memory mapped using only one TLB entry.

The second mechanism controls the replacement algorithm when a TLB miss occurs. The RM5261 provides a random replacement algorithm to select a TLB entry to be written with a new mapping; however, the processor also provides a mechanism whereby a system specific number of mappings can be locked into the TLB, thereby avoiding random replacement. This mechanism allows the operating system to guarantee that certain pages are always mapped for performance

reasons and for deadlock avoidance. This mechanism also facilitates the design of real-time systems by allowing deterministic access to critical software.

The JTLB also contains information that controls the cache coherency protocol for each page. Specifically, each page has attribute bits to determine whether the coherency algorithm is one of the following:

- uncached
- non-coherent write-back
- non-coherent write-through with write-allocate
- non-coherent write-through without write-allocate
- sharable
- exclusive
- update.

The non-coherent protocols are used for both code and data on the RM5261, with data using write-back or write-through depending on the application.

The coherency attributes generate coherent transaction types on the system interface. However, in the RM5261 cache coherency is not supported. Hence the coherency attributes should never be used.

3.15 Instruction TLB

The RM5261 implements a 2-entry instruction TLB (ITLB) to minimize contention for the JTLB, eliminate the timing critical path of translating through a large associative array, and save power. Each ITLB entry maps a 4 KB page. The ITLB improves performance by allowing instruction address translation to occur in parallel with data address translation. When a miss occurs on an instruction address translation by the ITLB, the least-recently used ITLB entry is filled from the JTLB. The operation of the ITLB is completely transparent to the user.

3.16 Data TLB

The RM5261 implements a 4-entry data TLB (DTLB) for the same reasons cited above for the ITLB. Each DTLB entry maps a 4 KB page. The DTLB improves performance by allowing data address translation to occur in parallel with instruction address translation. When a miss occurs on a data address translation by the DTLB, the DTLB is filled from the JTLB. The DTLB refill is pseudo-LRU: the least recently used entry of the least recently used pair of entries is filled. The operation of the DTLB is completely transparent to the user.

3.17 Cache Memory

The RM5261 incorporates on-chip instruction and data caches that can be accessed in a single processor cycle. Each cache has its own 64-bit data path and both caches can be accessed simultaneously. The cache subsystem provides the integer and floating-point units with an aggregate bandwidth of 3.2 GB per second at an internal clock frequency of 200 MHz.

3.18 Instruction Cache

The RM5261 incorporates a two-way set associative on-chip instruction cache. This virtually indexed, physically tagged cache is 32 KB in size and is protected with word parity.

Since the cache is virtually indexed, the virtual-to-physical address translation occurs in parallel with the cache access, further increasing performance by allowing these two operations to occur simultaneously. The cache tag contains a 24-bit physical address, a valid bit, and a single parity bit.

The instruction cache is 64-bits wide and can be accessed each processor cycle. Accessing 64 bits per cycle allows the instruction cache to supply two instructions per cycle to the superscalar dispatch unit. For typical code sequences where a floating-point load or store and a floating-point computation instruction are being issued together in a loop, the entire bandwidth available from the instruction cache will be consumed.

Cache miss refill writes 64 bits per cycle to minimize the cache miss penalty. The line size is eight instructions (32 bytes) to maximize the performance of communication between the processor and the memory system.

Like the R4650, the RM5261 supports cache locking. The contents of one set of the cache, set A, can be *locked* by setting a bit in the coprocessor 0 Status register. Locking the set prevents its contents from being overwritten by a subsequent cache miss. Refill will occur only into set B. This mechanism allows the programmer to lock critical code into the cache thereby guaranteeing deterministic behavior for the locked code sequence.

3.19 Data Cache

For fast, single cycle data access, the RM5261 includes a 32 KB on-chip data cache that is two-way set associative with a fixed 32-byte (eight words) line size.

The data cache is protected with byte parity and its tag is protected with a single parity bit. It is virtually indexed and physically tagged to allow simultaneous address translation and data cache access.

Cache protocols supported for the data cache are:

1. Uncached

Data loads and instruction fetches from uncached memory space are brought in from the main memory to the register file and the execution unit, respectfully. The caches are not accessed. Data stores to uncached memory space go directly to the main memory without updating the data cache.

2. Write-back

Loads and instruction fetches first search the cache, reading main memory only if the desired data is not cache resident. On data store operations, the cache is first searched to determine if the target address is cache resident. If it is resident, the cache contents are updated, and the cache line is marked for later write-back. If the cache lookup misses, the target cache line is first brought into the cache and then the write is performed as above.

3. Write-through with write allocate

Loads and instruction fetches first search the cache, reading main memory only if the desired data is not cache resident. On data store operations, the cache is first searched to determine if the target address is cache resident. If it is resident, the cache contents are updated and main memory is written, leaving the *write-back* bit of the cache line unchanged. If the cache lookup misses, the target line is first brought into the cache and then the write is performed as above.

4. Write-through without write allocate

Loads and instruction fetches first search the cache, reading main memory only if the desired data is not cache resident. On data store operations, the cache is first searched to determine if the target address is cache resident. If it is resident, the cache contents are updated and main memory is written, leaving the *write-back* bit of the cache line unchanged. If the cache lookup misses, then only main memory is written.

The most commonly used write policy is write-back, where a store to a cache line does not immediately cause the main memory to be updated. This increases system performance by reducing bus traffic and eliminating the bottleneck of waiting for each store operation to finish before issuing a subsequent memory operation. Software can, however, select write-through on a per-page basis when appropriate, such as for frame buffers.

Associated with the data cache is the store buffer. When the RM5261 executes a store instruction, this single-entry buffer gets written with the store data while the tag comparison is performed. If the tag matches, then the data is written into the data cache in the next cycle that the data cache is not accessed (the next non-load cycle). The store buffer allows the RM5261 to execute a store every processor cycle and to perform back-to-back stores without penalty. In the event of a store immediately followed by a load to the same address, a combined merge and cache write occurs such that no penalty is incurred. The RM5261 cache attributes for both the instruction and data caches are summarized in Table 3.

Table 3 Cache Attributes

Characteristics	Instruction	Data
Size	32KB	32KB
Organization	2-way set associative	2-way set associative
Line size	32B	32B
Index	vAddr _{11..0}	vAddr _{11..0}
Tag	pAddr _{31..12}	pAddr _{31..12}
Write policy	n.a.	write-back/write-through
Read order	sub-block	sub-block
Write order	sequential	sequential
miss restart after transfer of	entire line	first double
Parity	per-word	per-byte
Cache locking	set A	set A

3.20 Write buffer

Writes to external memory, whether cache miss write-backs or stores to uncached or write-through addresses, use the on-chip write buffer. The write buffer holds up to four 64-bit address and data pairs. The entire buffer is used for a data cache write-back and allows the processor to proceed in parallel with the memory update. For uncached and write-through stores, the write buffer significantly increases performance by decoupling the **SysAD** bus transfers from the instruction execution stream.

3.21 System Interface

The system interface consists of a 64-bit Address/Data bus with 8 parity check bits and a 9-bit command bus. In addition, there are 6 handshake signals and 6 interrupt inputs. The interface is capable of transferring data between the processor and memory at a peak rate of 800 MB/sec with a 100 MHz SysClock.

Figure 6 shows a typical embedded system using the RM5261. In this example, a bank of DRAMs and a memory controller ASIC share the processor's **SysAD** bus while the memory controller provides separate ports to a boot ROM and an I/O system.

Figure 6 Typical Embedded System Block Diagram

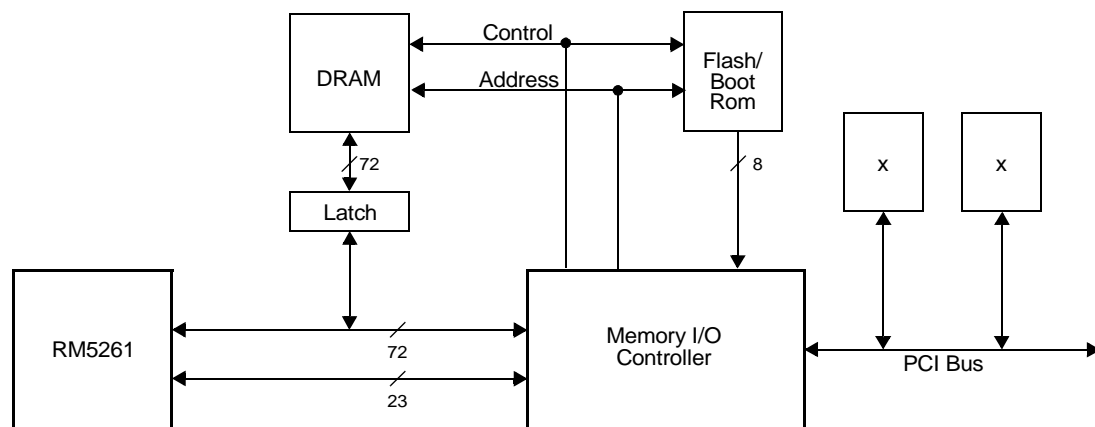

3.22 System Address/Data Bus

The 64-bit System Address Data (**SysAD**) bus is used to transfer addresses and data between the RM5261 and the rest of the system. It is protected with an 8-bit parity check bus (**SysADC**). The system interface is configurable to allow easy interfacing to memory and I/O systems of varying frequencies.

The Block Write data rate, Non-block Write protocol, and Output Drive Strength are programmable at Boot time via the *Mode Control* bits. The rate at which the processor receives data is fully controlled by the external device.

3.23 System Command Bus

The RM5261 interface has a 9-bit System Command (**SysCmd**) bus. The command bus indicates whether the **SysAD** bus carries address or data information on a per-clock basis. If the **SysAD**

carries address, the **SysCmd** bus indicates what type of transaction is to take place (for example, a read or write). If the **SysAD** carries data, the **SysCmd** bus provides information about the data (for example, this is the last data word transmitted, or the data contains an error). The **SysCmd** bus is bidirectional to support both processor requests and external requests to the RM5261. Processor requests are initiated by the RM5261 and responded to by an external device. External requests are issued by an external device and require the RM5261 to respond.

The RM5261 supports one- to eight-byte transfers as well as block transfers on the **SysAD** bus. In the case of a sub-double word transfer, the three low-order address bits give the byte address of the transfer, and the **SysCmd** bus indicates the number of bytes being transferred.

3.24 Handshake Signals

There are six handshake signals on the system interface. Two of these, **RdRdy*** and **WrRdy***, are used by an external device to indicate to the RM5261 whether it can accept a new read or write transaction. The RM5261 samples these signals before deasserting the address on read and write requests.

ExtRqst* and **Release*** are used to transfer control of the **SysAD** and **SysCmd** buses from the processor to an external device. When an external device needs to control the interface, it asserts **ExtRqst***. The RM5261 responds by asserting **Release*** to release the system interface to slave state.

ValidOut* and **ValidIn*** are used by the RM5261 and the external device respectively to indicate that there is a valid address, command or data on the **SysAD** and **SysCmd** buses. The RM5261 asserts **ValidOut*** when it is driving these buses with a valid address, a command or data, and the external device drives **ValidIn*** when it has control of the system interface and is driving a valid address, command or data.

3.25 Non-overlapping System Interface

The RM5261 requires a non-overlapping system interface, compatible with the R5000. This means that only one processor request may be outstanding at a time and that the request must be serviced by an external device before the RM5261 issues another request. The RM5261 can issue read and write requests to an external device, whereas an external device can issue null and write requests to the RM5261.

For processor reads the RM5261 asserts **ValidOut*** and simultaneously drives the address and read command on the **SysAD** and **SysCmd** buses respectively. If the system interface has **RdRdy*** asserted, then the processor tristates its drivers and releases the system interface to the slave state by asserting **Release***. The external device can then begin sending data to the RM5261.

Figure 7 shows a processor block read request and the external agent read response. The read latency is four cycles (**ValidOut*** to **ValidIn***), and the response data pattern is DDDD, indicating that data can be transferred on every clock with no wait states in-between.

Figure 7 Processor Block Read

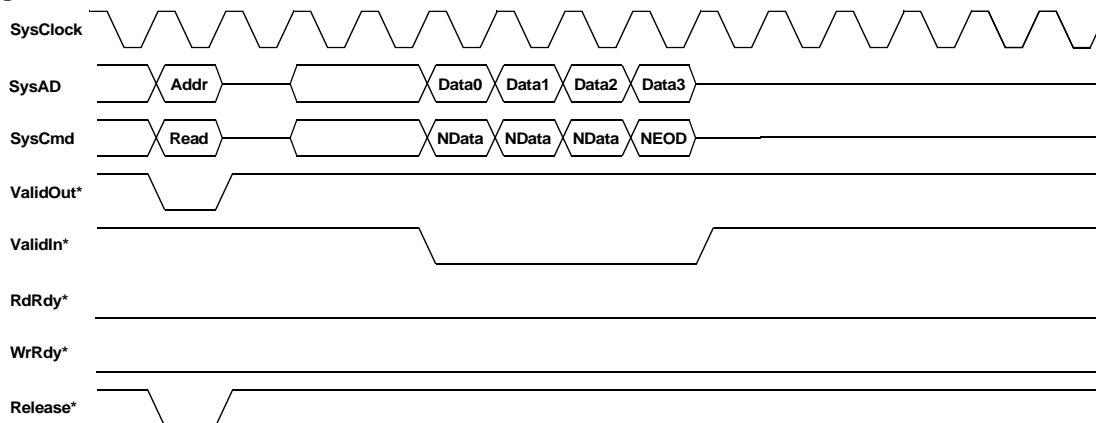
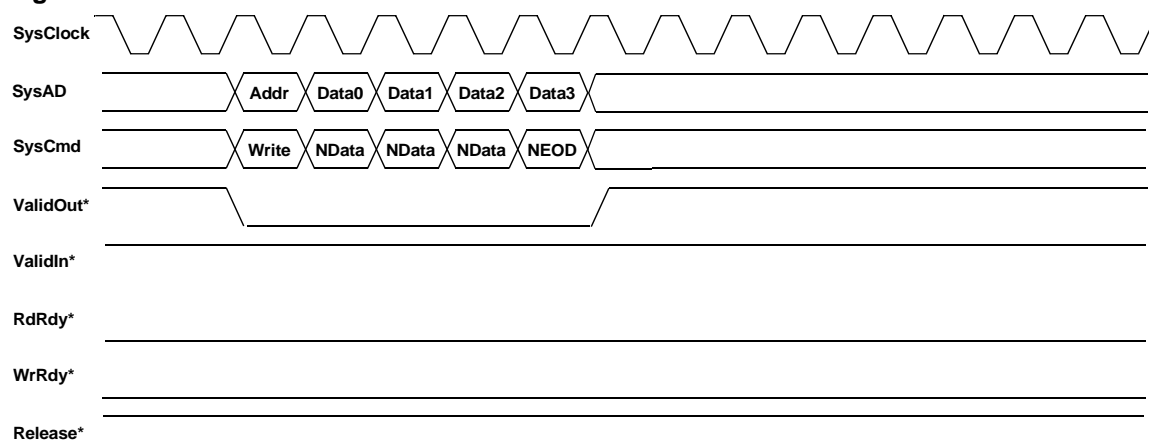

Figure 8 shows a processor block write using write response pattern DDDD, or code 0, of the boot-time mode select options.

Figure 8 Processor Block Write



3.26 Enhanced Write Modes

The RM5231 implements two enhancements to the original R4000 write mechanism: Write Reissue and Pipeline Writes. The original R4000 allowed a write address cycle on the **SysAD** bus only once every four SysClock cycles. Hence for a non-block write, this meant that two out of every four cycles were wait states.

Pipelined write mode eliminates these two wait states by allowing the processor to drive a new write address onto the bus immediately after the previous data cycle. This allows for higher **SysAD** bus utilization. However, at high bus frequencies the processor may drive a subsequent write onto the bus prior to the time the external agent deasserts **WrRdy***, indicating that it can not accept another write cycle. This can cause the write cycle to be missed.

Write reissue mode is an enhancement to pipelined write mode and allows the processor to reissue missed write cycles. If **WrRdy*** is deasserted during the issue phase of a write operation, the cycle is aborted by the processor and reissued at a later time.

In write reissue mode, a write rate of one write every two bus cycles can be achieved. Pipelined writes have the same two bus cycle write repeat rate, but can issue one additional write following the deassertion of **WrRdy***.

3.27 External Requests

The External Request pin, **ExtRqst***, is asserted by the external agent when it requires mastership of the system interface, either to perform an independent transfer or to write to the interrupt register within the RM5261. An independent transfer is a data transfer between two external agents or between an external agent and the memory or peripheral on the system interface. Following the assertion of **ExtRqst***, the RM5261 tri-states its drivers allowing the external agent to use the system interface buses to complete an independent transfer. The external agent is responsible for returning mastership of the system interface to the RM5261 when it has completed the independent transfer and does so by executing an External Null cycle.

3.28 Interrupt Handling

The RM5261 supports a dedicated interrupt vector. When enabled by the real time executive (by setting a bit in the Cause register), interrupts vector to a specific address that is not shared with any of the other exception types. This capability eliminates the need to go through the normal software routine for exception decode and dispatch, thereby lowering interrupt latency.

3.29 Standby Mode

The RM5261 provides a means to reduce the amount of power consumed by the internal core when the CPU would otherwise not be performing any useful operations. This state is known as Standby Mode.

Executing the WAIT instruction enables interrupts and causes the processor to enter Standby Mode. When the wait instruction completes the W pipe stage, and if the **SysAD** bus is currently idle, the internal processor clock stops, thereby freezing the pipeline. The phase lock loop, or PLL, internal timer/counter, and the “wake up” input pins: **Int[5:0]***, **NMI***, **ExtReq***, **Reset***, and **ColdReset*** will continue to operate in their normal fashion. If the **SysAD** bus is not idle when the WAIT instruction completes the W pipe-stage, then the WAIT is treated as a NOP until the bus operation is completed. Once the processor is in Standby, any interrupt, including the internally generated timer interrupt, causes the processor to exit Standby mode and resume operation where it left off. The WAIT instruction is typically inserted in the idle loop of the operating system or real time executive.

3.30 JTAG Interface

The RM5261 interface supports JTAG Test Access Port (TAP) boundary scan in conformance with the IEEE 1149.1 specification. The JTAG interface is especially helpful for checking the integrity of the processors pin connections.

3.31 Boot-Time Options

Fundamental operational modes for the processor are initialized by the boot-time mode control interface. This serial interface operates at a very low frequency (SysClock divided by 256). The low frequency operation allows the initialization information to be kept in a low cost EPROM or system interface ASIC.

Immediately after the **VccOK** signal is asserted, the processor reads a serial bit stream of 256 bits to initialize all the fundamental operational modes. ModeClock run continuously from the assertion of **VccOK**.

3.32 Boot-Time Modes

The boot-time serial mode stream is defined in Table 4. Bit 0 is the bit presented to the processor as the first bit in the stream when **VccOK** is asserted. Bit 255 is the last bit transferred.

Table 4 Boot-Time Mode Bit Stream

Mode bit	Description	Mode bit	Description
0	reserved (must be zero)	14:13	Output driver strength - 100% = fastest 00: 67% strength 01: 50% strength 10: 100% strength 11: 83% strength
4:1	Write-back data rate 0: DDDD 1: DDxDDx 2: DDxxDDxx 3: DxDxDxDx 4: DDxxxDDxxx 5: DDxxxxDDxxxx 6: DxxDxxDxxDxx 7: DDxxxxxxDDxxxxxx 8: DxxxDxxxDxxxDxxx 9-15 reserved	15	Reserved: Must be zero
7:5	Pclock to SysClock Multiplier <u>Mode Bits 7:5</u> <u>Mode Bit 20=0</u> <u>Mode Bit 20=1</u> 000 Multiply by 2 n/a 001 Multiply by 3 n/a 010 Multiply by 4 n/a 011 Multiply by 5 Multiply by 2.5 100 Multiply by 6 n/a 101 Multiply by 7 Multiply by 3.5 110 Multiply by 8 n/a 111 Multiply by 9 Multiply by 4.5	17:16	System configuration identifiers - software visible in Config[21..20] register
8	Specifies byte ordering. Logically ORed with BigEndian input signal. 0: Little endian 1: Big endian	19:18	Reserved: Must be zero
10:9	Non-Block Write Protocol 00: R4000 compatible 01: reserved 10: pipelined 11: write re-issue	20	Select Pclock to SysClock Multiply Mode 0: Integer Multipliers 1: Half-Integer Multipliers
11	Timer Interrupt Enable/Disable 0: Enable the timer interrupt on Int5* 1: Disable the timer interrupt on Int5*	21	External Bus Width 0: 64-bit 1: 32-bit
12	Reserved: Must be zero	255:22	Reserved: Must be zero

4 Pin Descriptions

The following is a list of interface, interrupt, and miscellaneous pins available on the RM5261.

Table 5 System Interface

Pin Name	Type	Description
ExtRqst*	Input	External Request Signals that the system interface is submitting an external request.
Release*	Output	Release interface Signals that the processor is releasing the system interface to slave state.
RdRdy*	Input	Read Ready Signals that an external agent can now accept a processor read.
WrRdy*	Input	Write Ready Signals that an external agent can now accept a processor write request.
ValidIn*	Input	Valid Input Signals that an external agent is now driving a valid address or data on the SysAD bus and a valid command or data identifier on the SysCmd bus.
ValidOut*	Output	Valid Output Signals that the processor is now driving a valid address or data on the SysAD bus and a valid command or data identifier on the SysCmd bus.
SysAD[63:0]	Input/Output	System Address/Data bus A 64-bit address and data bus for communication between the processor and an external agent.
SysADC[7:0]	Input/Output	System Address/Data check bus An 8-bit bus containing parity check bits for the SysAD bus during data cycles.
SysCmd[8:0]	Input/Output	System Command/Data identifier bus A 9-bit bus for command and data identifier transmission between the processor and an external agent.
SysCmdP	Input/Output	Reserved for system command/data identifier bus parity For the RM5261, unused on input and zero on output.

Table 6 Clock/Control Interface

Pin Name	Type	Description
SysClock	Input	System Clock Master clock input used as the system interface reference clock. All output timings are relative to this input clock. Pipeline operation frequency is derived by multiplying this clock up by the factor selected during boot initialization
VccP	Input	Quiet Vcc for PLL Quiet Vcc for the internal phase locked loop. Must be connected to VccInt through a filter circuit.
VssP	Input	Quiet Vss for PLL Quiet Vss for the internal phase locked loop. Must be connected to Vss through a filter circuit.

Table 7 Interrupt Interface

Pin Name	Type	Description
Int[5:0]*	Input	Interrupt Six general processor interrupts, bit-wise ORed with bits 5:0 of the interrupt register.
NMI*	Input	Non-maskable interrupt Non-maskable interrupt, ORed with bit 6 of the interrupt register.

Table 8 JTAG Interface

Pin Name	Type	Description
JTDI	Input	JTAG data in JTAG serial data in.
JTCK	Input	JTAG clock input JTAG serial clock input.
JTDO	Output	JTAG data out JTAG serial data out.
JTMS	Input	JTAG command JTAG command signal, signals that the incoming serial data is command data.

Table 9 Initialization Interface

Pin Name	Type	Description
BigEndian	Input	Allows the system to change the processor addressing mode without rewriting the mode ROM.
VccOK	Input	Vcc is OK When asserted, this signal indicates to the RM5261 that the 3.3V power supply has been above 3.0V for more than 100 milliseconds and will remain stable. The assertion of VccOK initiates the reading of the boot-time mode control serial stream.
ColdReset*	Input	Cold reset This signal must be asserted for a power on reset or a cold reset. ColdReset must be de-asserted synchronously with SysClock.
Reset*	Input	Reset This signal must be asserted for any reset sequence. It may be asserted synchronously or asynchronously for a cold reset, or synchronously to initiate a warm reset. Reset must be de-asserted synchronously with SysClock.
ModeClock	Output	Boot mode clock Serial boot-mode data clock output at the system clock frequency divided by 256.
ModeIn	Input	Boot mode data in Serial boot-mode data input.

Table 10 Power Supply

Pin Name	Type	Description
VccInt	Input	Power supply for core.
VccIO	Input	Power supply for I/O.
Vss	Input	Ground return.

Note

1. An "*" at the end of the signal denotes active low.

5 Absolute Maximum Ratings¹

Symbol	Rating	Limits	Unit
V_{TERM}	Terminal Voltage with respect to V_{SS}	-0.5 ² to +3.9	V
T_{CASE}	Operating Temperature		
	Commercial	0 to +85	°C
	Industrial	-45 to +85	°C
T_{STG}	Storage Temperature	-55 to +125	°C
I_{IN}	DC Input Current	$\pm 20^3$	mA
I_{OUT}	DC Output Current	$\pm 20^4$	mA

Notes

1. Stresses greater than those listed under ABSOLUTE MAXIMUM RATINGS may cause permanent damage to the device. This is a stress rating only and functional operation of the device at these or any other conditions above those indicated in the operational sections of this specification is not implied. Exposure to absolute maximum rating conditions for extended periods may affect reliability.
2. V_{IN} minimum = -2.0 V for pulse width less than 15 ns. V_{IN} should not exceed 3.9 Volts.
3. When $V_{\text{IN}} < 0\text{V}$ or $V_{\text{IN}} > V_{\text{CCIO}}$
4. Not more than one output should be shorted at a time. Duration of the short should not exceed 30 seconds.

6 Recommended Operating conditions

Grade	Temperature	Vss	Vcclnt	VccIO	VccP
Commercial	0°C to +85°C (Case)	0 V	2.5 V ± 5%	3.15 V to 3.45 V	2.5 V ± 5%
Industrial	-40°C to +85°C (Case)	0 V	2.5 V ± 5%	3.15 V to 3.45 V	2.5 V ± 5%

Notes

1. **VccIO** should not exceed **Vcclnt** by greater than 1.2V during the power-up sequence.
2. Applying a logic high state to any I/O pin before **Vcclnt** becomes stable is not recommended.
3. As specified in IEEE 1149.1 (JTAG), the **JTMS** pin must be held high during reset to avoid entering JTAG test mode.
4. **VccP** must be connected to **Vcclnt** through a passive filter circuit. See the RM5200 User's Manual for the recommended filter circuit.

7 DC Electrical Characteristics

Table 11 DC Electrical Characteristics

Parameter	Minimum	Maximum	Conditions
V_{OL}		0.2V	$ I_{OUT} = 100 \mu A$
V_{OH}	$V_{CCIO} - 0.2V$		
V_{OL}		0.4V	$ I_{OUT} = 2 \text{ mA}$
V_{OH}	2.4V		
V_{IL}	-0.3V	0.8V	
V_{IH}	2.0V	$V_{CCIO} + 0.3V$	
I_{IN}		$\pm 15 \mu A$ $\pm 15 \mu A$	$V_{IN} = 0$ $V_{IN} = V_{CCIO}$

8 Power Consumption

Parameter		Conditions: Max: Vcclnt = 2.625 Typ: Vcclnt = 2.5V	CPU Clock Speed					
			200 MHz		250 MHz		266 MHz	
			Typ ¹	Max ²	Typ ¹	Max ²	Typ ¹	Max ²
Vcclnt Power (mWatts)	standby	No SysAD bus activity		350		435		450
	active	R4000 write protocol with no FPU operation	1600	3200	1850	3700	1900	3800
		Write re-issue or pipelined writes with superscalar	1750	3500	2025	4050	2075	4150

Notes

1. Typical integer instruction mix with nominal supply voltage (untested).
2. Worst case instruction mix with maximum supply voltage.
3. I/O supply power is application dependent, but typically <20% of Vcclnt.

9 AC Electrical Characteristics

9.1 Capacitive Load Deration

Parameter	Symbol	Min	Max	Units
Load Derate	C _{LD}		2	ns/25pF
IO Power Derate			21	mW/25pF/MHz
IO Power Derate @ 20pF load		4.0	5.5	mW/MHz

9.2 Clock Parameters

Parameter	Symbol	Test Conditions	CPU Speed						Units
			200 MHz		250 MHz		266 MHz		
			Min	Max	Min	Max	Min	Max	
SysClock High	t _{SCH}	Transition ≤ 5ns	3		3		3		ns
SysClock Low	t _{SCL}	Transition ≤ 5ns	3		3		3		ns
SysClock Frequency ¹			25	100	25	125	33.3	106	MHz
SysClock Period	t _{SCP}			40		40		30	ns
Clock Jitter for SysClock	t _{Jl}			±200		±150		±150	ps
SysClock Rise Time	t _{CR}			2		2		2	ns
SysClock Fall Time	t _{CF}			2		2		2	ns
ModeClock Period	t _{ModeCKP}			256		256		256	t _{SCP}
JTAG Clock Period	t _{JTAGCKP}		4		4		4		t _{SCP}

Note

1. Operation of the RM5261 is only guaranteed with the Phase Lock Loop Enabled.

9.3 System Interface Parameters¹

Parameter	Symbol	Conditions	200–266 MHz		Units
			Min	Max	
Data Output ^{2,3}	t _{DO}	mode14:13 = 10 ⁵ (fastest)	1.0	4.5	ns
		mode14:13 = 11 ⁵	1.0	5.0	ns
		mode14:13 = 00 ⁵	1.0	5.5	ns
		mode14:13 = 01 ⁵ (slowest)	1.0	6.0	ns
Data Setup ⁴	t _{DS}	t _{rise} = see above table	2.5		ns
Data Hold ⁴	t _{DH}	t _{fall} = see above table	1.0		ns

Notes

1. Timings are measured from 1.5 V of the clock to 1.5 V of the signal.
2. Capacitive load for all maximum output timings is 50 pF. Minimum output timings are for a theoretical no load condition - untested.
3. Data Output timing applies to all signal pins whether tristate I/O or output only.
4. Setup and Hold parameters apply to all signal pins whether tristate I/O or input only.
5. Only mode 14:13 = 00 is tested and guaranteed.

9.4 Boot-Time Interface Parameters

Parameter	Symbol	Min	Max	Units
Mode Data Setup	t _{DS(M)}	4		SysClock cycles
Mode Data Hold	t _{DH(M)}	0		SysClock cycles

10 Timing Diagrams

Figure 9 Clock Timing

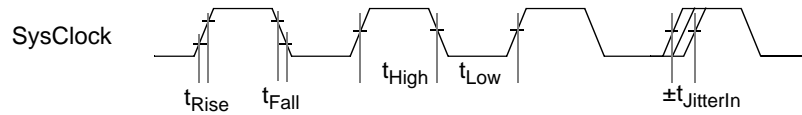

10.1 System Interface Timing

(SysAD, SysCmd, ValidIn*, ValidOut*, etc.)

Figure 10 Input Timing

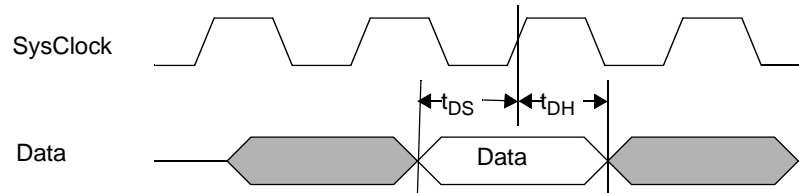
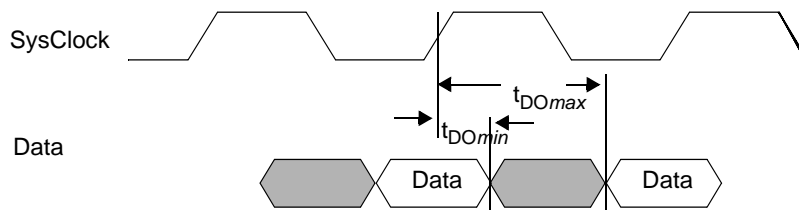
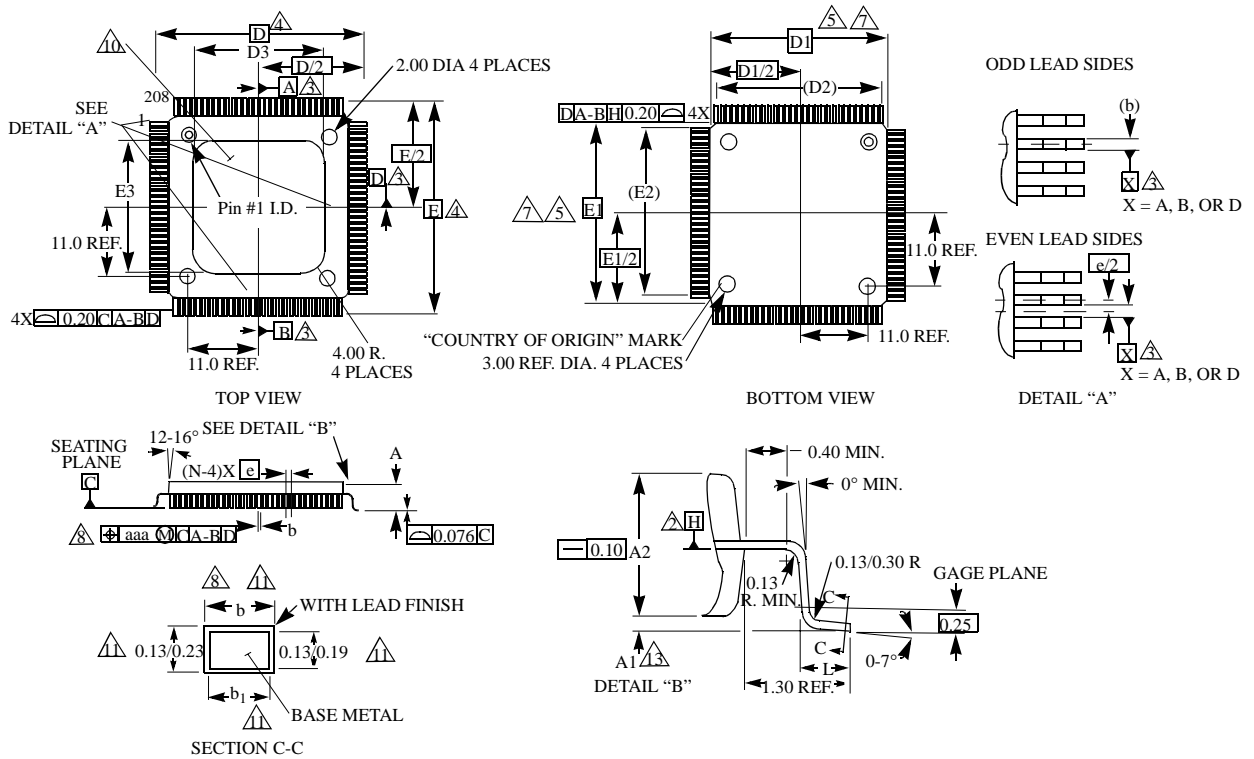

Figure 11 Output Timing



11 Packaging Information



All dimensions are in millimeters unless otherwise noted.

Symbol	208PQ4			Note
	Min	Nominal	Max	
A	--	3.70	4.07	
A1	0.25	0.33	--	
A2	3.20	3.37	3.60	
D	30.60 BSC			To be determined at seating Plane C.
D1	28.00 BSC			Dimensions D1 and E1 do not include mold protrusion. Allowable mold protrusion is 0.254 MM per side. Dimension D1 and E1 do include mold mismatch and are determined at Datum Plane H.
D2	25.00 REF.			
E	30.60 BSC			To be determined at seating Plane C.
E1	28.00 BSC			Dimensions D1 and E1 do not include mold protrusion. Allowable mold protrusion is 0.254 MM per side. Dimension D1 and E1 do include mold mismatch and are determined at Datum Plane H.
E2	25.00 REF.			
D3	21.0 REF.			
E3	21.0 REF.			
L	0.46	0.56	0.66	
e	0.50 BSC			
b	0.17	0.22	0.27	
b1	0.17	0.20	0.23	

Symbol	208PQ4			Note
	Min	Nominal	Max	
aaa	0.08			
ThetaJa	13.7° C/W			
ThetaJc	1.5° C/W			

Notes

1. All dimensioning and tolerances confirm to ASME Y14.5–1994.
2. Datum Plane H located at the bottom of the mold parting line and coincident with where lead exits plastic body.
3. Datums A–B and D to be determined where center line between leads exits plastic body at Datum Plane H.
4. To be determined at seating Plane C.
5. Dimensions D1 and E1 do not include mold protrusion. Allowable mold protrusion is 0.254 MM per side. Dimension D1 and E1 do include mold mismatch and are determined at Datum Plane H.
6. “N” is number of terminals.
7. Package top dimensions are smaller than bottom dimensions by 0.20 millimeters and top of package will not overhang bottom of package.
8. Dimensions b does not include Damabr protrusion. Allowable Damabr protrusion shall be 0.08 MM. Total in excess of b dimension at maximum material condition. Damabr can not be located on the lower radius or the foot. The dimension space between protrusion and an adjacent lead shall not be less than 0.07 MM for 0.4 MM and 0.50 MM pitch package.
9. All dimensions are in millimeters.
10. The optional exposed heat shrink is coincident with the top or bottom side of the package and not allowed to protrude beyond that surface.
11. These dimensions apply to the flat section of the lead between 0.10 MM and 0.25 MM from the lead tip.
12. This drawing conforms to JEDEC registered outline MS-029. But the heat slug dimension was not specified on JEDEC.
13. A1 is defined as the distance from the seating plane to the lowest point of the package body.

12 RM5261 208-pin PQFP Package Pinout

Pin	Function	Pin	Function	Pin	Function	Pin	Function
1	VccIO	2	NC	3	NC	4	VccIO
5	Vss	6	SysAD4	7	SysAD36	8	SysAD5
9	SysAD37	10	VccInt	11	Vss	12	SysAD6
13	SysAD38	14	VccIO	15	Vss	16	SysAD7
17	SysAD39	18	SysAD8	19	SysAD40	20	VccInt
21	Vss	22	SysAD9	23	SysAD41	24	VccIO
25	Vss	26	SysAD10	27	SysAD42	28	SysAD11
29	SysAD43	30	VccInt	31	Vss	32	SysAD12
33	SysAD44	34	VccIO	35	Vss	36	SysAD13
37	SysAD45	38	SysAD14	39	SysAD46	40	VccInt
41	Vss	42	SysAD15	43	SysAD47	44	VccIO
45	Vss	46	ModeClock	47	JTDO	48	JTDI
49	JTCK	50	JTMS	51	VccIO	52	Vss
53	NC	54	NC	55	NC	56	VccIO
57	Vss	58	ModeIn	59	RdRdy*	60	WrRdy*
61	ValidIn*	62	ValidOut*	63	Release*	64	VccP
65	VssP	66	SysClock	67	VccInt	68	Vss
69	VccIO	70	Vss	71	VccInt	72	Vss
73	SysCmd0	74	SysCmd1	75	SysCmd2	76	SysCmd3
77	VccIO	78	Vss	79	SysCmd4	80	SysCmd5
81	VccIO	82	Vss	83	SysCmd6	84	SysCmd7
85	SysCmd8	86	SysCmdP	87	VccInt	88	Vss
89	VccInt	90	Vss	91	VccIO	92	Vss
93	Int0*	94	Int1*	95	Int2*	96	Int3*
97	Int4*	98	Int5*	99	VccIO	100	Vss
101	NC	102	NC	103	NC	104	NC
105	VccIO	106	NMI*	107	ExtRqst*	108	Reset*
109	ColdReset*	110	VccOK	111	BigEndian	112	VccIO
113	Vss	114	SysAD16	115	SysAD48	116	VccInt
117	Vss	118	SysAD17	119	SysAD49	120	SysAD18
121	SysAD50	122	VccIO	123	Vss	124	SysAD19
125	SysAD51	126	VccInt	127	Vss	128	SysAD20
129	SysAD52	130	SysAD21	131	SysAD53	132	VccIO
133	Vss	134	SysAD22	135	SysAD54	136	VccInt
137	Vss	138	SysAD23	139	SysAD55	140	SysAD24
141	SysAD56	142	VccIO	143	Vss	144	SysAD25
145	SysAD57	146	VccInt	147	Vss	148	SysAD26
149	SysAD58	150	SysAD27	151	SysAD59	152	VccIO

Pin	Function	Pin	Function	Pin	Function	Pin	Function
153	Vss	154	NC	155	NC	156	Vss
157	NC	158	NC	159	NC	160	NC
161	VccIO	162	Vss	163	SysAD28	164	SysAD60
165	SysAD29	166	SysAD61	167	VccInt	168	Vss
169	SysAD30	170	SysAD62	171	VccIO	172	Vss
173	SysAD31	174	SysAD63	175	SysADC2	176	SysADC6
177	VccInt	178	Vss	179	SysADC3	180	SysADC7
181	VccIO	182	Vss	183	SysADC0	184	SysADC4
185	VccInt	186	Vss	187	SysADC1	188	SysADC5
189	SysAD0	190	SysAD32	191	VccIO	192	Vss
193	SysAD1	194	SysAD33	195	VccInt	196	Vss
197	SysAD2	198	SysAD34	199	SysAD3	200	SysAD35
201	VccIO	202	Vss	203	NC	204	NC
205	NC	206	NC	207	VccIO	208	Vss

13 Ordering Information

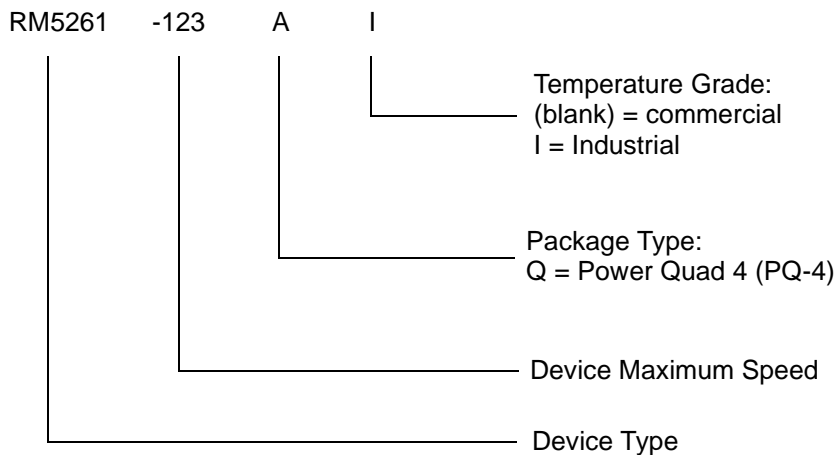

Valid Combinations

RM5261-200-Q

RM5261-250-Q

RM5261-266-Q

RM5261-200-QI (Contact Sales prior to design)