

DUAL PERIPHERAL POSITIVE-NOR DRIVER

DESCRIPTION

The SG55454B/SG55464/SG55474 (SG75454B/SG75464/SG75474) series of dual peripheral Positive-NOR drivers are a family of versatile devices designed for use in systems that employ TTL or DTL logic. This family of drivers are direct replacements for the Texas Instruments SN55454B/64/74 (SN75454B/64/74) series. Diode-clamped inputs simplify circuit design. Typical applications include high-speed logic buffers, power drivers, relay drivers, MOS drivers, line drivers, and memory drivers. The SG55454B/SG55464/SG55474 drivers are characterized for operation over the full military ambient temperature range of -55°C to 125°C and the SG75454B/SG75464/SG75474 drivers are characterized for operation from 0°C to 70°C.

FEATURES

- 300mA output current capability
- High-voltage output
- No output latch-up at 20V
- High speed switching
- TTL or DTL compatible diode-clamped inputs
- Standard supply voltages

HIGH RELIABILITY FEATURES

- SG55454B/SG55464/ SG55474

- ◆ Available to MIL-STD-883
- ◆ Scheduled for MIL-M-38510 QPL listing
- ◆ LMI level "S" processing available

EQUIVALENT CIRCUIT SCHEMATIC (each driver)

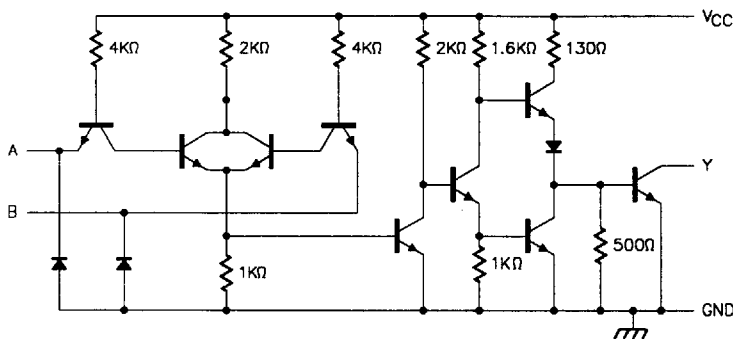

BLOCK DIAGRAM

Positive Logic: $Y = \overline{A + B}$

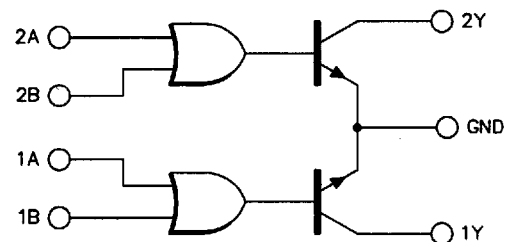

FUNCTION TABLE (each gate)

A	B	Y
L	L	H (off-state)
L	H	L (on-state)
H	L	L (on-state)
H	H	L (on-state)

H = High Level, L = Low Level

SG55454B/64/74 SERIES

ABSOLUTE MAXIMUM RATINGS (Note 1)

Supply Voltage (V_{CC})	7V
Input Voltage	5.5V
Intermitter Voltage	5.5V
Off-state Output Voltage	
X5454B Series	30V
X5464 Series	35V
X5474 Series	70V

Note 1. Exceeding these ratings could cause damage to the device.

Output Current	400mA
Continuous Total Dissipation at (or below)	
25°C Free-Air Temperature	800mW
Operating Junction Temperature	
Hermetic (Y, L Packages)	150°C
Storage Temperature Range	-65°C to 150°C
Lead Temperature (1/16 inch from case for soldering 60 sec.)	300°C

THERMAL DATA

Y Package:

Thermal Resistance-Junction to Case, θ_{JC}	50°C/W
Thermal Resistance-Junction to Ambient, θ_{JA}	130°C/W

L Package:

Thermal Resistance-Junction to Case, θ_{JC}	35°C/W
Thermal Resistance-Junction to Ambient, θ_{JA}	120°C/W

Note A. Junction Temperature Calculation: $T_J = T_A + (P_D \times \theta_{JA})$.

Note B. The above numbers for θ_{JC} are maximums for the limiting thermal resistance of the package in a standard mounting configuration. The θ_{JA} numbers are meant to be guidelines for the thermal performance of the device/pc-board system. All of the above assume no ambient airflow.

RECOMMENDED OPERATING CONDITIONS (Notes 2 & 3)

Supply Voltage (V_{CC})	
SG55454B, SG55464, SG55474	4.5V to 5.5V
SG75454B, SG75464, SG75474	4.75V to 5.25V

Operating Ambient Temperature Range

SG55454B, SG55464, SG55474	-55°C to 125°C
SG75454B, SG75464, SG75474	0°C to 70°C

Note 2. Range over which device is functional.

Note 3. The substrate (pin 8) must always be at the most-negative device voltage for proper operation.

ELECTRICAL CHARACTERISTICS

(Unless otherwise specified, these specifications apply over the operating ambient temperatures for SG55454B/464/474 with $-55^\circ\text{C} \leq T_A \leq 125^\circ\text{C}$, and SG75454B/464/474 with $0^\circ\text{C} \leq T_A \leq 70^\circ\text{C}$. Typical values are tested at $V_{CC} = 5\text{V}$, and $T_A = 25^\circ\text{C}$. Low duty cycle pulse testing techniques are used which maintains junction and case temperatures equal to the ambient temperature.)

Parameter	Test Conditions	SG55454B SG55464 SG55474			SG75454B SG75464 SG75474			Units
		Min.	Typ.	Max.	Min.	Typ.	Max.	
High-level Input Voltage (V_{IH})		2			2			V
Low-level Input Voltage (V_{IL})				0.8			0.8	V
Input Clamp Voltage (V_{IK})	$V_{CC} = \text{MIN}, I_{IN} = -12\text{mA}$		-1.2	-1.5		-1.2	-1.5	V
High-level Output Current (I_{OH})	$V_{CC} = \text{MIN}, V_{IH} = 2\text{V},$ $V_{OH} = 30\text{V SGX5454B}$ $V_{OH} = 35\text{V SGX5464}$ $V_{OH} = 70\text{V SGX5474}$			300			100	μA
Low-level Output Voltage (V_{OL})	$V_{CC} = \text{MIN}, V_{IL} = 0.8\text{V}, I_{OL} = 100\text{mA}$ $V_{CC} = \text{MIN}, V_{IL} = 0.8\text{V}, I_{OL} = 300\text{mA}$		0.25	0.5		0.25	0.4	V
Input Current at Max V_{IN} (I_{IN})	$V_{CC} = \text{MAX}, V_{IN} = 5.5\text{V}$			1.0			1.0	mA
High-level Input Current (I_{IH})	$V_{CC} = \text{MAX}, V_{IN} = 2.4\text{V}$			60			60	μA
Low-level Input Current (I_{IL})	$V_{CC} = \text{MAX}, V_{IN} = 0.4\text{V}$		-1.0	-1.6		-1.0	-1.6	mA
Supply Current, Outputs High	$V_{CC} = \text{MAX}, V_{IN} = 0\text{V}$							
	SGX5454B		13	17		13	17	mA
	SGX5464, SGX5474		14	19		14	19	mA
Supply Current, Outputs Low	$V_{CC} = \text{MAX}, V_{IN} = 5\text{V}$							
	SGX5454B		61	79		61	79	mA
	SGX5464, SGX5474		67	85		67	85	mA

SG55454B/64/74 SERIES

SWITCHING CHARACTERISTICS ($V_{CC} = 5V, T_A = 25^\circ C$)

Parameter	Test Conditions	SG55454B SG75454B			SG55464 SG75464			SG55474 SG75474			Units	
		Min.	Typ.	Max.	Min.	Typ.	Max.	Min.	Typ.	Max.		
Propagation Delay Time, Low-to-High Level Output	$I_C = 200mA, C_L = 15pF, R_L \approx 50\Omega$		26	35		45	110		45	110	ns	
Propagation Delay Time, High-to-Low Level Output			24	35		30	80		30	80	ns	
Transition Time, Low-to-High Output				5	8		13	30		13	30	ns
Transition Time, High-to-Low Level Output				7	12		10	35		10	35	ns
High-Level Output Voltage After Switching (Note 1)	$I_C = 300mA$ $V_S = 20V$ SGX5454B $V_S = 30V$ SGX5464 $V_S = 55V$ SGX5474	$V_S - 6.5$			$V_S - 10$			$V_S - 18$			mV mV mV	

Note 1. These parameters, although guaranteed, are not tested in production.

CONNECTION DIAGRAMS & ORDERING INFORMATION (See Notes Below)

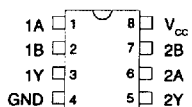
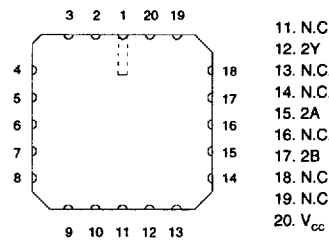
Package	Part No.	Ambient Temperature Range	Connection Diagram
8-PIN CERAMIC DIP Y - PACKAGE	SG55454BY/883B SG55454BY SG55464Y/883B SG55464Y/DESC SG55464Y SG55474Y/883B SG55474YDESC SG55474Y SG75454BY SG75464Y SG75474Y	-55°C to 125°C -55°C to 125°C -55°C to 125°C -55°C to 125°C -55°C to 125°C -55°C to 125°C -55°C to 125°C 0°C to 70°C 0°C to 70°C 0°C to 70°C	
20-PIN CERAMIC LEADLESS CHIP CARRIER L- PACKAGE	SG55454BL/883B SG55454BL/DESC SG55454BL SG55464L/883B SG55464L/DESC SG55464L SG55474L/883B SG55474L/DESC SG55474L	-55°C to 125°C -55°C to 125°C -55°C to 125°C -55°C to 125°C -55°C to 125°C -55°C to 125°C -55°C to 125°C -55°C to 125°C -55°C to 125°C	

- Note 1. Contact factory for JAN and DESC product availability.
 2. All parts are viewed from the top.
 3. Product is also available in flat pack. Consult factory for price and delivery.