

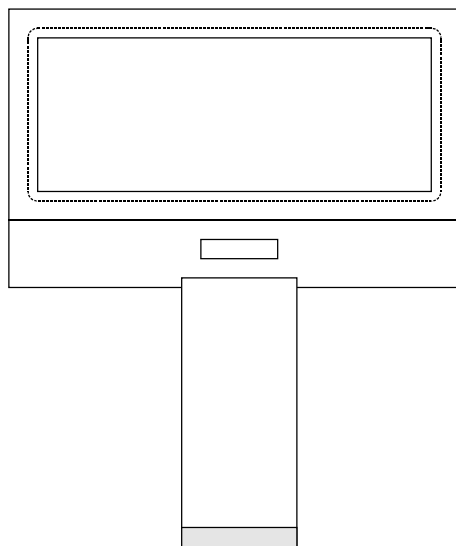

PRODUCT SPECIFICATION

HDG12864F-3

128x64 GRAPHICS
Chip-On-Glass
Parallel Interface
LCD DISPLAY MODULE



HANTRONIX, INC. 10080 BUBB RD. CUPERTINO, CA 95014	Q.A.:	REV.:	HDG12864F-3	SHEET 1 OF 17
	JK	1.0		DATE: 10/17/01

1. MECHANICAL DATA

(1) Product No.	HDG12864F-3
(2) Module Size	71.0 (W)mm x 52.0 (H)mm x 2.8 (D)mm
(3) Dot Size	0.42 (W)mm x 0.51 (H)mm
(4) Dot Pitch	0.46 (W)mm x 0.56 (H)mm
(5) Resolution	128 (W) x 64 (H)
(6) Duty	1/64
(9) LCD Display Mode	FSTN: Normally White / Positive Image
	Rear Polarizer: Reflective
(10) Viewing Direction	6 O'clock
(11) Backlight	Excluded
(12) Weight	22.0 g(Approx.)
(13) Controller	SED1565D0B (S1D15605D00B000)

HANTRONIX, INC. 10080 BUBB RD. CUPERTINO, CA 95014	Q.A.:	REV.:	HDG12864F-3	SHEET 2 OF 17
	JK	1.0		DATE: 10/17/01

2. ABSOLUTE MAXIMUM RATINGS

(1) ELECTRICAL ABSOLUTE RATINGS

VSS=0V

	SYMBOL	MIN	MAX	UNIT	COMMENT
Power Supply for Logic	VDD-VSS	-0.3	5.5	V	
Input Voltage	VI	-0.3	VDD	V	
Static Electricity	-	-	-	-	Note 1

(2) ENVIRONMENTAL ABSOLUTE MAXIMUM RATINGS

ITEM	OPERATING		STORAGE	
	MIN.	MAX.	MIN.	MAX.
Ambient Temperature	-20	70	-30	80
Humidity(Without Condensation)	Note 2,3		Note 2,4	

Note 1 LCM should be grounded during handling LCM.

Note 2 Background color changes slightly depending on ambient temperature.
This phenomenon is reversible.

Note 3 $T_a \leq 70^\circ\text{C}$: 75%RH max
 $T_a > 70^\circ\text{C}$: Absolute humidity must be lower
than the humidity of 75%RH at 70°C

Note 4 T_a at -30°C will be < 48hrs, at 80°C will be < 120hrs

HANTRONIX, INC. 10080 BUBB RD. CUPERTINO, CA 95014	Q.A.:	REV.:	HDG12864F-3	SHEET 3 OF 17
	JK	1.0		DATE:

3. ELECTRICAL CHARACTERISTICS

ITEM	SYMBOL	CONDITION	MIN.	TYP.	MAX.	UNIT	
Power Supply Voltage	VDD	25°C	2.7	3.3	5.5	V	
Input Voltage	VIH	H level	0.7VDD	–	VDD		
	VIO	L level	–0.3	–	0.2VDD		
Recommended LCD Driving Voltage	VDD–VL6 (VLCD)	DUTY= 1/64 Bias= 1/9	–20°C	11.5	11.8	12.1	V
			0°C	11.0	11.3	11.6	
			25°C	10.5	10.8	11.1	
			50°C	10.1	10.4	10.7	
			70°C	9.8	10.1	10.4	
Power Supply Current	IDD	VDD = +5.0v	–	1.7	2.6	mA	

HANTRONIX, INC.
10080 BUBB RD.
CUPERTINO, CA 95014

Q.A.:
JK

REV.:
1.0

HDG12864F-3

SHEET 4 OF 17

DATE:
10/17/01

4. OPTICAL CHARACTERISTICS

AT VOP

ITEM MODE		Cr(Contrast Ratio)										θ (Viewing Angle)		ϕ (Viewing Angle)	
		-20°C		0°C		25°C		50°C		70°C		25°C		25°C	
		MIN.	TYP.	MIN.	TYP.	MIN.	TYP.	MIN.	TYP.	MIN.	TYP.	MIN.	TYP.	MIN.	TYP.
S	J	5.0	7.0	5.0	7.0	5.5	7.5	4.5	6.5	3.0	4.5	-	73	-	±38
NOTE		NOTE 6										NOTE 5			

NOTE :

- S : TRANSFLECTIVE(NORMAL)
- J : NORMALLY WHITE 6 O'CLOCK

AT $\phi=0^\circ$ $\theta=0^\circ$

ITEM	SYMBOL	CONDITION	MIN.	TYP.	MAX.	UNIT	NOTE
Response Time (rise)	Tr	-20°C	2200	2700	3200	ms	NOTE 2
		0°C	450	600	750		
		25°C	150	180	210		
		50°C	65	80	95		
		70°C	40	50	60		
Response Time (fall)	Tf	-20°C	1000	1200	1400	ms	NOTE 2
		0°C	200	250	300		
		25°C	65	80	95		
		50°C	32	40	48		
		70°C	20	25	50		

HANTRONIX, INC. 10080 BUBB RD. CUPERTINO, CA 95014	Q.A.:	REV.:	HDG12864F-3	SHEET 5 OF 17
	JK	1.0		DATE:

(NOTE 1)

Definition of Operation Voltage (Vop)

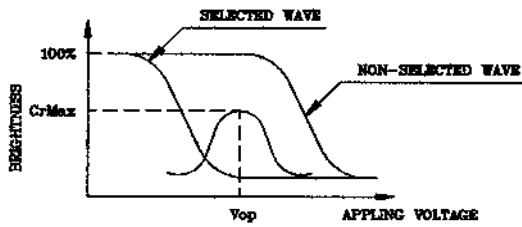

(positive type)

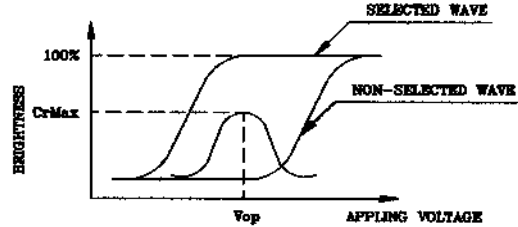

(negative type)

*Conditions

Viewing Angle : 0
 Frame Frequency : 70Hz
 Applying Waveform : 1/N duty 1/a bias

(NOTE 2)

Definition of Response Time (Tr, Tf)

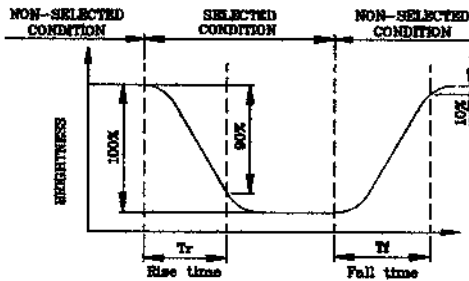

(positive type)

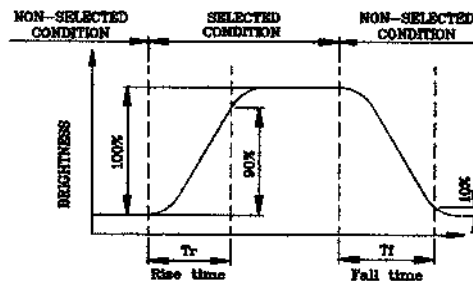

(negative type)

*Conditions

Operating Voltage : Vop
 Viewing Angle (θ,φ) : (0,0)
 Frame Frequency : 70Hz
 Applying Waveform : 1/N duty 1/a bias

(NOTE 3)

Description of Measuring Equipment and Driving Waveforms

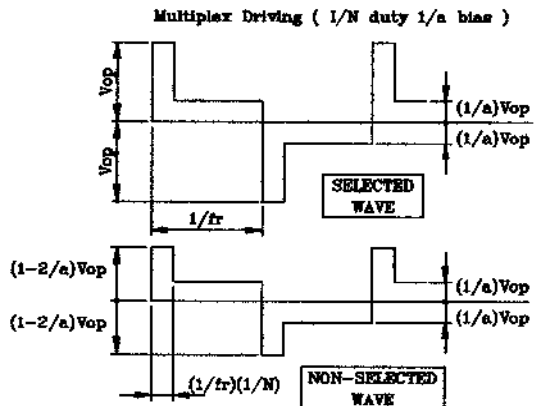
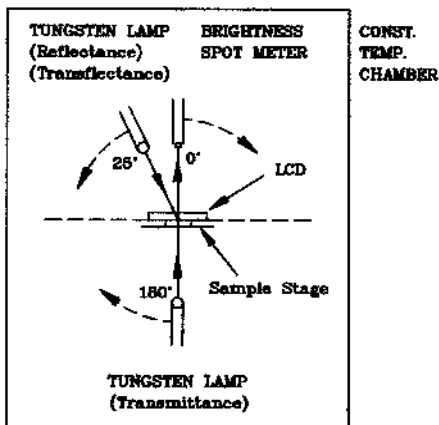

HANTRONIX, INC. 10080 BUBB RD. CUPERTINO, CA 95014	Q.A.:	REV.:	HDG12864F-3	SHEET 6 OF 17
	JK	1.0		DATE:

(NOTE 4)

Definition of Viewing Direction

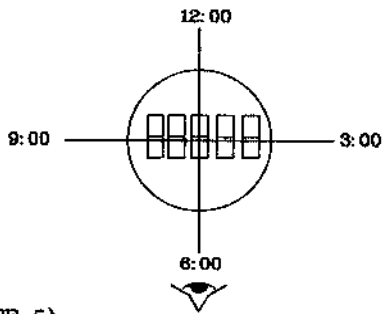

(NOTE 5)

Definition of Viewing Angle

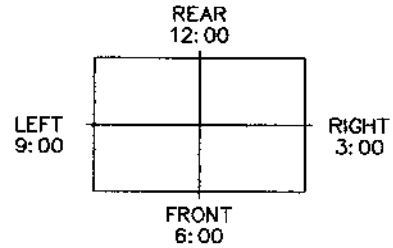
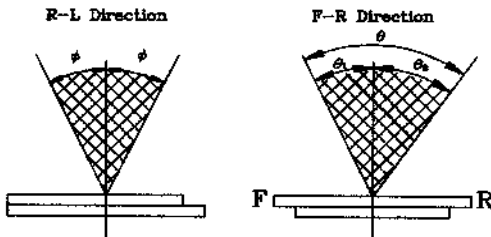

*For This Product
The Viewing Direction Is 6 O'clock
So $\theta_1 > \theta_2$

$$\theta = \theta_1 + \theta_2$$

*Conditions

Operating Voltage : V_{op}
Frame Frequency : 70Hz
Applying Waveform : 1/N duty 1/a bias
Contrast Ratio : larger than 2

(NOTE 6)

Definition of Contrast Ratio (Cr)

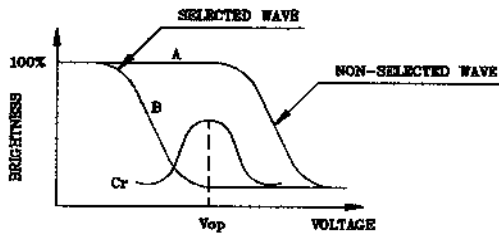

(positive type)

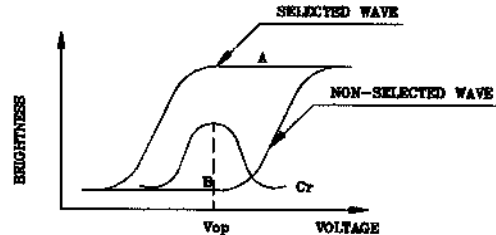

(negative type)

$$\text{Contrast Ratio : } Cr = A/B$$

*Conditions

Viewing Angle : 0
Frame Frequency : 70Hz
Applying Waveform : 1/N duty 1/a bias

HANTRONIX, INC.
10080 BUBB RD.
CUPERTINO, CA 95014

Q.A.:
JK

REV.:
1.0

HDG12864F-3

SHEET 7 OF 17

DATE:
10/17/01

5. BLOCK DIAGRAM

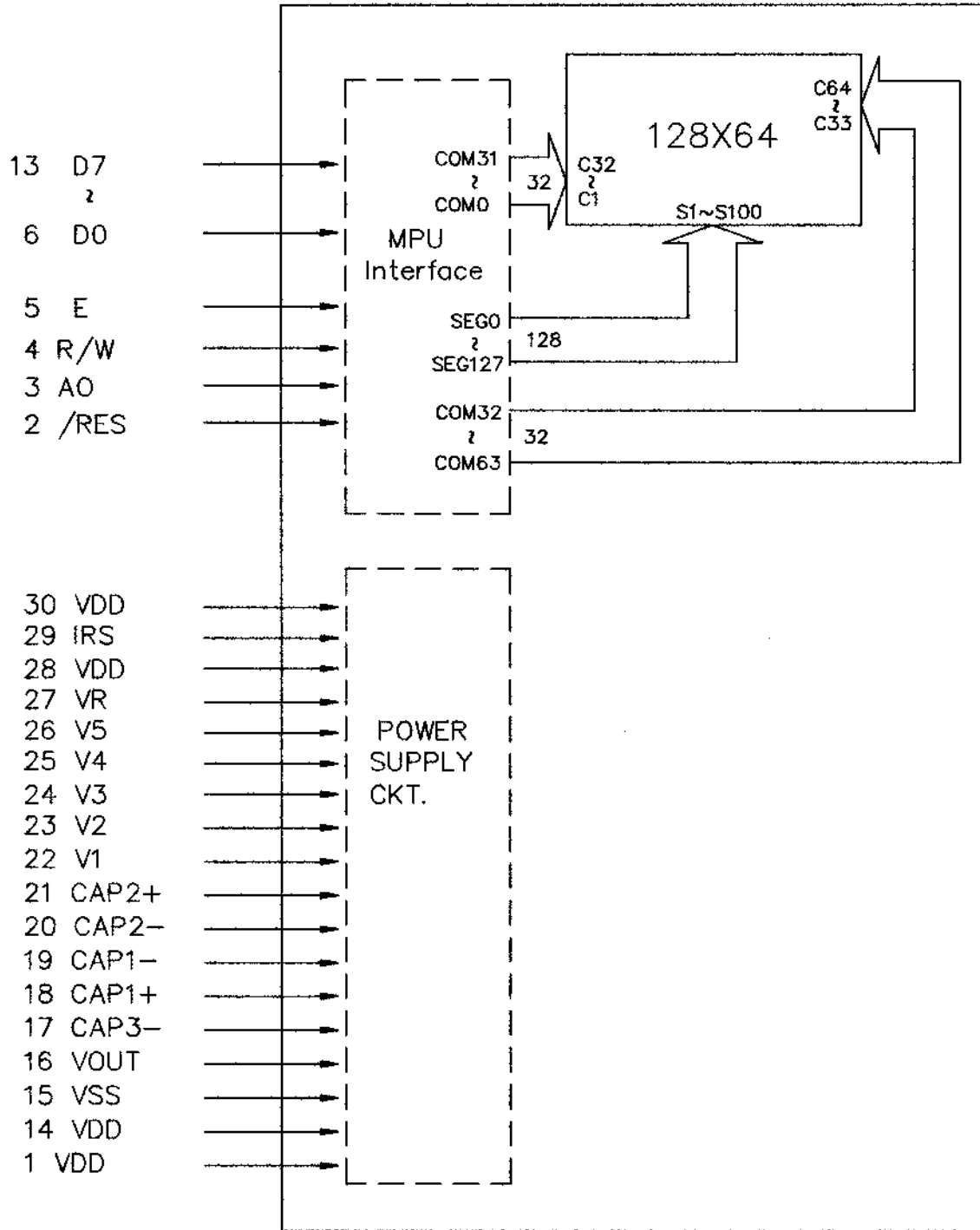

HANTRONIX, INC.
10080 BUBB RD.
CUPERTINO, CA 95014

Q.A.:
JK

REV.:
1.0

HDG12864F-3

SHEET 8 OF 17

DATE:
10/17/01

6. INTERNAL PIN CONNECTION

Pin No.	Symbol	Function
1	VDD	Power Supply for Logic
2	$\overline{\text{RES}}$	Reset Signal
3	A0	Control/Data Select Signal
4	R/W	Signal to Select Read and Write
5	E	Enable Clock Input
6	D0	Data Bus
7	D1	
8	D2	
9	D3	
10	D4	
11	D5	
12	D6	
13	D7	
14	VDD	Power Supply for Logic
15	VSS	Ground
16	Vout	DC/DC Converter Output
17	CAP3--	DC/DC Voltage Converter Capacitor 3 Negative Connection
18	CAP1+	DC/DC Voltage Converter Capacitor 1 Positive Connection
19	CAP1--	DC/DC Voltage Converter Capacitor 1 Negative Connection
20	CAP2--	DC/DC Voltage Converter Capacitor 2 Negative Connection
21	CAP2+	DC/DC Voltage Converter Capacitor 2 Positive Connection
22	V1	LCD Driver Supply Voltages
23	V2	
24	V3	
25	V4	
26	V5	
27	VR	
28	VDD	Power Supply for Logic
29	IRS	"H": Use Internal Resistor ; "L": Not Use Internal Resistor
30	VDD	Power Supply for Logic

Used Cable : FPC , 0.5mm , 30 Pins , thickness 0.3mm.

Mating Connector : Molex 52689-3093 or Compatible.

HANTRONIX, INC. 10080 BUBB RD. CUPERTINO, CA 95014	Q.A.:	REV.:	HDG12864F-3	SHEET 9 OF 17
	JK	1.0		DATE:

7. POWER SUPPLY

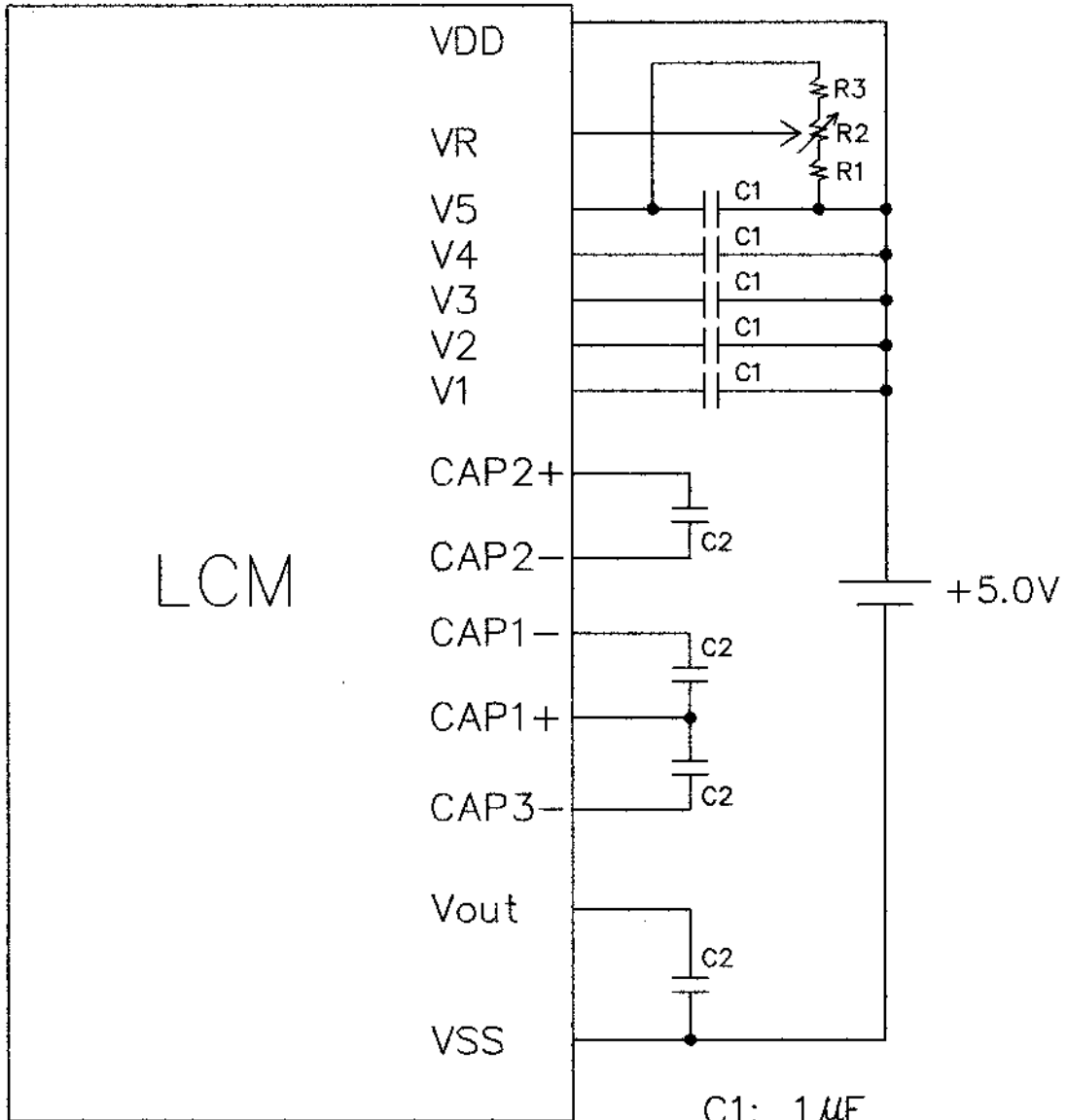

- C1: 1 μ F
- C2: 2.2 μ F
- R1: 240K Ω
- R2: 200K Ω
- R3: 1M Ω

HANTRONIX, INC. 10080 BUBB RD. CUPERTINO, CA 95014	Q.A.:	REV.:	HDG12864F-3	SHEET 10 OF 17
	JK	1.0		DATE:

8. TIMING CHARACTERISTICS

8-1 For 6800 Series MPU

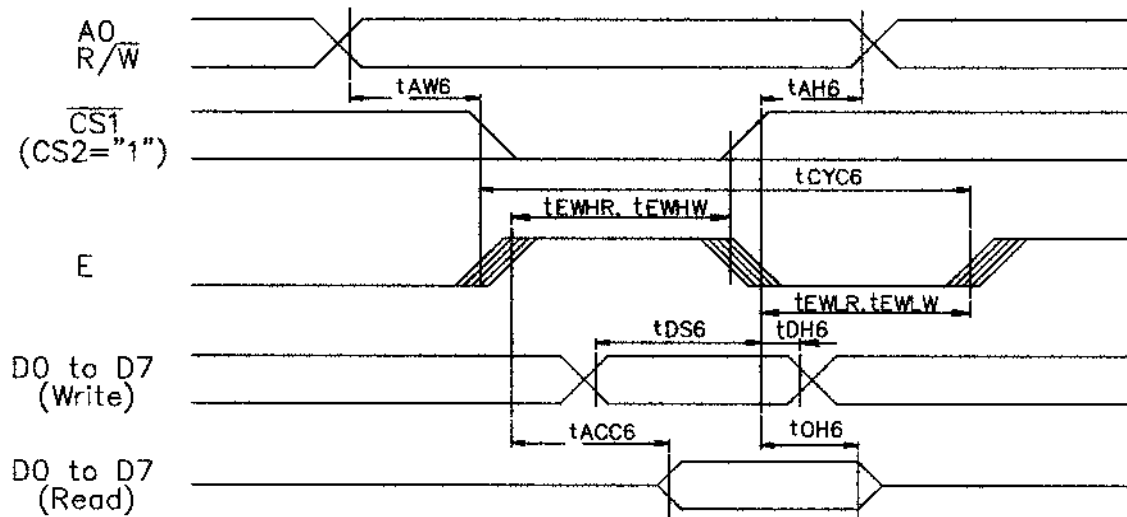

VDD=4.5~5.5V, Ta=-40~85°C

Item	Signal	Symbol	Condition	Rating		Unites
				Min	Max	
Address hold time	A0	tAH6		0	-	ns
Address setup time	A0	tAW6		0	-	ns
System cycle time	A0	tCYC6		166	-	ns
Data setup time	D0 to D7	tDS6		30	-	ns
Data hold time		tDH6		10	-	ns
Access time	D0 to D7	tACC6	CL=100pF	-	70	ns
Output disable time		tOH6		10	50	ns
Enable H pulse time	Read	E	tEWHR	70	-	ns
Write	tEHWLW			30	-	ns
Enable L pulse time	Read	E	tEWLR	30	-	ns
Write	tEWLW			30	-	ns

VDD=2.7~4.5V, Ta=-40~85°C

Item	Signal	Symbol	Condition	Rating		Unites
				Min	Max	
Address hold time	A0	tAH6		0	-	ns
Address setup time	A0	tAW6		0	-	ns
System cycle time	A0	tCYC6		300	-	ns
Data setup time	D0 to D7	tDS6		40	-	ns
Data hold time		tDH6		15	-	ns
Access time	D0 to D7	tACC6	CL=100pF	-	140	ns
Output disable time		tOH6		10	100	ns
Enable H pulse time	Read	E	tEWHR	120	-	ns
Write	tEHWLW			60	-	ns
Enable L pulse time	Read	E	tEWLR	60	-	ns
Write	tEWLW			60	-	ns

8-2 For 8080 Series MPU

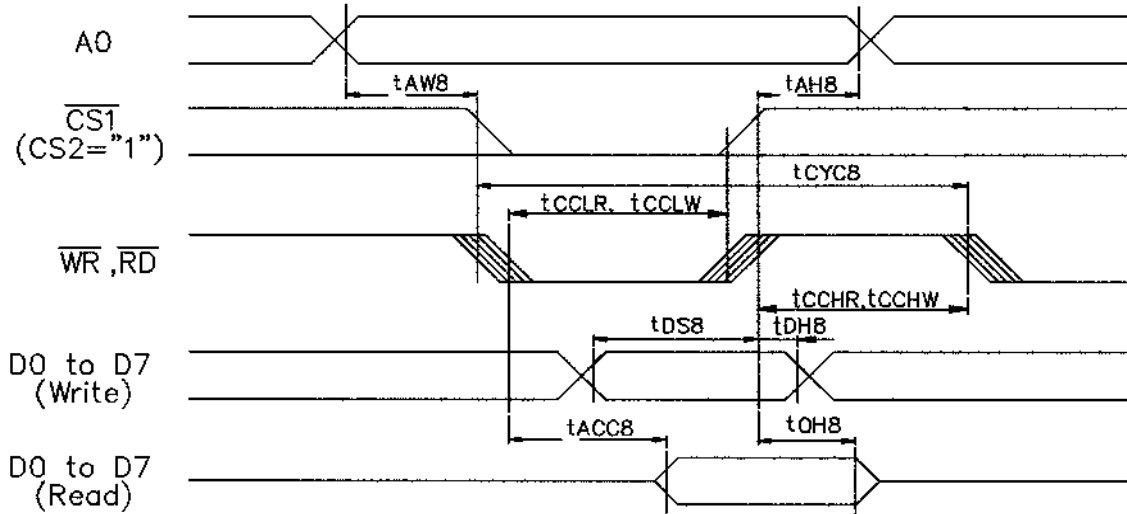

VDD=4.5~5.5V, Ta=-40~85°C

Item	Signal	Symbol	Condition	Rating		Unites
				Min	Max	
Address hold time	A0	tAH8		0	-	ns
Address setup time	A0	tAW8		0	-	ns
System cycle time	A0	tCYC8		166	-	ns
Control L pulse width	WR	tCCLW		30	-	ns
Control L pulse width	RD	tCCLR		70	-	ns
Control H pulse width	WR	tCCHW		30	-	ns
Control H pulse width	RD	tCCHR		30	-	ns
Data setup time		tDHS8		30	-	ns
Data hold time	D0 to D7	tDHS		10	-	ns
RD access time	D0 to D7	tACC8	CL=100pF	-	70	ns
Output disable time	D0 to D7	tOHS		5	50	ns

VDD=2.7~4.5V, Ta=-40~85°C

Item	Signal	Symbol	Condition	Rating		Unites
				Min	Max	
Address hold time	A0	tAH8		0	-	ns
Address setup time	A0	tAW8		0	-	ns
System cycle time	A0	tCYC8		300	-	ns
Control L pulse width	WR	tCCLW		60	-	ns
Control L pulse width	RD	tCCLR		120	-	ns
Control H pulse width	WR	tCCHW		60	-	ns
Control H pulse width	RD	tCCHR		60	-	ns
Data setup time		tDHS8		40	-	ns
Data hold time	D0 to D7	tDHS		15	-	ns
RD access time	D0 to D7	tACC8	CL=100pF	-	140	ns
Output disable time	D0 to D7	tOHS		10	100	ns

HANTRONIX, INC.
10080 BUBB RD.
CUPERTINO, CA 95014

Q.A.:
JK

REV.:
1.0

HDG12864F-3

SHEET 12 OF 17

DATE:
10/17/01

8-3 For Series Interface

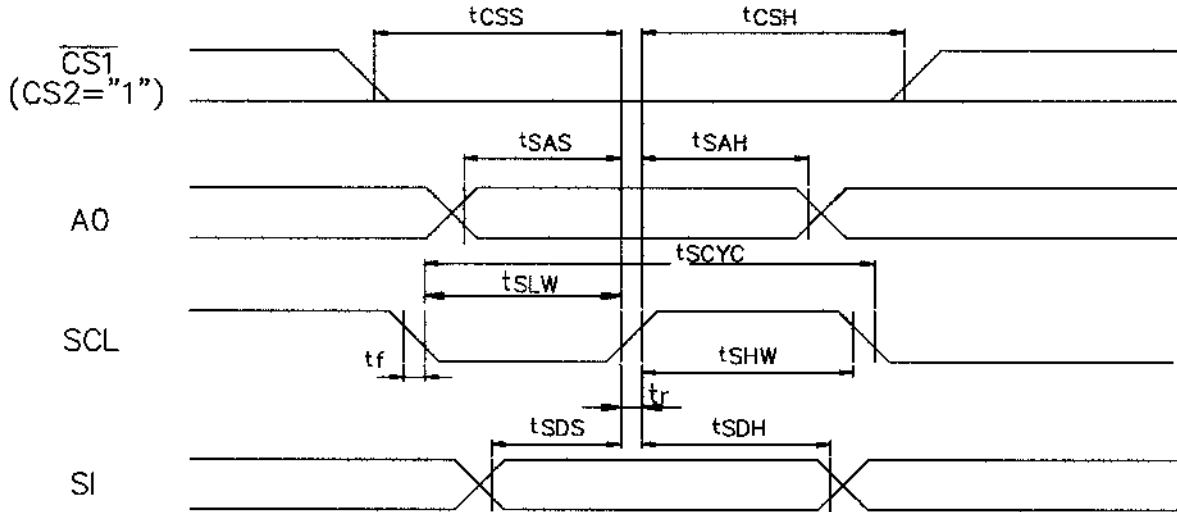

VDD=4.5~5.5V, Ta=-40~85°C

Item	Signal	Symbol	Condition	Rating		Unites
				Min	Max	
Serial Clock Period		tSCYC		200	—	ns
SCL "H" pulse width	SCL	tSHW		75	—	ns
SCL "L" pulse width		tSLW		75	—	ns
Address setup time		tSAS		50	—	ns
Address hold time	A0	tSAH		100	—	ns
Data setup time		tSDS		50	—	ns
Data hold time	SI	tSDH		50	—	ns
CS-SCL time	CS	tCSS		100	—	ns
		tCSH		100	—	ns

VDD=2.7~4.5V, Ta=-40~85°C

Item	Signal	Symbol	Condition	Rating		Unites
				Min	Max	
Serial Clock Period		tSCYC		250	—	ns
SCL "H" pulse width	SCL	tSHW		100	—	ns
SCL "L" pulse width		tSLW		100	—	ns
Address setup time		tSAS		150	—	ns
Address hold time	A0	tSAH		150	—	ns
Data setup time		tSDS		100	—	ns
Data hold time	SI	tSDH		100	—	ns
CS-SCL time	CS	tCSS		150	—	ns
		tCSH		150	—	ns

HANTRONIX, INC.
10080 BUBB RD.
CUPERTINO, CA 95014

Q.A.:

JK

REV.:

1.0

HDG12864F-3

SHEET 13 OF 17

DATE:

10/17/01

8-4 SED1565 Series Commands

Command	Command Code										Function	
	AD	RD	WR	D7	D6	D5	D4	D3	D2	D1		D0
(1)Display ON/OFF	0	1	0	1	0	1	0	1	1	1	0	LCD display ON/OFF 0: OFF,1: ON
(2)Display start line set	0	1	0	0	1	Display start address					Sets the display RAM display start line address	
(3)Page address set	0	1	0	1	0	1	1	Page address				Sets the display RAM page address
(4)Column address set upper bit	0	1	0	0	0	0	1	Most significant column address				Sets the most significant 4 bits of the display RAM column address.
Column address set lower bit	0	1	0	0	0	0	0	Least significant column address				Sets the least significant 4 bits of the display RAM column address.
(5)Status read	0	0	1	Status				0	0	0	0	Reads the status data
(6)Display data write	1	1	0	Write data								Writes to the display RAM
(7)Display data read	1	0	1	Read data								Reads from the display RAM
(8)ADC select	0	1	0	1	0	1	0	0	0	0	0	Sets the display RAM address SEG output correspondence 0: normal,1: reverse
(9)Display normal/reverse	0	1	0	1	0	1	0	0	1	1	0	Sets the LCD display normal/reverse 0: normal,1: reverse
(10)Display all points ON/OFF	0	1	0	1	0	1	0	0	1	0	0	Display all points 0: normal display 1: all point ON
(11)LCD bias set	0	1	0	1	0	1	0	0	0	1	0	Sets the LCD drive voltage bias ratio SED1565***...0:1/9,1:1/7 SED1566***...0:1/8,1:1/6 SED1567***...0:1/6,1:1/5
(12)Read/modify/write	0	1	0	1	1	1	0	0	0	0	0	Column address increment At write: +1 At read: 0
(13)End	0	1	0	1	1	1	0	1	1	1	0	Clear read/modify/write
(14)Reset	0	1	0	1	1	1	0	0	0	1	0	Internal reset
(15)Common output mode select	0	1	0	1	1	0	0	0	*	*	*	Select COM output scan direction 0: normal direction, 1: reverse direction
(16)Power control set	0	1	0	0	0	1	0	1	Operating mode		Select internal power supply operating mode	
(17)V5 voltage regulator internal resistor ratio set	0	1	0	0	0	1	0	0	Resistor ratio		Select internal resistor ratio (Rb/Ra) mode	
(18)Electronic volume mode set	0	1	0	1	0	0	0	0	0	0	1	Set the V5 output voltage electronic volume register
Electronic volume register set	0	1	0	*	*	Electronic volume value						
(19)Static indicator ON/OFF	0	1	0	1	0	1	0	1	1	0	0	0: OFF,1: ON
Static indicator register set	0	1	0	*	*	*	*	*	*	*	mode	Set the flashing mode
(20)Power saver												Display OFF and display all points ON compound command
(21)NOP	0	1	0	1	1	1	0	0	0	1	1	Command for non-operation
(22)Test	0	1	0	1	1	1	1	*	*	*	*	Command for IC test. Do not use this command
(23)Test mode reset	0	1	0	1	1	1	1	0	0	0	0	Enter during the refresh sequence.

(Note)*: disabled data

HANTRONIX, INC. 10080 BUBB RD. CUPERTINO, CA 95014	Q.A.:	REV.:	HDG12864F-3	SHEET 14 OF 17
	JK	1.0		DATE:

9. RELIABILITY TEST

NO	ITEM	CONDITION			STANDARD	NOTE
1	High Temp. Storage	70°C	120HR		Appearance without defect	
2	Low Temp. Storage	-20°C	120HR		Appearance without defect	
3	High Temp. & High Humi. Storage	40°C 90%RH	120HR		Appearance without defect	
4	Thermal Shock	-20°C, 30min → 25°C.5min → 70°C, 30min → 25°C.5min (1cycle)			Appearance without defect	5 cycles

HANTRONIX, INC. 10080 BUBB RD. CUPERTINO, CA 95014	Q.A.:	REV.:	HDG12864F-3	SHEET 15 OF 17
	JK	1.0		DATE: 10/17/01

NOTE:

- SAFETY

- 1.If the LCD panel breaks, be careful not to get the liquid crystal to touch your skin.
- 2.If the liquid crystal touches your skin or clothes, please wash it off immediately by using soap and water.

- HANDLING

- 1.Avoid static electricity which can damage the CMOS LSI.
- 2.Do not remove the panel or frame from the module.
- 3.The polarizing plate of the display is very fragile. So, please handle it very carefully.
- 4.Do not wipe the polarizing plate with a dry cloth, as it may easily scratch the surface of plate.
- 5.Do not use ketonics solvent & Aromatic solvent, use with a soft cloth soaked with a cleaning naphtha solvent.

- STORAGE

- 1.Store the panel or module in a dark place where the temperature is $25^{\circ}\text{C}\pm 5^{\circ}\text{C}$ and the humidity is below 65% RH.
- 2.Do not place the module near organics solvents or corrosive gases.
- 3.Do not crush, shake, or jolt the module.

- TERMS OF WARRANT

- 1.Acceptance inspection period
The period is within one month after the arrival of contracted commodity at the buyer's factory site.
- 2.Applicable warrant period
The period is within twelve months since the date of shipping out under normal using and storage conditions.
- 3.Strengthen Q.C inspection on the light guide, especially the hooks & pinholes.

HANTRONIX, INC. 10080 BUBB RD. CUPERTINO, CA 95014	Q.A.:	REV.:	HDG12864F-3	SHEET 16 OF 17
	JK	1.0		DATE: 10/17/01

Pin No./Symbol	Function
1	VDD Power Supply for Logic
2	RST Reset Signal
3	A0 Control/Data Select Signal
4	R/W Signal to Select Read and Write
5	E Enable Clock Input
6	D0
7	D1
8	D2
9	D3
10	D4
11	D5
12	D6
13	D7
14	VDD Power Supply for Logic
15	VSS Ground
16	Vout DC/DC Converter Output
17	CAP0 DC/DC Voltage Converter Capacitor 0 Negative Connection
18	CAP1+ DC/DC Voltage Converter Capacitor 1 Positive Connection
19	CAP1- DC/DC Voltage Converter Capacitor 1 Negative Connection
20	CAP2 DC/DC Voltage Converter Capacitor 2 Negative Connection
21	CAP2+ DC/DC Voltage Converter Capacitor 2 Positive Connection
22	V1
23	V2
24	V3
25	V4
26	V5
27	VR Voltage Adjustment Pin
28	VDD Power Supply for Logic
29	DS The Internal Resistor : T : 1K4 Use the Internal Resistor
30	VDD Power Supply for Logic

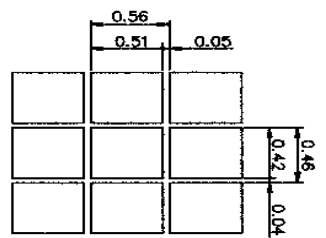
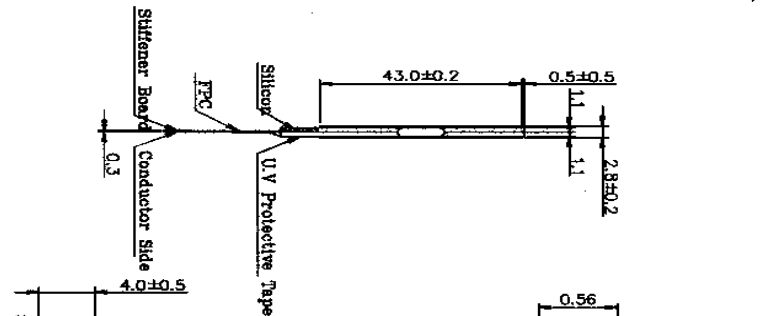
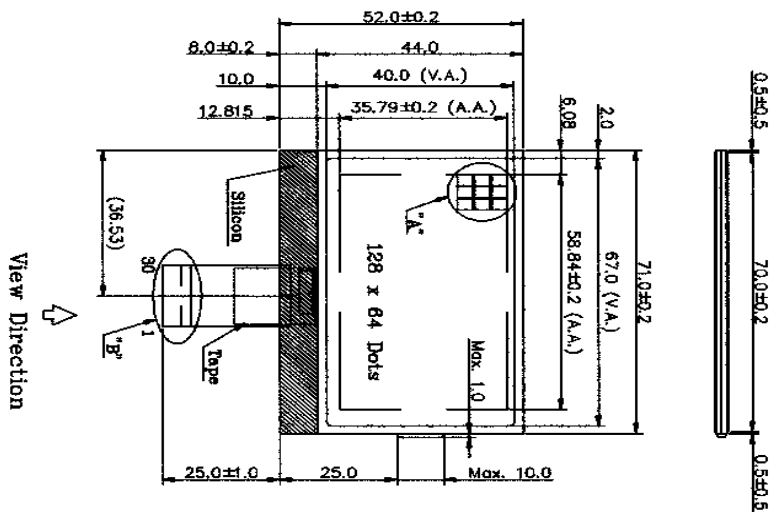

Detail "A"
(Scale 30:1)

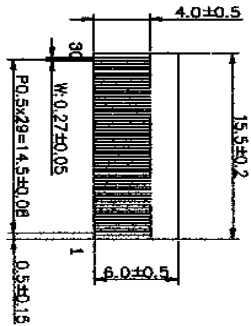

Detail "B"
(Scale 3:1)

GENERAL TOLERANCE LIST	
DIMENSION	TOLERANCE
L ≤ 6	±0.25 (mm)
6 < L ≤ 18	±0.3 (mm)
18 < L ≤ 50	±0.4 (mm)
50 < L ≤ 125	±0.5 (mm)
125 < L	±0.6 (mm)
ANGLE	±1° (DEG)

- Notes :
1. Resolution : 128 x 64 Dots
 2. Controller IC : "EPSON" SED 1565D0B
 3. Thickness of Glass : 1.1mm