

FEATURES

- 3.5% EVM @ $P_{OUT} = +19$ dBm with IEEE 802.11a 64 QAM OFDM at 54 Mbps
- 24.5 dB of Linear Power Gain at 5 GHz
- Single +3.3 V Supply
- 3 mm x 3 mm x 0.9 mm LPCC
- < 1 dB Gain Variation From 4.9 - 5.9 GHz
- 25 dBm P1dB
- 170 mA @ $P_{OUT} = +19$ dBm
- RoHS Compliant
- MSL 1 Rating

APPLICATIONS

- 802.11a WLAN
- 5 GHz Wireless Video Distribution

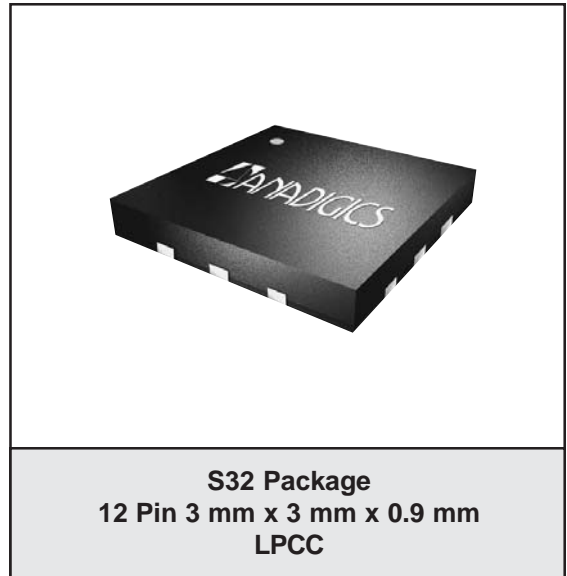

PRODUCT DESCRIPTION

The ANADIGICS RFS P5032 power amplifier is a high performance InGaP HBT power amplifier IC designed for transmit applications in the 4.9-5.9 GHz bands. The PA exhibits unparalleled linearity and efficiency for IEEE 802.11a WLAN systems under the toughest signal configurations within these standards. The PA is biased by a single +3.3 V supply and consumes ultra-low current in the OFF mode.

The RFS P5032 is manufactured using advanced InGaP HBT technology that offers state-of-the-art reliability, temperature stability and ruggedness. The IC is RoHS (Restrictions on Hazardous Substances) compliant, and is provided in a 3 mm x 3 mm x 0.9 mm LPCC package optimized for a 50 Ω system.

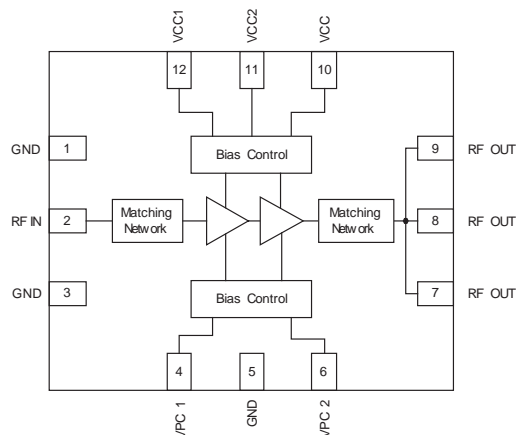

Figure 1: Block Diagram and Pinout

Table 1: Pin Description

PIN	NAME	DESCRIPTION
1	GND	Ground. Connect directly to PCB ground pattern under IC using the shortest possible path.
2	RF _{IN}	RF Input. RF input to power amplifier matched to 50 Ω. Route as coplanar waveguide using adjacent ground pins. RF input can be optimally impedance matched with shunt capacitor. Application circuit shows stub capacitor.
3	GND	Ground. Connect directly to PCB ground pattern under IC using the shortest possible path.
4	V _{PC1}	Power Control. Power amplifier bias control pin for stage 1. The recommended use is for on/off control of the PA. Nominally, 0 V applied will turn amplifier completely off; +3.3 V should be used to set amplifier to maximum output capability. At maximum output power capability, this pin will draw approximately 1 to 2 mA of current. A series resistor is used to set the current flow into the pin, thereby controlling the overall bias level of the PA.
5	GND	Ground. Connect directly to PCB ground pattern under IC using the shortest possible path.
6	V _{PC2}	Power Control. Power amplifier bias control pin for stage 2. The recommended use is for on/off control of the PA. Nominally, 0 V applied will turn amplifier completely off; +3.3 V should be used to set amplifier to maximum output capability. At maximum output power capability, this pin will draw as much as 1 to 2 mA of current. A series resistor is used to set the current flow into the pin, therefore setting overall bias level of the PA.
7,8,9	RF _{OUT}	RF Output. RF output of power amplifier can be optimally impedance matched with additional shunt capacitor enabling maximum linearity. Application circuit shows stub capacitor. This pin is also used to bias the 3rd stage power transistor through an RF choke inductor.
10	V _{CC}	Supply Voltage. Main Bias feed for bias control circuitry on all stages.
11	V _{CC2}	Supply Voltage. Bias for power transistor of stage 2. Typically set to +3.3 V.
12	V _{CC3}	Supply Voltage. Bias for power transistor of stage 1. Typically set to +3.3 V.

ELECTRICAL CHARACTERISTICS

Table 2: Absolute Minimum and Maximum Ratings

PARAMETER	MIN	MAX	UNIT	COMMENTS
DC Power Supply (V_{CC}, V_{CC1}, V_{CC2})	-	+4.0	V	
Power Control Level (V_{PC1}, V_{PC2})	-	+4.0	V	Applied to series resistors external to V_{PC} pins. No RF signal applied.
DC Current Consumption	-	700	mA	
RF Input Level (RF_{IN})	-	0	dBm	
Operating Ambient Temperature	-40	+85	°C	
Storage Temperature	-55	+150	°C	

Stresses in excess of the absolute ratings may cause permanent damage. Functional operation is not implied under these conditions. Exposure to absolute ratings for extended periods of time may adversely affect reliability.

Table 3: Operating Ranges

PARAMETER	MIN	TYP	MAX	UNIT	COMMENTS
Operating Frequency (f)	4900	-	5900	MHz	802.11a
Supply Voltage (V_{CC}, V_{CC1}, V_{CC2})	+3.0	+3.3	+3.6	V	
Power Control Voltage (V_{PC})	+2.8 0	+3.3 -	+3.6 +0.5	V	PA "ON" ⁽¹⁾ PA "SHUTDOWN" ⁽¹⁾
Case Temperature (T_C)	-40	-	+85	°C	

The device may be operated safely over these conditions; however, parametric performance is guaranteed only over the conditions defined in the electrical specifications.

Note:

(1) Applied to series resistors external to V_{PC} pins.

Table 4: Electrical Specifications - Continuous Wave
(T_c = +25 °C, V_{CC} = +3.3 V, V_{PC} = +3.3 V)

PARAMETER	MIN	TYP	MAX	UNIT	COMMENTS
P1dB	24	25	-	dBm	
Shutdown Current	-	-	5	μA	5 GHz Bias = 0 V
Quiescent Current	77	85	93	mA	V _{PC} = +3.3 V, V _{CC} = +3.3 V, RF = Off
Input Return Loss	-	-15	-10	dB	with application circuit
Output Return Loss	-	-15	-10	dB	with application circuit
Reverse Isolation	30	40	-	dB	
Stability (Spurious)	-	-65	-60	dBc	6:1 VSWR, P _{OUT} = +22 dBm; -40 °C

Table 5: Electrical Specifications - IEEE 802.11a
(T_c = +25 °C, V_{CC} = +3.3 V, V_{PC} = +3.3 V, 64 QAM OFDM 54 Mbps)

PARAMETER	MIN	TYP	MAX	UNIT	COMMENTS
Operating Frequency	4900	-	5900	MHz	
Power Gain	23.5	24.5	25.5	dB	P _{OUT} = +19 dBm
Gain Ripple	-	± 0.5	-	dB	Across any 100 MHz band
Error Vector Magnitude (EVM) ⁽¹⁾	-	3.5	4.5	%	P _{OUT} = +19 dBm, 4.90 - 5.35 GHz 802.11a 54 Mbps data rate
	-	-29	-27	dB	
	-	4.5	5.5	%	P _{OUT} = +19 dBm, 5.35 - 5.85 GHz 802.11a 54 Mbps data rate
	-	-27	-25	dB	
Current Consumption	160	170	180	mA	P _{OUT} = +19 dBm
Harmonics					
2fo	-	-40	-35	dBc	P _{OUT} = +20 dBm
3fo	-	-40	-35		

Note:

(1) EVM includes system noise floor of 1% (-40 dB).

PERFORMANCE DATA

Figure 2: Gain, I_{cc} and EVM vs. Output Power Across Frequency (V_{cc} = +3.3V, T_c = +25°C)
802.11a 54 Mbps OFDM

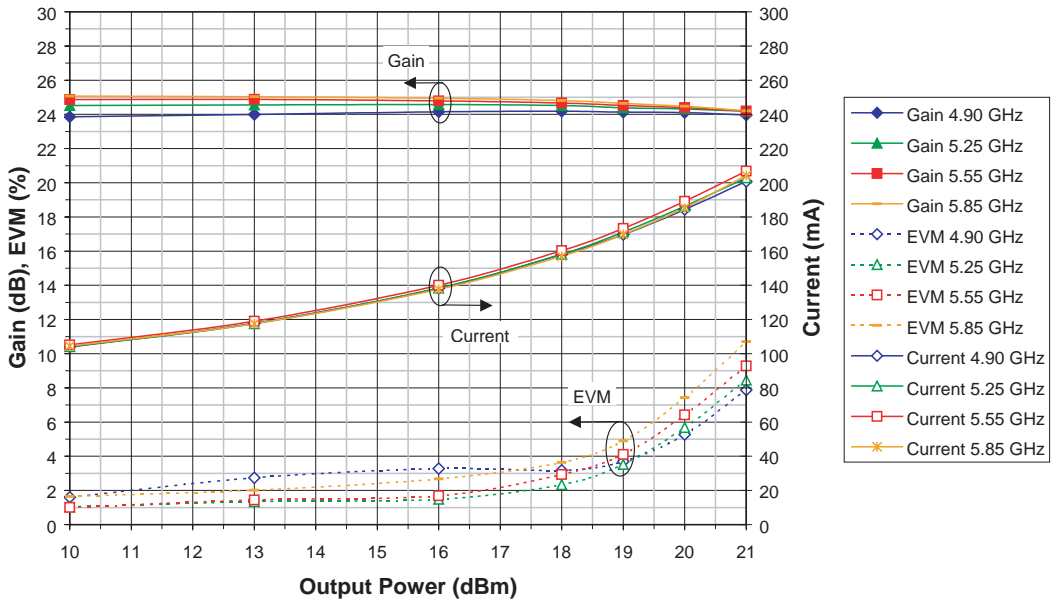

Figure 3: Gain, I_{cc} and EVM vs. Output Power Across Power Supply Voltage (Freq = 5.25GHz, T_c = +25°C)
802.11a 54 Mbps OFDM

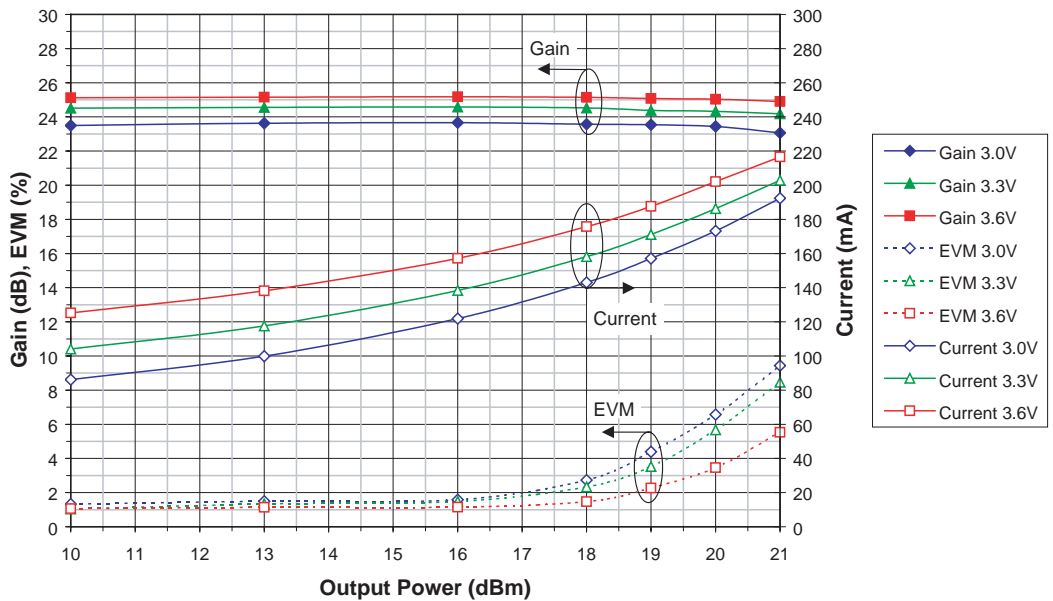

Figure 4: Gain, I_{cc} and EVM vs. Output Power Across Temperature (Freq = 5.25 GHz, V_{cc} = +3.3 V)
802.11a 54 Mbps OFDM

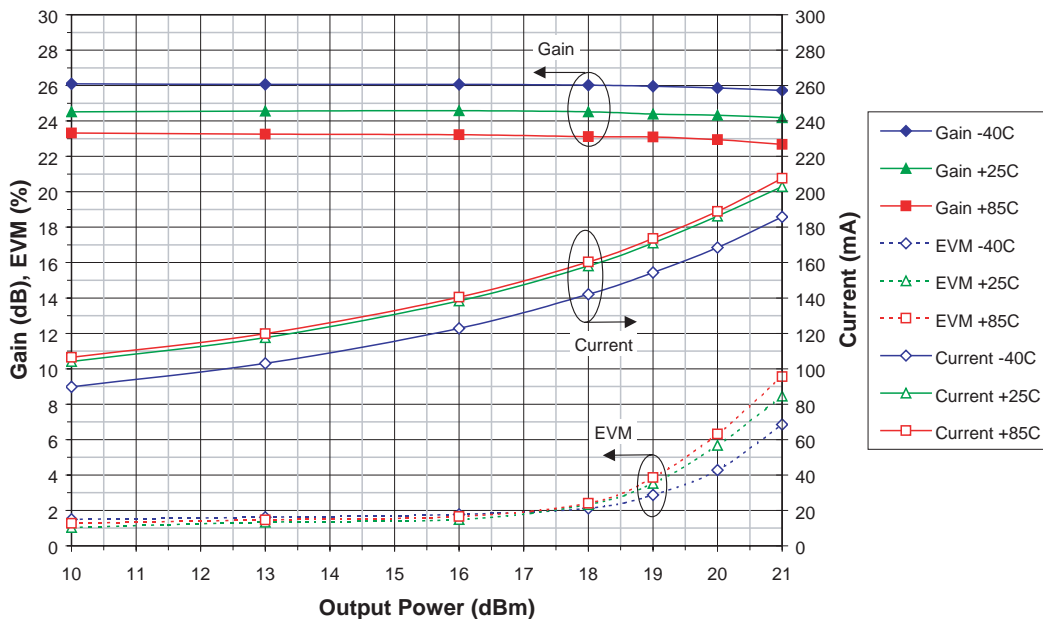

Figure 5: Input Return Loss vs. Frequency Across Temperature (V_{cc} = +3.3 V)

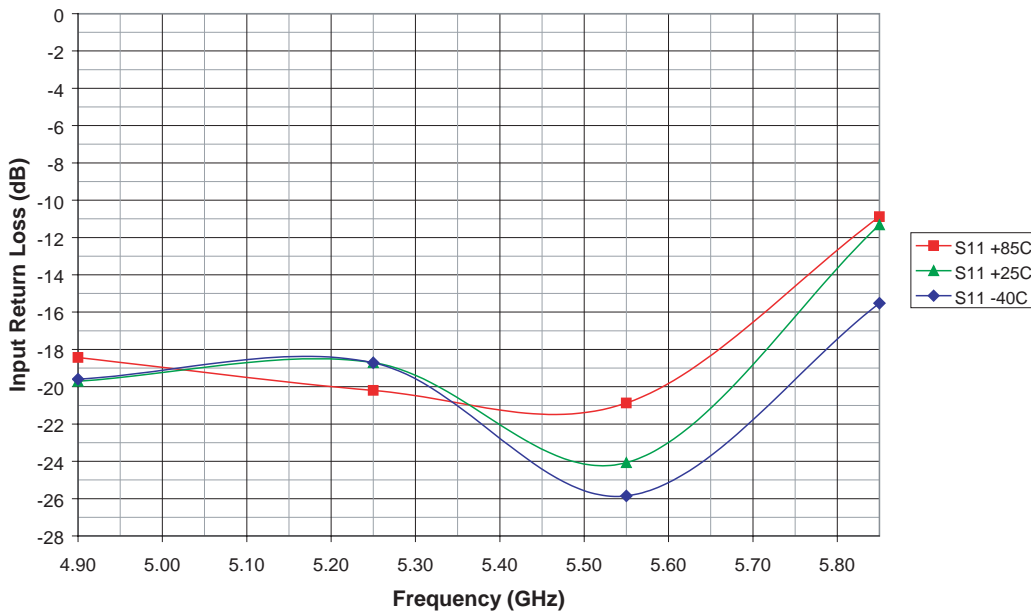
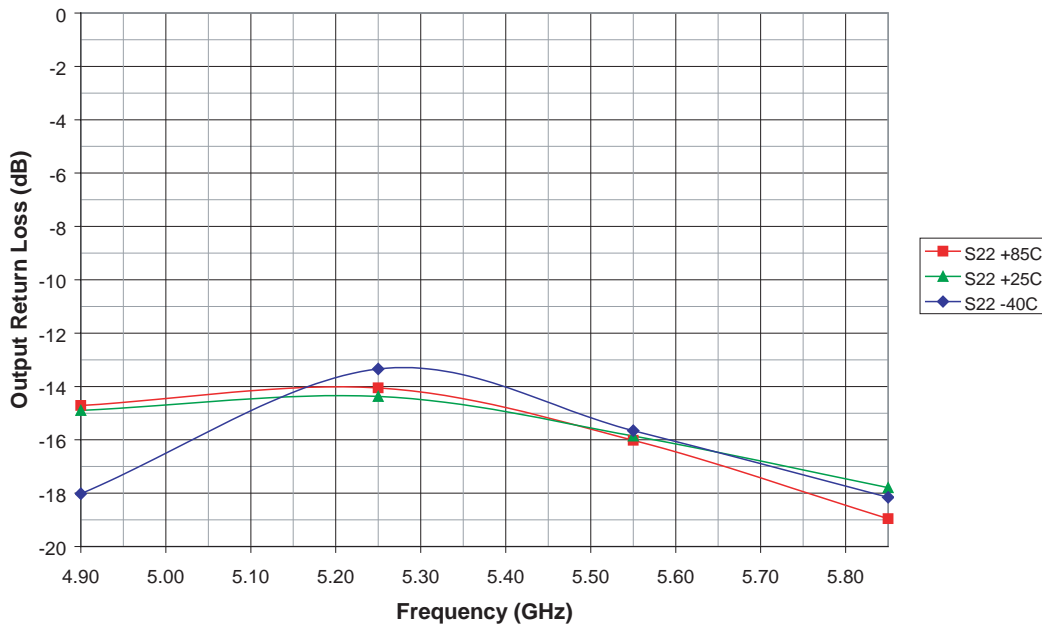

Figure 6: Output Return Loss vs. Frequency Across Temperature ($V_{CC} = +3.3\text{ V}$)



APPLICATION INFORMATION

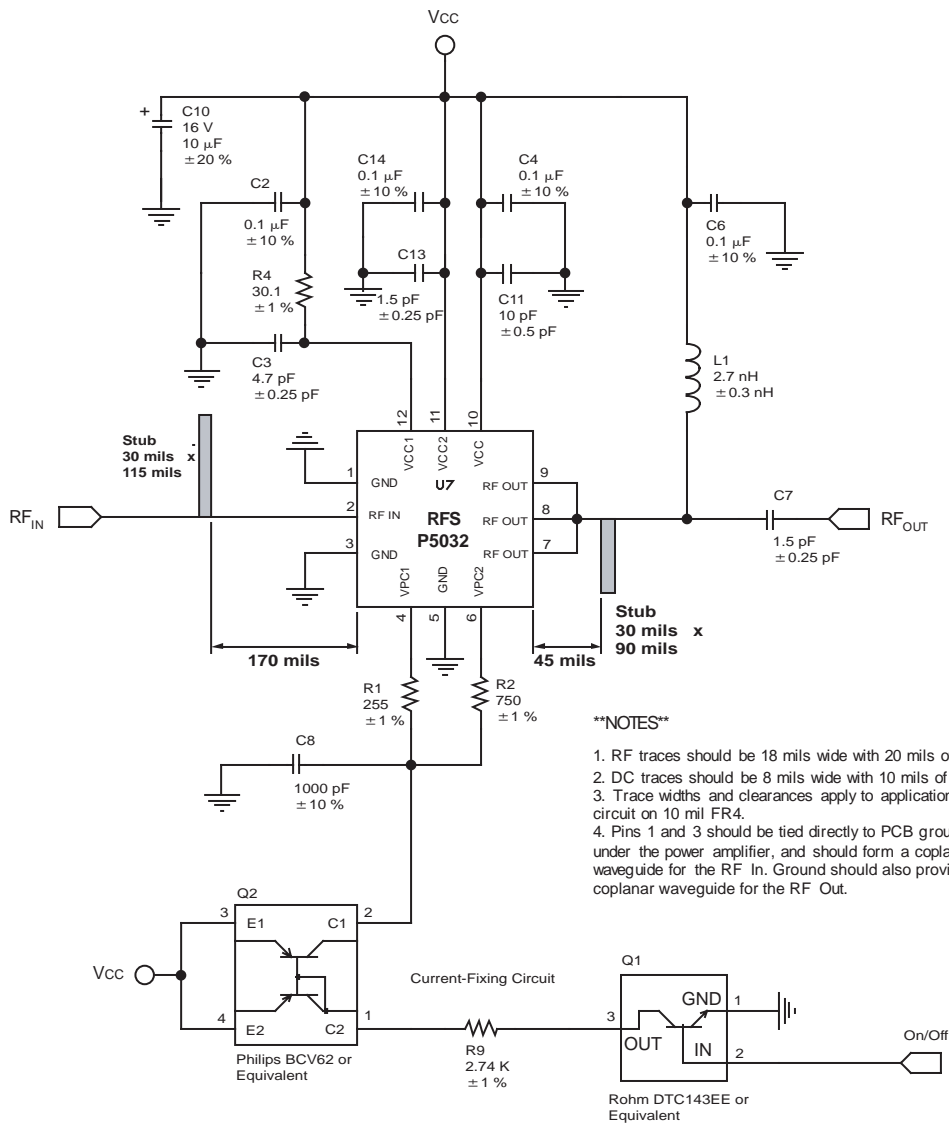
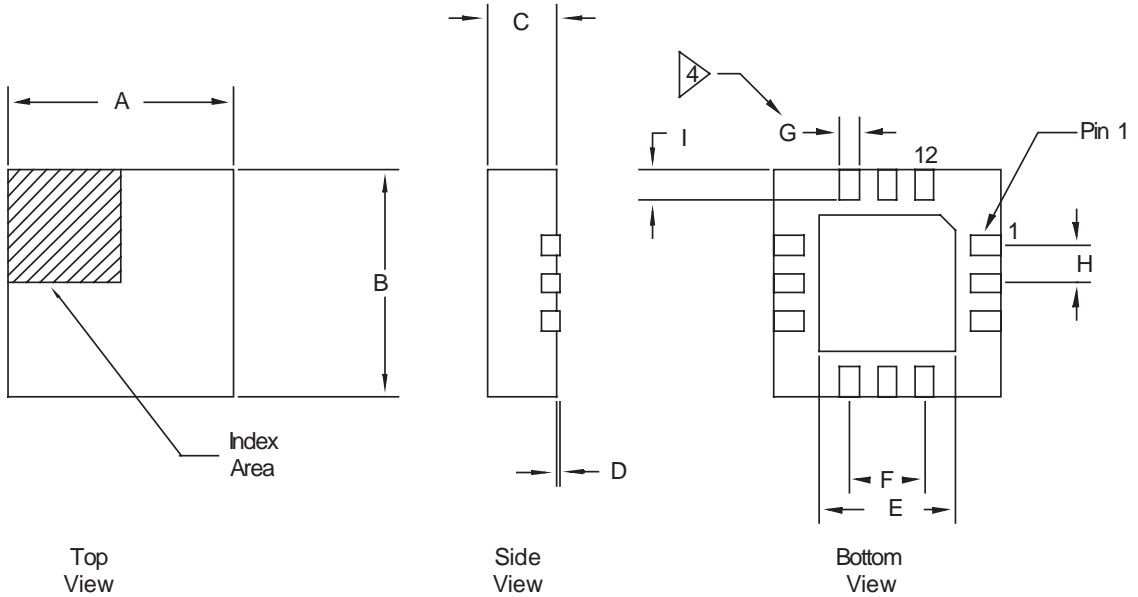

Figure 7: Application Circuit

PACKAGE OUTLINE



DIMENSION	MILLIMETERS		
	MIN	TYP	MAX
A	2.90	3.00	3.10
B	2.90	3.00	3.10
C	0.80	0.90	1.00
D	0.00	0.02	0.05
E	1.50	1.65	1.80
F	1.00 BSC.		
G	0.180	0.250	0.300
H	0.50 BSC.		
I	0.35	0.40	0.45

1. All dimensions are in millimeters, angles in degrees.
2. The terminal #1 identifier and pad numbering convention shall conform to JESD 95-1 SPP-012
3. Lead coplanarity: 0.05 max.
4. Dimension applies to metalized pad and is measured between 0.25 and 0.30 MM from pad tip.

Figure 8: S32 Package Outline - 12 Pin 3 x 3 x 0.9 mm LPCC

TOP BRAND

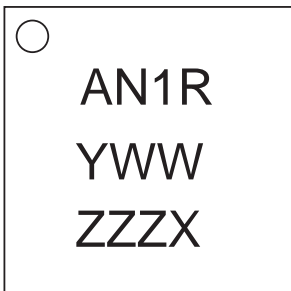

NOTES:

1. Pin 1 INDICATOR: LASER MARK
2. ANADIGICS LOGO SIZE: N/A
3. TEXT: TYPE: ELITE
SIZE: 1.5 Point
4. PART NUMBER: AN = PART NUMBER
1 = CURRENT ISSUE NUMBER OF BOM
R = RoHS COMPLIANCE
5. YEAR AND WORK WEEK: YWW = LAST DIGIT OF YEAR, TWO DIGIT WORK WEEK
6. WAFER LOT NUMBER: ZZZ = LAST THREE DIGITS OF LOT NUMBER
7. COUNTRY CODE: X = C for CHINA, H for HONG KONG,
T for THAILAND, W for TAIWAN,
P for PHILIPPINES, I for INDONESIA

Figure 9: Branding Specification

NOTES

ORDERING INFORMATION

ORDER NUMBER	TEMPERATURE RANGE	PACKAGE DESCRIPTION	COMPONENT PACKAGING
RFS5032RS32Q1	-40 °C to +85°C	12 Pin 3 mm x 3 mm x 0.9 mm LPCC	1,000 piece Tape and Reel
RFS5032RS32P0	-40 °C to +85°C	12 Pin 3 mm x 3 mm x 0.9 mm LPCC	1-999 piece Tubes
RFS5032RS32P6	-40 °C to +85°C	12 Pin 3 mm x 3 mm x 0.9 mm LPCC	1-999 piece Tray
EVA5032RS32	-40 °C to +85°C	12 Pin 3 mm x 3 mm x 0.9 mm LPCC	1 piece Evaluation Board

**ANADIGICS, Inc.**

141 Mount Bethel Road
Warren, New Jersey 07059, U.S.A.

Tel: +1 (908) 668-5000

Fax: +1 (908) 668-5132

URL: <http://www.anadigics.com>

E-mail: Mktg@anadigics.com

IMPORTANT NOTICE

ANADIGICS, Inc. reserves the right to make changes to its products or to discontinue any product at any time without notice. The product specifications contained in Advanced Product Information sheets and Preliminary Data Sheets are subject to change prior to a product's formal introduction. Information in Data Sheets have been carefully checked and are assumed to be reliable; however, ANADIGICS assumes no responsibilities for inaccuracies. ANADIGICS strongly urges customers to verify that the information they are using is current before placing orders.

WARNING

ANADIGICS products are not intended for use in life support appliances, devices or systems. Use of an ANADIGICS product in any such application without written consent is prohibited.