

12 Melody Music Generator

Features

- Operating voltage: 2.4V~5.0V
- Operating frequency: 8MHz
- Two operating mode MCU control mode key control mode
- Low voltage detect
- Volume control
- Hold key
- Rang detect
- Hook
- Mono output
- High D/A converter resolution: 16 bits
- Polyphonic up to 8 notes
- 16-pin DIP, 20-pin SOP package

General Description

The HT38A5 is a CMOS VLSI designed for musical instruments, especially 12 melody songs. The HT38A5 is built-in with a controller and an WTS (Wave Table Synthesizer).

The HT38A5 has applications in areas such as phone ringtones, high function toys, musical boxes, doorbells etc.

Block Diagram

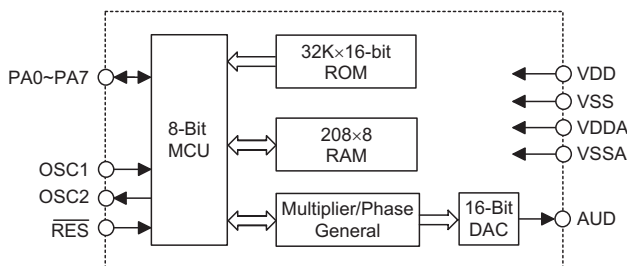

Pin Assignment

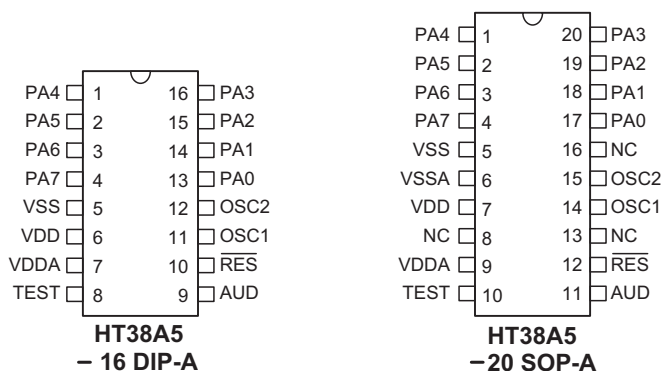

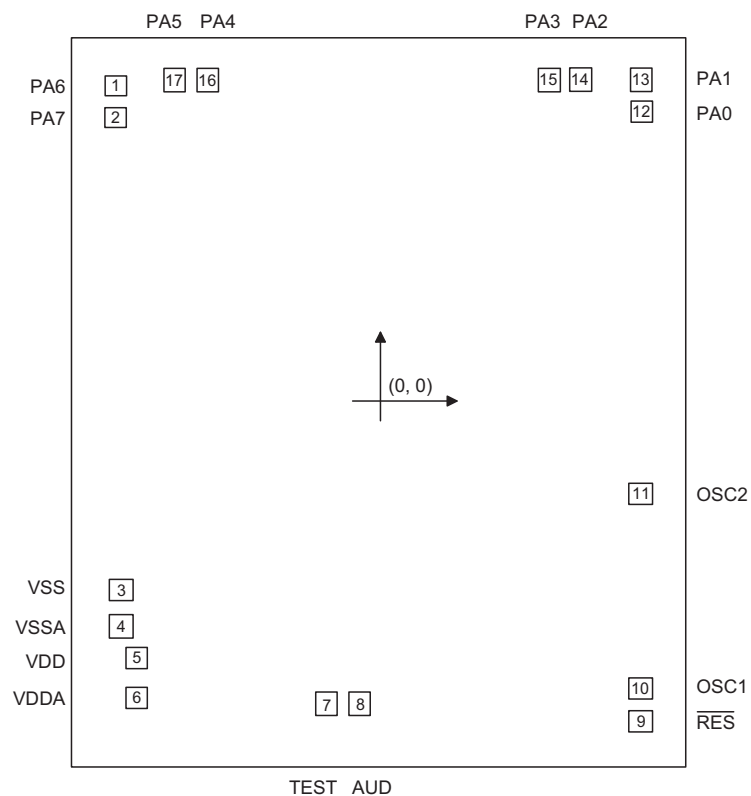
Pad Assignment

Chip size: 2110 × 2530 (μm)²

* The IC substrate should be connected to VSS in the PCB layout artwork.

Pad Coordinates

Unit: μm

Pad No.	X	Y	Pad No.	X	Y
1	-903.425	1096.250	10	900.650	-994.626
2	-903.425	985.650	11	900.650	-316.774
3	-882.900	-650.050	12	901.625	1006.000
4	-882.900	-776.910	13	901.625	1116.600
5	-831.950	-886.910	14	697.050	1114.025
6	-831.950	-1025.350	15	586.450	1114.025
7	-177.390	-1045.600	16	-588.250	1114.025
8	-65.590	-1045.600	17	-698.850	1114.025
9	900.650	-1107.950			

Pad Description

Pad Name	I/O	Internal Connection	Function
PA0~PA7	I/O	Pull-High or None	Mode select and control pia.
VSSA	—	—	Negative power supply of DAC, ground
VSS	—	—	Negative power supply, ground
VDD	—	—	Positive power supply
VDDA	—	—	DAC power supply
TEST	—	—	No connection (open)
AUD	O	—	Audio output for driving a external transistor or for driving HT82V733
RES	I	—	Reset input, active low
OSC1 OSC2	I O	—	OSC1 and OSC2 are connected to an RC network or a crystal (by mask option) for the internal system clock. In the case of RC operation, OSC2 is the output terminal for 1/8 system clock. The system clock may come from the crystal, the two pins cannot be floating.

Absolute Maximum Ratings

Supply Voltage	$V_{SS}-0.3V$ to $V_{SS}+5.5V$	Storage Temperature	$-50^{\circ}C$ to $125^{\circ}C$
Input Voltage	$V_{SS}-0.3V$ to $V_{DD}+0.3V$	Operating Temperature	$-25^{\circ}C$ to $70^{\circ}C$

Note: These are stress ratings only. Stresses exceeding the range specified under "Absolute Maximum Ratings" may cause substantial damage to the device. Functional operation of this device at other conditions beyond those listed in the specification is not implied and prolonged exposure to extreme conditions may affect device reliability.

D.C. Characteristics
 $T_a=25^{\circ}C$

Symbol	Parameter	Test Conditions		Min.	Typ.	Max.	Unit
		V_{DD}	Conditions				
V_{DD}	Operating Voltage	—	—	2.4	3	5	V
I_{DD}	Operating Current	5V	No load $f_{OSC}=8MHz$	—	8	16	mA
I_{STB}	Standby Current (WDT Disabled)	5V	No load System HALT	—	1	—	μA
I_{OL}	I/O Ports Sink Current	5V	$V_{OL}=0.5V$	9.7	16.2	—	mA
I_{OH}	I/O Ports Source Current	5V	$V_{OH}=4.5V$	-5.2	-8.7	—	mA
R_{PH}	Pull-High Resistance of I/O Ports	5V	$V_{IL}=0V$	11	22	44	$k\Omega$
V_{IH1}	Input High Voltage for I/O Ports	5V	—	3.5	—	5	V
V_{IL1}	Input Low Voltage for I/O Ports	5V	—	0	—	1.5	V
V_{IH2}	Input High Voltage (\overline{RES})	5V	—	—	4	—	V
V_{IL2}	Input Low Voltage (\overline{RES})	5V	—	—	2.5	—	V

A.C. Characteristics

Ta=25°C

Symbol	Parameter	Test Conditions		Min.	Typ.	Max.	Unit
		V _{DD}	Conditions				
MCU interface							
f _{OSC}	System Frequency	5V	8MHz crystal	—	8	—	MHz
f _{SYS}	System Clock	5V	—	4	—	8	MHz
t _{WDT}	Watchdog Time-Out Period (RC)	—	Without WDT prescaler	9	17	35	ms
t _{RES}	External Reset Low Pulse Width	—	—	1	—	—	μs

Function Description

Mode selection	PA0=0, key control mode PA0=1, MCU control mode
Low voltage detect	PA4=0,(normal) ;PA4=1(low voltage active, program stop)

Key Control Mode

PA1: Melody select key	This key chooses and plays one of the 12 stored musical melodies. When the key is pressed the next melody in the list will be selected and played. When the HOLD key is pressed the telephone hold function will be activated and when an incoming ring signal is detected the music will be played.
PA2: Volume key	Controls the music volume in 8 discrete steps. Each time the key is pressed the volume will reduce one step at a time until the lowest volume is reached. When the lowest volume is reached, the next key press will return the volume to its maximum level.
PA3: Telephone Hold key	If this key is pressed during a phone conversation the phone will be put on hold and the caller can listen to the music while waiting. If, when the music is playing, the handset is lifted, the music will immediately stop playing. After this happens the HOLD function will have no effect for a period of 2 seconds.
PA6: Ring Detect	When an incoming 13Hz~90Hz ring signal is detected after a period of 200ms, the music will automatically start playing. When the incoming ring signal stops, after a period of 6 seconds the music will stop playing.
PA7: Hook Detect	This line detects the on/off hook condition of the telephone. Only when the telephone is in an on-hook condition, can the music be chosen and played. If the handset is lifted to talk, the music will stop playing and the HOLD key will be effective.

Communication with External MCU Control Mode (Clock Mode) Communication with External CPU

PA6:clock pin	Clock from external CPU
PA7:data pin	Data from external CPU

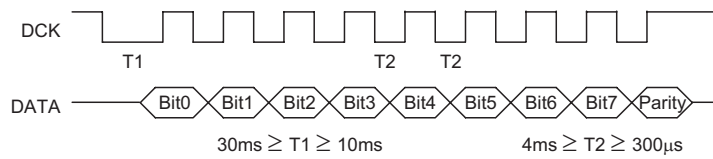
Timing Chart

Note: 400ms after power up, the device will be ready to communicate with the external CPU using the CLK and DATA lines.

Communication via the CLK and DATA lines is conducted in a simple manner. The device will obtain its data on the high going edge of the CLK line. If the device does not receive a complete byte within 50ms then the present byte will be discarded and the next byte will then be received.

Even-parity is used for data checking. For the previous 8-bits, if the total number of "1s" is odd then the parity bit is set to "1", otherwise it is set to "0". If the parity is incorrect then the byte will be discarded.

Data Type (Command)

00h~0bh	This command will select and play one of the 12 stored musical melodies. If the chosen melody number exceeds the highest number of that stored in the device then the command will be ignored and no action taken.
40h-4fh	16 level volume control, 40h refers to highest volume
50h	Stop play

Melody List

Command	English Song Name
00h	Toreador Song
01h	Jingle Bells
02h	Chinese New Year
03h	Santa Lucia
04h	My Old Kentucky Home
05h	La Cucaracha
06h	Allegro
07h	I'm a Little Teapot
08h	Sabre Dance
09h	Happy Birthday to You
0Ah	Working on the Railroad
0Bh	Radetzky March

Application Circuits

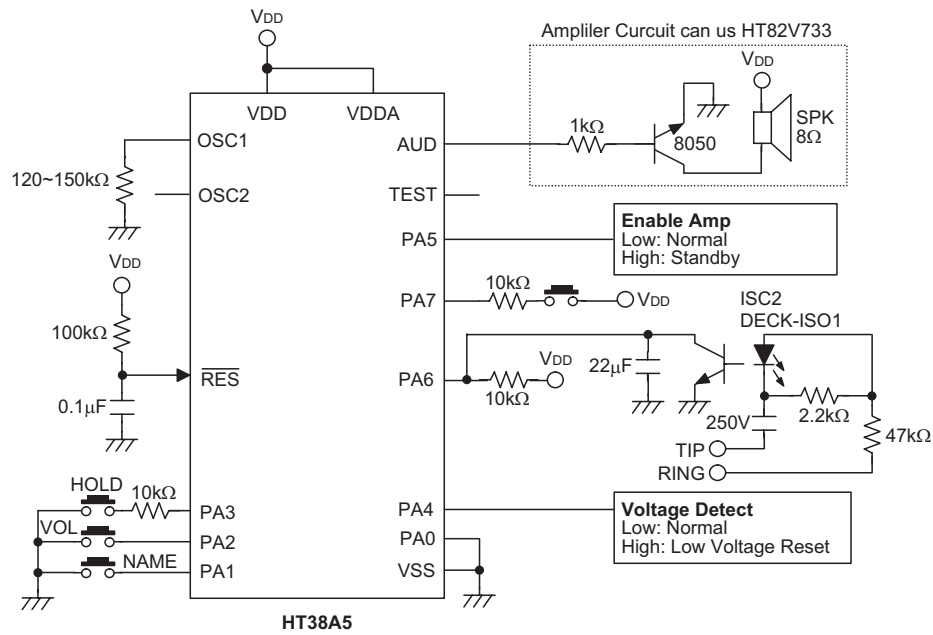
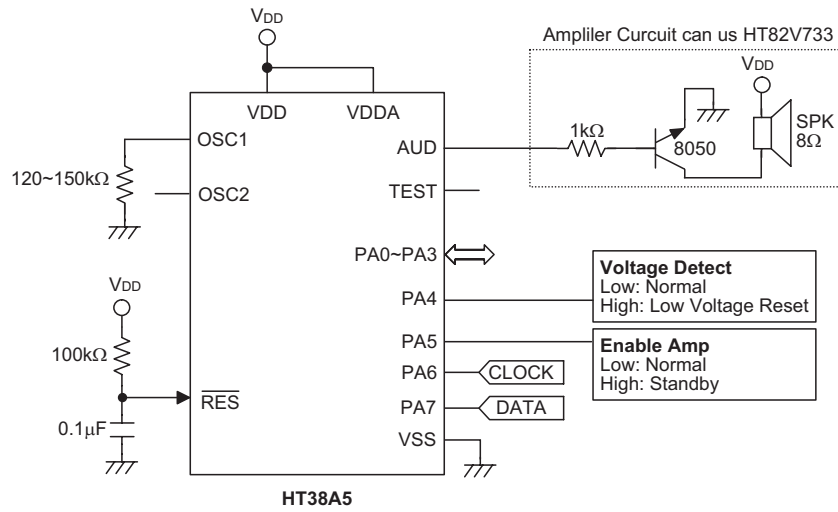

Package Information

16-pin DIP (300mil) Outline Dimensions

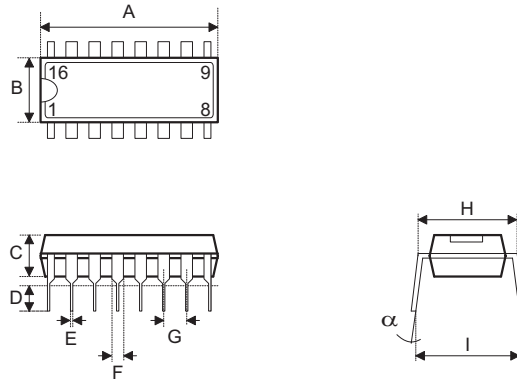

Symbol	Dimensions in mil		
	Min.	Nom.	Max.
A	745	—	775
B	240	—	260
C	125	—	135
D	125	—	145
E	16	—	20
F	50	—	70
G	—	100	—
H	295	—	315
I	335	—	375
α	0°	—	15°

20-pin SOP (300mil) Outline Dimensions

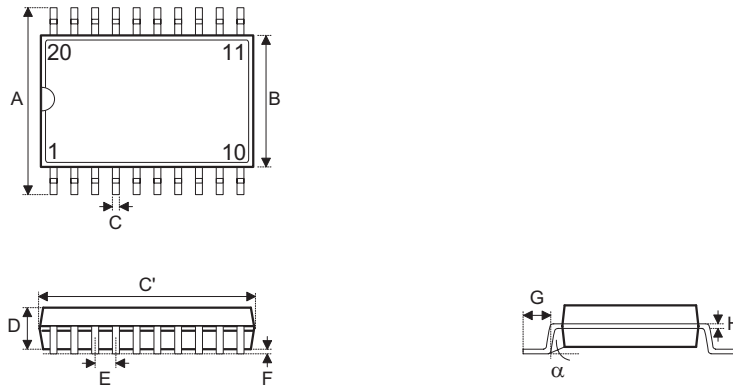

Symbol	Dimensions in mil		
	Min.	Nom.	Max.
A	394	—	419
B	290	—	300
C	14	—	20
C'	490	—	510
D	92	—	104
E	—	50	—
F	4	—	—
G	32	—	38
H	4	—	12
α	0°	—	10°

Product Tape and Reel Specifications

Reel Dimensions

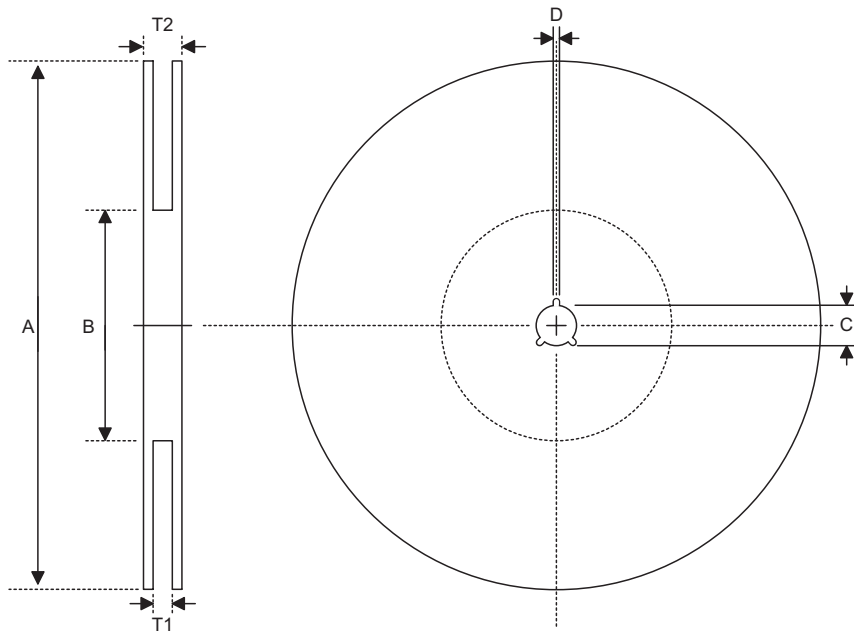

SOP 20W

Symbol	Description	Dimensions in mm
A	Reel Outer Diameter	330±1.0
B	Reel Inner Diameter	62±1.5
C	Spindle Hole Diameter	13.0+0.5 -0.2
D	Key Slit Width	2.0±0.5
T1	Space Between Flange	24.8+0.3 -0.2
T2	Reel Thickness	30.2±0.2

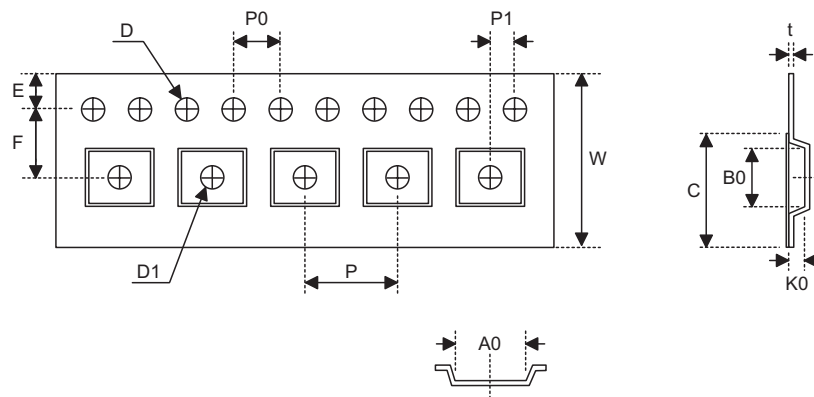
Carrier Tape Dimensions

SOP 20W

Symbol	Description	Dimensions in mm
W	Carrier Tape Width	24.0+0.3 -0.1
P	Cavity Pitch	12.0±0.1
E	Perforation Position	1.75±0.1
F	Cavity to Perforation (Width Direction)	11.5±0.1
D	Perforation Diameter	1.5+0.1
D1	Cavity Hole Diameter	1.5+0.25
P0	Perforation Pitch	4.0±0.1
P1	Cavity to Perforation (Length Direction)	2.0±0.1
A0	Cavity Length	10.8±0.1
B0	Cavity Width	13.3±0.1
K0	Cavity Depth	3.2±0.1
t	Carrier Tape Thickness	0.3±0.05
C	Cover Tape Width	21.3

Holtek Semiconductor Inc. (Headquarters)

No.3, Creation Rd. II, Science Park, Hsinchu, Taiwan
Tel: 886-3-563-1999
Fax: 886-3-563-1189
<http://www.holtek.com.tw>

Holtek Semiconductor Inc. (Taipei Sales Office)

4F-2, No. 3-2, YuanQu St., Nankang Software Park, Taipei 115, Taiwan
Tel: 886-2-2655-7070
Fax: 886-2-2655-7373
Fax: 886-2-2655-7383 (International sales hotline)

Holtek Semiconductor Inc. (Shanghai Sales Office)

7th Floor, Building 2, No.889, Yi Shan Rd., Shanghai, China 200233
Tel: 021-6485-5560
Fax: 021-6485-0313
<http://www.holtek.com.cn>

Holtek Semiconductor Inc. (Shenzhen Sales Office)

5/F, Unit A, Productivity Building, Cross of Science M 3rd Road and Gaoxin M 2nd Road, Science Park, Nanshan District, Shenzhen, China 518057
Tel: 0755-8616-9908, 8616-9308
Fax: 0755-8616-9533

Holtek Semiconductor Inc. (Beijing Sales Office)

Suite 1721, Jinyu Tower, A129 West Xuan Wu Men Street, Xicheng District, Beijing, China 100031
Tel: 010-6641-0030, 6641-7751, 6641-7752
Fax: 010-6641-0125

Holtek Semiconductor Inc. (Chengdu Sales Office)

709, Building 3, Champagne Plaza, No.97 Dongda Street, Chengdu, Sichuan, China 610016
Tel: 028-6653-6590
Fax: 028-6653-6591

Holmate Semiconductor, Inc. (North America Sales Office)

46729 Fremont Blvd., Fremont, CA 94538
Tel: 510-252-9880
Fax: 510-252-9885
<http://www.holmate.com>

Copyright © 2006 by HOLTEK SEMICONDUCTOR INC.

The information appearing in this Data Sheet is believed to be accurate at the time of publication. However, Holtek assumes no responsibility arising from the use of the specifications described. The applications mentioned herein are used solely for the purpose of illustration and Holtek makes no warranty or representation that such applications will be suitable without further modification, nor recommends the use of its products for application that may present a risk to human life due to malfunction or otherwise. Holtek's products are not authorized for use as critical components in life support devices or systems. Holtek reserves the right to alter its products without prior notification. For the most up-to-date information, please visit our web site at <http://www.holtek.com.tw>.