

7361Z0001SxxLF

Lead Free Version (Optional)
Customer Specificity

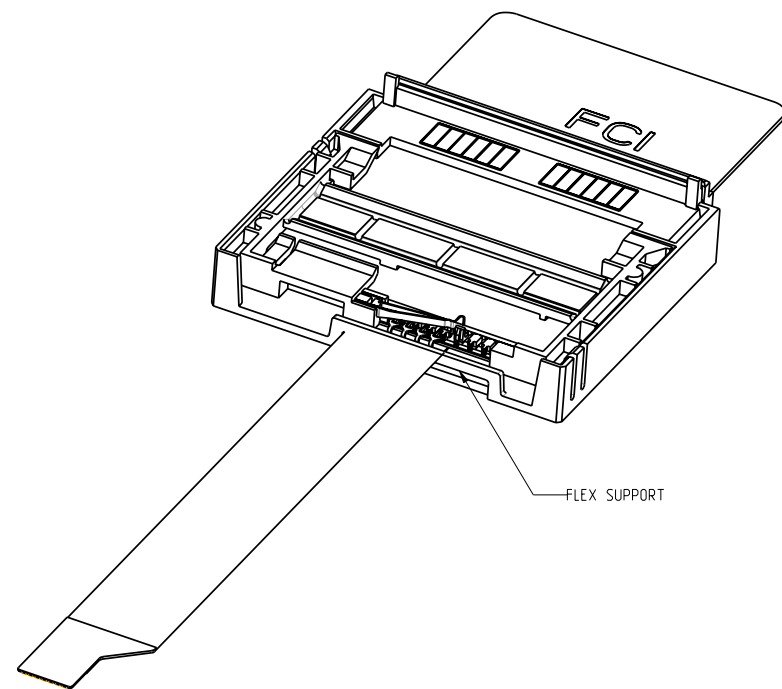
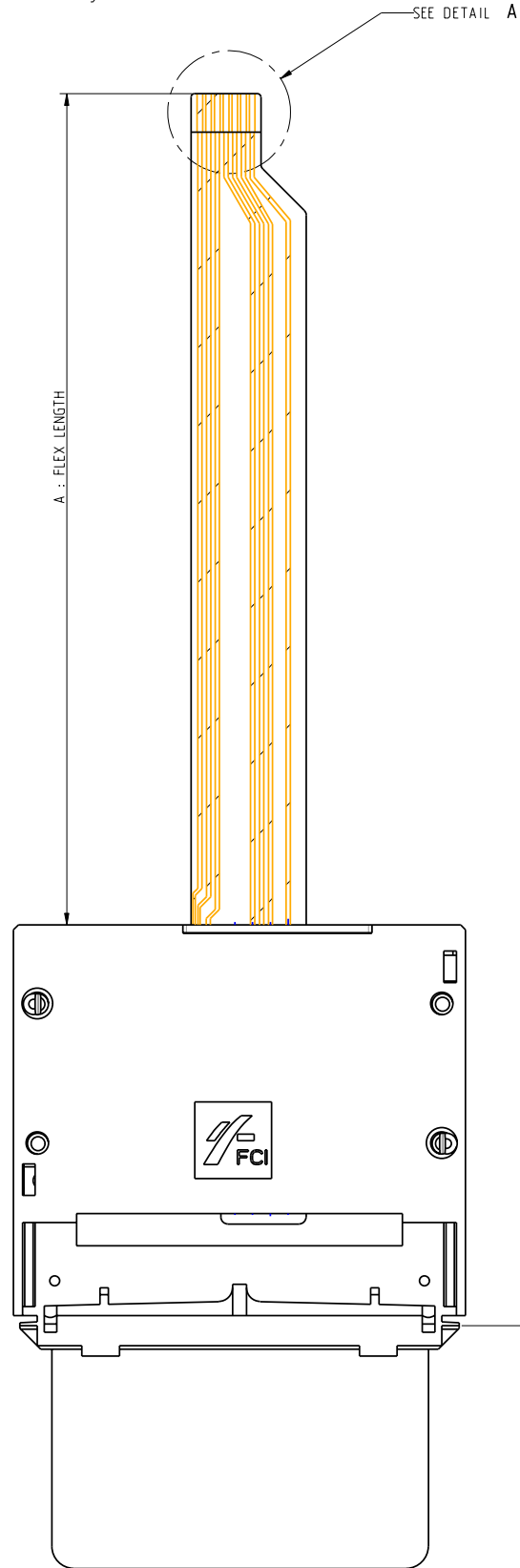
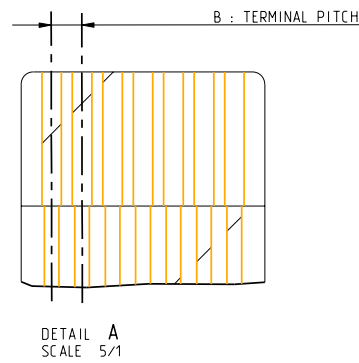

SCALE 19/15

SCALE 3/2

GENERAL

This Smart Card Reader uses a sliding contact technology. It has been designed for easy mounting on metal panel.

ELECTRICAL PROPERTIES

Insulation resistance : 5000 M
Dielectric withstanding : 750 VAC
Current carrying capacity : 10 μ A min. 1A max.
Contact resistance : 100 m
Card sensor type : Blade switch normally closed

MECHANICAL PROPERTIES

EMV compatible and according to ISO 7816-2
Contact normal force : between 0.2 N to 0.6 N per contact
Insertion force : 10 N max.
Withdrawal force : 1 N min.
Max. number of mating operations : 10000 card insertions.

CAPACITOR :

100nF, chip size 0805 in (2012 mm), Y5V, 25V or 50V

READER MATERIAL

Housing : Thermoplastique, 30% GF, Colour black, Rated UL94V0
Contacts and switch : Phosphor bronze
Plating : precoat Nickel 2.5 μ m min. all over
Gold 0.2 μ m min. on contacts areas
SnPB 3 μ m min. on termination contacts for Leaded version
Matte Sn 3 μ on termination end for Leadfree version

ENVIRONMENT

Operating temperature : -20 $^{\circ}$ C / +70 $^{\circ}$ C
Storage temperature : -40 $^{\circ}$ C / +85 $^{\circ}$ C
Panel thickness : 0.8+-0.1 mm

PACKAGING

Trays
Packaging specification : VGN11646

LEAD FREE VERSION:

"This product meets European Union Directives and other country regulations as described in GS-22-008"

The housing will withstand exposure to 260 $^{\circ}$ C peak temperature for 10seconds in a wave solder application with a 1.6mm minimum thick circuit board. Use protective adhesive tape (Kapton orTeflon) or protective metallic devices on the areas which are directly exposed to wave soldering as it is used in classical leaded wave soldering

www.fciconnect.com		tolerance Lin ± 0.1 Ang $\pm 0.5^{\circ}$	projection MM
Dr DILIPTHOMAS '05/08/20	Product family	size A2	Scale 1/2
Eng DILIPTHOMAS '05/08/20	Spec ref	ECN	105-0158
Chr N.TWENCY '05/09/11	Material	SEE NOTES	
Appr N.TWENCY '05/09/11			
title READER PANEL MOUNT		dwg no VJW55019	Rev. B
catalog no SEE TABLE		CUSTOMER COPY sheet 1 of 3	

Tous droits strictement reserves. Reproduction ou communication a des tiers interdite sans autorisation écrite de l'interlocuteur. Propriété de FCI. Droits de reproduction FCI.

FCI

All rights strictly reserved. Reproduction or issue to third parties in any form without written permission is prohibited. Copyright FCI. Property of FCI.

Tous droits strictement réservés. Reproduction ou utilisation sans autorisation écrite de propriétaire.

FCI

All rights strictly reserved. Reproduction or use in third parties in any form without written authority from the proprietor.

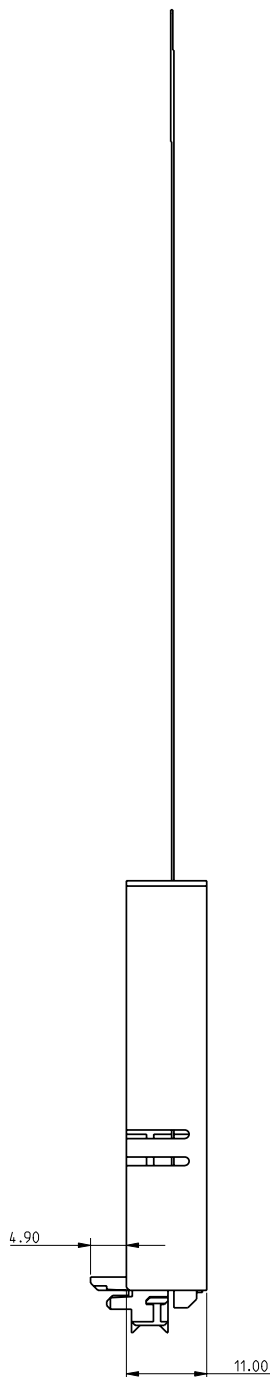
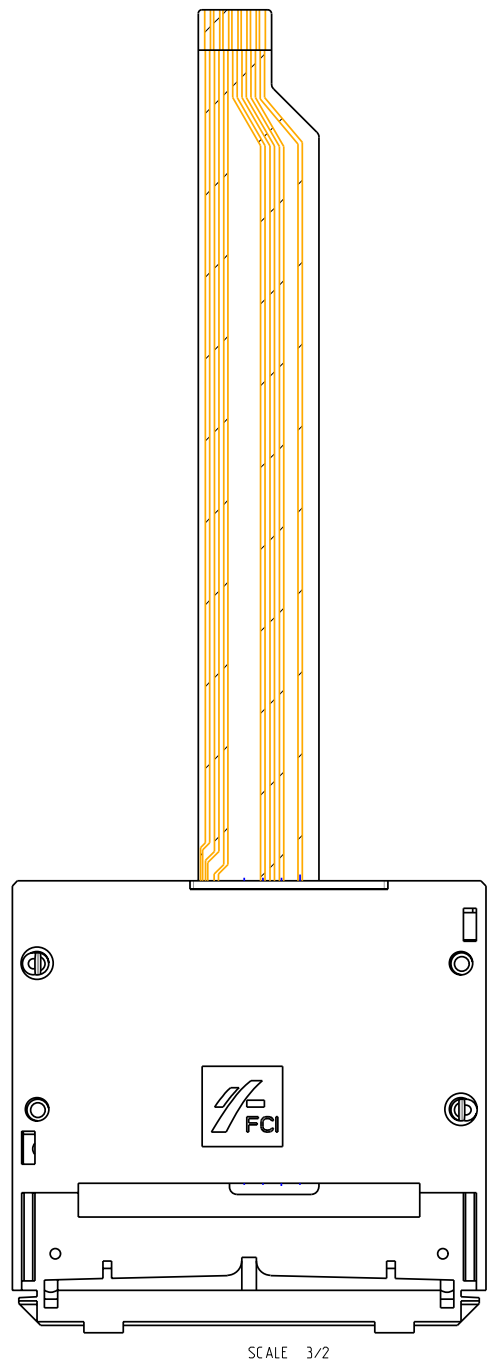
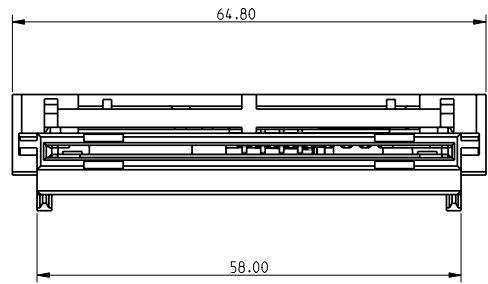

RECOMMENDED FRONT PANEL CUT-OUT

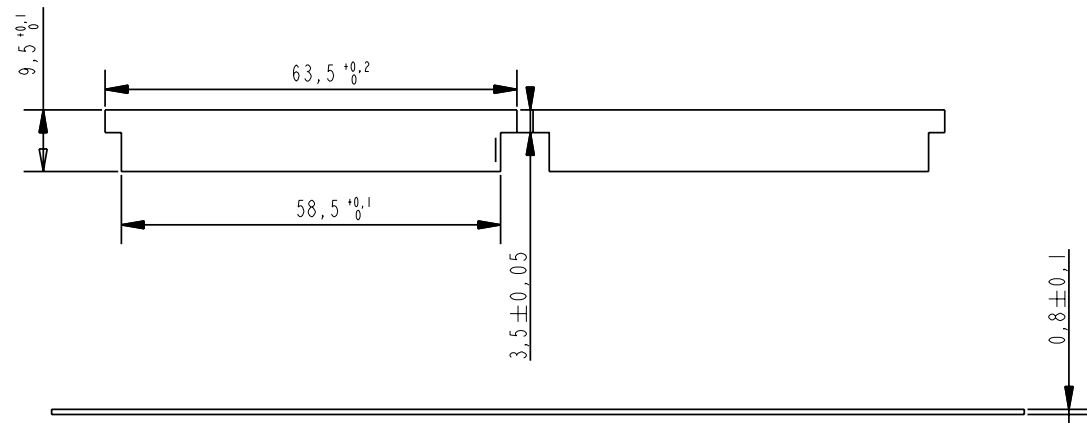

VERTICAL STACKING

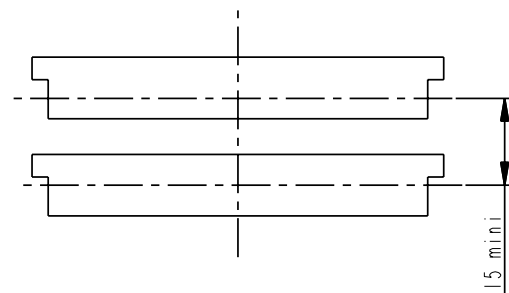

HORIZONTAL STACKING

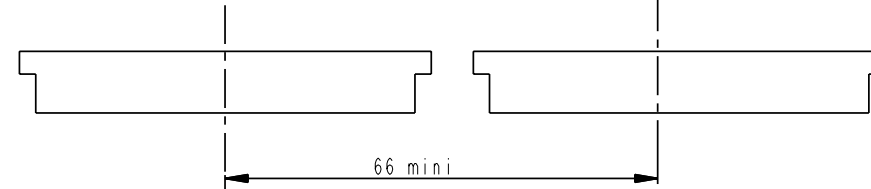

FCI www.fciconnect.com		✓	tolerance Lin ±0.1 Ang ±0.5°	projection MM
Dr	DILIPTHOMAS '05/08/20	Product family	size	Scale
Eng	DILIPTHOMAS '05/08/20	Spec ref	A2	1/2
Chr	N.TWENCY '05/09/11	Material	ECN	105-0158
Appr	N.TWENCY '05/09/11	SEE NOTES		
title READER PANEL MOUNT SMARTCARD		dwg no VJW55019		Rev. B
catalog no		SEE TABLE	CUSTOMER COPY	sheet 2 of 3

7x61Z0001SxxLF

LIST OF PART NUMBERS

X=3, STANDARD TRAY
X=5, ANTISTATIC TRAY



Lead Free Version (Optional)
Customer Specificity

PRODUCT NUMBER	A: FLEX LENGTH (mm)	B: TERMINAL PITCH (mm)	NUMBER OF TRACKS	FLEX FORM	CAPACITOR NUMBER	CONTACT NUMBER	C: DISTANCE PANEL/CARD (mm)	PACKING TYPE
7361Z0001S13	96	1	10	STRAIGHT	2	8 : ISO	35	A
7361Z0001S14	101	1	10	STRAIGHT	2	16 ISO+AFNOR	35	A
7361Z0001S15	96	1	10	STRAIGHT	2	8 : ISO	25	A
7361Z0001S22	156	1.25	10	STRAIGHT	1	16 ISO+AFNOR	35	A
7361Z0001S29	58	1.25	10	STRAIGHT	NONE	8 : ISO	35	A
7561Z0001S29	58	1.25	10	STRAIGHT	NONE	8 : ISO	35	A
7361Z0001S31	58	1.25	10	STRAIGHT	NONE	8 : ISO	25	A
7361Z0001S33	58	1.25	10	STRAIGHT	1	8 : ISO	35	A
7361Z0001S35	120	1.25	10	STRAIGHT	1	8 : ISO	35	A
7361Z0001S36	120	1.25	10	STRAIGHT	1	8 : ISO	15	B
7361Z0001S37	58	1.25	10	STRAIGHT	NONE	8 : ISO	15	B
7361Z0001S38	85	1.25	10	STRAIGHT	1	16 ISO+AFNOR	35	A
7361Z0001S39	58	1.25	10	STRAIGHT	NONE	8 : ISO	35	A
7361Z0001S40	118	1.25	7	STRAIGHT	1	8 : ISO	35	C
7361Z0001S41	118	1.25	7	STRAIGHT	1	8 : ISO	15	B
7361Z0001S42	60	1.25	7	STRAIGHT	NONE	8 : ISO	25	A
7361Z0001S43	58	1.25	10	STRAIGHT	1	8 : ISO	25	A

PACKING TYPE:
 A : 28 CONNECTORS / TRAY
 420 CONNECTORS / SHIPPING BOX
 B : 25 CONNECTORS / BLOCK
 500 CONNECTORS / SHIPPING BOX
 C : 12 CONNECTORS / TRAY
 120 CONNECTORS / SHIPPING BOX

Tous droits strictement réservés. Reproduction ou communication sans autorisation écrite de FCI. Propriété de FCI.

All rights strictly reserved. Reproduction or issue in third parties in any form without written authority from the proprietor. Property of FCI. Copyright ©.

 www.fciconnect.com		<input checked="" type="checkbox"/>	tolerance Lin ±0.1 Ang ±0.5°	projection 	MM 
Dr	DILIPTHOMAS	'05/08/20	Product family	size	Scale
Eng	DILIPTHOMAS	'05/08/20	Spec ref	A2	1/1
Chr	N.TWENCY	'05/09/11	Material	SEE NOTES	ECN 105-0158
Appr	N.TWENCY	'05/09/11			
title READER PANEL MOUNT SMARTCARD			dwg no VJW55019		Rev. B
catalog no SEE TABLE			CUSTOMER COPY		sheet 3 of 3