

Features

- On chip Hall sensor
- Rotor-locked shutdown
- Automatically restart
- Built-in Zener protection for output driver
- Operating voltage: 3.8V~28V
- Output current: $I_{O(AVE)} = 400\text{mA}$
- Lead Free Finish/RoHS Compliant for Lead Free products (Note 1)
- Lead Free Packages: SIP-4L and SOT89-5L

General Description

AH287 is a monolithic fan motor controller with Hall sensor's capability. It contains two complementary open-drain drivers for motor's coil driving, automatic lock shutdown and restart function relatively.

Rotor-lock shutdown detection circuit turns off the output driver when the rotor is blocked to avoid coil overheat. Then, the automatic recovery circuit will restart the motor. These protected actions are repeated and periodic during the blocked period. Until the blocking is removed, the motor recovers and runs normally.

Ordering Information

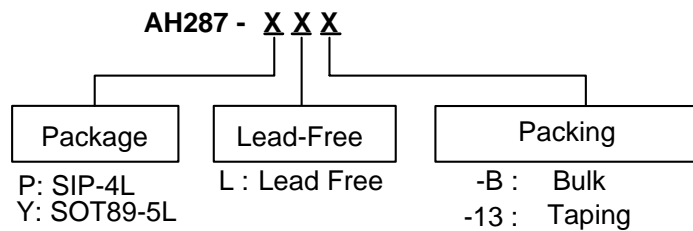

Note: 1. RoHS revision 13.2.2003. Glass and High Temperature Solder Exemptions Applied, see *EU Directive Annex Notes 5 and 7*.

Device	Package Code	Packaging (Note 2)	Tube/Bulk		7" Tape and Reel	
			Quantity	Part Number Suffix	Quantity	Part Number Suffix
AH287-P	P	SIP-4L	1000	-B	NA	NA
AH287-Y	Y	SOT89-5L	NA	NA	2500/Tape & Reel	-13

Note: 2. Pad layout as shown on Diodes Inc. suggested pad layout document AP02001, which can be found on our website at <http://www.diodes.com/datasheets/ap02001.pdf>.

Pin Assignment

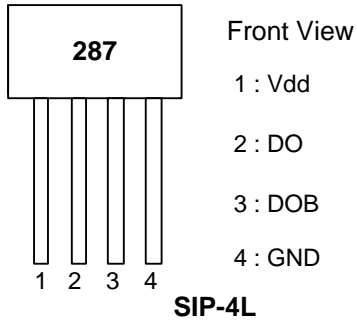

Pin Descriptions

Name	Description
Vdd	Input power
DO	Output pin
DOB	Output pin
GND	Ground
NC	Not connected

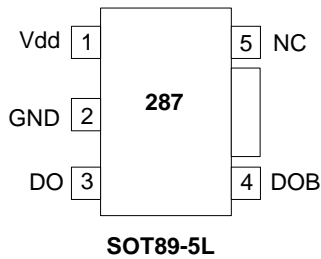

Block Diagram (SIP-4L)

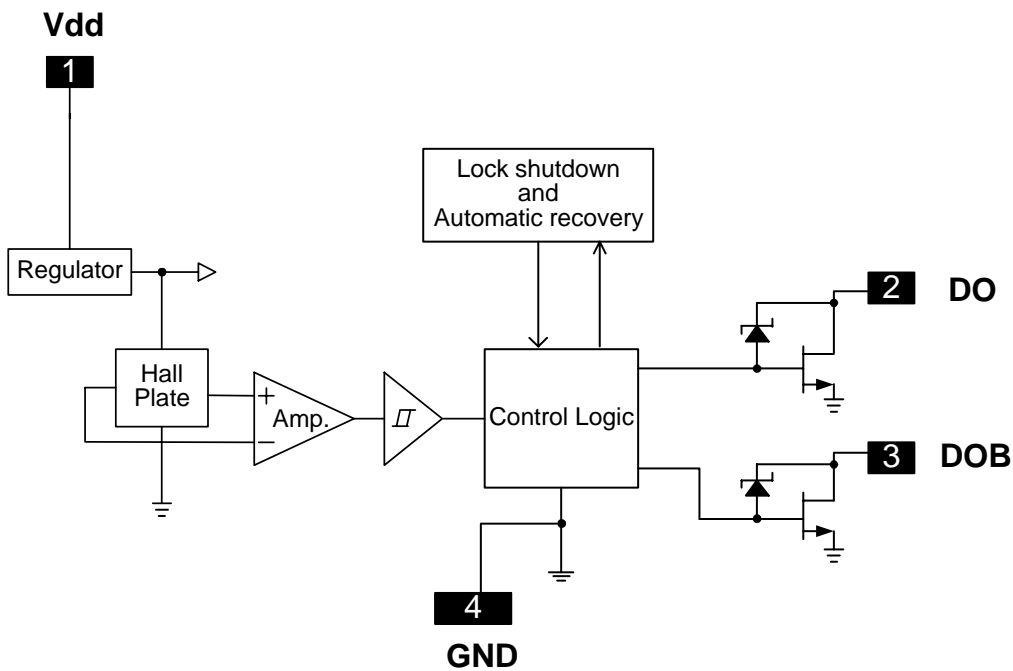

Typical Application Circuit (SIP-4L)

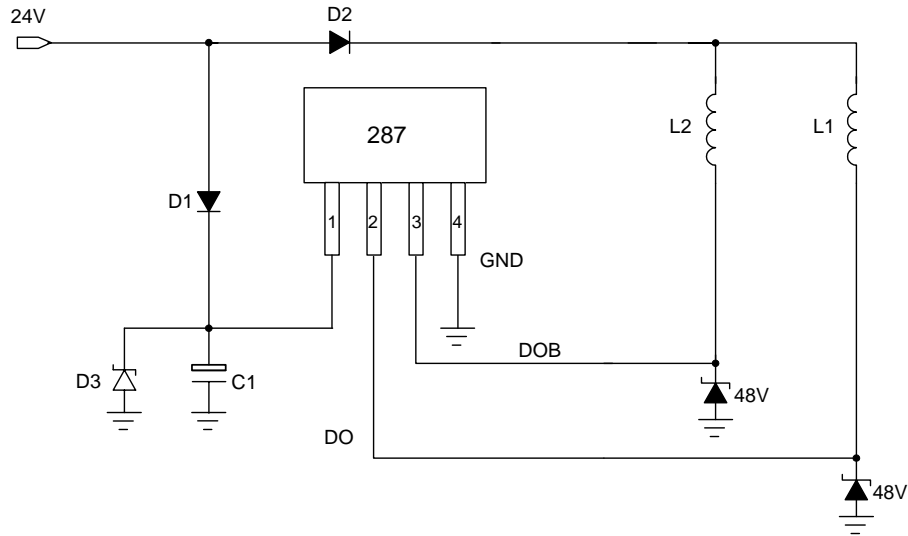

24V brush-less DC fan

Note: 3. The optional Capacitor C1 and Diode D3 are for power stabilization. C1 is recommended to be E-Cap., $\mu\text{F}/25\text{V}$; D3 is recommended to be Zener Diode, $V_Z=27\text{V}$. Which C1 and D3 value need to be fine tuned to optimize design for different coils and power suppliers.

Absolute Maximum Ratings ($T_A = 25^\circ\text{C}$)

Characteristics	Symbol	Rating	Unit	
Supply Voltage	Vdd	30	V	
Output Current	$I_{O(AVE)}$	SIP-4L/SOT89-5L	mA	
	$I_{O(PEAK)}$			700
Power Dissipation	P_D	SIP-4L	550	mW
		SOT89-5L	800	
Operating Temperature	T_{opr}	-40 ~ 100	$^\circ\text{C}$	
Storage Temperature	T_{stg}	-55 ~ 150	$^\circ\text{C}$	
Maximum Junction Temp.	T_j	150	$^\circ\text{C}$	
Thermal Resistance	θ_{JA}	SIP-4L	227	$^\circ\text{C}/\text{W}$
		SOT89-5L	156	$^\circ\text{C}/\text{W}$

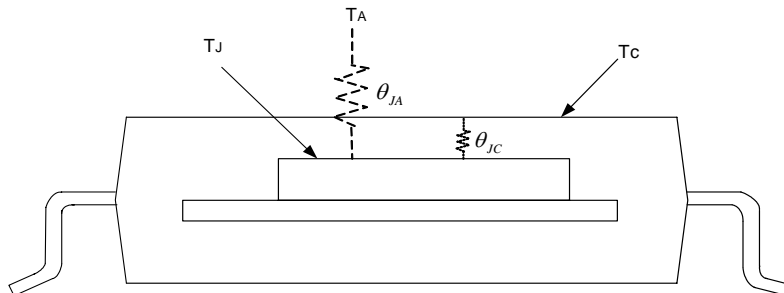

Note: 4. θ_{JA} should be confirmed with what heat sink thermal resistance. If no heat sink contacting, θ_{JA} is almost the same as θ_{JC} .

Electrical Characteristics (T_A = 25 °C, V_{dd} = 24V, unless otherwise specified)

Characteristics	Symbol	Conditions	Min.	Typ.	Max.	Unit
Supply Voltage	V _{dd}	Operating	3.8	-	28*	V
Supply current	I _{cc}	Operating	-	2.0	4.0	mA
Output Leakage Current	I _{off}	V _{OUT} =24V	-	< 0.1	10	μA
Locked Protection On	Tl _{rp-on}		0.4	0.46	0.6	Sec
Locked Protection Off	Tl _{rp-off}		2.4	2.76	3.6	Sec
Output saturation voltage	V _{OUT(sat)}	I _O =200mA	-	450	700	mV
		I _O =300mA	-	680	800	
Output On resistance	R _{ds(on)}	I _O =200mA	-	2.25	3.5	ohm
Output Zener-breakdown Voltage	V _Z		42	55	65	V

*Note: Please watch out the current limit issue when the operation voltage is over 26.4V, because of the different efficiency in the coil.

Truth Table

IN-	IN+	CT	OUT1	OUT2	Mode
H	L	L	H	L	Rotating
L	H	L	L	H	Rotating
-	-	H	off	off	Lockup protection activated

Magnetic Characteristics (T_A = 25 °C, V_{dd} = 24V, unless otherwise specified)

(1mT=10 Gauss)

Characteristics	Symbol	Min.	Typ.	Max.	Unit
Operate Point	B _{op}	10	30	60	Gauss
Release Point	B _{rp}	-60	-30	-10	Gauss
Hysteresis	B _{hy}	--	60	--	Gauss

Operating Characteristics

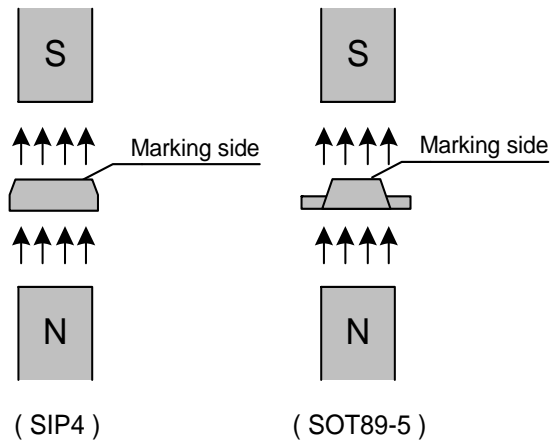
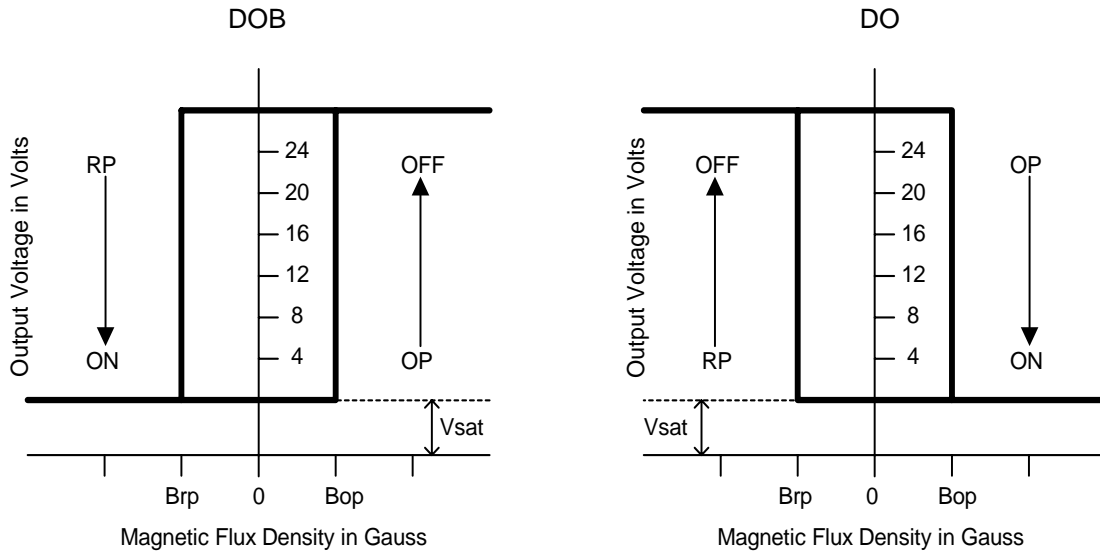

Performance Characteristics (SIP-4L)

T_A (°C)	25	50	60	70	80	85	90	95	100
P _D (mW)	550	440	396	352	308	286	264	242	220
T_A (°C)	105	110	115	120	125	130	135	140	150
P _D (mW)	198	176	154	132	110	88	66	44	0

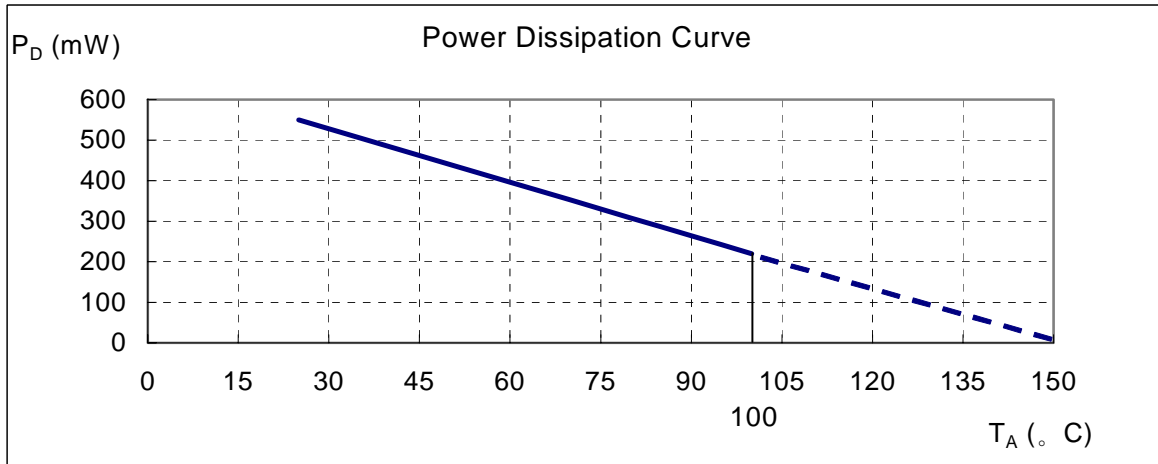

Performance Characteristics (SOT89-5L)

T_A (°C)	25	50	60	70	75	80	85	90	95	100
P _D (mW)	800	640	576	512	480	448	416	384	352	320
T_A (°C)	105	110	115	120	125	130	135	140	145	150
P _D (mW)	288	256	224	192	160	128	96	64	32	0

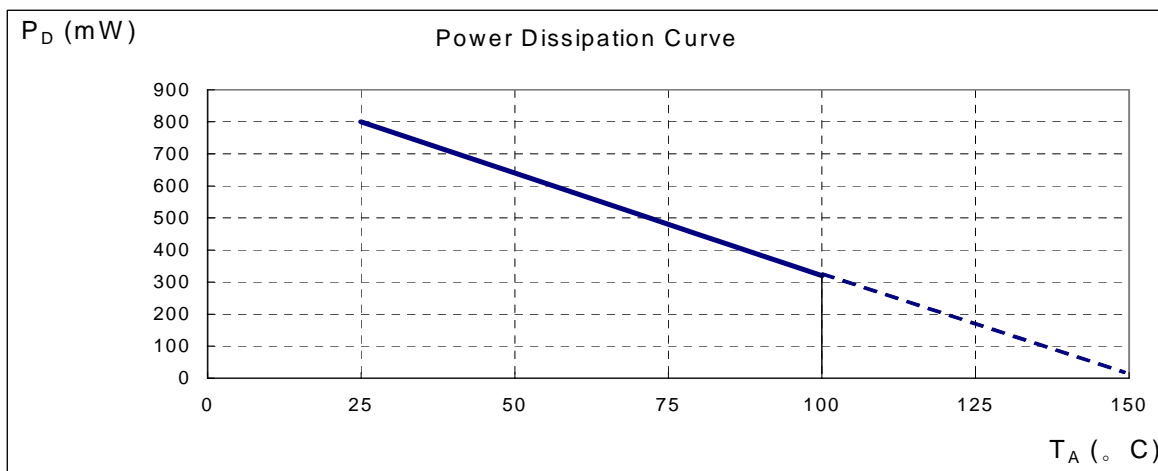

Marking Information

(1) SIP-4L

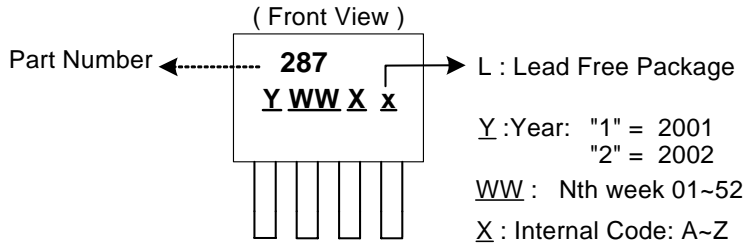

(2) SOT89-5L

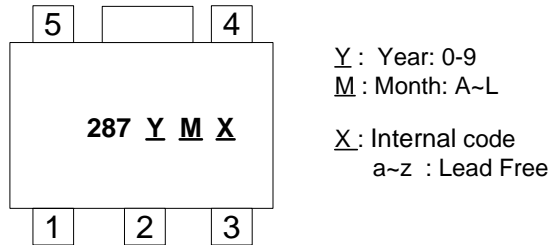

Package Information (unit: mm)

(1) SIP-4L

Active Area Depth

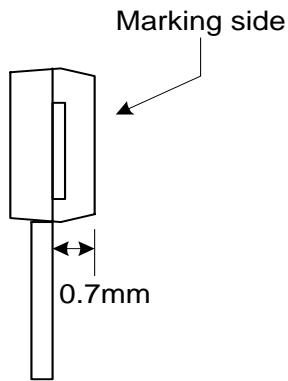

Package Sensor Location

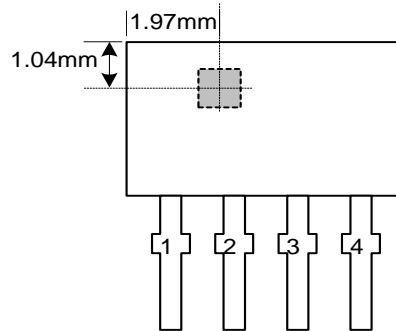

Package Dimension

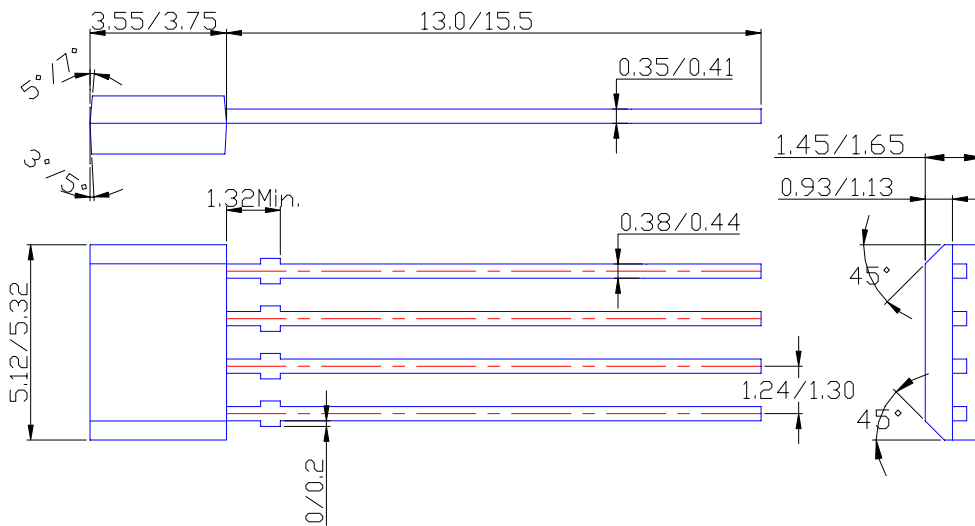

Package Information (Continued)

(2) SOT89-5L

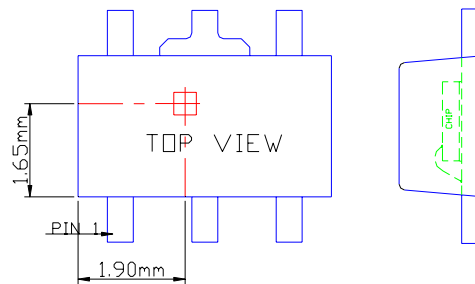
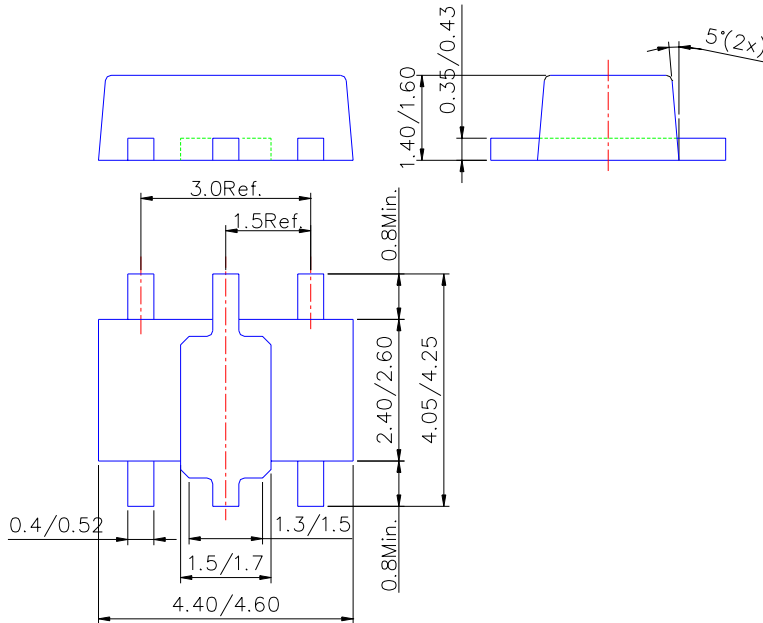

Sensor Location

IMPORTANT NOTICE

Diodes Incorporated and its subsidiaries reserve the right to make modifications, enhancements, improvements, corrections or other changes without further notice to any product herein. Diodes Incorporated does not assume any liability arising out of the application or use of any product described herein; neither does it convey any license under its patent rights, nor the rights of others. The user of products in such applications shall assume all risks of such use and will agree to hold Diodes Incorporated and all the companies whose products are represented on our website, harmless against all damages.

LIFE SUPPORT

Diodes Incorporated products are not authorized for use as critical components in life support devices or systems without the expressed written approval of the President of Diodes Incorporated.