

General Description:

The Durel® D371 is part of a family of highly integrated EL drivers based on Durel's patented three-port (3P) topology, which offers built-in EMI shielding. This high-performance device uses a proprietary circuit design for programmable wave-shaping for low-noise performance in applications that are sensitive to audible and electrical noise.

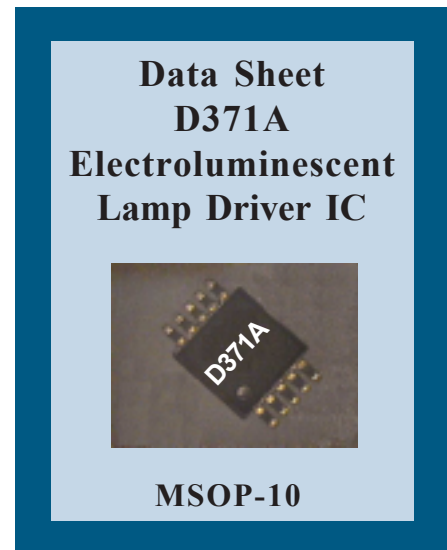

Features

- Flexible Wave Shaping Capability
- High Efficiency
- Small Package Size
- Adjustable Output Frequency
- High Voltage AC Output
- External Clock Compatible

Applications

- Cellular Phones and Handsets
- Data Organizers/PDAs
- LCD and Keypad Backlighting

Lamp Driver Specifications:

(Using Standard Test Circuit at Ta=25 °C unless otherwise specified.)

Parameter	Symbol	Minimum	Typical	Maximum	Unit	Conditions
Standby Current			5	1000	nA	E = GND
Supply Current	I		15	18	mA	E = 3.0V
Enable Current			15		uA	E = 3.0V
Output Voltage	Vout	160	188	220	Vpp	
Lamp Frequency	LF	190	260	330	Hz	CLF=3.9 nF
Inductor Frequency	HF		23		kHz	CHF=68 pF

Standard Test Circuit

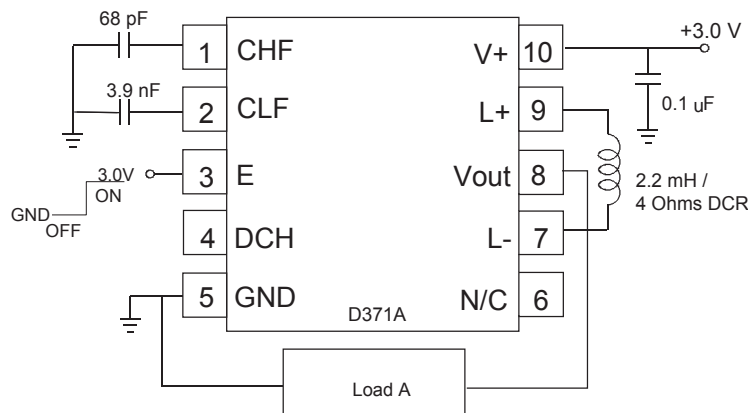

Load A*

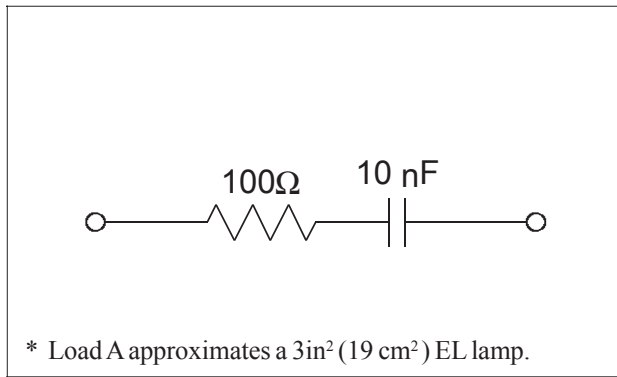

Typical Output Waveform



Absolute Maximum Ratings:

Parameter	Symbol	Minimum	Maximum	Unit	Comments
Supply voltage					
Operating Range	V+	2.0	6.5	V	E = V+
Withstand Range		-0.5	9.0		E = GND
Enable Voltage	E	-0.5	(V+)+0.5	V	
Output Voltage	V _{OUT}		220	V _{pp}	Peak-to-Peak Voltage
CHF Voltage	V _{CHF}	0	(V+)+0.3	V	External clock input
CLF Voltage	V _{CLF}	0	(V+)+0.3	V	External clock input
Operating Temperature	T _a	-40	85	°C	
Storage Temperature	T _s	-65	150	°C	

Note: The above are stress ratings only. Functional operation of the device at these ratings or any other above those indicated in the specifications is not implied. Exposure to absolute maximum rating conditions for extended periods of time may affect reliability.

Physical Data:

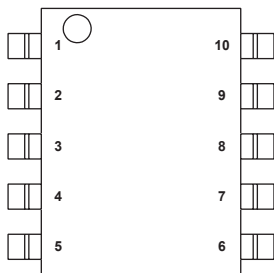

PIN #	NAME	FUNCTION
1	CHF	High frequency oscillator capacitor/clock input
2	CLF	Lamp frequency capacitor/clock input
3	E	System enable: Wave-shaping resistor control
4	DCH	Wave-shaping discharge control
5	GND	System ground connection
6	N/C	
7	L-	Negative input to inductor
8	V _{OUT}	High voltage AC output to lamp
9	L+	Positive input to inductor
10	V+	DC power supply input

Note: Please consult factory for bare die dimensions and bond pad locations.

Typical Performance Characteristics Using Standard Test Circuit

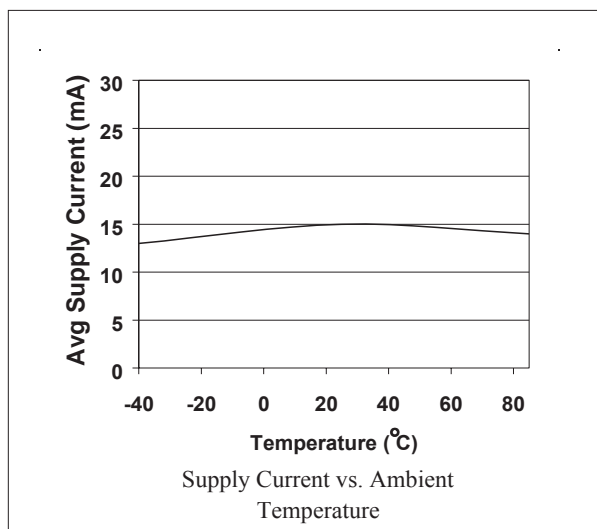
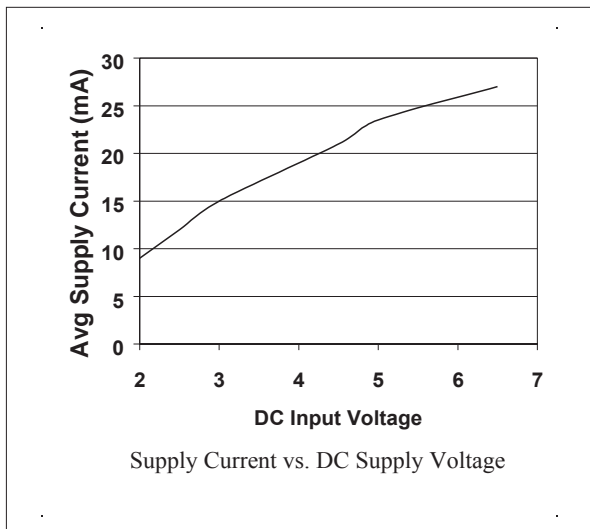
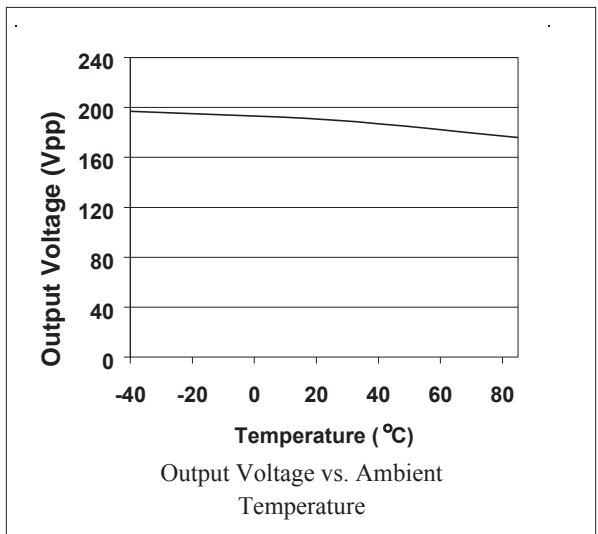
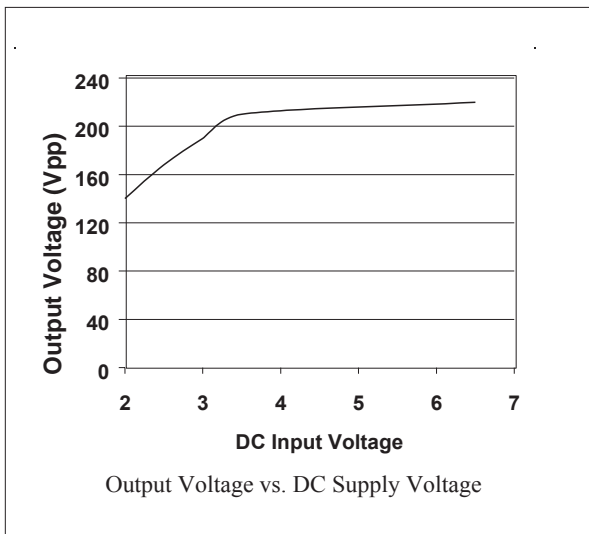
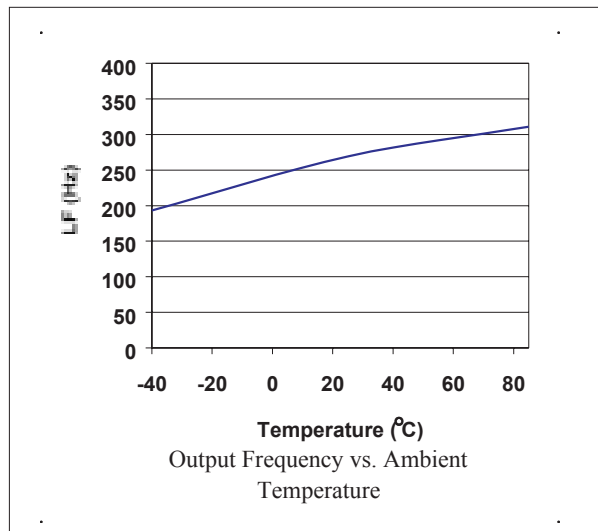
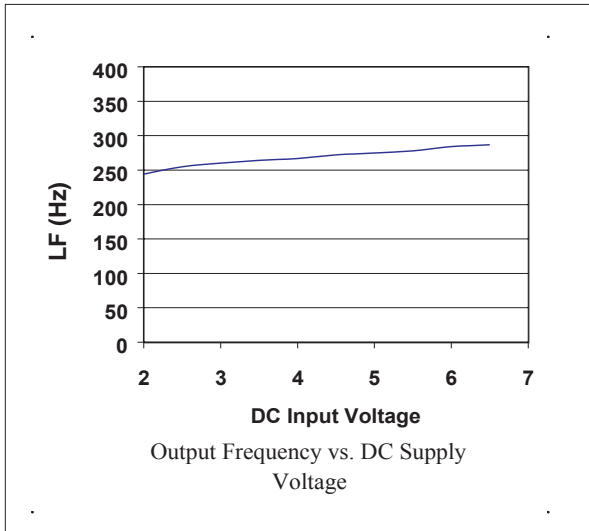

Block Diagram of the Driver Circuitry

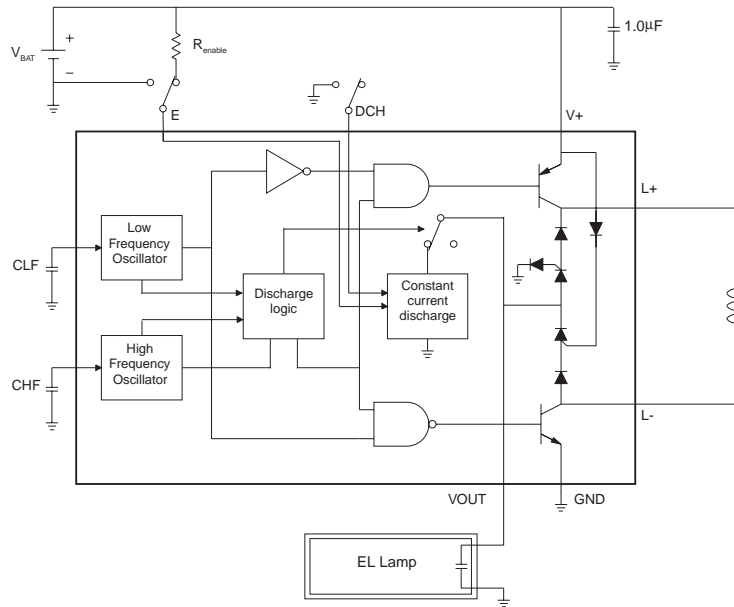

Theory of Operation

Electroluminescent (EL) lamps are essentially capacitors with one transparent electrode and a special phosphor material in the dielectric. When a strong AC voltage is applied across the EL lamp electrodes, the phosphor glows. The required AC voltage is typically not present in most systems and must be generated from a low voltage DC source. Thus, Durel developed its patented Three-Port (3P) switch-mode driver circuit to convert the available DC supply to an optimal drive signal for high brightness and low-noise EL lamp applications. The Durel 3P topology offers the simplicity of a single DC input, single AC output, and a shared common ground that provides an integrated EMI shielding.

The D371 drives the EL lamp by repeatedly pumping charge through an external inductor with current from a DC source and discharging into the capacitance of the EL lamp load. With each high frequency (HF) cycle the voltage on the lamp is increased. At a period specified by the lamp frequency (LF) oscillator, the voltage on the lamp is discharged to ground and the polarity of the inductive charging is reversed. By this means, an alternating positive and negative voltage is developed at the single output lead of the device to one of the electrodes of the EL lamp. The other lamp electrode is commonly connected to a ground plane, which can then be considered as electrical shielding for any underlying circuitry in the application.

The EL driving system is divided into several parts: on-chip logic and control, on-chip high voltage output circuitry, discharge logic circuitry, and off-chip components. The on-chip logic controls the lamp operating frequency (LF), as well as the inductor switching frequency (HF), and HF and LF duty cycles. These signals are combined and buffered to regulate the high voltage output circuitry. The output circuitry handles the power through the inductor and delivers the high voltage to the lamp. The integrated discharge logic circuit enables the low-noise functionality of this EL driver with four levels of discharge slopes on the output waveform. The selection of off-chip components provides a degree of flexibility to accommodate various lamp sizes, system voltages, and brightness levels. Since a key objective for EL driver systems is to save space and cost, required off-chip components were kept to a minimum.

Durel provides a D371 Designer's Kit, which includes a printed circuit evaluation board intended to aid you in developing an EL lamp driver configuration using the D371 that meets your requirements. A section on designing with the D371 is included in this datasheet to serve as a guide to help you select the appropriate external components to complete your D371 EL driver system.

Typical D371 configurations for driving EL lamps in various applications are shown on the following page. The expected system outputs, such as lamp luminance, lamp output frequency and voltage, and average supply current draw, for the various sample configurations are also shown with each respective figure.

Typical D371 EL Driver Configurations

3.0V Handset LCD

Typical Output

Luminance = 5.0 fL (17 cd/m²)
 Lamp Frequency = 330 Hz
 Supply Current = 19 mA
 Vout = 210 Vpp
 Load = 1.5 in² (950 mm²) Durel ®3 Green EL

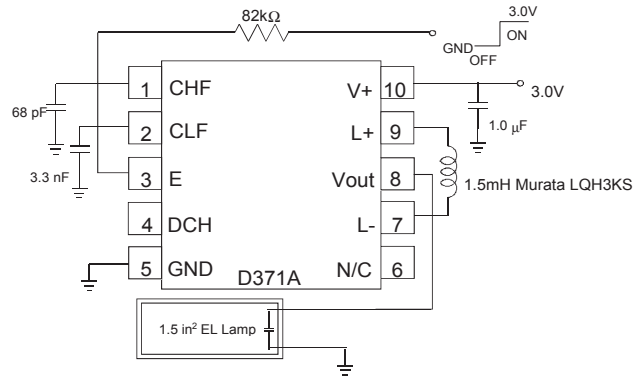

3.3V Handset LCD & Keypad

Typical Output

Luminance = 6.5 fL (22 cd/m²)
 Lamp Frequency = 270 Hz
 Supply Current = 15 mA
 Vout = 190 Vpp
 Load = 2.4 in² (1550 mm²) Durel ®3 Green EL

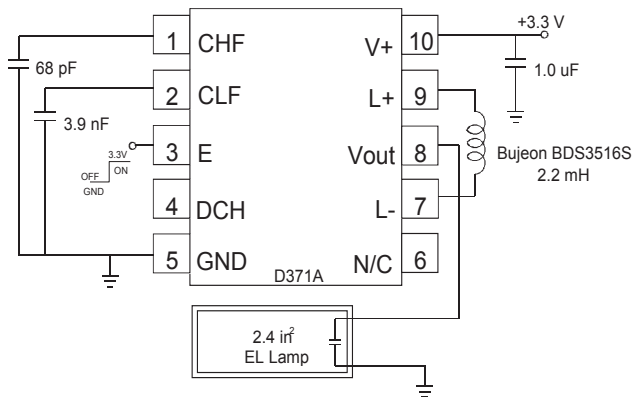

5.0V PDA

Typical Output

Luminance = 5.5 fL (19 cd/m²)
 Lamp Frequency = 285 Hz
 Supply Current = 15 mA
 Vout = 200 Vpp
 Load = 4 in² (2580 mm²) Durel ® 3 Green EL

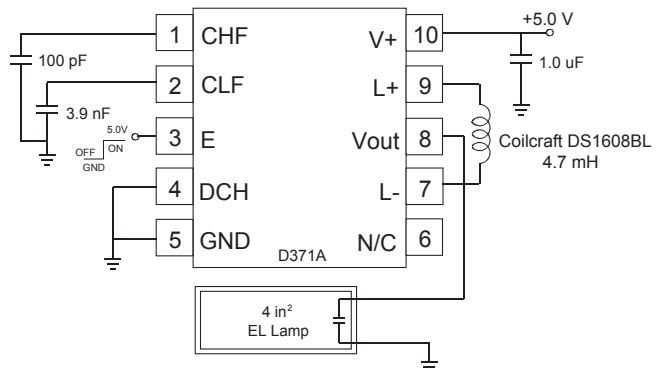

Designing With D371A

I. Lamp Frequency Capacitor (CLF) Selection

Selecting the appropriate value of lamp frequency capacitor (CLF) for the low frequency oscillator will specify the output frequency of the D371 EL driver. Lamp frequencies of 200-500Hz are typically used. Figure 1 graphically represents the inversely proportional relationship between the CLF capacitor value and the oscillator frequency. In this example at $V^+=3.0V$, $LF = 1150 \text{ nF-Hz/CLF}$.

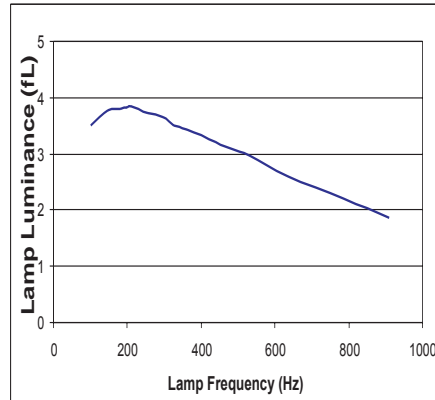

Figure 1: Typical Lamp Frequency vs. CLF Capacitor

Alternatively, the lamp frequency may also be controlled with an external clock signal with a typical duty cycle of 75%. There is an internal frequency divider in the device so that the output lamp frequency will be half of the input clock signal. For example, if a 500Hz input clock signal is used, the resulting lamp frequency will be 250Hz. The clock signal input voltage should not exceed V^+ .

The selection of the CLF value can also affect the brightness of the EL lamp because of its control of the lamp frequency (LF). Although input voltage and lamp size can change EL lamp frequency as well, LF mainly depends on the CLF value selected or the frequency of the input clock signal to CLF. Figure 2 shows typical brightness of a D371 circuit with respect to lamp frequency. In this example, the inductor and CHF values were kept constant while varying LF.

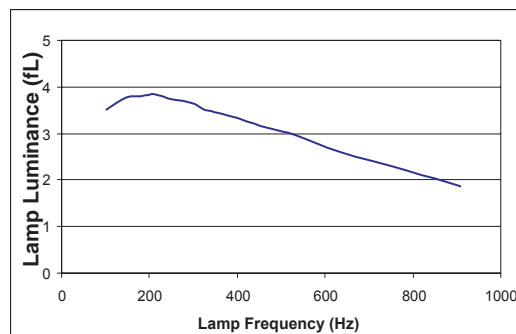

Figure 2: Typical Lamp Luminance vs. Lamp Frequency
($V^+ = 3.0V$, 2.4 in^2 Durel 3 Green EL Lamp Load)

II. High Frequency Capacitor (CHF) Selection

Selecting the appropriate value of capacitor for the high frequency oscillator (CHF) will set the inductor switching frequency of the D371 IC. High inductor frequency allows for more efficient use of inductor coils with lower values. However, care must be taken that the charge pumping does not reach a continuous mode at very high frequency when the voltage is not efficiently transferred to the lamp load. Figure 3 graphically represents the effect of the CHF value on the oscillator frequency at $V^+ = 3.0V$.

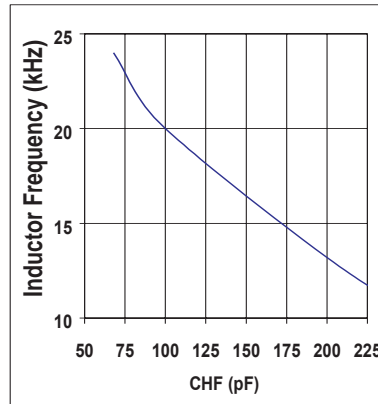

Figure 3: Typical Inductor Frequency vs. CHF Capacitor

The inductor switching frequency may also be controlled with an external clock signal. The inductor will charge during the low portion of the clock signal and discharge into the EL lamp during the high portion of the clock signal. The positive duty cycle used for the external high frequency clock signal is usually between 15%-75% with a typical value of 15%-20% for maximum brightness. The clock signal input voltage should not exceed V^+ .

III. Inductor (L) Selection

The inductor value and inductor switching frequency have the greatest impact on the output brightness and current consumption of the EL driver. Figures 4 and 5 show the dependence of brightness and current draw of a D371 circuit on coil values and CHF values for two sample EL lamp sizes and input voltages. The CLF value was modified in each case such that the output voltage was approximately 190Vpp. Please note that the DC resistance (DCR) of inductors with the same nominal inductance value may vary with manufacturer and inductor type. Thus, inductors made by a different manufacturer may yield different outputs, but the trend of the different curves should be similar.

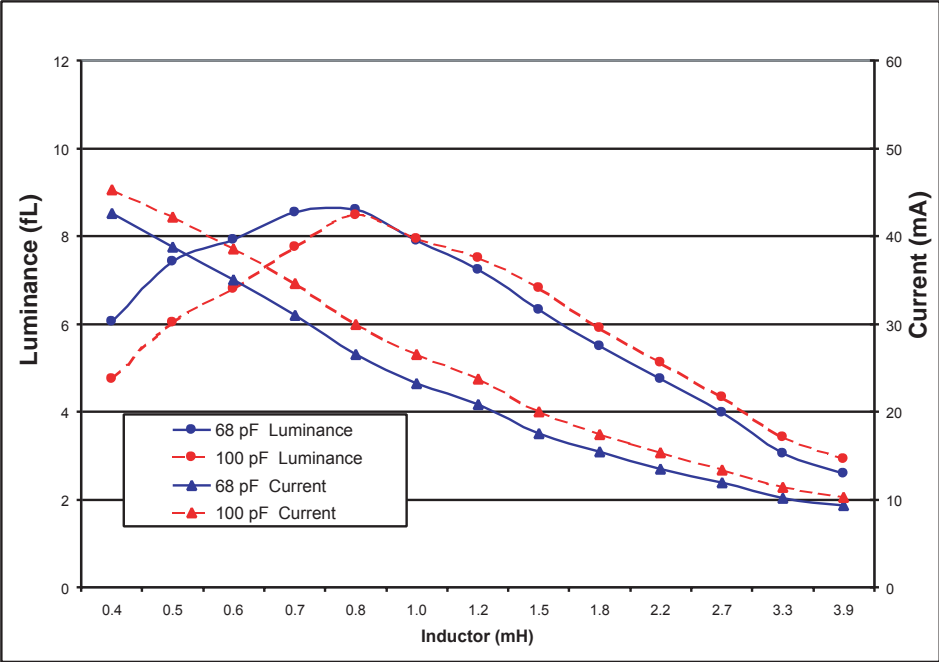

Figure 4: Luminance and current vs. inductor and CHF value.
(Conditions: $V_{+}=3.0V$, 2in² EL Lamp)

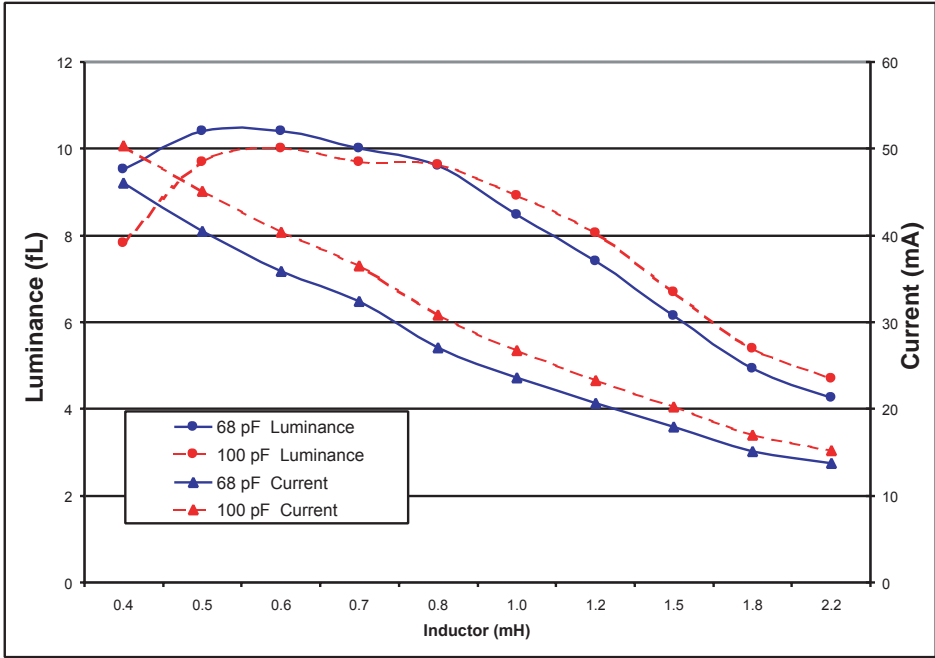

Figure 5: Luminance and current vs. inductor and CHF value.
(Conditions: $V_{+}=5.0V$, 4in² EL Lamp)

IV. Wave-Shape Selection

The D371 driver IC uses a patented wave-shaping technique for reducing audible noise from an EL lamp. The linear discharge of the output waveform may be adjusted by selecting one of 4 lamp discharge levels. The optimal discharge level for an application depends on the lamp size, lamp brightness, and application conditions. To ensure that the D371 is configured optimally, each level should be evaluated. In many cases, the lower discharge levels result in lower audible noise from the EL lamp.

Discharge level	Renable	DCH pin	Typical Lamp Size
1 (slowest)	80k Ω	Open	0.1 - 2 in ²
2	0 Ω	Open	1.0 - 3.5 in ²
3	80k Ω	GND	3.5 - 5 in ²
4 (fastest)	0 Ω	GND	>5 in ²

Typical waveshapes corresponding to the various discharge levels for a small size lamp and a larger size lamp are shown below. In each case, the waveshape with the smoothest transition slopes in the discharge portion of the waveform yields the lowest audible noise.

1in² EL Lamp

Discharge Level 1 (lowest noise)

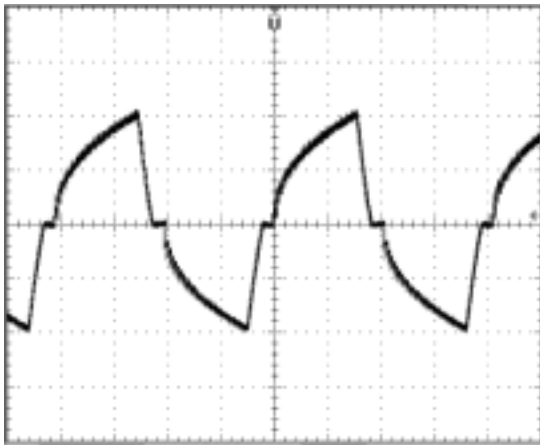

Discharge Level 4

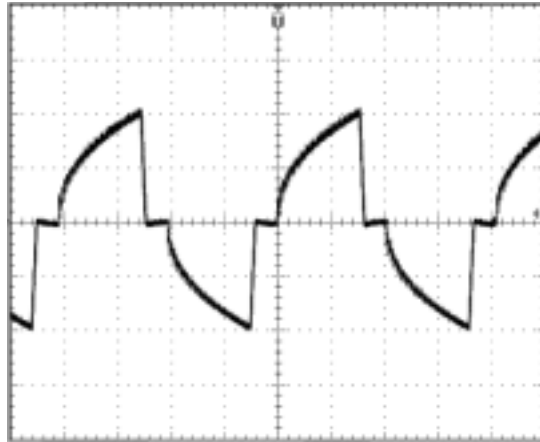

8in² EL Lamp

Discharge Level 2

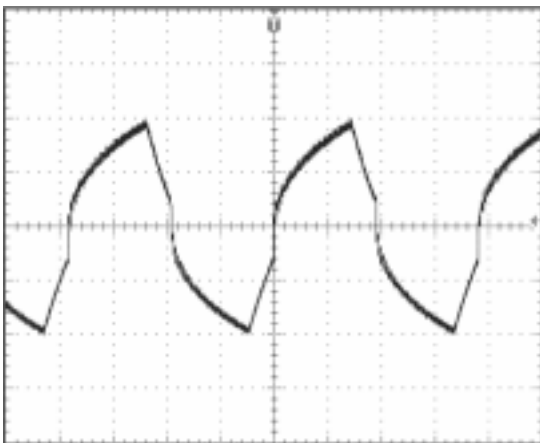

Discharge Level 4 (lowest noise)



D371 Design Ideas

I. Driving Multiple EL Lamps

The D371 may be used to drive multiple EL lamp segments. An external transistor switching circuit is used to turn each lamp segment on or off independently or simultaneously. A high signal at the corresponding E input will enable the corresponding lamp segment. In this configuration, EL Lamp 1 is always turned on when the IC is enabled. Otherwise, always make sure that at least one lamp segment is selected to be on when the D371 is enabled.

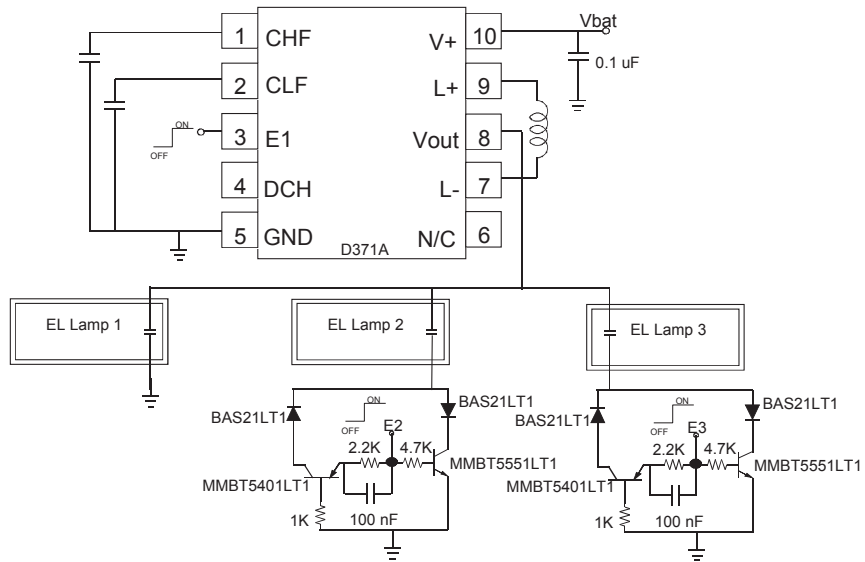

II. Two Level Dimming

Two level dimming may be achieved with the circuit below. When DIM is low, the external PNP transistor (2N3906 or equivalent) is saturated and the EL lamp runs at full brightness. When DIM is high, the external PNP turns off and the Rswitch resistor reduces the voltage at (V+) and dims the EL lamp.

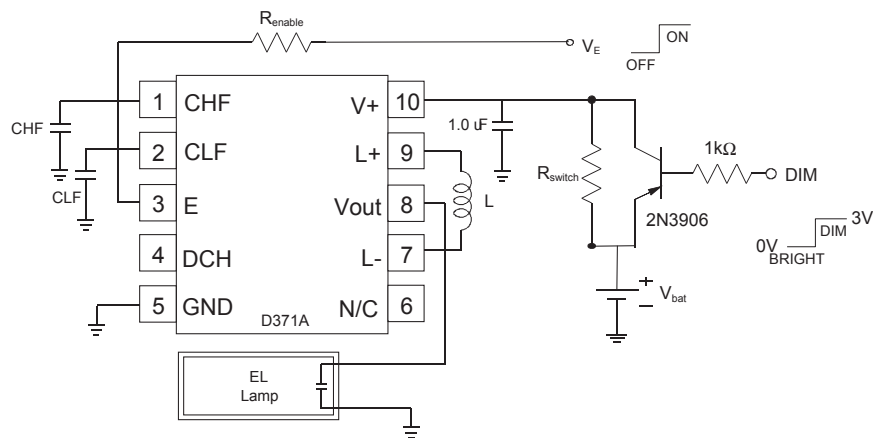

III. Lamp Frequency Control with an External Clock Signal

An external clock signal may be used to control the EL lamp frequency (LF) of the D371A instead of using a capacitor. There is an internal frequency divider in the IC so that the output lamp frequency will be half of the input clock signal. For example, if a 500Hz input clock signal is used, the resulting lamp frequency will be 250Hz. The clock signal voltage should not exceed $V+$. A typical duty cycle for the clock input is +75%, but it can also be adjusted within a range of 20% to 99% to control brightness and discharge level. A higher positive duty cycle allows for longer charge time and peak voltage, at the expense of a faster discharge slope and higher noise.

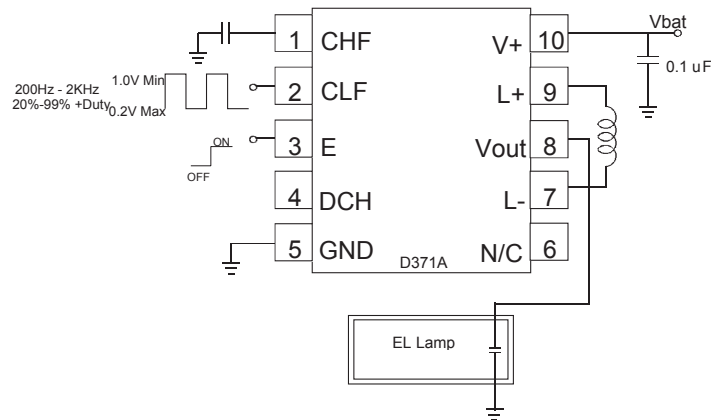

IV. EL Brightness Control Through HF Clock Pulse Width Modulation

The inductor oscillating frequency may also be controlled on the D371A EL driver IC using an external clock input to CHF. In addition, pulse-width modulation of the external HF clock signal to the D371 may be used to regulate the brightness of the EL lamp load. High frequency input is typically in the range of 10kHz to 40kHz, with duty cycle in the range of 15% to 100%. In general, a lower HF frequency results in higher brightness and using a lower duty cycle results in higher brightness. The clock signal voltage should not exceed $V+$. Prior to finalization of the circuit, contact Durel to verify that the frequency, duty cycle, and setup chosen are acceptable for EL driver performance.

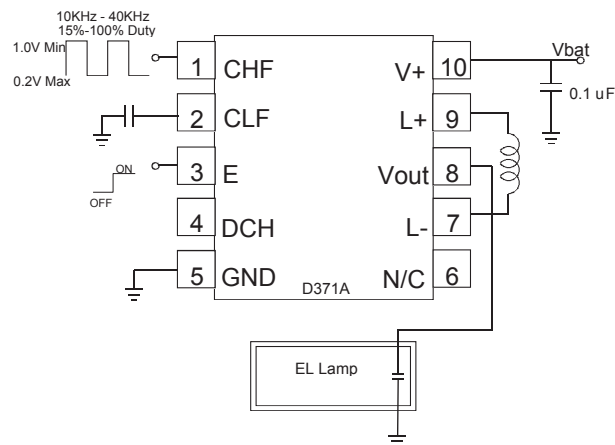

V. EL Lamp Brightness Regulation

Regulating the DC supply input voltage to the D371 will result in a constant brightness level from the EL lamp, regardless of battery voltage. In this example, a Micrel voltage regulator is used.

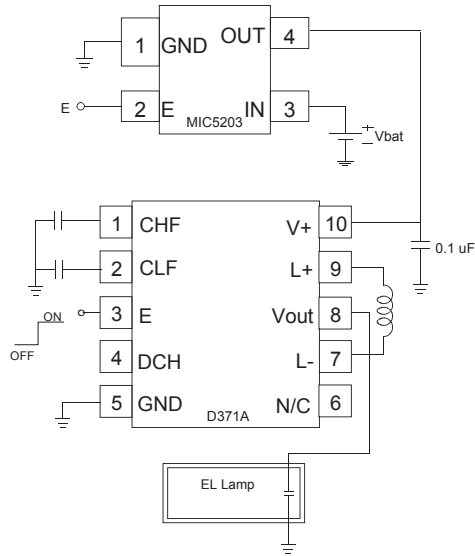

VI. Output Voltage Limiting

An EL driver system using the D371 driver IC should be designed such that the output voltage does not exceed the maximum rated value of 220Vpp. A pair of zener diodes connected to the output as shown below is recommended to limit Vout to within 200Vpp or less. This circuit protects the device from over-voltage when typical performance is near the maximum limit for the D371.

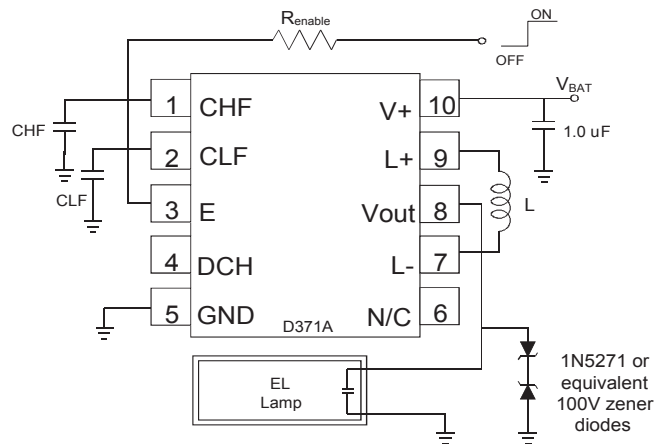

D371A Application Testing Recommendations

The following recommendations should be considered when testing the D371A device to ensure that the devices are not damaged.

- 1) Do not perform any no load test. If no load test is required, please contact Durel Corporation on proper test procedure.
- 2) Place 100V Zener diodes on the Vout pin to ground to prevent exceeding the maximum rated output (220Vpp). Zener diodes will clamp output voltage to 200Vpp. See diagram below.
- 3) It has been found that DC transient voltages applied to the Vout pin of the D371A while in operation can cause internal damage. Built up charge can sometimes be found on an EL Lamp or dummy load test fixture. This built up charge can act as a DC transient. Place a high value resistor (value depending on RC time constant) in parallel with EL lamp or dummy load to allow built up charge to discharge properly. See diagram below.

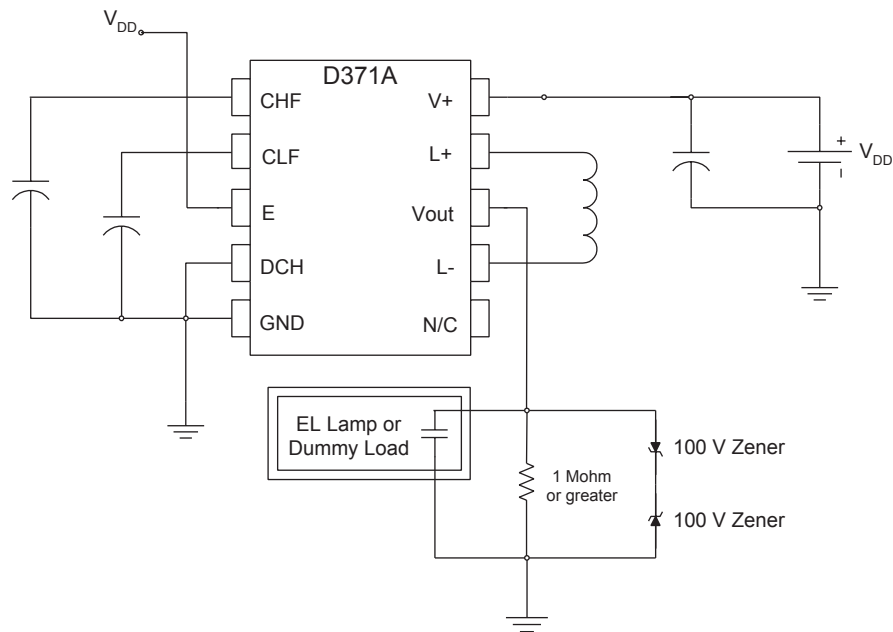

Ordering Information

The D371A IC is available as bare die in probed wafer form or in die tray, and in standard MSOP-10 plastic package per tape and reel. A Durel D371 Designer's Kit (1DDD371AA-K01) provides a vehicle for evaluating and identifying the optimum component values for any particular application using D371. Durel engineers also provide full support to customers, including specialized circuit optimization and application retrofits.

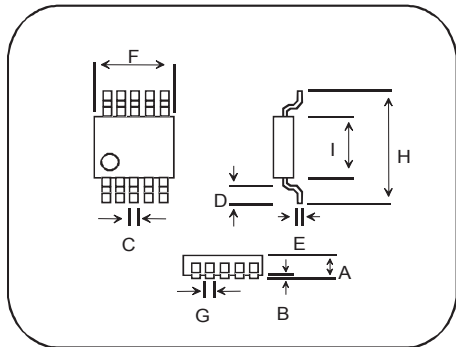

Description	MSOP-10					
	Min.		Typical		Max.	
	mm.	in.	mm.	in.	mm.	in.
A	0.92	0.036	1.00	0.039	1.08	0.043
B	0.05	0.002	0.10	0.004	0.15	0.006
C	0.15	0.006	0.23	0.009	0.31	0.012
D	0.40	0.016	0.55	0.022	0.70	0.028
E	0.13	0.005	0.18	0.007	0.23	0.009
F	2.90	0.114	3.00	0.118	3.10	0.122
G	0.35	0.014	0.50	0.020	0.65	0.026
H	4.75	0.187	4.90	0.193	5.05	0.199
I	2.90	0.114	3.00	0.118	3.10	0.122

MSOPs are marked with part number (371A) and 3-digit wafer lot code. Bottom of marking is on the Pin 1 side.

RECOMMENDED PAD LAYOUT

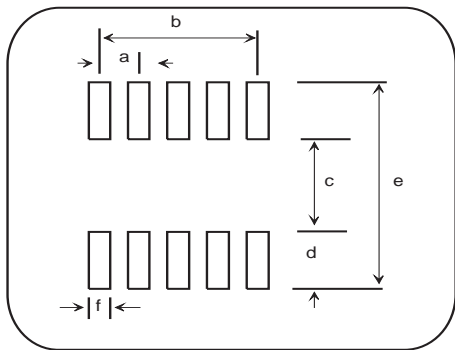

	MSOP-10 PAD LAYOUT					
	Min.		Typical		Max.	
	mm.	in.	mm.	in.	mm.	in.
a			0.5	0.0197		
b			2.0	0.0788		
c	3.3	0.130			3.45	0.136
d	0.89	0.035	0.97	0.038	1.05	0.041
e	5.26	0.207			5.41	0.213
f			0.3	0.012		

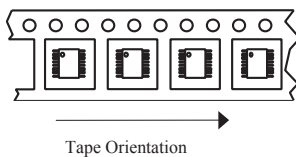

MSOPs in Tape and Reel: 1DDD371AA-M04

Embossed tape on 360 mm diameter reel per EIA-481-2.
2500 units per reel. Quantity marked on reel label.

ISO 9001 Certified

DUREL Corporation

2225 W. Chandler Blvd.

Chandler, AZ 85224-6155

Tel: (480) 917-6000

FAX: (480) 917-6049

Website: <http://www.durel.com>

The DUREL name and logo are registered trademarks of DUREL CORPORATION.

This information is not intended to and does not create any warranties, express or implied, including any warranty of merchantability or fitness for a particular purpose. The relative merits of materials for a specific application should be determined by your evaluation.

The EL driver circuits herein are covered by one or more of the following patents: #5,313,141; #5,347,198; #5,789,870.; 6,259,619. Corresponding foreign patents are issued and pending.

© 2000, 2001 Durel Corporation

Printed in U.S.A.

LIT-19028 Rev. A10