

FILTER IC FOR Σ - Δ MODULATION SYSTEM DA CONVERTER

KIA2028F an analog filter IC for Σ - Δ modulation system DA converter.

Using the KIA2028F in combination the KIC9237BF, KIC9237BN (the Σ - Δ modulation system DA converter with a built-in digital filter), it is possible to construct a DA conversion system with less external parts.

FEATURES

- Built-in CR for LPFs and output (differential) amplifiers for the left and right channel.
- Single power supply operation.
(+9V operation : BS tuner system)
- Noise distortion factor and S/N ratio are as follows
(When operating at +5V single power supply) :
Noise distortion factor : -86dB (Typ.)
S/N : 100dB (Typ.)

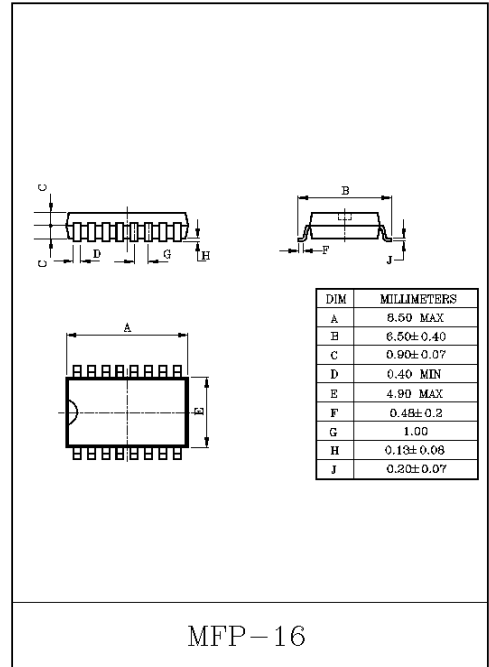

MAXIMUM RATINGS (Ta=25°C)

CHARACTERISTIC	SYMBOL	RATING	UNIT
Supply Voltage	V _{CC}	11	V
Power Dissipation	P _D (Note)	350	mW
Operating Temperature	T _{opr}	-25~75	°C
Storage Temperature	T _{stg}	-55~150	°C

(Note) Derated above Ta=25°C in the proportion of 200mW/°C for KIA2028F.

BLOCK DIAGRAM

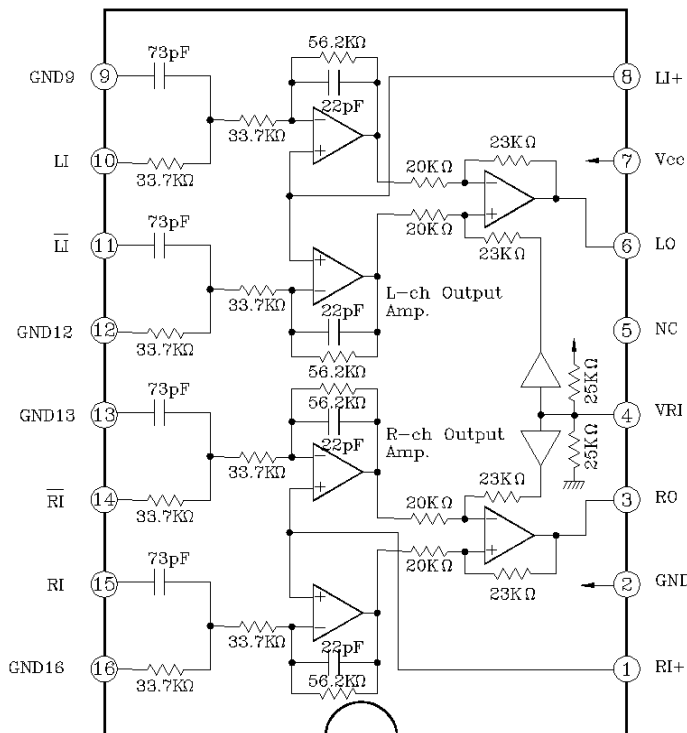

KIA2028F

DESCRIPTION OF PIN FUNCTIONS

PIN No.	SYMBOL	I/O	FUNCTION & OPERATION	REMARK
1	RI+	I	R channel operational amplifier forward input terminal. Connect to VRI.	-
2	GND	-	Ground terminal.	-
3	RO	O	R channel analog output terminal.	-
4	VRI	-	Reference voltage terminal. ($V_{CC}/2$)	See the block diagram
5	NC	-	Non-connecting terminal	-
6	LO	O	L channel analog output terminal.	-
7	V _{CC}	-	Supply voltage terminal.	-
8	LI+	I	L channel operational amplifier forward input terminal. Connect to VRI.	-
9	GND9	-	Ground terminal for L channel reverse input side filter.	-
10	LI	I	L channel forward input terminal.	Connect to LO of KIC9237BF, KIC9237BN
11	\overline{LI}	I	L channel reverse input terminal.	Connect to \overline{LO} of KIC9237BF, KIC9237BN
12	GND12	-	Ground terminal for L channel forward input side filter.	-
13	GND13	-	Ground terminal for R channel forward input side filter.	-
14	\overline{RI}	I	R channel reverse input terminal.	Connect to \overline{RO} of KIC9237BF, KIC9237BN
15	RI	I	R channel forward input terminal.	Connect to RO of KIC9237BF, KIC9237BN
16	GND16	-	Ground terminal for R channel reverse input side filter.	-

KIA2028F

ELECTRICAL CHARACTERISTICS (Unless otherwise specified, $V_{CC}=5V$, $T_a=25^{\circ}C$)

CHARACTERISTIC	SYMBOL	TEST CIRCUIT	TEST CONDITION	MIN.	TYP.	MAX.	UNIT
Operating Supply Voltage	V_{CC}	-	$T_a=-35\sim 85^{\circ}C$	8.0	9.0	10	V
Operating Supply Current	I_{CCQ}	-	At no signal	8.1	11.0	13.7	mA
Reference Voltage	VRI	-	-	4.4	4.5	4.6	V
Noise Distortion Factor	THD(1)	1	1kHz, $V_O=2mV_{rms}$	-	-86	-83	dB
	THD(2)		10kHz, $V_O=2mV_{rms}$	-	-86	-83	
	THD(3)		1kHz, $V_O=100mV_{rms}$	-	-74	-70	
Cross Talk	C.T.	1	1kHz, $V_O=2mV_{rms}$	-	-60	-90	dB
Attenuation	ATT(1)	1	40kHz, $V_O=-10dBV_{rms}$	0.51	0.71	1.41	dB
	ATT(2)		80kHz, $V_O=-10dBV_{rms}$	1.50	2.70	4.50	
Max. Output Level	V_{Omax}	1	1kHz, THD=1%	2.5	2.6	-	V_{rms}
Differential Balance	G_{VB}	1	1kHz, 1.1dBV _{rms} , In-phase input	-	-	-40	dB
LR Output Difference	G_{VD}	1	1kHz, 1.1dBV _{rms} , Differential input	-	0	0.5	dB

(Note1) When the KIC9237BF, KIC9237BN(+5V) and +9V single power supply are operated : Full scal=2mV_{rms}(Typ.)

(Note2) Measuring circuit-1 : indicates the measuring circuit.

TEST CIRCUIT 1

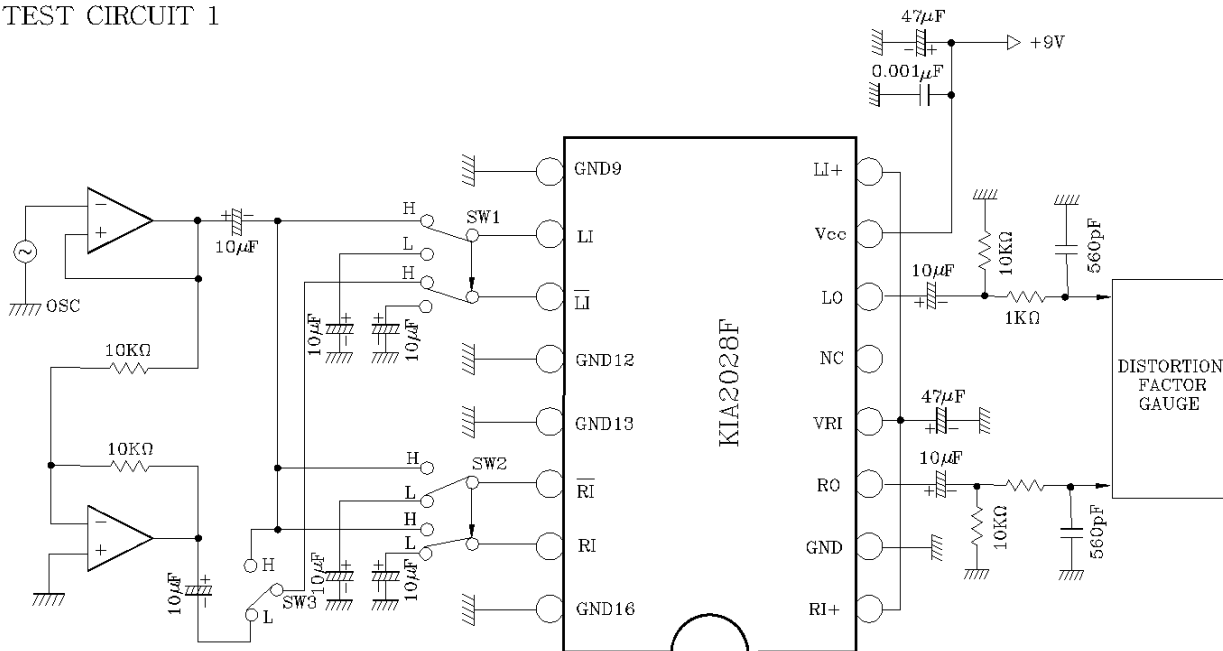

SW1	SW2	SW3	MEASURING ITEM
L	L	-	Operating supply voltage, Reference voltage
L	H	L	Cross talk (R→L)
H	L	L	Cross talk (L→R)
H	H	L	Noise distortion factor, Attenuation, Maximum output level, LR output difference
H	H	H	Difference balance

KIA2028F

APPLICATION CIRCUIT EXAMPLE

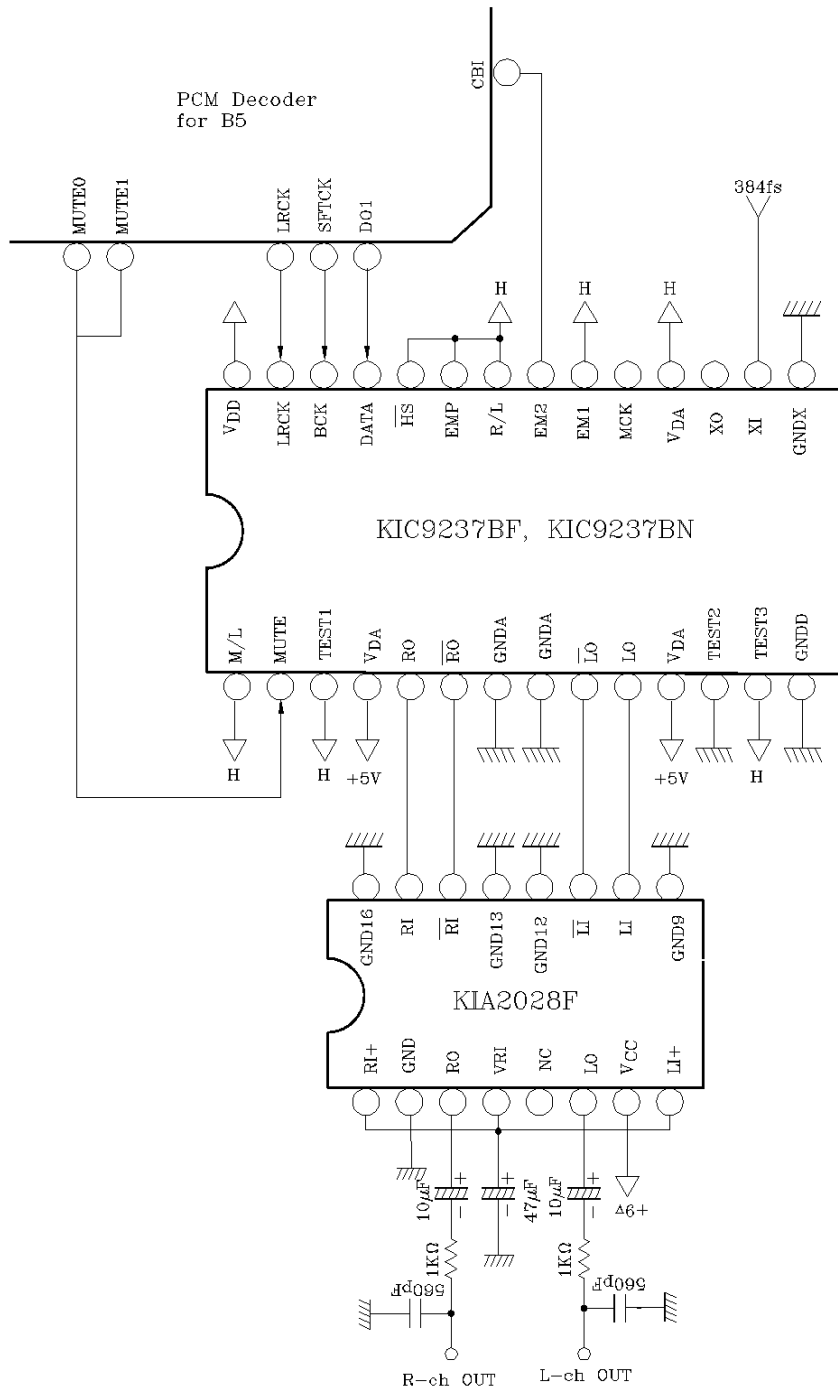

(CAUTIONS)

- Quality of crystal oscillation waveform largely effects S/N ratio. Further, this is also true when system clock is input externally through the XI terminal of pin⑥.
- Suppress diltch of input signals (LRCK, BCK, DATA) as could as possible.
- The wiring between the KIC9237BF, KIC9237BN output and the analog filter amplifier input must be made the shortest.
- The capacitor between V_{DA} and GND A shall be connected as close to the pin as possible.