



TO-251 Plastic-Encapsulate Transistors

3DD13002 TRANSISTOR (NPN)

FEATURES

Power dissipation

$$P_{CM} : 1.25 \text{ W (} T_{amb}=25 \text{)}$$

Collector current

$$I_{CM} : 1 \text{ A}$$

Collector-base voltage

$$V_{(BR)CBO} : 600 \text{ V}$$

Operating and storage junction temperature range

$$T_J, T_{stg}: -55 \text{ to } +150$$

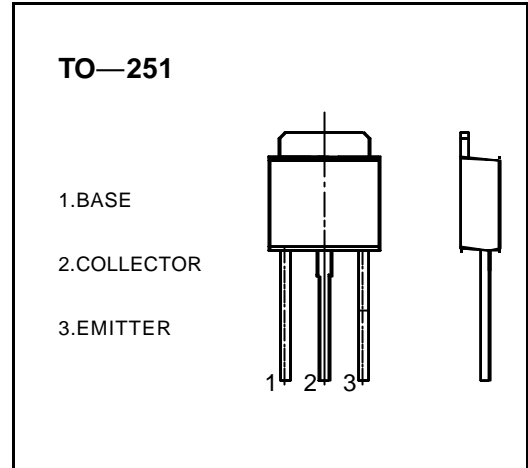

ELECTRICAL CHARACTERISTICS ($T_{amb}=25$ unless otherwise specified)

Parameter	Symbol	Test conditions	MIN	TYP	MAX	UNIT
Collector-base breakdown voltage	$V_{(BR)CBO}$	$I_C=100 \mu A, I_E=0$	600			V
Collector-emitter breakdown voltage	$V_{(BR)CEO}$	$I_C=1 \text{ mA}, I_B=0$	400			V
Emitter-base breakdown voltage	$V_{(BR)EBO}$	$I_E=100 \mu A, I_C=0$	6			V
Collector cut-off current	I_{CBO}	$V_{CB}=600 \text{ V}, I_E=0$			100	μA
Emitter cut-off current	I_{EBO}	$V_{EB}=6 \text{ V}, I_C=0$			100	μA
DC current gain	$h_{FE(1)}$	$V_{CE}=10 \text{ V}, I_C=200 \text{ mA}$	9		40	
	$h_{FE(2)}$	$V_{CE}=10 \text{ V}, I_C=250 \mu A$	5			
Collector-emitter saturation voltage	$V_{CE(sat)}$	$I_C=200 \text{ mA}, I_B=40 \text{ mA}$			0.8	V
Base-emitter saturation voltage	$V_{BE(sat)}$	$I_C=200 \text{ mA}, I_B=40 \text{ mA}$			1.1	V
Transition frequency	f_T	$V_{CE}=10 \text{ V}, I_C=100 \text{ mA}$ $f=1 \text{ MHz}$	5			MHz
Fall time	t_f	$I_C=1 \text{ A}, I_{B1}=-I_{B2}=0.2 \text{ A}$			0.5	μs
Storage time	t_s	$V_{CC}=100 \text{ V}$			2.5	μs

CLASSIFICATION OF $h_{FE(2)}$

Rank						
Range	9-15	15-20	20-25	25-30	30-35	35-40

Typical Characteristics

3DD13002

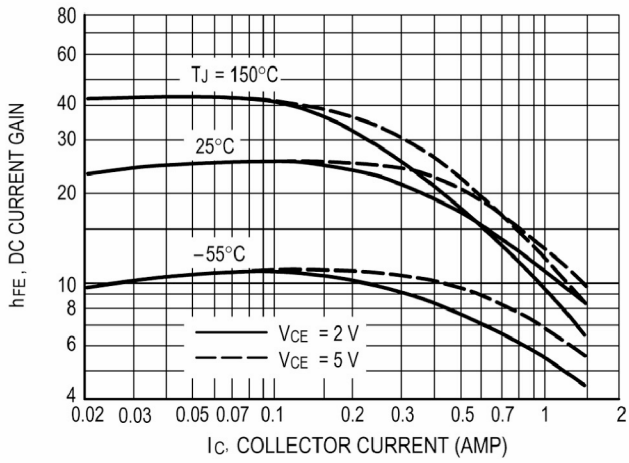

DC Current Gain

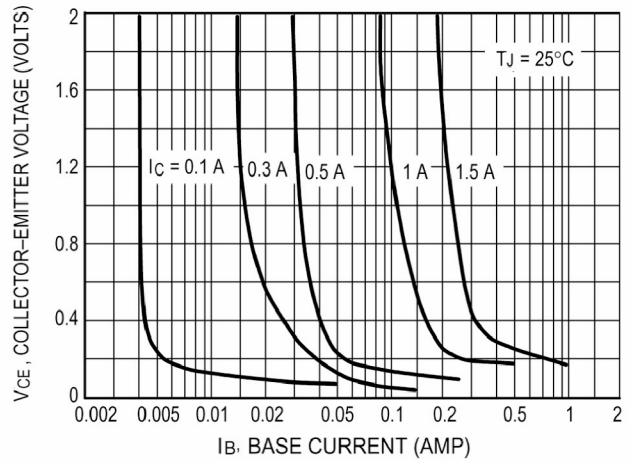

Collector Saturation Region

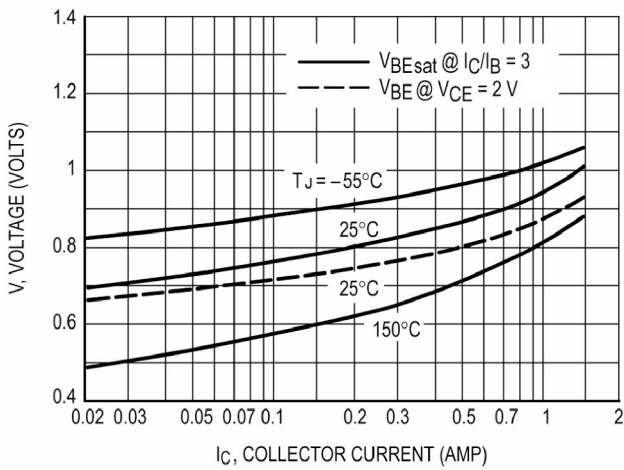

Base-Emitter Voltage

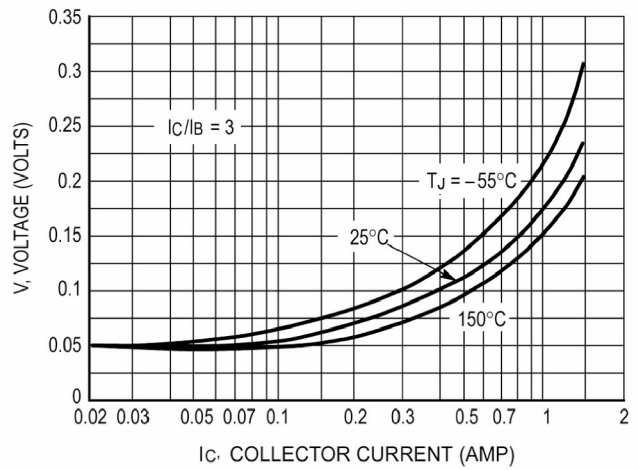

Collector-Emitter Saturation Region

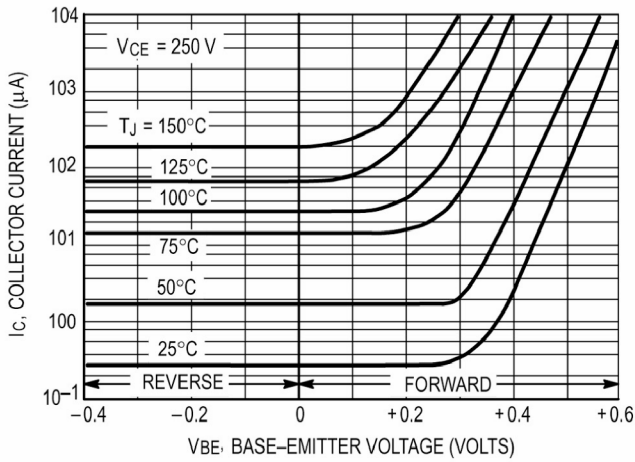

Collector Cutoff Region

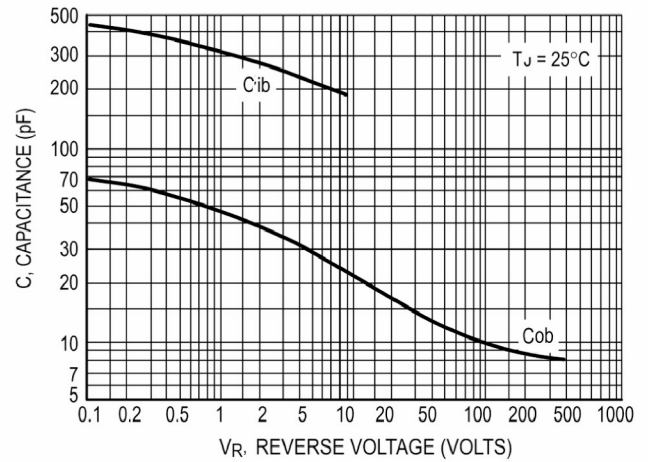

Capacitance

TO-251 PACKAGE OUTLINE DIMENSIONS

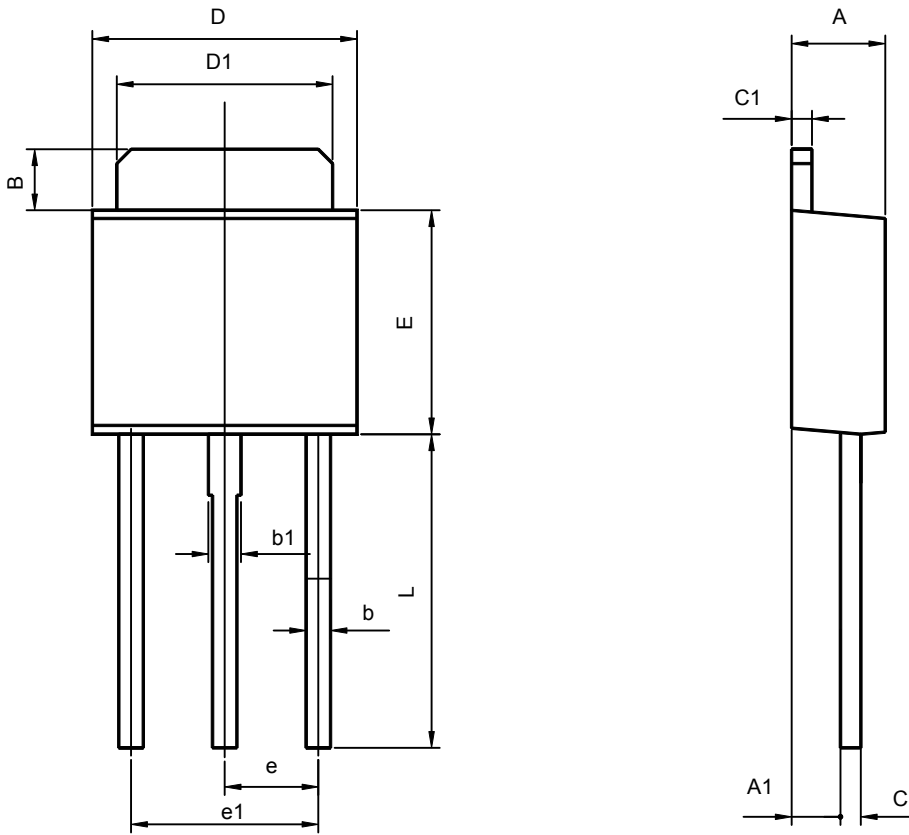

Symbol	Dimensions In Millimeters		Dimensions In Inches	
	Min	Max	Min	Max
A	2.200	2.400	0.087	0.094
A1	1.020	1.270	0.040	0.050
B	1.350	1.650	0.053	0.065
b	0.500	0.700	0.020	0.028
b1	0.700	0.900	0.028	0.035
c	0.430	0.580	0.017	0.023
c1	0.430	0.580	0.017	0.023
D	6.350	6.650	0.250	0.262
D1	5.200	5.400	0.205	0.213
E	5.400	5.700	0.213	0.224
e	2.300TYP		0.091TYP	
e1	4.500	4.700	0.177	0.185
L	7.500	7.900	0.295	0.311