



CAT24C00

128-Bit Serial EEPROM

FEATURES

- 400 kHz I²C bus compatible*
- 1.8 to 5.5 volt operation
- Low power CMOS technology
- Self-timed write cycle with auto-clear
- 1,000,000 Program/erase cycles
- 100 year data retention
- 8-pin DIP, 8-pin SOIC, 8 pin TSSOP and SOT-23
- Industrial and Extended Temperature Ranges

DESCRIPTION

The CAT24C00 is a 128-bit Serial CMOS EEPROM internally organized as 16 words of 8 bits each. Catalyst's advanced CMOS technology substantially reduces

device power requirements. The device operates via the I²C bus serial interface and is available in 8-pin DIP, 8-pin SOIC, 8-pin TSSOP and 5-pin SOT-23.

PIN CONFIGURATION

DIP Package (P, L, GL)

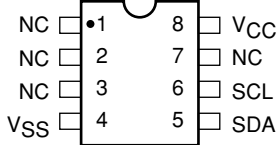

SOIC Package (J, W, GW)

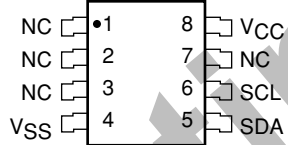

SOT-23 (TP, TB, GTB)

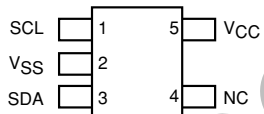

TSSOP Package (U, Y, GY)



PIN FUNCTIONS

Pin Name	Function
SDA	Serial Data/Address
SCL	Serial Clock
NC	No Connect
V _{CC}	1.8 V to 5.5 V Power Supply
V _{SS}	Ground

BLOCK DIAGRAM

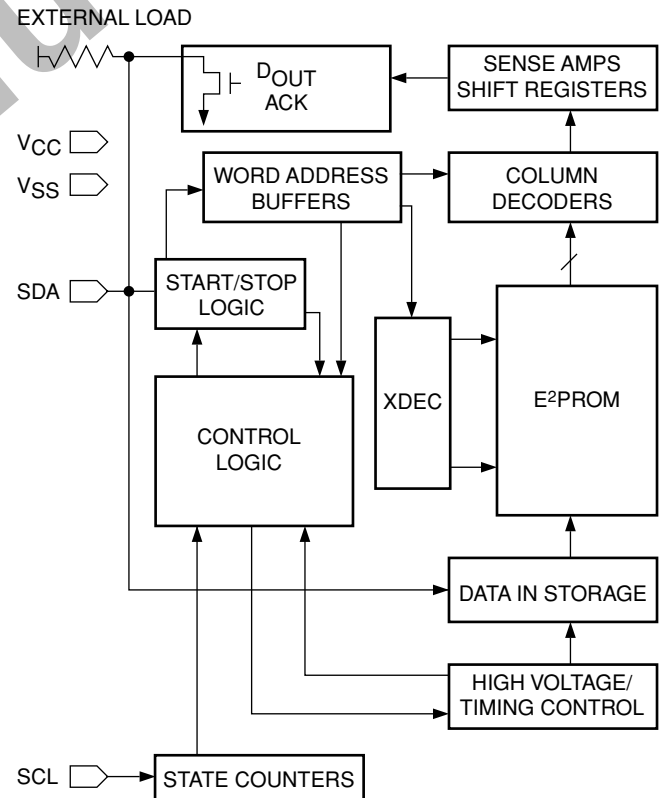

* Catalyst Semiconductor is licensed by Philips Corporation to carry the I²C Bus Protocol.

ABSOLUTE MAXIMUM RATINGS*

Temperature Under Bias	-55°C to +125°C
Storage Temperature	-65°C to +150°C
Voltage on Any Pin with Respect to Ground ⁽¹⁾	-2.0 V to $V_{CC} + 2.0$ V
V_{CC} with Respect to Ground	-2.0 V to +7.0 V
Package Power Dissipation Capability ($T_A = 25^\circ\text{C}$)	1.0 W
Lead Soldering Temperature (10 seconds)	300°C
Output Short Circuit Current ⁽²⁾	100 mA

***COMMENT**

Stresses above those listed under “Absolute Maximum Ratings” may cause permanent damage to the device. These are stress ratings only, and functional operation of the device at these or any other conditions outside of those listed in the operational sections of this specification is not implied. Exposure to any absolute maximum rating for extended periods may affect device performance and reliability.

RELIABILITY CHARACTERISTICS

Symbol	Parameter	Min.	Typ.	Max.	Units
$N_{END}^{(3)}$	Endurance	1,000,000			Cycles/Byte
$T_{DR}^{(3)}$	Data Retention	100			Years
$V_{ZAP}^{(3)}$	ESD Susceptibility	2000			Volts
$I_{LTH}^{(3)(4)}$	Latch-up	100			mA

D.C. OPERATING CHARACTERISTICS

$V_{CC} = 1.8$ V to 5.5 V, unless otherwise specified.

Symbol	Parameter	Test Conditions	Min	Typ	Max	Units
I_{CC}	Power Supply Current	$f_{SCL} = 400$ kHz			2	mA
$I_{SB}^{(5)}$	Standby Current ($V_{CC} = 5.0$ V)	$V_{IN} = \text{GND or } V_{CC}$			1	μA
I_{LI}	Input Leakage Current	$V_{IN} = \text{GND to } V_{CC}$			10	μA
I_{LO}	Output Leakage Current	$V_{OUT} = \text{GND to } V_{CC}$			10	μA
V_{IL}	Input Low Voltage		-1		$V_{CC} \times 0.3$	V
V_{IH}	Input High Voltage		$V_{CC} \times 0.7$		$V_{CC} + 0.5$	V
V_{OL1}	Output Low Voltage ($V_{CC} = 3.0$ V)	$I_{OL} = 3$ mA			0.4	V
V_{OL2}	Output Low Voltage ($V_{CC} = 1.8$ V)	$I_{OL} = 1.5$ mA			0.5	V

CAPACITANCE $T_A = 25^\circ\text{C}$, $f = 1.0$ MHz, $V_{CC} = 5$ V

Symbol	Parameter	Test Conditions	Min	Typ	Max	Units
$C_{I/O}^{(3)}$	Input/Output Capacitance (SDA)	$V_{I/O} = 0$ V			8	pF
$C_{IN}^{(3)}$	Input Capacitance (SCL)	$V_{IN} = 0$ V			6	pF

Note:

- (1) The minimum DC input voltage is -0.5 V. During transitions, inputs may undershoot to -2.0 V for periods of less than 20 ns. Maximum DC voltage on output pins is $V_{CC} + 0.5$ V, which may overshoot to $V_{CC} + 2.0$ V for periods of less than 20 ns.
- (2) Output shorted for no more than one second. No more than one output shorted at a time.
- (3) These parameter are tested initially and after a design or process change that affects the parameter according to appropriate AEC-Q100 and JEDEC test methods.
- (4) Latch-up protection is provided for stresses up to 100 mA on address and data pins from -1 V to $V_{CC} + 1$ V.
- (5) Maximum standby current (I_{SB}) = 10 μA for the Extended Automotive temperature range.

A.C. CHARACTERISTICS

V_{CC} = 1.8 V to 5.5 V, unless otherwise specified.

Read & Write Cycle Limits

Symbol	Parameter	1.8 V - 6.0 V		2.5 V - 6.0 V		Units
		Min	Max	Min	Max	
F_{SCL}	Clock Frequency		100		400	kHz
$T_I^{(1)}$	Noise Suppression Time Constant at SCL, SDA Inputs		100		100	ns
t_{AA}	SCL Low to SDA Data Out and ACK Out		3.5		1	μ s
$t_{BUF}^{(1)}$	Time the Bus Must be Free Before a New Transmission Can Start	4.7		1.2		μ s
$t_{HD:STA}$	Start Condition Hold Time	4		0.6		μ s
t_{LOW}	Clock Low Period	4.7		1.2		μ s
t_{HIGH}	Clock High Period	4		0.6		μ s
$t_{SU:STA}$	Start Condition Setup Time (for a Repeated Start Condition)	4.7		0.6		μ s
$t_{HD:DAT}$	Data In Hold Time	0		0		ns
$t_{SU:DAT}$	Data In Setup Time	50		50		ns
$t_R^{(1)}$	SDA and SCL Rise Time		1		0.3	μ s
$t_F^{(1)}$	SDA and SCL Fall Time		300		300	ns
$t_{SU:STO}$	Stop Condition Setup Time	4		0.6		μ s
t_{DH}	Data Out Hold Time	100		100		ns

Power-Up Timing⁽¹⁾⁽²⁾

Symbol	Parameter	Min	Typ	Max	Units
t_{PUR}	Power-up to Read Operation			1	ms
t_{PUW}	Power-up to Write Operation			1	ms

Write Cycle Limits

Symbol	Parameter	Min	Typ	Max	Units
t_{WR}	Write Cycle Time			5	ms

The write cycle time is the time from a valid stop condition of a write sequence to the end of the internal program/erase cycle. During the write cycle, the bus

interface circuits are disabled, SDA is allowed to remain high, and the device does not respond to its slave address.

Note:

(1) This parameter is tested initially and after a design or process change that affects the parameter.

(2) t_{PUR} and t_{PUW} are the delays required from the time V_{CC} is stable until the specified operation can be initiated.

FUNCTIONAL DESCRIPTION

The CAT24C00 supports the I²C Bus data transmission protocol. This Inter-Integrated Circuit Bus protocol defines any device that sends data to the bus to be a transmitter and any device receiving data to be a receiver. Data transfer is controlled by the Master device which generates the serial clock and all START and STOP conditions for bus access. The CAT24C00 operates as a Slave device. Both the Master and Slave devices can operate as either transmitter or receiver, but the Master device controls which mode is activated.

PIN DESCRIPTIONS

SCL: Serial Clock

The CAT24C00 serial clock input pin is used to clock all data transfers into or out of the device. This is an input pin.

SDA: Serial Data/Address

The CAT24C00 bidirectional serial data/address pin is used to transfer data into and out of the device. The SDA pin is an open drain output and can be wire-ORed with other open drain or open collector outputs.

I²C BUS PROTOCOL

The following defines the features of the I²C bus protocol:

- (1) Data transfer may be initiated only when the bus is not busy.
- (2) During a data transfer, the data line must remain stable whenever the clock line is high. Any changes in the data line while the clock line is high will be interpreted as a START or STOP condition.

Figure 1. Bus Timing

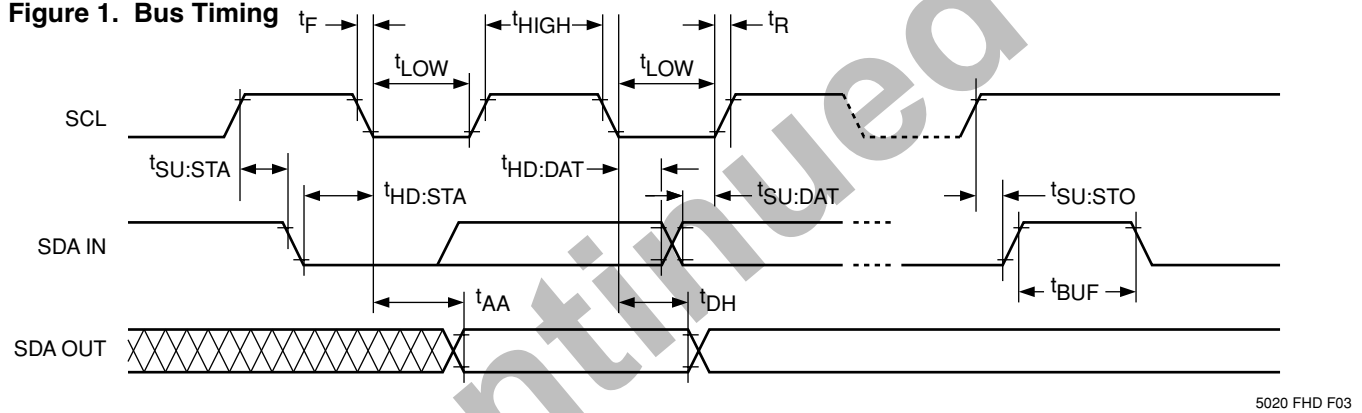

5020 FHD F03

Figure 2. Write Cycle Timing

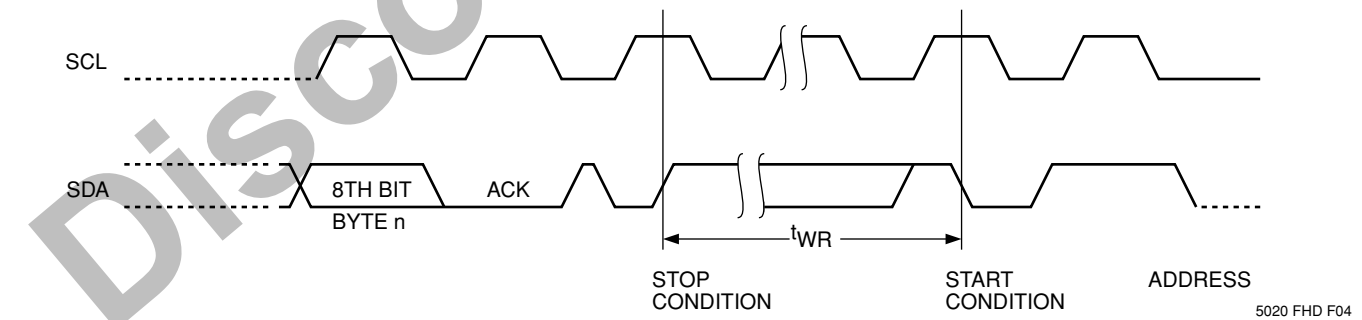

5020 FHD F04

Figure 3. Start/Stop Timing

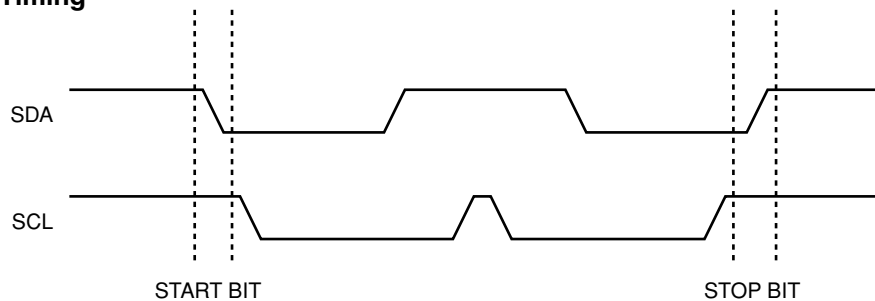

5020 FHD F05

START Condition

The START Condition precedes all commands to the device, and is defined as a HIGH to LOW transition of SDA when SCL is HIGH. The CAT24C00 monitors the SDA and SCL lines and will not respond until this condition is met.

STOP Condition

A LOW to HIGH transition of SDA when SCL is HIGH determines the STOP condition. All operations must end with a STOP condition.

DEVICE ADDRESSING

The bus Master begins a transmission by sending a START condition. The Master then sends the address of the particular slave device it is requesting. The four most significant bits of the 8-bit slave address are fixed as 1010 for the CAT24C00 (see Fig. 5). The next three significant bits are "don't care" bits. The last bit of the slave address specifies whether a Read or Write operation is to be performed. When this bit is set to 1, a Read operation is selected, and when set to 0, a Write operation is selected.

After the Master sends a START condition and the slave address byte, the CAT24C00 monitors the bus and responds with an acknowledge (on the SDA line) when its address matches the transmitted slave address. The CAT24C00 then performs a Read or Write operation depending on the state of the R/W bit.

Acknowledge

After a successful data transfer, each receiving device is required to generate an acknowledge. The Acknowledging device pulls down the SDA line during the ninth clock cycle, signaling that it received the 8 bits of data.

The CAT24C00 responds with an acknowledge after receiving a START condition and its slave address. If the device has been selected along with a write operation, it responds with an acknowledge after receiving each 8-bit byte.

When the CAT24C00 is in a READ mode it transmits 8 bits of data, releases the SDA line, and monitors the line for an acknowledge. Once it receives this acknowledge, the CAT24C00 will continue to transmit data. If no acknowledge is sent by the Master, the device terminates data transmission and waits for a STOP condition.

WRITE OPERATION

Byte Write

In the Write mode, the Master device sends the START condition and the slave address information (with the R/W bit set to zero) to the Slave device. After the Slave generates an acknowledge, the Master sends the byte address that is to be written into the address pointer of the CAT24C00. After receiving another acknowledge from the Slave, the Master device transmits the data byte to be written into the addressed memory location. The CAT24C00 acknowledges once more and the Master generates the STOP condition, at which time the device begins its internal programming cycle to nonvolatile memory. While this internal cycle is in progress, the device will not respond to any request from the Master device.

After a write command, the internal address counter will continue to point to the same address location that was just written. If a stop bit is transmitted to the device at any point in the write sequence before the entire sequence is complete, then the command will abort and no data will be written. If more than eight

Figure 4. Acknowledge Timing

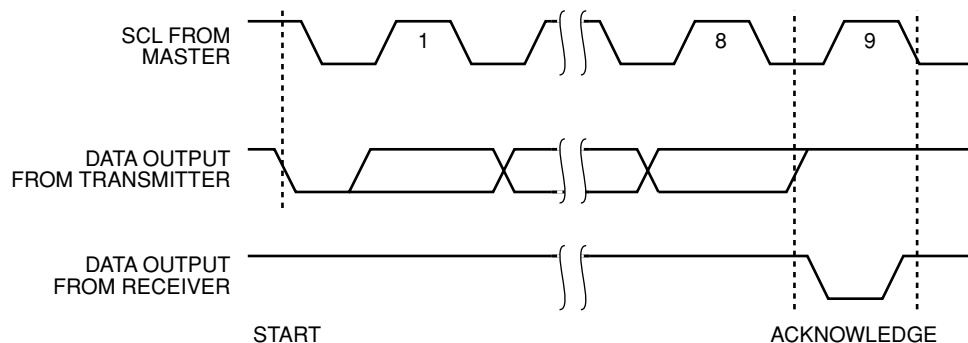

5020 FHD F06

Figure 5. Slave Address Bits

CAT24C00	1	0	1	0	X	X	X	R/ \bar{W}
----------	---	---	---	---	---	---	---	--------------

bits are transmitted before the stop bit is sent, then the device will clear the previously loaded byte and begin loading the data buffer again. If more than one data byte is transmitted to the device and a stop bit is sent before a full eight bits of data have been transmitted, then the write command will abort and no data will be written.

Acknowledge Polling

The disabling of the inputs can be used to take advantage of the typical write cycle time. Once the stop condition is issued to indicate the end of the host's write operation, the CAT24C00 initiates the internal write cycle. ACK polling can be initiated immediately. This involves issuing the start condition followed by the slave address for a write operation. If the CAT24C00 is still busy with the write operation, no ACK will be returned. If the CAT24C00 has completed the write operation, an ACK will be returned and the host can then proceed with the next read or write operation.

READ OPERATIONS

The READ operation for the CAT24C00 is initiated in the same manner as the write operation with the one exception that the R/ \bar{W} bit is set to a one. Three different READ operations are possible: Immediate Address READ, Selective READ and Sequential READ.

Immediate Address Read

The device's address counter contains the address of the last byte accessed, incremented by one. In other words, if the last READ access was to address N, the READ immediately following would access data from address N+1. If N=15, then the counter will 'wrap around' to address 0 and continue to clock out data.

Selective Read

Selective READ operations allow the Master device to select at random any memory location for a READ operation. The Master device first performs a 'dummy' write operation by sending the START condition, slave address and byte address of the location it wishes to read. After the CAT24C00 acknowledges the word address, the Master device resends the START condition and the slave address, this time with the R/ \bar{W} bit is set to one. The CAT24C00 then responds with its acknowledge and sends the 8-bit byte requested. To end the Read Operation the master device does not send an acknowledge but will generate a STOP condition.

Sequential Read

The Sequential READ operation can be initiated by either the immediate Address READ or Selective READ operations. After the CAT24C00 sends initial 8-bit byte requested, the Master will respond with an acknowledge which tells the device it requires more data. The CAT24C00 will continue to output an 8-bit byte for each acknowledge sent by the Master. The operation is terminated when the Master fails to respond with an acknowledge, thus sending the STOP condition.

The data being transmitted from the CAT24C00 is outputted sequentially with data from address N followed by data from address N+1. The READ operation address counter increments all of the CAT24C00 address bits so that the entire memory array can be read during one operation. If more than 16 bytes are read out, the counter will "wrap around" and continue to clock out data bytes.

Figure 6. Byte Write Timing

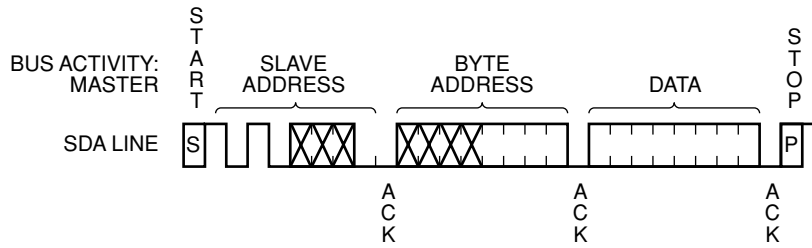

Figure 7. Immediate Address Read Timing

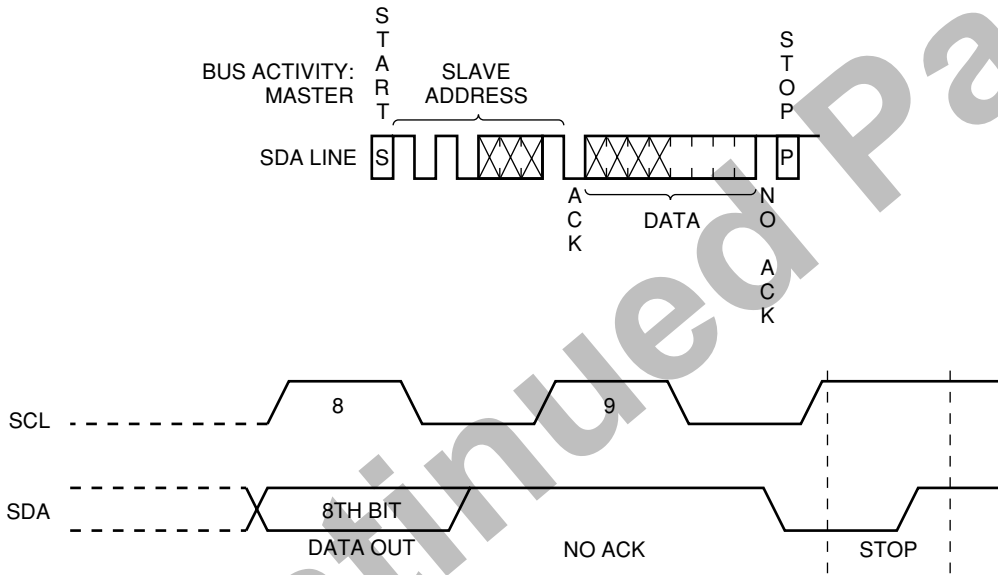

Figure 8. Selective Read Timing

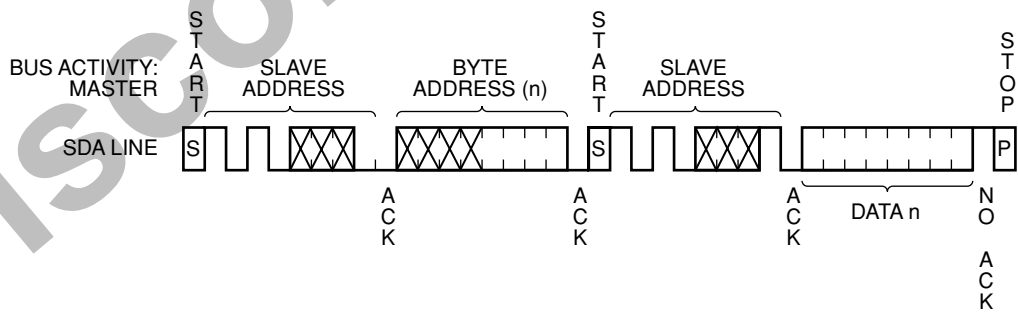
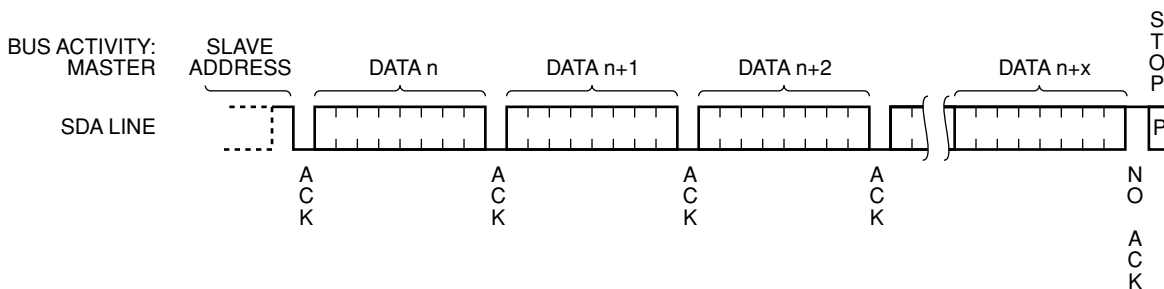
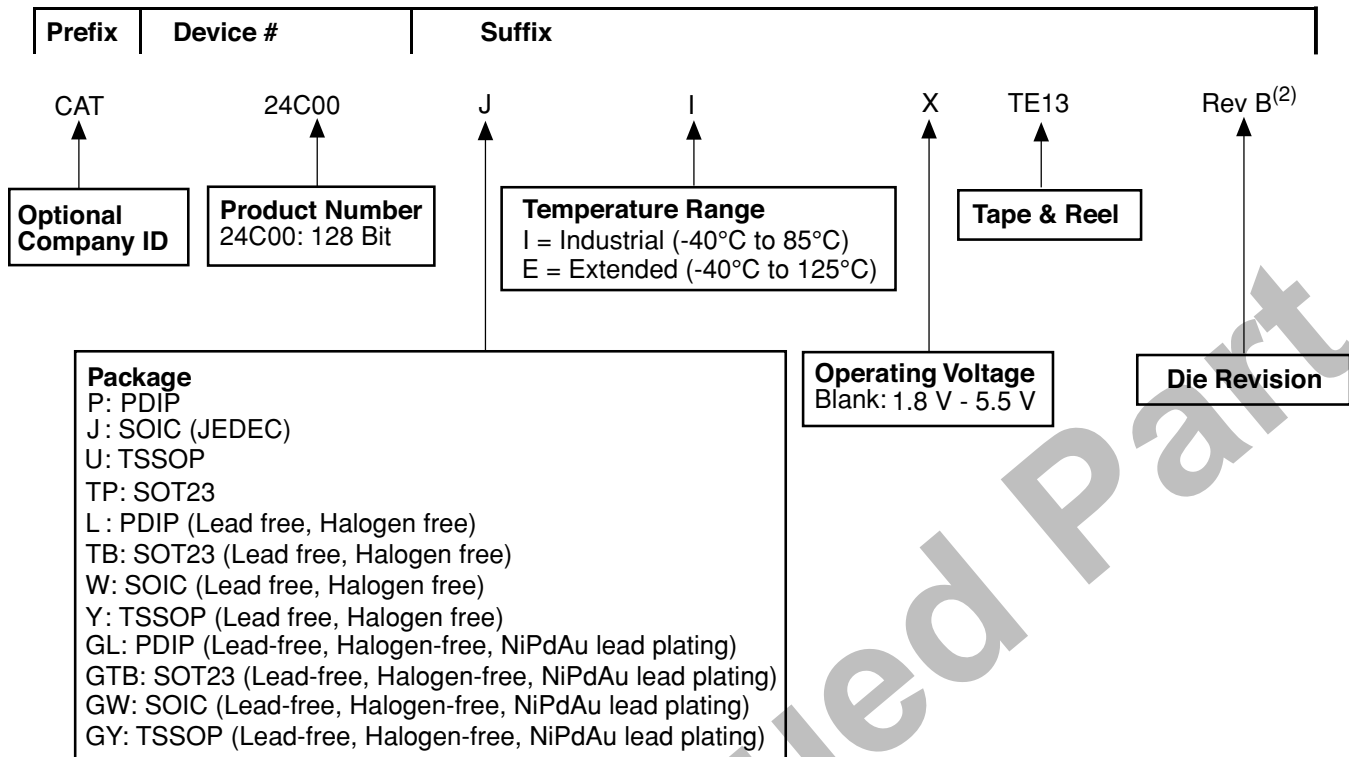

Figure 9. Sequential Read Timing



ORDERING INFORMATION



Notes:

- (1) The device used in the above example is a CAT24C00JI-TE13 (SOIC, Industrial Temperature, 1.8 Volt to 5.5 Volt Operating Voltage, Tape & Reel)
- (2) Product die revision letter is marked on top of the package as a suffix to the production date code (e.g. AYWWB). For additional information, please contact your Catalyst sales office.

REVISION HISTORY

Date	Rev.	Reason
9/24/2003	H	Eliminated commercial temperature range class Updated marking
10/30/2003	I	Eliminated automotive temperature reange
12/9/2003	J	Changed Industrial temp range designation from "Blank" to "I"
12/23/2003	K	Eliminatd Commercial and Automotive temp ranges from Features on front page of data sheet
12/29/2003	L	Moved DC Operating Characteristics typ numbers for VOL1 and VOL2 to max column Changed 1.8V to 1.8V - 6.0V for AC Characteristics Changed 4.5V - 5.5V to 2.5V - 6.0V for AC Characteristics
7/7/2004	M	Added Die Revision to Ordering Information
7/27/2004	N	Updated DC Operating Characteristics chart and notes
07/12/2005	O	U pate Rekiability Characteristics table Update Ordering Information

Discontinued Part

Copyrights, Trademarks and Patents

Trademarks and registered trademarks of Catalyst Semiconductor include each of the following:

DPP™ AE²™ MiniPot™

Catalyst Semiconductor has been issued U.S. and foreign patents and has patent applications pending that protect its products. For a complete list of patents issued to Catalyst Semiconductor contact the Company's corporate office at 408.542.1000.

CATALYST SEMICONDUCTOR MAKES NO WARRANTY, REPRESENTATION OR GUARANTEE, EXPRESS OR IMPLIED, REGARDING THE SUITABILITY OF ITS PRODUCTS FOR ANY PARTICULAR PURPOSE, NOR THAT THE USE OF ITS PRODUCTS WILL NOT INFRINGE ITS INTELLECTUAL PROPERTY RIGHTS OR THE RIGHTS OF THIRD PARTIES WITH RESPECT TO ANY PARTICULAR USE OR APPLICATION AND SPECIFICALLY DISCLAIMS ANY AND ALL LIABILITY ARISING OUT OF ANY SUCH USE OR APPLICATION, INCLUDING BUT NOT LIMITED TO, CONSEQUENTIAL OR INCIDENTAL DAMAGES.

Catalyst Semiconductor products are not designed, intended, or authorized for use as components in systems intended for surgical implant into the body, or other applications intended to support or sustain life, or for any other application in which the failure of the Catalyst Semiconductor product could create a situation where personal injury or death may occur.

Catalyst Semiconductor reserves the right to make changes to or discontinue any product or service described herein without notice. Products with data sheets labeled "Advance Information" or "Preliminary" and other products described herein may not be in production or offered for sale.

Catalyst Semiconductor advises customers to obtain the current version of the relevant product information before placing orders. Circuit diagrams illustrate typical semiconductor applications and may not be complete.



Catalyst Semiconductor, Inc.
Corporate Headquarters
1250 Borregas Avenue
Sunnyvale, CA 94089
Phone: 408.542.1000
Fax: 408.542.1200
www.caalyst-semiconductor.com

Publication #: 1027
Revision: O
Issue date: 7/12/05