

**Ultra Low Dropout
 Fixed Positive Linear Regulator**

**IRUH50P333A1M
 +5.0Vin to +3.3Vout at 3.0A**

Product Summary

Part Number	Dropout	I _O	V _{in}	V _{out}
IRUH50P333A1M	0.4V	3.0A	5.0V	3.3V



The IRUH50P333A1M is a space qualified, ultra low dropout linear regulator designed specifically for space applications. This product has been characterized to a total ionizing dose of 1.0 Mrad(Si) per MIL-STD-883, Method 1019 at both high and low dose rates under biased and unbiased conditions to account for ELDRS effects in bipolar devices. The ultra low dropout voltage of 0.4V@ 3A makes the part particularly useful for applications requiring low noise and higher efficiency.

Features:

- Total dose to 1.0 Mrad(Si) and low dose capability to 500 Krad(Si) allows use in space applications
- Single Event latchup Immune
 LET = 84 MeV/(mg/cm²)
 Fluency = 1 x 10⁹ ions/cm²
- Low noise, higher efficiency
- Ultra low dropout voltage of 0.4V@ 3A out significantly reduces power consumption
- Remote shutdown permits power sequencing to be easily implemented
- Hermetic 8-Lead Flat Pack ensures higher reliability
- Space Level Screened
- This part is also available in MO-078 Package as IRUH50P333B1M

Absolute Maximum Ratings

Parameter	Symbol	Value	Units
Output Current	I _O	3.5	A
Input Voltage	V _{IN}	7.0	V
Power Dissipation, T _C = 25°C	P _{TOT}	19	W
Thermal Resistance, Junction to Case	R _{THJC}	6.5	°C/W
Operating Temperature Range	T _J	-55 to +125	°C
Storage Temperature Range	T _S	-65 to +150	
Lead Temperature	T _L	300	

Pre-Radiation

Electrical Characteristics @T_C = 25°C (Unless Otherwise Specified)

Parameter	Test Conditions	Symbol	Min.	Typ.	Max.	Units
Output Voltage	V _{IN} = 5.0V, I _O = 1.5A	V _{OUT}	3.267	3.3	3.333	V
	V _{IN} = 4.5V, I _O = 50mA		3.135	-	3.465	
	V _{IN} = 4.5V, I _O = 3.0A		3.135	-	3.465	
	V _{IN} = 5.5V, I _O = 50mA		3.135	-	3.465	
	V _{IN} = 5.5V, I _O = 3.0A		3.135	-	3.465	
Input Voltage Range - Operating	I _O = 3.0A	V _{IN}	4.5	-	6.5	
Dropout Voltage	I _O = 3.0A, V _{OUT} = 3.3V	V _{DROP}	-	-	0.4	
Current Limit	V _{IN} = 5.0V, Overcurrent Latchup	I _{LATCH}	3.0	-	-	A
Ripple Rejection	F = 120Hz, I _O = 50mA		65	-	-	dB
Shutdown Source Current	V _{SHDN} = 5.0V	I _{SHDN}	-	200	-	μA
Shutdown Pin Threshold ①	V _{IN} = 5.0V	V _{SHDN}	1.0	-	1.6	V
Output Voltage at Shutdown	V _{IN} = 5.0V, I _O = 50mA, V _{SHDN} = +5.0V	V _{OUT} (SHDN)	-0.1	-	+0.1	

Pre-Radiation

Electrical Characteristics @T_C = -55°C to 125°C (Unless Otherwise Specified)

Parameter	Test Conditions	Symbol	Min.	Typ.	Max.	Units
Output Voltage	V _{IN} = 5.0V, I _O = 1.5A	V _{OUT}	3.135	3.3	3.465	V
	V _{IN} = 4.5V, I _O = 50mA		3.135	-	3.465	
	V _{IN} = 4.5V, I _O = 3.0A		3.135	-	3.465	
	V _{IN} = 5.5V, I _O = 50mA		3.135	-	3.465	
	V _{IN} = 5.5V, I _O = 3.0A		3.135	-	3.465	
Input Voltage Range - Operating	I _O = 3.0A	V _{IN}	4.5	-	6.5	
Dropout Voltage	I _O = 3.0A, V _{OUT} = 3.3V	V _{DROP}	-	-	0.4	
Current Limit	V _{IN} = 5.0V, Overcurrent Latchup	I _{LATCH}	3.0	-	-	A
Ripple Rejection	F = 120Hz, I _O = 50mA		65	-	-	dB
Shutdown Source Current	V _{SHDN} = 5.0V	I _{SHDN}	-	200	-	μA
Shutdown Pin Threshold ①	V _{IN} = 5.0V	V _{SHDN}	1.0	-	1.6	V
Output Voltage at Shutdown	V _{IN} = 5.0V, I _O = 50mA, V _{SHDN} = +5.0V	V _{OUT} (SHDN)	-0.1	-	+0.1	

For notes, please refer to page 3

Post-Radiation

Electrical Characteristics @T_C = 25°C (Unless Otherwise Specified)

Parameter	Test Conditions	Symbol	Min.	Typ.	Max.	Units
Output Voltage	V _{IN} = 5.0V, I _O = 1.5A	V _{OUT}	3.135	-	3.465	V
	V _{IN} = 4.5V, I _O = 50mA		3.135	-	3.465	
	V _{IN} = 4.5V, I _O = 3.0A		3.135	-	3.465	
	V _{IN} = 5.5V, I _O = 50mA		3.135	-	3.465	
	V _{IN} = 5.5V, I _O = 3.0A		3.135	-	3.465	
Current Limit	V _{IN} = 5.0V	I _{MAX}	3.0	-	-	A
Ripple Rejection	F = 120Hz, I _O = 50mA		40	-	-	dB
Output Voltage at Shutdown	V _{IN} = 5.0V, I _O = 50mA, V _{SHDN} = +5.0V	V _{OUT (SHDN)}	-0.1	-	+0.1	V

Notes for Electrical Characteristic Tables

① V_{Shutdown} ramp from 0.8V to 4.8V, output monitored for a 100mV drop below the nominal specification for V_{out}

Pre-Radiation Characteristics

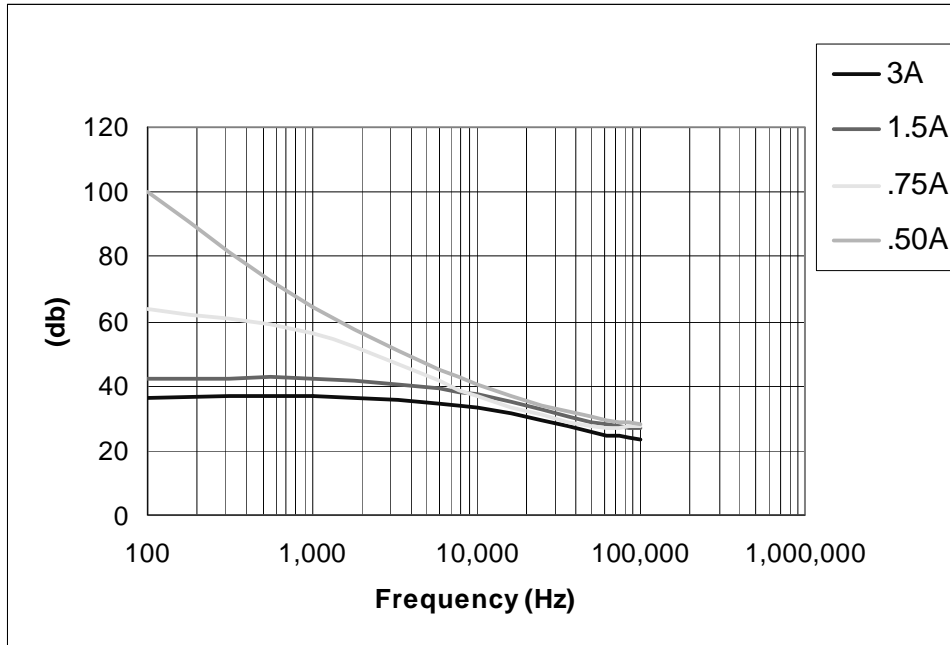

Fig 1. Ripple Rejection Vs Frequency

Radiation Performance Characteristics

Test	Conditions	Min	Typ	Unit
Total Ionizing Dose (Gamma)	MIL-STD-883, Method 1019 Operating Bias applied during exposure Full Rated Load, Vin=5.0V	1,000		Krads (Si)
Neutron Fluence	MIL-STD-883, Method 1017	1.00E+09	1.00E+13	Neutrons/cm ²
Single Event effects SEU, SEL, SEGR, SEB	Heavy Ions (LET) Operating Bias applied during exposure Full Rated Load, Vin=5.0V	84		MeV*cm ² /mg

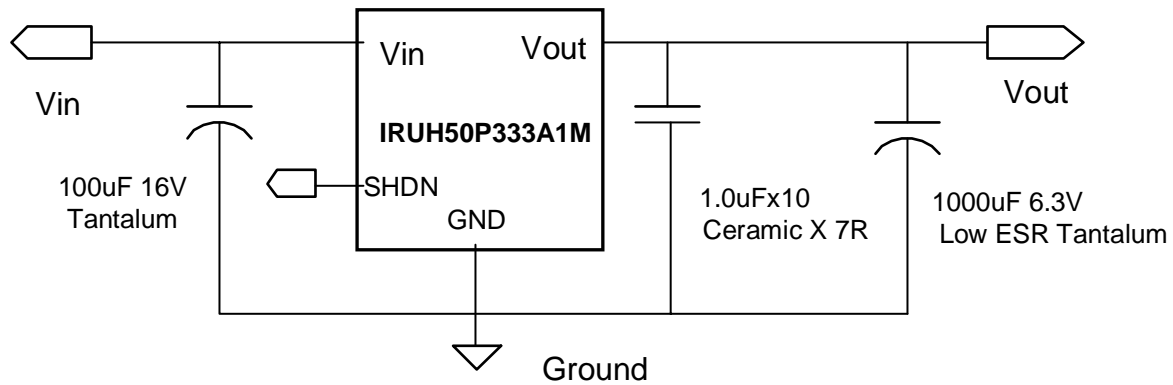

Fig 2. Typical Application Circuit

Input Capacitance

Recommended input capacitance for a generic application is a 100µF, 16V tantalum capacitor. However, the input capacitance is not critical to the stability of the regulator and is therefore application dependant. In designs with a clean bus voltage that is situated close to the input of the regulator, only a small ceramic capacitor will be needed to decouple high frequency noise. On the other hand, in designs with a noisy bus, a larger capacitor will be needed. Care should be taken to ensure that the input to the regulator is sufficiently free of noise and disturbances.

Output Capacitance

Like most ultra low dropout voltage regulators, IRUH50P333A1M requires the use of output capacitors as part of the device frequency compensation. The device requires a minimum of 220µF tantalum to ensure stability.

Many different types of capacitor are available and have widely varying characteristics. These capacitors differ in capacitor tolerance, equivalent series resistance (ESR), equivalent series inductance and capacitance temperature coefficient. The IRUH50P333A1M frequency compensation optimizes frequency response with low ESR capacitors. In general, use capacitors with an ESR of less than 50mΩ for heavy load applications.

High quality bypass capacitors must be also be used to limit the high frequency noise generated by the load. Multiple small ceramic capacitors are typically required to limit parasitic inductance (ESL) and ESR in the capacitors to acceptable levels.

The upper limit of the capacitance is governed by the delayed over-current latch function of the regulator. The regulator has a protection circuit that will latch the device off in the event of a short circuit. However, since it is known that the regulator will draw a large in-rush current upon startup, the latch-off is delayed by about 10ms to allow the output capacitors to charge to a steady state without shutting down. During this period, the regulator will have an output current at its maximum of around 5A typical. Therefore, the maximum output capacitance can be as high as 20,000µF without causing device to latch-off during start-up.

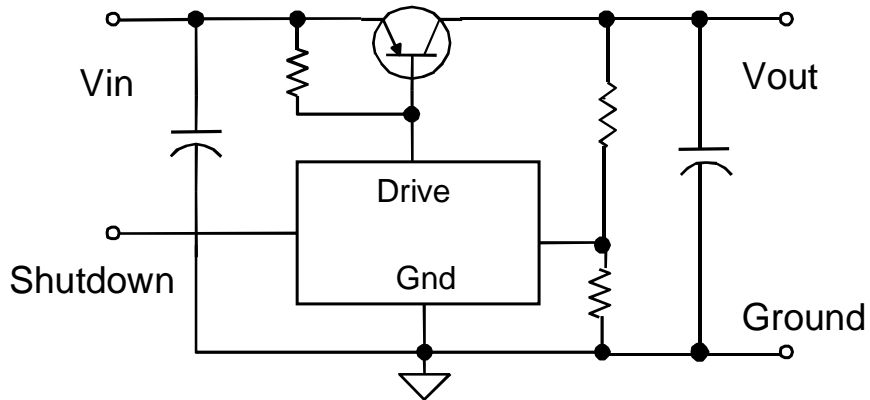

Fig 3. Simplified Schematic Circuit

Space Level Screening Requirements

TEST/INSPECTION	SCREENING LEVEL	MIL-STD-883
	SPACE	METHOD
Pre Seal Burn-In	Optional	1030
Nondestructive Bond Pull	100%	2023
Internal Visual	100%	2017
Temperature Cycle	100%	1010
Constant Acceleration	100%	2001
Mechanical Shock	100%	2002
PIND	100%	2020
Pre Burn-In-Electrical	100%	
Burn-In	100%	1015
Final Electrical	100%	
Seal	100%	1014
Radiographic	100%	2012
External Visual	100%	2009

Note:

International Rectifier does not currently have a DSCC certified Radiation Hardness Assurance Program

Case Outline and Dimensions - 8-Lead Flat Pack

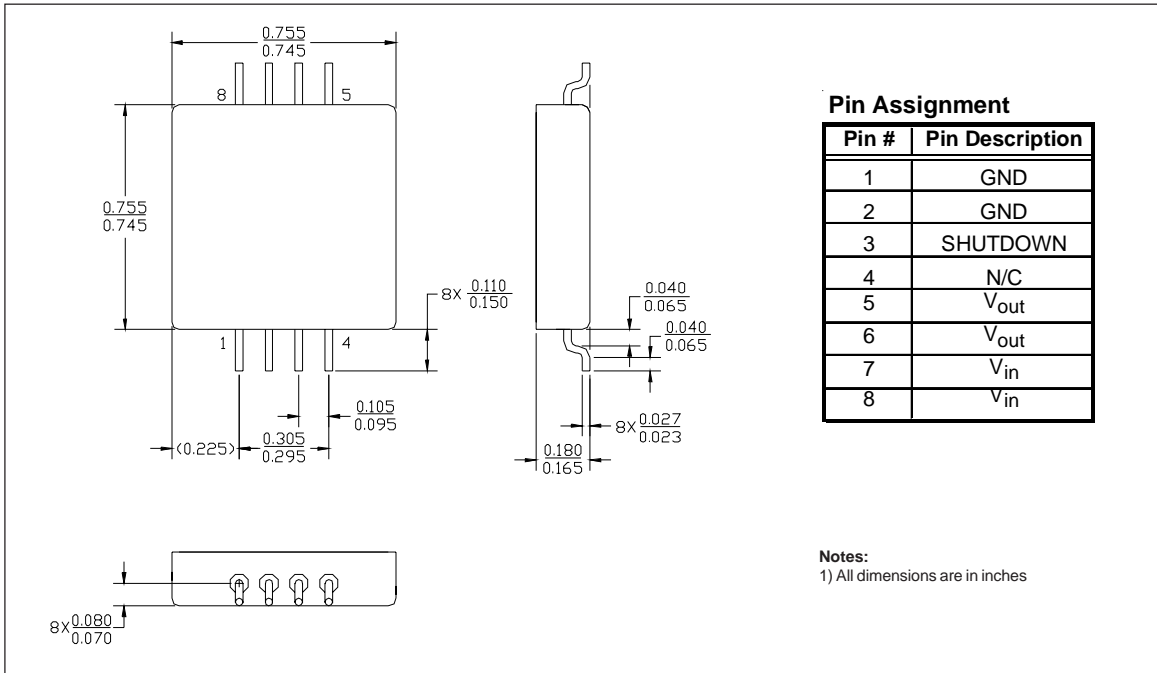

Part Numbering Nomenclature

