



Portable Solutions

Comprehensive power management, protection and media solutions for today's variety of portable applications from ON Semiconductor.



Low Profile, Small Footprint Packaging

ON Semiconductor offers the latest in low-profile, small-outline packaging. We enable the design and production of ultra-thin end-user products for the consumer market, by manufacturing some of the lowest profile packaging available in the world, in vast volumes. Whether you are designing mobile phones, MP3 players, digital still cameras, PDAs, game players, or other portable appliances, our packaging technology allows the ON Semiconductor product portfolio to be used in designs with the most demanding space constraints.



All of our packages are available with Pb-free leads to ensure compliance with RoHS standards.

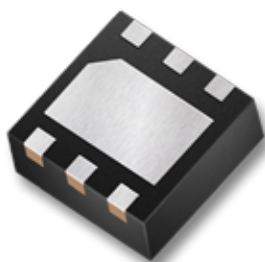
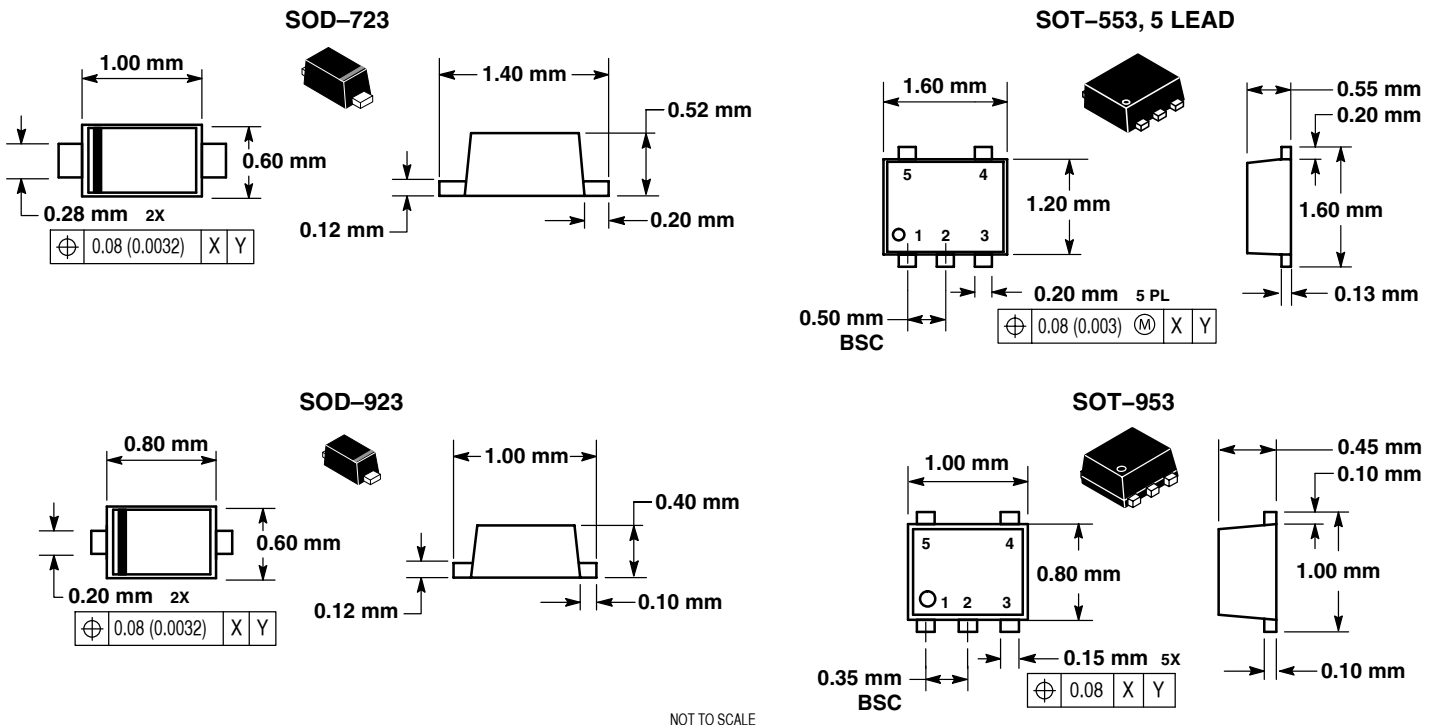

DFN-6, 3x3



ChipFET™



SOT-23-5

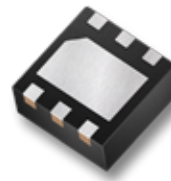

WDFN-6, 2x2



SC-70



SOT-723

Realistic sizes are approximate.

A Multitude of Solutions for Today's Portable Electronics



High Efficiency DC-DC Converters

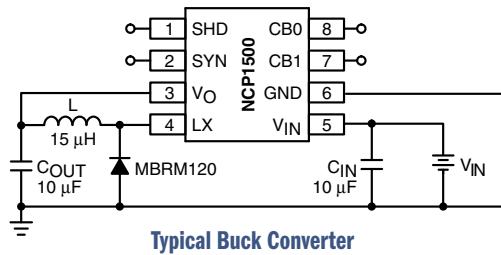

Typical Buck Converter

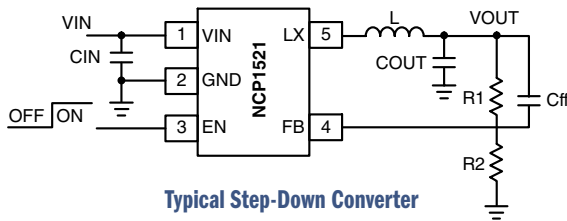

Typical Step-Down Converter

Key Features

- PWM buck converter operates either as an LDO or in PFM mode when output current decreases (NCP1500/01/19/21/22/23/29), maximizing efficiency at both light and full loads
- High switching frequencies allow use of smaller output filters, capacitors, and inductors, while maintaining high efficiency

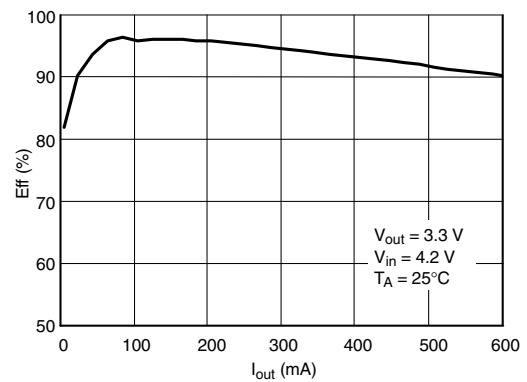

NCP1521 - Efficiency vs Output Current

Buck Converters

Device	Package(s)	Topology	Frequency	Input Voltage	Output Voltage	Max Current	Typical Efficiency	Features
NCP1500	Micro8™	PWM/Linear	External Sync 270-630 kHz	2.7 - 5.4 V	1.0 - 1.8 V Selectable	300 mA	91%	Turns into LDO Mode when Sync is Absent
NCP1501	Micro8	PWM/Linear	External Sync 450-1000 kHz	2.5 - 5.2 V	1.0 - 1.8 V Selectable	300 mA	92%	Sync Rec, Turns into LDO Mode when Sync is Absent
NCP1510A	MicroBump-9	PWM/Pulse	1 MHz or External Sync 450-1000 kHz	2.7 - 5.2 V	1.0 - 1.8 V Selectable	300 mA	95%	Sync Rec, Turns into Pulse Mode to Save Power when Sync Pin is Low
NCP1519*	Thin SOT-23-5	PWM/PFM	1.7 Mhz	2.7 - 5.5 V	Adj 0.9 - 3.3 V by External Resistors, 1.2, 1.5, 1.8 V	400 mA	96%	Sync Rec, Ultra-Low 60 μA Iq at Light Loads
NCP1521	Thin SOT-23-5, Thin DFN-6	PWM/PFM	1.5 Mhz	2.7 - 5.5 V	Adjustable 0.9 - 3.3 V by External Resistors	600 mA	96%	Sync Rec, Ultra-Low 30 μA Iq at Light Loads
NCP1522	Thin SOT-23-5	PWM/PFM	3 MHz	2.7 - 5.5 V	Adjustable 0.9 - 3.3 V by External Resistors	600 mA	93%	Sync Rec, Ultra-Low 60 μA Iq at Light Loads
NCP1523*	MicroBump-8	PWM/PFM	3 MHz	2.7 - 5.5 V	Adjustable 0.9 - 3.3 V by External Resistors	600 mA	93%	Sync Rec, Ultra-Low 60 μA Iq at Light Loads
NCP1526	Thin DFN-10	Dual Output PWM + LDO	3 MHz	2.7 - 5.5 V	PWM 1.2 V; LDO 2.8 V Other Options Available	PWM 400 mA LDO 150 mA	95%	Sync Rec, Ultra-Thin DFN: 0.55 mm Thickness
NCP1529*	Thin SOT-23-5	PWM/PFM	1.7 Mhz	2.7 - 5.5 V	Adj 0.9 - 3.3 V by External Resistors, 1.2, 1.5, 1.8 V	1 A	96%	Sync Rec, Ultra-Low 60 μA Iq at Light Loads
NCP1530	Micro8	PWM/PFM	600 kHz or External Sync Up to 1200 kHz	2.7 - 5.5 V	2.5 - 5.0 V	600 mA	92%	Programmable Soft-Start
NCP1550	SOT-23-5	PWM/PFM	600 kHz	2.5 - 6.0 V	1.8 - 3.3 V	2000 mA (Ext Switch)	90%	Enable Pin

* Planned 2H06

High Efficiency DC-DC Converters

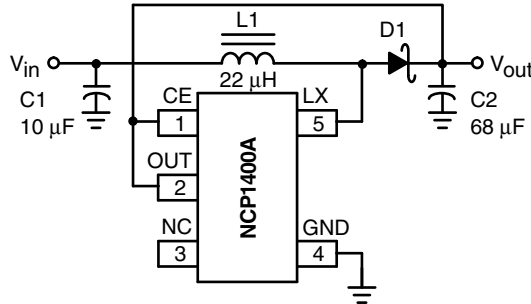

Typical Boost Converter

Key Features

- High switching frequency allows use of small inductors and capacitors

Feature	NCP1410	Competitor
Output Voltage Range	1.5 ~ 5.5 V	2.0 ~ 5.5 V
Operation Startup Voltage	1.0 ~ 5.5 V	1.1 ~ 5.5 V
Max Switching Frequency	600 kHz	500 kHz
Inductor	15 to 22 μH	22 μH
Output Ripple Voltage	34 mA Typ	Not Specified
Efficiency	92% Typ	91% Typ
Operating Current @ I _{OUT} = 0	9 μA Typ	16 μA Typ
Shutdown Current	0.05 μA Typ	0.1 μA Typ
Reference Voltage Accuracy	1.19 V ± 0.6%	1.3 V ± 2.0%

Boost Converters

Device	Package(s)	Topology	Frequency	Input Voltage	Output Voltage	Max Current	Typ Efficiency	Features
NCP1400A	SOT-23-5	PWM	180 kHz	0.8 - 5.5 V	1.8 - 5.0 V	100 mA	88%	Enable Pin
NCP1402	SOT-23-5	PFM	180 kHz	0.8 - 5.5 V	1.8 - 5.0 V	200 mA	85%	Enable Pin
NCP1403	SOT-23-6	PFM	300 kHz	1.2 - 5.5 V	Up to 15 V	50 mA	82%	Enable Pin
NCP1406	SOT-23-5	PFM	1000 kHz	1.2 - 5.5 V	Up to 25 V	50 mA	85%	Enable Pin
NCP1410	Micro8™	PFM	600 kHz	1.0 - 5.5 V	1.5 - 5.5 V	250 mA	92%	Sync Rec, Low Battery Detection
NCP1421	Micro8	PFM	1200 kHz	1.0 - 5.0 V	1.5 - 5.0 V	600 mA	94%	True Cutoff, Ring-Killer, Low Battery Detection
NCP1422	DFN-10	PFM	1.2 MHz	1.0 - 5.0 V	1.0 - 5.0 V	800 mA	94%	Sync Rec, True Cutoff, Low Battery Detection
NCP1423	Micro10	PFM	600 kHz	0.8 - 3.3 V	1.8 - 3.3 V	400 mA	92%	Sync Rec, True Cutoff, Low Battery Detection, Low Startup Voltage (0.8 V)
NCP1450A	SOT-23-5	PWM	180 kHz	0.8 - 5.5 V	1.8 - 5.0 V	1000 mA (Ext Switch)	88%	Enable Pin

Optimize Figure-of-Merit with MOSFETs for DC-DC Conversion

Complete μCool™ Portfolio

- N-Channel & P-Channel
- Single, Dual, Complementary and FETKY®
- 8 V, 20 V, 30 V

Key Performance Characteristics

- Low R_{ds(on)} and Gate Charge Deliver Low Figure-of-Merit Ratio (<110 for Single N-Channel)
- Package Thermal Resistance of 38°C/W
- Package Footprints as Small as 4 mm²
- Low Profile <0.75 mm

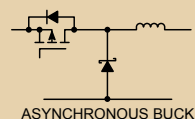
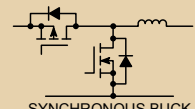
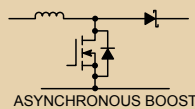
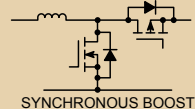

μCool™ MOSFETs

Device	V _{DS}	Polarity	Configuration	R _{DS(ON)} *	Package
NTJD4116N	30 V	N	Dual	<70 mΩ	WDFN, 2 x 2 mm
NTLJF4156N	30 V	N	FETKY	<70 mΩ	WDFN, 2 x 2 mm
NTLJF3117P	20 V	P	FETKY	<100 mΩ	WDFN, 2 x 2 mm
NTLJD3119C	20 V	N/P	Complementary	<70/100 mΩ	WDFN, 2 x 2 mm

Other New MOSFETs

Device	V _{DS}	Polarity	Configuration	R _{DS(ON)} *	Package
NTHD3102C	20 V	N/P	Complementary	<45/85 mΩ	ChipFET™, 2 x 3 mm
NTGS3441P	20 V	P	Single	<110 mΩ	TSOP-6, 3 x 3 mm
NTGD3122C	20 V	N/P	Complementary	<80/145 mΩ	TSOP-6, 3 x 3 mm
NTGF3123F	20 V	P	FETKY	<80 mΩ	TSOP-6, 3 x 3 mm
NTJS4160N	30 V	N	Single	<85 mΩ	SC-88, 2 x 2 mm

* R_{DS(ON)} 4.5 V_{GS}

Smaller, Thinner, Faster, Cooler & Safer Load Switch Elements

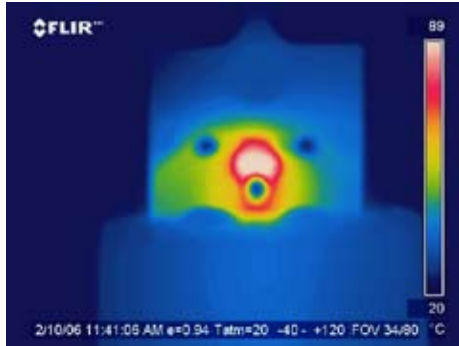

Thermal Image of μ Cool™ NTLJS3113P (Power FET)

Minimum Pad, $I_{(load)} = 4$ A, Steady State

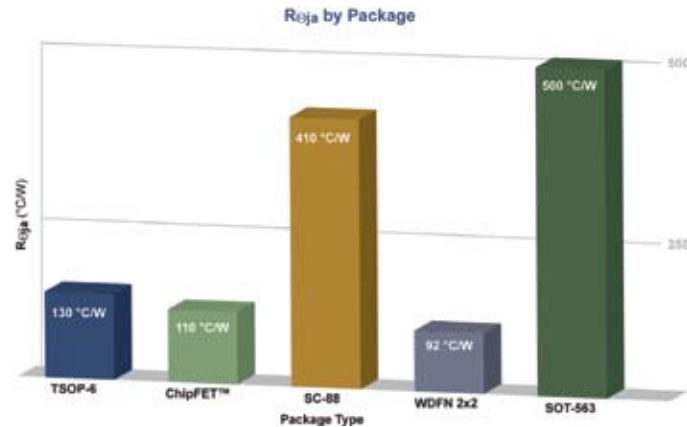

Thermal Resistance Comparison of Different Packages

Test Conditions: FR4, 1-in-2, 1 oz Cu, Dual Die

Power MOSFETs							
	Device	BVDSS	Polarity	Configuration	RDS(ON) 4.5 Vgs	Package	Dimensions
High Load Current >4 A	NTLTS3107P	20 V	P	Single	< 16 mΩ	Micro-8 LL	3.3 x 3.3 mm
	NTHS5404	20 V	N	Single	< 30 mΩ	ChipFET	3 x 2 mm
	NTLJS4159N	30 V	N	Single	< 35 mΩ	WDFN	2 x 2 mm
Low to Medium Load Current <4 A	NTLJD4114N	30 V	N	Dual	< 70 mΩ	WDFN	3.3 x 3.3 mm
	NTZD3151P	20 V	P	Single	< 150 mΩ	SOT-563	1.6 x 1.6 mm
	NTK3142P	20 V	P	Single	< 4 Ω	SOT-723	1.2 x 1.2 mm
Integrated Load Switches							
	Device	Description				Package	Dimensions
Integrated Load Switches	NTGD1100L	N-Channel Level Shift, 8 V P-Channel Switch < 80 mΩ				TSOP-6	3 x 3 mm
	NTJD1155L	N-Channel Level Shift, 8 V P-Channel Switch < 175 mΩ				SC-88	2 x 2 mm
	NTLJD2105L	N-Channel Level Shift, 8 V P-Channel Switch < 50 mΩ				WDFN	2 x 2 mm
Low V _{CE(sat)} BJTs							
	Device	Description				Package	Dimensions
Low to Medium Load Current <4 A	NSS35200CF8T1G	35 V, 2 A DC, 7 A Peak				ChipFET	2 x 3 mm
	NSS40400CF8T1G	40 V, 4 A DC, 7 A Peak				ChipFET	2 x 3 mm
	NSS30201MR6T1G	30 V, NPN, 2 A DC, 3 A Peak				TSOP-6	2 x 3 mm
High Load Current >4 A	NSS40600CF8T1G	40 V, PNP, 6 A DC, 7 A Peak				ChipFET	2 x 3 mm
	NSS40601CF8T1G	40 V, NPN, 6 A DC, 7 A Peak				ChipFET	2 x 3 mm
	NSS12500UW3T2G	12 V, PNP, 5 A DC, 7 A Peak				WDFN-3	2 x 2 mm
Integrated Load Switches							
	Device	Description				Package	Dimensions
Integrated Load Switches	EMF5XV6T5	12 V, PNP with NPN BRT Driver				SOT-563	1.6 x 1.6 mm

Smaller, Thinner, Faster, Cooler & Safer Charging Switch Elements

Charging Switches			
Device Type	Package		
	WDFN 2x2 mm	SOT-23/TSOP-6	ChipFET
FET Single	NTLJS3113P	NTGS3443P	NTHS4101P, NTHS5441
Low $V_{CE(sat)}$ BJT	NSS12500UW3T1G	NSS30100LT1G	NSS35200CF8T1G
FET + Schottky	NTLJF3117P	NTGF3123P	NTHD3101F, NTHD4P02F
FET Dual	NTLJD3115P	NTGD4161P	NTHD4102P, NTHD4401P

Key Features

- Thermal Performance >1.5 W
- Package Footprints as Small as 4 mm²
- Low Profile <0.8 mm

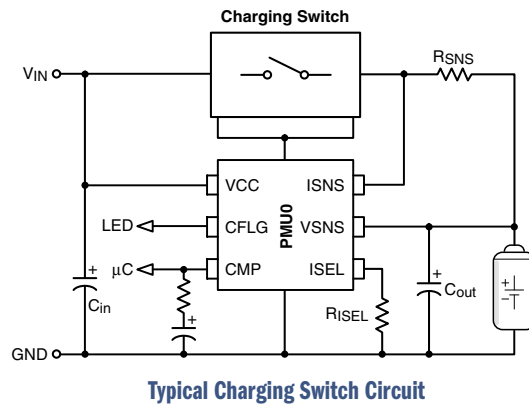
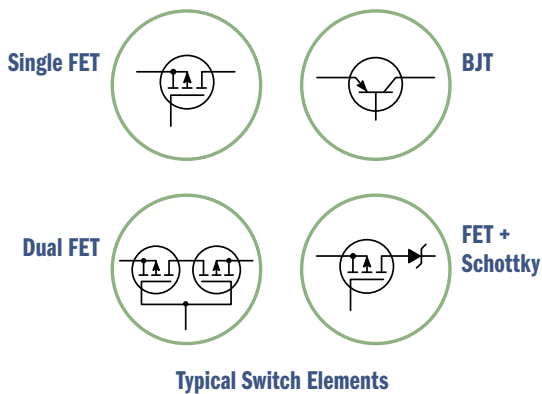

Rectifiers Manage Big Power in Small Packages

Schottky Rectifiers

Device	V_{RRM}	V_f	Current	Package
MBRM110E	10 V	0.46 V	1 A	POWERMITE®
MBRM120E	20 V	0.46 V	1 A	POWERMITE
MBRM130L	30 V	0.33 V	1 A	POWERMITE
MBRM140	40 V	0.52 V	1 A	POWERMITE
MBR0520L	20 V	0.33 V	0.5 A	SOD-123
MBR0530	30 V	0.43 V	0.5 A	SOD-123
MBR0540	40 V	0.46 V	0.5 A	SOD-123
MBR130	30 V	0.47 V	1 A	SOD-123

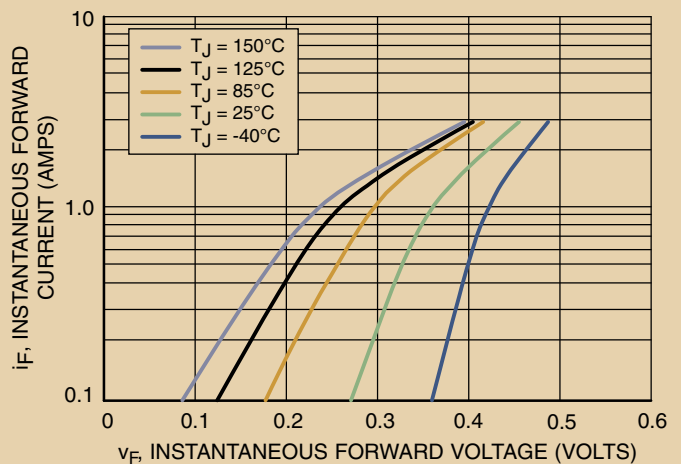

Low Standby Current Battery Management for Extended Battery Life

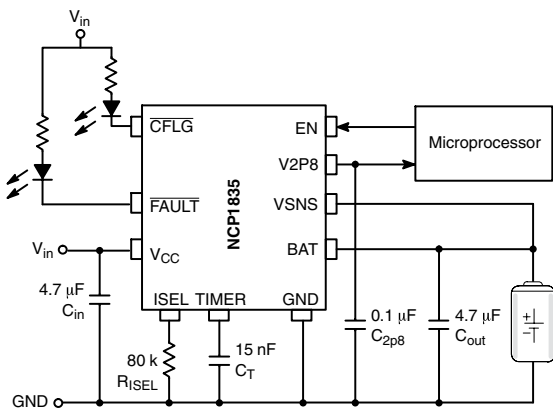

Typical Application Circuit

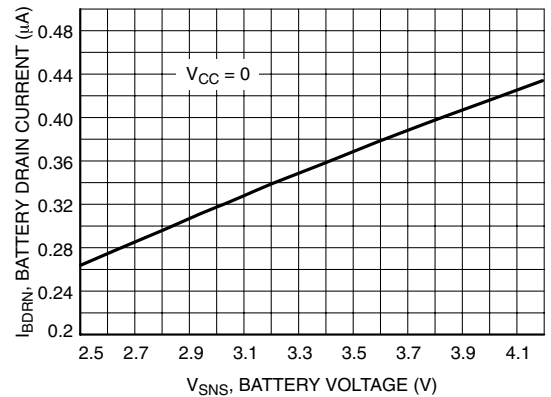

Battery Drain Current versus Battery Voltage

Battery Management Circuits

Device	Description	Package	Key Features
NCP1835	Up to 1 A Single-Cell Lithium-ion/Polymer Integrated CCCV Battery Charger	DFN-10	No External MOSFET
NCP1835B	Up to 300 mA Single-Cell Lithium-ion/Polymer Integrated CCCV Battery Charger	DFN-10	No External MOSFET
NCP1800	Single-Cell Lithium-ion CCCV Battery Charger	Micro8™	Industry Leading Standby Current 0.5 μA, Adjustable Charge Current Limit
MC33340/2	Nickel Chemistry Battery Cradle Charger	SOIC-8	Peak Voltage Detection

Integrated Overvoltage Protection for Battery and Charging Circuits

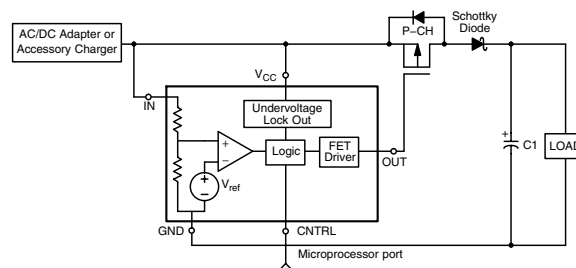

Typical OVP Device Diagram

Battery Protection Circuits

Device	Overvoltage Protection			MOSFET		Package			Ambient Operating Temperature (°C)
	UVLO (V)	OVP (V)	Logic Override	Vds (V)	Rdson max (mW) @ 4.5 V	Type	Area (mm)	Height (mm)	
NUS2045	2.8	6.85	Yes	20	71	DFN	3.3 x 3.3	0.85	-40 to +85
NUS3045	2.8	6.85	Yes	30	66	DFN	3.3 x 3.3	0.85	-40 to +85
NUS3046		5.5	Yes	30	66	DFN	3.3 x 3.3	0.85	-40 to +85
NUS1204		4.7	No	12	75	TDFN	2.0 x 2.0	0.85	-40 to +85
NUS3055	2.8	6.85	Yes	30	66	TLLGA	2.5 x 3.0	0.55	-40 to +85
NUS3035		4.45	Yes	30	66	TLLGA	2.5 x 3.0	0.55	-40 to +85
NCP345	2.6	6.85	Yes	NA	NA	SOT-23-5	3.0 x 2.75	1.00	-40 to +85
NCP346		4.4, 5.5	Yes	NA	NA	SOT-23-5	3.0 x 2.75	1.00	-40 to +85

Optimize Efficiency and Space with Inductive and Charge Pump LED Drivers

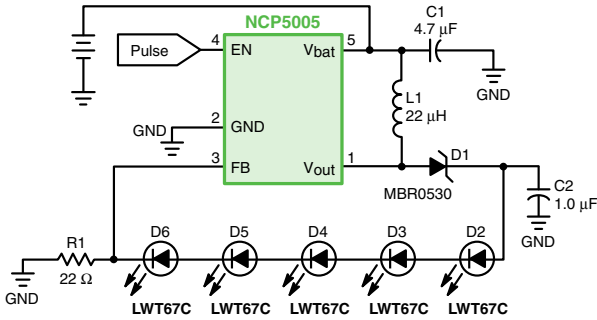

Inductive Solution – NCP5005

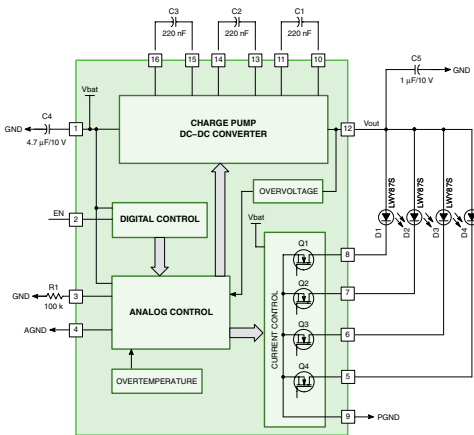

Charge Pump Solution – NCP5604A



Application	LED Type	Number of LEDs/ Connection	Topology	Product	Key Feature
Display Backlighting	Standard, 10-25 mA	2 LEDs/Parallel	Linear	NUD4301 : Adjustable (1-30 mA) constant current driver; DFN-8 (2 x 2 mm)	Linear or PWM dimming
		2 - 5 LEDs/Series	Inductive	NCP5006/5007 : Up to 92% efficiency PFM boost, 21 V/ 1 W output; thin SOT-23-5 (3 x 3 mm)	Simple, open LED output clamp
		3 - 5 LEDs/Series	Inductive	NCP5005 : Enhanced version of NCP5006 - high EMI immunity	Enhanced EMI immunity, best for RF sensitive application
		2 - 5 LEDs/Series	Inductive	NCP5010 : 1 MHz PWM boost, 22 V/0.5 W output, integrated rectifier & true-cutoff; uBump-8 (1.7 x 1.7 mm)	Highly integrated driver
		2 LEDs/Parallel	Charge Pump	NCP5602 : 90% peak efficiency, 2 outputs (25 mA each), 2% current matching; I2C; LLGA-12 (2 x 2 mm)	ICON mode; I2C dimming control
		2 LEDs/Parallel	Charge Pump	NCP5612 : 2 outputs (25 mA each), I2C; LLGA-12 (2 x 2 mm)	ICON mode; S-Wire link dimming control
		2 - 6 LEDs/Series	Inductive	NCP1406 : Up to 90% efficiency, PFM (up to 1 MHz), 25 V/0.5 W output; thin SOT-23-5 (3 x 3 mm)	Can operate from 1 or 2 alkaline or Ni-based cells
		3 or 4 LEDs/Parallel	Charge Pump	NCP5604A/B : Consistent 90% efficiency, 3 or 4 outputs (25 mA each), 0.5% current matching; TQFN-16 (3 x 3 x 0.8 mm)	NCP5604A: Drives 4 LEDs NCP5604B: Drives 3 LEDs
Flash (Torch)	Low current - up to 50 mA for 1 cell/100 mA for 2 cell	Single LED	Inductive	NCP1400ASN50 : Fixed frequency PWM micropower boost converter; thin SOT-23-5 (3 x 3 mm)	Can operate from 1 or 2 alkaline or Ni-based cells
	Medium current/Multi-die WLED, 100-350 mA	Single (or multiple in parallel)	Charge Pump	NCP5603 : 200 mA cont/350 mA pulsed, voltage regulated output, 4.5 V or 5 V, 75% eff; DFN-10 (3 x 3 mm)	High-current single output charge pump
	Medium current up to 50 mA for 2 cell and 100 mA for 3 cell	2 - 6 LEDs/Series	Inductive	NCP1406 : Up to 90% efficiency, PFM (up to 1 MHz), 25 V/0.5 W output; thin SOT-23-5 (3 x 3 mm)	Simple, low cost
	High current WLED, up to 600 mA	Single (or multiple in parallel)	Inductive	NCP1421 : PFM boost (up to 1.2 MHz), sync rec, output up to 5 V, 600 mA cont, 94% eff, true-cutoff, 50 nA shutdown current; Micro8 (3 x 5 mm)	Synchronous rectification
	High current WLED, up to 800 mA	Single (or multiple in parallel)	Inductive	NCP1422 : PFM boost (up to 1.2 MHz), sync rec, output up to 5 V, 800 mA cont, 94% eff, true-cutoff, 50 nA shutdown current; DFN-10 (3 x 3 mm)	Synchronous rectification
	High current WLED, up to 1 A	2 - 5 LEDs/Series	Inductive	NCP5050 : 23 V/4.5 W output, PWM, 1.7 MHz; DFN-10	Integrated switch for 2 adjustable output current levels
Single Driver for Backlight & Flash	LED (10 - 25 mA), Flash LED (100 - 400 mA)	4 LEDs + Flash LED	Charge Pump	NCP5608 : Consistent 90% efficiency, 8 outputs (4 @ 25 mA each + 4 @ 100 mA each), 0.5% current matching; TQFN-24 (4 x 4 mm)	One chip lighting solution
OLED Driver Supply	—	—	Inductive	NCP1406 : Up to 90% efficiency, PFM (up to 1 MHz), 25 V/0.5 W output; thin SOT-23-5 (3 x 3 mm)	Can operate from 1 or 2 alkaline or Ni-based cells

BOLD denotes new or pending device.

EMI Filtering with ESD Protection for LCD and Camera Interfaces

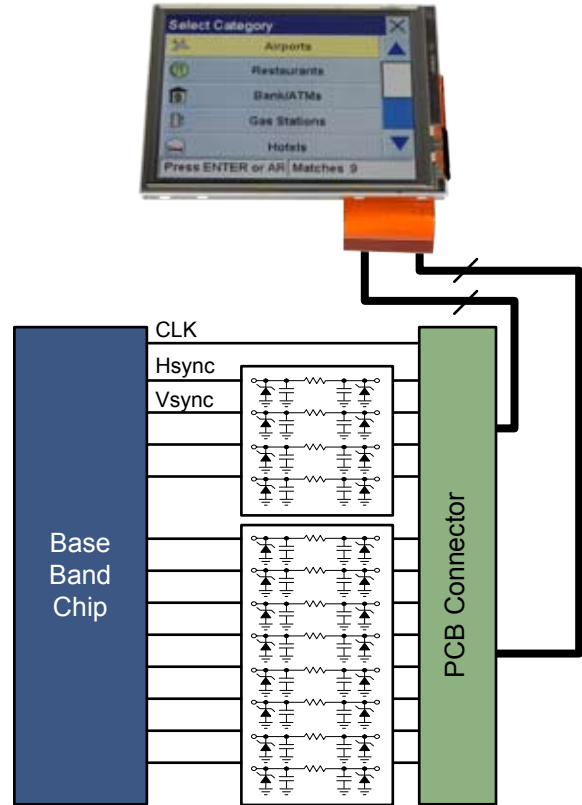
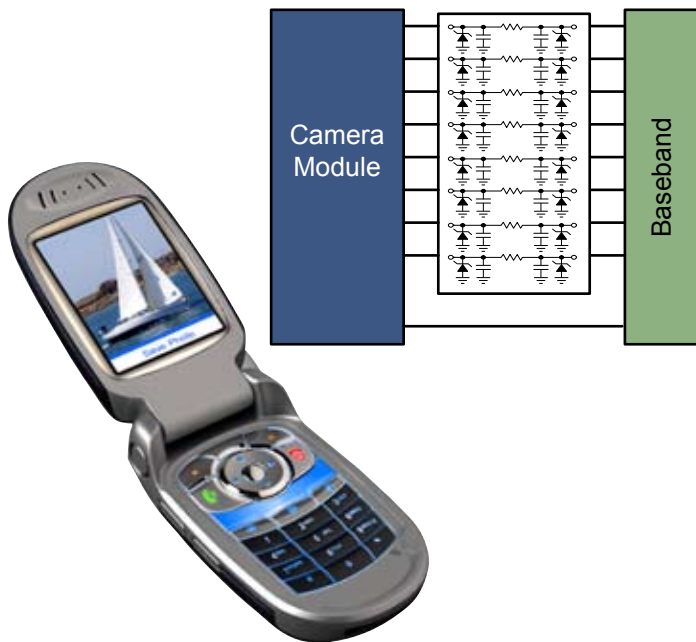

Key Features

- Excellent low-pass filter characteristics from 800 MHz to 5 GHz
- Low profile package for slim portable electronics
- 0.4 mm pin pitch provides improved layout options

EMI Filtering Devices					
Device	# Lines	Package	Capacitance (pF) @ 2.5 V/Diode	Attenuation @ 900 mHz to 5.0 Ghz	Comments
NUF4402MN	4	DFN 8	12	> -28 dB	Low parasitic inductance package design
NUF4403MN	4	DFN 8	17	> -35 dB	
NUF4210MN	4	DFN 8	8.5	> -19 dB	
NUF4001MU	4	uDFN 8*	12	> -30 dB	
NUF6401MN	6	DFN 12	17	> -35dB	Low parasitic inductance package design
NUF6406MN	6	DFN 12	13	> -28dB	
NUF6402MN	4 + 4	DFN 12	17	> -35dB	
NUF6001MU	6	uDFN 12*	17	> -35dB	
NUF8401MN	8	DFN 16	13	> -28 dB	-
NUF8402MN	8	DFN 16	17	> -35 dB	
NUF8410MN	8	DFN 16	8.5	> -19 dB	
NUF8001MU	8	uDFN 16*	13	> -28 dB	
NZF220D	2	SC-88	6	> -20 dB	-
NUF2030XV6	2	SOT-563	16	> -20 dB	
NUF2042XV6	2	SOT-563	21	> -20 dB	
NUF2220XV6	2	SOT-563	7	> -18 dB	
NUF2230XV6	2	SOT-563	16	> -23 dB	
NZF220T	1	SC-70	7	> -20 dB	

* Low profile package with 0.4 mm pin pitch

Transient Voltage Protection Devices for I/O

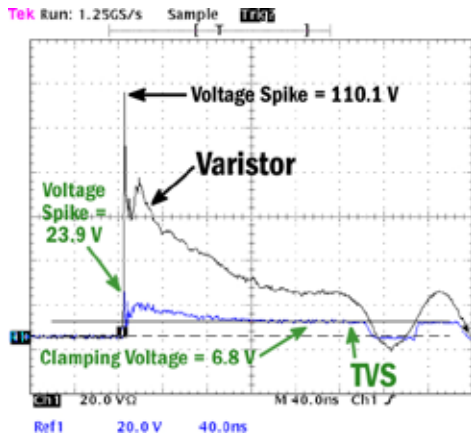

IEC61000-4-2 Contact Positive Pulse

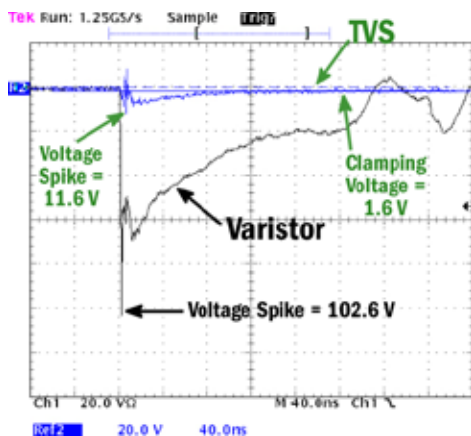

IEC61000-4-2 Contact Negative Pulse

Speaker/Microphone
ESD5B Series



USB Connector
NUP2202 Series
NUP4202 Series

Keypad/Volume Key
ESD9X Series μESDxxS Series
ESD5Z Series NUP45V6 Series
NZQA Series NUP5120 Series

Battery Contacts
ESD5Z Series

Bottom Connector
NZL Series μESDxxD Series
NZQA Series NUP5120 Series
NUP45V6 Series NUP8010 Series

Charger Line
ESD5Z Series

TVS Protection Devices

Device	Description	Package	Dimensions (mm) L x W x H	Surge Rating 8 x 20 μs	ESD Rating IEC61000-4-2 Contact
ESD9X Series	TVS and ESD Protection Diode	SOD-923	1.0 x 0.6 x 0.4	Up to 140 W	30 kV
μESDxxS Series	TVS and ESD Protection Diode	SOD-723	1.4 x 0.6 x 0.5	Up to 128 W	30 kV
μESDxxD Series	Dual TVS and ESD Protection Diode	SOT-723	1.2 x 1.2 x 0.5	—	22 kV
ESD5B Series	Bi-directional TVS and ESD Protection Diode	SOD-523	1.6 x 0.8 x 0.6	—	30 kV
ESD5Z Series	TVS and ESD Protection Diode	SOD-523	1.6 x 0.8 x 0.6	Up to 240 W	30 kV
NZL Series	Dual TVS and ESD Protection Diode	SC-89	1.6 x 1.6 x 0.7	—	22 kV
SM05 Series	Dual ESD Protection Diode	SOT-23	2.9 x 2.4 x 1.0	Up to 300 W	15 kV
NZQA Series	Quad TVS Array	SOT-553	1.6 x 1.6 x 0.55	Up to 100 W	9 kV
NUP45V6 Series	Quad TVS Array	SOT-953	1.0 x 1.0 x 0.45	—	8 kV
NUP5120 Series	Penta TVS Array	SOT-563	1.6 x 1.6 x 0.55	Up to 90 W	8 kV
NUP2202/4202 Series	Single and Dual Port USB 2.0	SC-88	2.0 x 2.1 x 1.0	Up to 500 W	20 kV
NUP8010 Series	Eight Line TVS Array	DFN-8	1.6 x 1.6 x 1.0	Up to 20 W	8 kV

Audio Filters – LC Network EMI Filters with ESD Protection

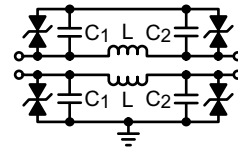
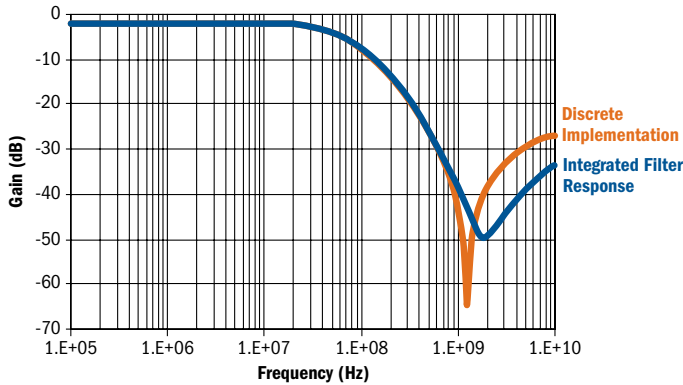

Figure 1

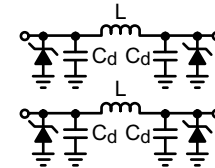

Figure 2

Key Features

- ESD protection exceeds 15 kV (IEC61000-4-2)
- Integrated Inductors ranges 2.7 - 5.0 nH
- Low Series Resistance of 0.28 - 4.0 Ohms
- Excellent S21 curves characteristics
- Steady state current of greater than 500 mA/line
- Peak Current 1.2 A

EMI Audio Filters

Device	Lines	Resistance (Ω)	Inductance (nH)	Package	Circuit Diagram
NUF2441FCT1G	2	0.27	3	Flip-Chip	Figure 1
NUF2450MUT1G	2	1.5	2.5	uDFN (1.2 x 1.8 mm)	Figure 2
NUF2070MNT1G	2	2.5	4.5	DFN (2.0 x 2.0 mm)	Figure 1
NUF2114MNT1G	2	10	–	DFN (2.0 x 2.0 mm)	–
NUF2116MNT1G	2	68	–	DFN (2.0 x 2.0 mm)	–
NUF4220MNT1G	4	1.2	5	DFN (2.0 x 2.0 mm)	Below

EMI Filter and ESD Protection for Stereo Headset Jacks Shrinks by 50% for MP3/Cellphone Applications

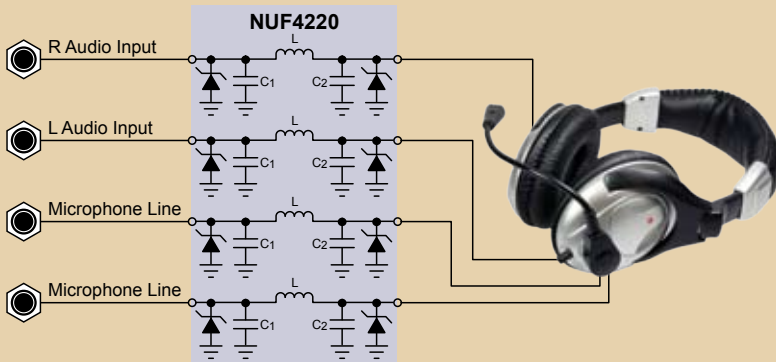

NUF4220 Stereo Headset Filter Solution

Key Performance Characteristics

- > 35 dB of RF Attenuation from 900-3000 MHz
- Compliant with IEC61000-4-2 (Level 4) - 15 kV Air and Contact
- Extremely low loss signal path in Audio Band
- 2 x 2 mm DFN Package
- Flow through pinout for easy PCB layout

NCP2820 Filter-Free Class D Audio Amp Improves System Efficiency and Eliminates PCB Hot Spots in Audio Subsystems

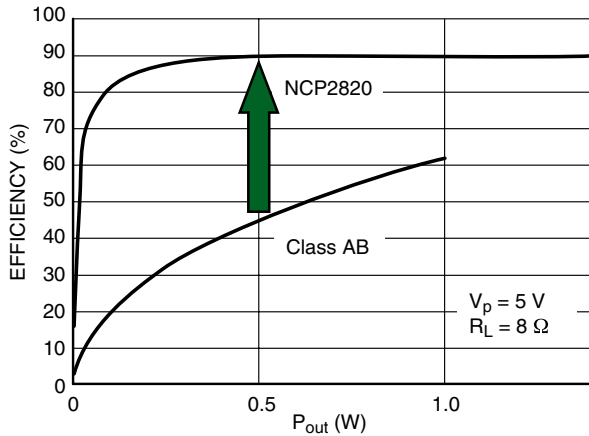

Extend Battery Life over with 2X Efficiency Improvement at 0.5 W Output Power

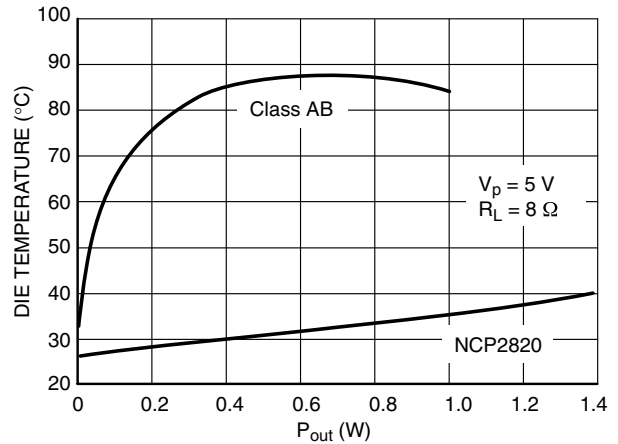

Keep Cool Across All Power Ranges

Key Performance Characteristics

- Wide Supply Range of 2.2 – 5.5 V
 - Superior >65 dB PSRR allows direct connection to the Battery
 - 1 W to 8 W (BTL) Bridge Tied Load or 2.65 W to 4 W BTL @ 5 V
- Thermal overload protection circuitry
- “Pop and click” noise protection circuit

Low Voltage Audio Amplifier Selector Guide

Audio Output/ Application	Class	Topology/ Features	Output Power	PSSR @ 217 Hz	Efficiency	THD+N	Turn-On Time (Typ)	Iq (Typ)	Shut-Down Current (Typ)	Package(s)	Device
Mono Speaker – Basic Telephone Operation & Polyphonic Ringtones	AB	BTL	1 W+	-73 dB	63%	0.02%	285 ms	1.5 mA	10 nA	Micro8™ Microbump-9	NCP2890
	AB	BTL	1 W+	-73 dB	63%	0.02%	100 ms	1.5 mA	10 nA	Microbump-9	NCP2892A
	AB	Differential	1 W+	-80 dB	64%	0.006%	140 ms	1.9 mA	20 nA	Microbump-9 DFN-10	NCP4894
Stereo Headphones – MP3 Players, Bluetooth Headsets	AB	Virtual Ground No Output Cap	135 mW/Ch	-82 dB	63%	0.003%	285 ms	1.54 mA	10 nA	Micro10	NCP2809
	AB	Differential	150 mW/Ch	-80 dB	64%	0.006%	140 ms	1.9 mA	20 nA	Microbump-9 DFN-10	NCP4894
Mono Speaker/Earpiece – Low Cost Integrated Solution	AB	Single End/ Differential	1 W to Speaker; 250 mW to Earpiece	-70 dB	64%	SE 0.003%, BTL 0.01%	140 ms	1.7 mA	20 nA	Microbump-9	NCP4896
Mono Speaker – Handsfree Speaker Phone	D	Filterless, Gain Select by Resistors	2.65 W	-65 dB	90%	0.05%	9 ms	2.2 mA	300 nA	Microbump-9 DFN-8	NCP2820
	D	Filterless, Integrated Ext Selectable Gain 6 or 12dB	2.65 W	-65 dB	90%	0.05%	9 ms	2.5 mA	500 nA	Microbump-9	NCP2821
Stereo Speakers – Offer Stereo Sound Quality to Play Video/Music-on-Demand, MP3	D	Filterless, Gain Selection by Resistor	2 W+ per Channel	-65 dB	90%	0.05%	9 ms	4.4 mA	600 nA	Microbump-9	2x NCP2820 or NCP2821

Complete Audio Amplifier Solution for Driving Speakerphone and Earpiece in a 2.1 mm² Chipscale Package

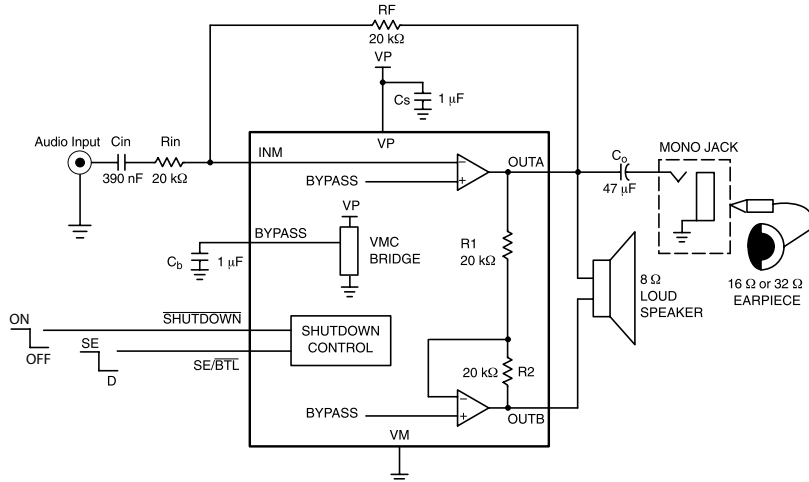

NCP4896 Class AB Audio Amplifier



Key Performance Characteristics

- Wide Supply Range of 2.2 – 5.5 V
- Superior >70 dB PSRR allows direct connection to the battery
- THD+N:
 - 0.003%-0.01% (40 mW Pout)
 - 0.02% (400 mW)
- 1 W to 8 W (BTL) Bridge Tied Load @ 5 V
- 90 mW to 32 W single ended load @ 5 V
- Thermal overload protection circuitry
- “Pop and click” noise protection circuit



NCP4896 Demo Board Available

Low Voltage, Low Power Comparators

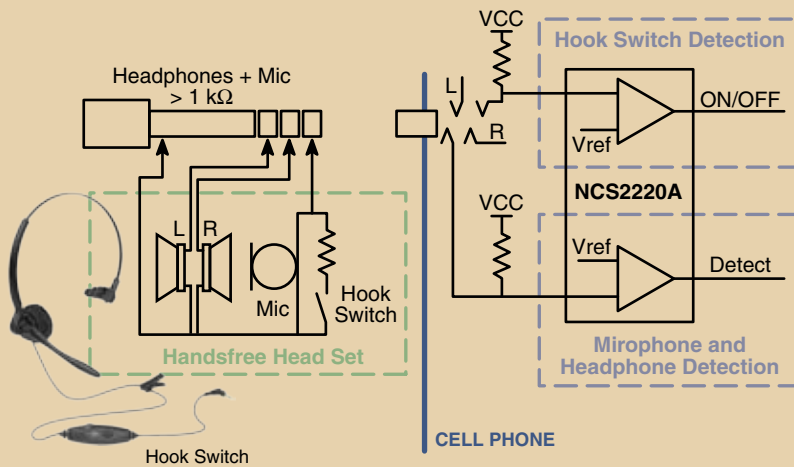

Typical Detection Circuit

Key Performance Characteristics

- Higher Detection Accuracy/Reliability
- Additional ESD Protection
- OK with DC and Audio Signals
- Internal Hysteresis
- Ultra Small Packaging

Comparators

Device	VRRM	Package(s)
NCS2200 Series	Single Low Voltage Comparator	SC-70, SOT-23, QFN 2 x 2.2, uDFN 1.2 x 1.0
NCS2200A	Dual Low Voltage Comparator	uDFN 1.6 x 1.6

Biased Audio for the Highest Output Power from a Single-Cell Lithium-Ion Battery

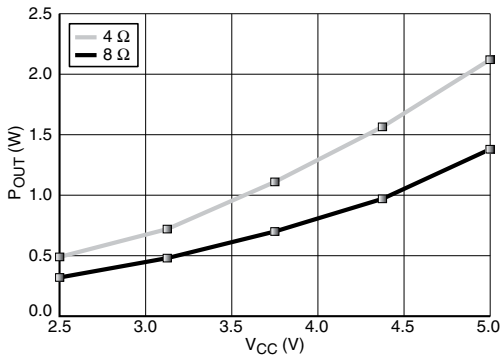

NCP2820 Output Power versus Supply for THD+N < 1%

To maximize the power output of a linear audio amplifier in portable applications, it is necessary to bias the amp at a fixed voltage instead of operating directly from the battery.

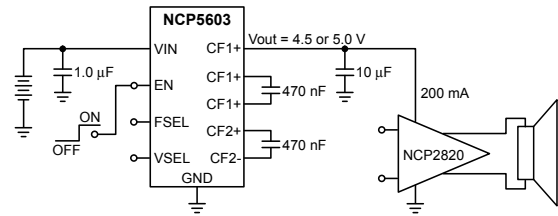

DC-DC Converters

Device	Architecture	Current Capability (V _{out} = 5 V, V _{in} = 3.6 V)	Efficiency @ Current Load (V _{out} = 5 V, V _{in} = 3.6 V)	Package
NCP5603	Charge Pump	160 mA	75%	DFN-10, 3 x 3 mm
NCP1421	Inductive	500 mA	87%	Micro10, 3 x 5 mm
NCP1422	Inductive	700 mA	88%	DFN-10, 3 x 3 mm

Stereo Switching with SPDT Audio Switches

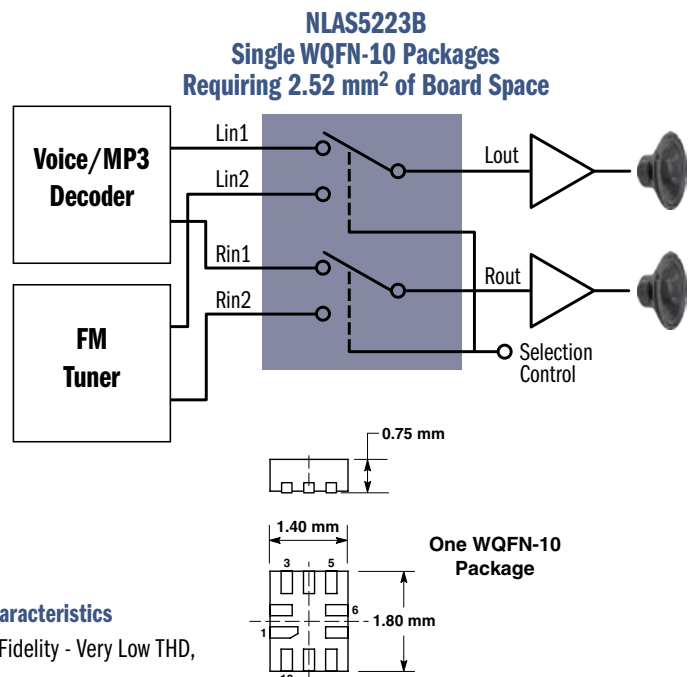
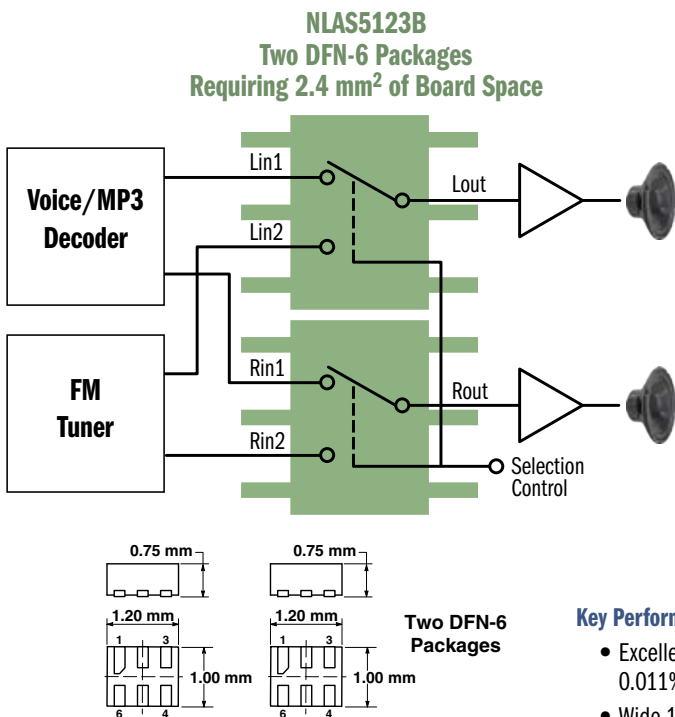

Key Performance Characteristics

- Excellent Audio Fidelity - Very Low THD, 0.011% Typical
- Wide 1.65 to 5.5 V Power Supply Range
- Extended Temperature Capable
- Low R_{DS(on)}, Tight Channel Matching

Low Capacitance Analog Switches for Data Switching

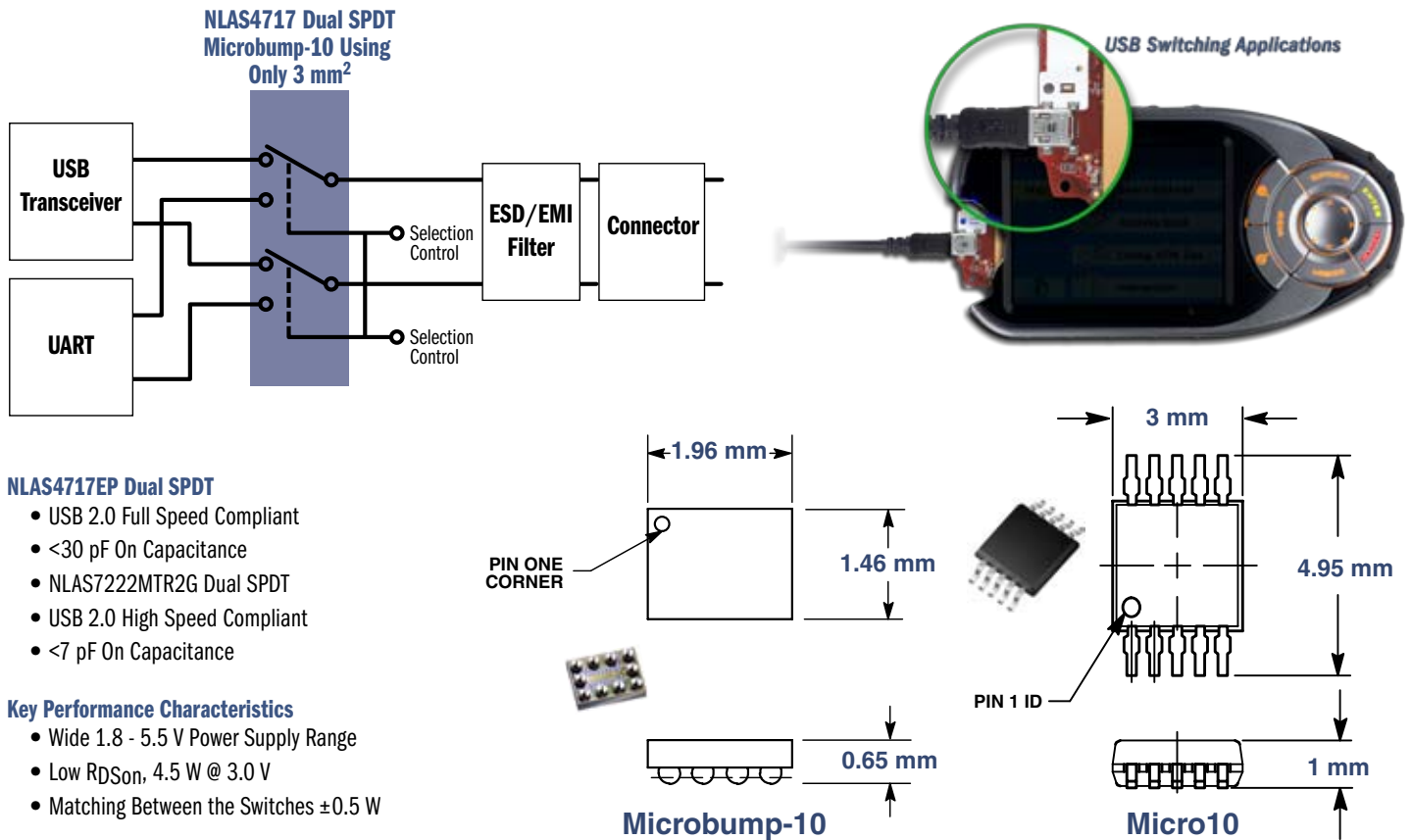

Ensure Low Drain Current with Voltage Supervisory Devices

Voltage Detection	NCP300/301 NCP302/303 NCP304/305	Under Voltage Sensing			
Reset Generator	MAX809/810 NCP803	Under Voltage Sensing	Reset Time-Out Counter		
μP Supervisor	MAX708	Under Voltage Sensing	Reset Time-Out Counter	Power Fail Comparator	Manual Reset

Key Performance Characteristics

- Lowest quiescent current for extended battery life
- Complete range of products
- Large number of voltage thresholds
- Wide operating voltage range up to 10 V

Supervisory Devices

Device	Function	Pertinent Features	Package
NCP300	Volt Detector	Complementary Output, No External Delay	SOT-23-5
NCP301	Volt Detector	Open Drain Output, No External Delay	SOT-23-5
NCP302	Volt Detector	Complementary Output, Programmable External Delay	SOT-23-5
NCP303	Volt Detector	Open Drain Output, Programmable External Delay	SOT-23-5
NCP304	Volt Detector	Complementary Output, No External Delay	SC-82AB
NCP305	Volt Detector	Open Drain Output, No External Delay	SC-82AB
MAX809	Reset Generator	140 mS, Minimum Output Reset-Low Delay	SOT-23
MAX810	Reset Generator	140 mS, Minimum Output Reset-High Delay	SOT-23
MAX803	Reset Generator	140 mS, Minimum Output Drain Output Reset-Low Delay	SOT-23
MAX708	μP Reset Mo	200 mS Push-Pull Output Reset Delay, Std Threshold	SO-8, Micro8™

Achieve Lower EMI with Spread-Spectrum Clock Synthesizers

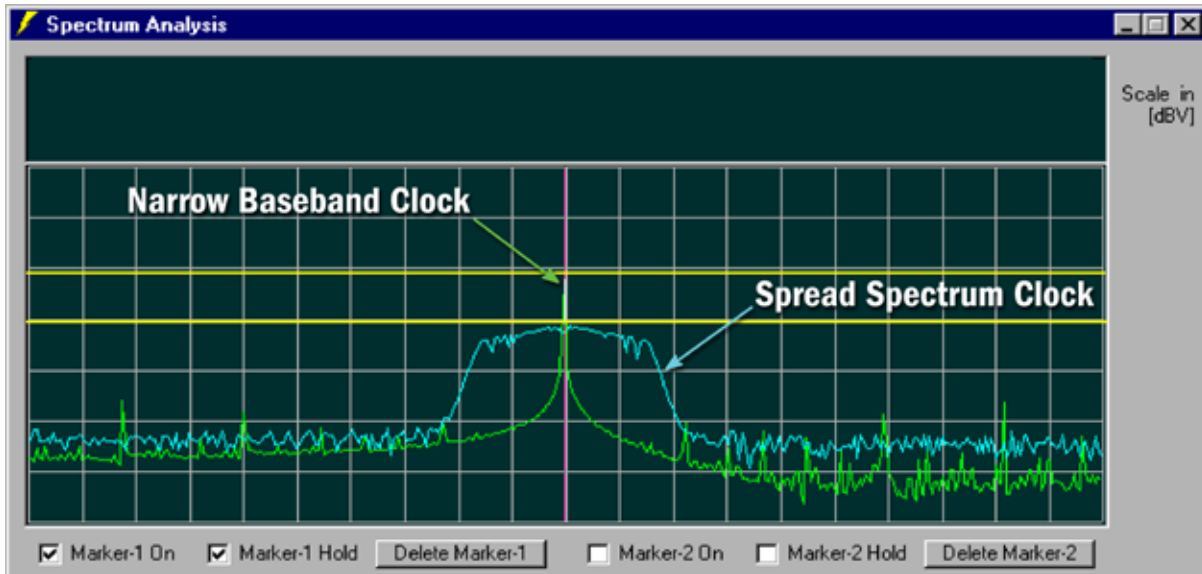

EMI Clock Synthesizers

Device	f_{in} (MHz)	Accepts Crystal Input	Accepts Reference Input	Power Down	Spread Spectrum Enable/Disable	Modulation Rate Equation	Output Frequency Deviation	Reference Output
NB2669A	6 - 13	N	Y	Y	N	$f_{in} \div 256$	$\pm 1\%$	N
NB2760A	6 - 13	Y	Y	Y	N	$f_{in} \div 256$	$\pm 0.75\%$	N
NB2762A	6 - 13	Y	Y	Y	N	$f_{in} \div 256$	-1.25%	N
NB2769A	6 - 13	Y	Y	Y	N	$f_{in} \div 256$	$\pm 1\%$	N
NB2869A	6 - 13	Y	Y	N	N	$f_{in} \div 256$	$\pm 1\%$	Y
NB2969A	6 - 13	Y	Y	N	N	$f_{in} \div 256$	$\pm 1\%$	Y, $\div 2$
NB2579A	13 - 30	Y	Y	N	Y	$f_{in} \div 640$	$\pm 1\%$	N
NB2779A	13 - 30	Y	Y	Y	N	$f_{in} \div 640$	$\pm 1\%$	N
NB2870A	13 - 30	Y	Y	N	N	$f_{in} \div 640$	$\pm 0.75\%$	Y
NB2872A	15 - 30	Y	Y	N	N	$f_{in} \div 640$	-1.25%	Y
NB2879A	15 - 30	Y	Y	N	N	$f_{in} \div 640$	$\pm 1\%$	Y
NB2780A	30 - 50	Y	Y	Y	N	$f_{in} \div 1280$	$\pm 0.75\%$	N

Key Performance Characteristics

- Replace ferrite beads and chokes
- Reduce peak EMI by 6 - 26 dBm
- Power Down mode reduces current draw to 4 μ A



LDO Voltage Regulators

Single Output Low-Dropout Linear Regulators (LDOs)

Device	I _{out}	Dropout* (typ)	I _q ** (typ)	PSRR****	Absolute Max Input Voltage	Package(s) - pins	V _{out}	Features
NCP512	80 mA	160 mV	40 µA	60 dB	6 V	SC-70-5	1.5, 1.8, 2.5, 2.7, 2.8, 3, 3.1, 3.3, 5 V	Enable
NCP553	80 mA	650 mV	2.8 µA	25 dB	12 V	SC82AB-4	1.5, 1.8, 2.5, 2.7, 2.8, 3, 3.3, 5 V	Ultra Low I _q , No Cap
LM2931A/C/AC	100 mA	160 mV	400 µA (@10mA)	90 dB	40 V	SO-8, TO-92-3, TO-220-3/5, DPAK-3, D2PAK-3/5	Adj, 5 V	High PSRR
LP2950C/AC	100 mA	350 mV	75 µA	–	30 V	DPAK-3, TO-92-3	3, 3.3, 5 V	Tight Line & Load Reg.
LP2951C/AC	100 mA	350 mV	75 µA	–	30 V	SO-8, Micro8, DIP-8	Adj, 3, 3.3, 5 V	Enable, Error Output
NCP612	100 mA	200 mV	40 µA	60 dB	6 V	SC-70-5	1.5, 1.8, 2.5, 2.7, 2.8, 3, 3.1, 3.3, 5 V	Enable
NCP662	100 mA	230 mV	2.5 µA	25 dB	6 V	SC82AB-4	1.5, 1.8, 2.5, 2.7, 2.8, 3, 3.3, 5 V	Enable, Ultra Low I _q
NCP663	100 mA	230 mV	2.5 µA	25 dB	6 V	SC82AB-4	1.5, 1.8, 2.5, 2.7, 2.8, 3, 3.3, 5 V	Ultra Low I _q
NCP580	120 mA	180 mV	90 µA	80 dB	6.5 V	SC82AB-4	1.5, 1.8, 2.5, 2.8, 3, 3.3 V	Enable, Ultra Low Noise
MC78PC	150 mA	200 mV (@100 mA)	35 µA	70 dB	9 V	SOT-23-5	1.8, 2.5, 2.8, 3, 3.3, 5 V	Enable, Ultra Low Noise
NCP500	150 mA	150 mV	175 µA	62 dB	6 V	SOT-23-5, (2x2.2) DFN-6	1.8, 1.85, 2.5, 2.6, 2.7, 2.8, 3, 3.3, 5 V	Enable, Fast Transient
NCP511	150 mA	90 mV (@100 mA)	40 µA	60 dB	6 V	SOT-23-5	1.5, 1.8, 2.5, 2.7, 2.8, 3, 3.3, 5 V	Enable
NCP551	150 mA	720 mV	4.0 µA	25 dB	12 V	SOT-23-5	1.5, 1.8, 2.5, 2.7, 2.8, 3, 3.3, 5 V	Enable, Ultra Low I _q
NCP623	150 mA	180 mV	170 µA	90 dB	12 V	Micro8, (3x3) DFN-6	3.3, 4, 5 V	Enable, Ultra Low Noise
NCP582	150 mA	220 mV	75 µA	70 dB	6.5 V	SOT-563-6, SC82AB-4	1.5, 1.8, 2.5, 2.8, 2.9, 3, 3.3 V	Enable, Ultra Low Noise
NCP583	150 mA	250 mV	1.0 µA	45 dB	6.5 V	SOT-563-6, SC82AB-4	1.5, 1.8, 2.5, 2.8, 2.9, 3, 3.3 V	Enable, Ultra Low I _q
NCP600****	150 mA	100 mV	175 µA	62 dB	6 V	SOT-23-5	Adj	Enable, Fast Turn-ON
NCP584	200 mA	200 mV	3.5 µA	75 dB	6.5 V	SOT-23-5	0.9, 1.2, 1.5 , 1.8, 2.6 , 3.1 V	Enable, Tri-Mode
MC33275	300 mA	260 mV	125 µA	75 dB	13 V	SO-8, DPAK-3, SOT-223-3, (4x4) DFN-8	2.5, 3, 3.3, 5 V	Tight Line & Load Reg.
NCP585	300 mA	310 mV	3.5 µA	75 dB	6.5 V	SOT-23-5, HSON-6	0.9, 1.2, 1.8 V	Enable, Tri-Mode
NCP3334****	500 mA	340 mV (max)	190 µA	–	16 V	SO-8	Adj	Enable, High Accuracy
NCP3335A	500 mA	340 mV (max)	190 µA	75 dB	16 V	Micro8, (3x3) DFN-10	Adj, 2.5, 2.85, 3.3, 5 V	Enable, High Accuracy

* Voltage dropout was measured at full load for V_{out} = 3.3 V where applicable unless noted.

** I_q was measured at 0 or 0.1 mA load unless noted

*** Release to Market in Q2-2006

**** PSRR was measured at f = 120 Hz for V_{out} = 3.3 when applicable.

Bold Denotes NEW Products, Packages, and/or Voltage Options

Contact an ON Sales Representative for other voltage options or for automotive grade regulators.

Key Performance Characteristics

- Maintains accuracy over full temperature and load current operating conditions

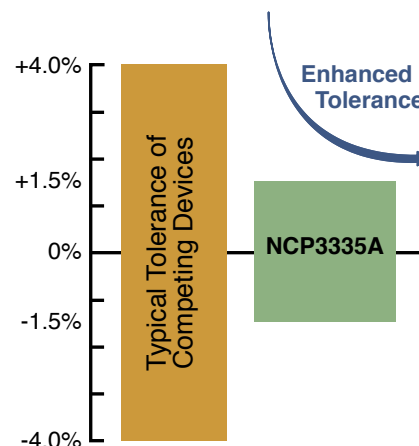

MiniGate™ Logic

Logic MiniGates

Function	Designator	NL17SV**XV5T2 SOT-553 Package	NL17SZ**DFT2G SOT-353 Package	NL17SZ**XV5T2 SOT-553 Package
2-Input NAND Gate	00	✓	✓	✓
2-Input NOR Gate	02	✓	✓	✓
Input Inverter	04	✓	✓	✓
Unbuffered Input Inverter	U04		✓	✓
Inverter, Open Drain	06		✓	✓
Non-Inverting Buffer, Open Drain	07		✓	✓
2-Input AND Gate	08	✓	✓	✓
Schmitt Inverter	14		✓	✓
Non-Inverting Buffer	16	✓	✓	✓
Schmitt Buffer	17		✓	✓
2-Input OR Gate	32	✓	✓	✓
2-Input XOR Gate	86		✓	
3-State, Non-Inverting Buffer, Active Low	125		✓	✓
3-State, Non-Inverting Buffer, Active High	126		✓	✓

Most devices also offered in Duals (NL27WZxx Series) or Triples (NL37WZxx Series)

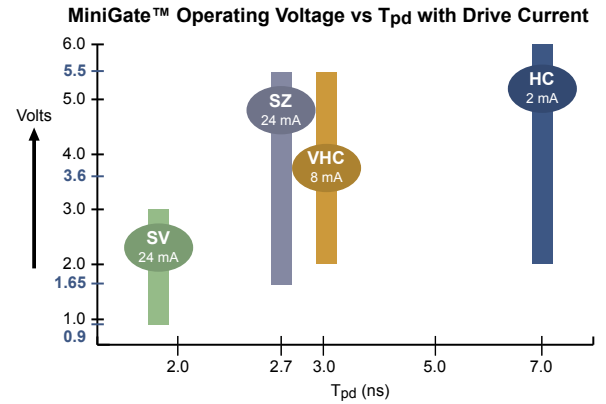

MiniGate™ Package Size Comparison - 5 Leads

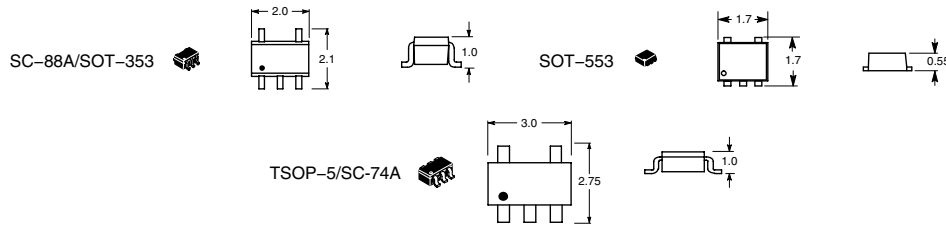

SIM/SAM Card Interface ICs

Key Features of NCN4555/7

- Single & Dual SIM interface (Subscriber Identity Module)
- Sequencer on NCN4557
- 1.8 V - 5.5 V Digital Input Voltage
- Fully compatible with ISO7816-3, GSM11.11/11.12/11.18, IMT-2000 / 3G TS 31.101
- Supports 1.8 V / 3 V Cards
- Linear DC-DC Converter (LDO) able to supply current in excess of 50 mA at 1.8 V & 3 V (Vbat ranging from 2.7 V to 5.5 V)
- Very low stand-by and operating power consumption
- >5 MHz clock frequency
- >7 kV HBM ESD protection on SIM pins
- Low profile 3 mm x 3 mm QFN-16 package



SIM Interface Device Comparison

Product Features	NCN4555	NCN4557
Analog Interfaces	1 card	2 cards
Card Types (V)	1.8/3	1.8/3
Max Clock Frequency (MHz)	>5	>5
Power Supply (Type)	Built-In LDO-Type DC-DC	Built-In LDO-Type DC-DC
Power Supply (V)	2.7 - 5.5	2.7 - 5.5
Activation/Deactivation	No	Yes
Packaging	Low Profile QFN-16	Low Profile QFN-16
Temperature Range (°C)	-25 to +85	-25 to +85
Wireless Protocol	GSM 11.1x/3G TS 31.101	GSM 11.1x/3G TS 31.101
ESD Protection (kV)	8	8

Sales and Design Assistance from ON Semiconductor



www.onsemi.com

ON Semiconductor Distribution Partners

All American	www.allamerican.com	(800) 573-2727
Arrow Electronics	www.arrow.com	(800) 777-2776
Avnet	www.em.avnet.com	(800) 332-8638
Chip Supply	www.chipsupply.com	(407) 298-7100
Digi-Key	www.digikey.com	(800) 338-1003
EBV Elektronik	www.ebv.com/en/locations.html	(49) 8121 774-0
Farnell InOne	www.farnellinone.com	+44 8701 200 200
Future Electronics Europe	www.futureelectronics.com/contact	info-eur-future@futureelectronics.com
Future & FAI Electronics	www.futureelectronics.com/contact	1-800-FUTURE1 (388-8731)
Minco	www.mincotech.com	(512) 834-2022
Newark Electronics	www.newark.com	(800) 4-NEWARK
Rochester Electronics	www.rocelec.com	(978) 462-9332
Semi Dice Inc	www.semidice.com	1 (800) 345-6633
Silica (An Avnet Company)	www.silica.com	+33 1 6447 2929
Spoerle	www.spoerle.de/de/about/offices	+49 6103 3040

INTERNATIONAL

BRAZIL	San Paulo	(55-11) 3842-8911
CHINA	Beijing	86-10-8518-2323
	Chengdu	86-28-8678-4078
	Shenzhen	86-755-8209-1128
	Shanghai	86-21-5131-7168
FRANCE	Paris	33 (0)1 39-26-41-00
GERMANY	Munich	49 (0) 89-93-0808-0

INTERNATIONAL

HONG KONG	Hong Kong	852-2689-0088
INDIA	Bangalore	91-80-2532-5084
ISRAEL	Herzeliya	972 (0) 9-9609-111
ITALY	Milan	39 02-530-0951
JAPAN	Tokyo	81-3-5773-3850
KOREA	Seoul	82-2-2190-3500
MALAYSIA	Penang	60-4-226-9368

INTERNATIONAL

MEXICO	Guadalajara	(5233) 3123-9199
SINGAPORE	Singapore	65-6391-1260
SLOVAKIA	Piestany	(421) 33 790 2320
TAIWAN	Taipei	886-2-2377-9911
UNITED KINGDOM	Slough	44 (0) 1296-610400

NORTH AMERICA SALES OFFICES & REP FIRMS

Alabama	Huntsville	e-Components	(256) 533-2444
	Huntsville	ON Sales Office	(256) 774-1004
Arizona	Phoenix	Compass Southwest	(480) 763-0968
California	Santa Clara	T3 Technical Sales	(408) 350-3900
	Irvine	Compass Southwest	(949) 580-0270
	San Diego	Compass Southwest	(858) 635-5959
CANADA	All Regions	Astec	(905) 607-1444
Colorado	Englewood	ON Sales Office	Kari Hill: (720) 895-1367 Mike Barone: (303) 670-8000
Connecticut	Monroe	Impact Technical Sales	(203) 268-7229
Florida	Boca Raton	e-Components	(561) 289-1379
	Lake Mary	e-Components	(407) 804-0042
	Plantation	ON Sales Office	(954) 325-1223
	Palm Harbor	e-Components	(727) 937-3016
	Melbourne	e-Components	(321) 676-5659
Georgia	Duluth	e-Components	(678) 380-5080
Illinois	Hoffman Estates	Stan Clothier	(847) 781-4010
Indiana	Fishers	Bear VAI	(317) 570-0707
	Kokomo	ON Sales Office	(765) 865-2091
Iowa	Cedar Rapids	Stan Clothier	(319) 393-1576
Kansas	Overland Park	Stan Clothier	(913) 894-1675
Maryland	Columbia	Third Wave Solutions	(410) 290-5990
Massachusetts	Burlington	Impact Technical Sales	(781) 238-8888
	Lowell	ON Sales Office	(978) 452-6075
Michigan	Livonia	ON Sales Office	(734) 953-6848
Minnesota	Eden Prairie	Stan Clothier	(952) 944-3456
Missouri	St. Charles	Stan Clothier	(636) 916-3777
New Jersey	Denville	CJR Associates	(973) 625-2796
New York	Long Island	CJR Associates	(973) 625-2796
	New York City	CJR Associates	(973) 625-2796
	Rochester	TriTech	(716) 385-6500
	Binghamton	TriTech	(607) 722-3580
Ohio	Brecksville	Bear VAI	(937) 748-1341
Oregon	Portland	SiFore Technical Sales	(503) 977-6267
Pennsylvania	Hatboro	Delta Technical Sales	(215) 957-0600
Texas	Austin	West Associates	(512) 343-1199
	Richardson	West Associates	(972) 680-2800
Washington	Bellevue	SiFore Technical Sales	(425) 990-4701
Wisconsin	Statewide	Stan Clothier	(847) 781-4010

µCool and MiniGate are trademarks of SCILLC. Micro8 is a trademark of International Rectifier. FETKY is a registered trademark of International Rectifier. ChipFET is a trademark of Vishay Siliconix. POWERMITE is a registered trademark of Microsemi Corporation.

ON Semiconductor and the ON logo are registered trademarks of Semiconductor Components Industries, LLC (SCILLC). SCILLC reserves the right to make changes without further notice to any products herein. SCILLC makes no warranty, representation or guarantee regarding the suitability of its products for any particular purpose, nor does SCILLC assume any liability arising out of the application or use of any product or circuit, and specifically disclaims any and all liability, including without limitation special, consequential or incidental damages. "Typical" parameters which may be provided in SCILLC data sheets and/or specifications can and do vary in different applications and actual performance may vary over time. All operating parameters, including "Typicals" must be validated for each customer application by customer's technical experts. SCILLC does not convey any license under its patent rights nor the rights of others. SCILLC products are not designed, intended, or authorized for use as components in systems intended for surgical implant into the body, or other applications intended to support or sustain life, or for any other application in which the failure of the SCILLC product could create a situation where personal injury or death may occur. Should Buyer purchase or use SCILLC products for any such unintended or unauthorized application, Buyer shall indemnify and hold SCILLC and its officers, employees, subsidiaries, affiliates, and distributors harmless against all claims, costs, damages, and expenses, and reasonable attorney fees arising out of, directly or indirectly, any claim of personal injury or death associated with such unintended or unauthorized use, even if such claim alleges that SCILLC was negligent regarding the design or manufacture of the part. SCILLC is an Equal Opportunity/Affirmative Action Employer. This literature is subject to all applicable copyright laws and is not for resale in any manner.

PUBLICATION ORDERING INFORMATION

LITERATURE FULFILLMENT:

Literature Distribution Center for ON Semiconductor
P.O. Box 5163, Denver, Colorado 80217 USA
Phone: 303-675-2175 or 800-344-3860 Toll Free USA/Canada
Fax: 303-675-2176 or 800-344-3867 Toll Free USA/Canada
Email: orderlit@onsemi.com

N. American Technical Support: 800-282-9855 Toll Free
USA/Canada.

Europe, Middle East and Africa Technical Support:
Phone: 421 33 790 2910

Japan Customer Focus Center
Phone: 81-3-5773-3850

ON Semiconductor Website: www.onsemi.com

Order Literature: <http://www.onsemi.com/orderlit>

For additional information, please contact your local
Sales Representative