

OPAMP1EVB

Op Amp Evaluation Board Manual SOT23, SC70, and SOIC8 Package



ON Semiconductor®

<http://onsemi.com>

Description

This document describes the SOT23, SC70, and SOIC8 package Op Amp evaluation board. It should be used in conjunction with the appropriate data sheet which contains full technical details on the device specification and operation. This evaluation board is offered as a convenience for the customers interested in performing their own engineering characterization and performance assessment. The evaluation board provides a 50 Ω controlled impedance environment. The evaluation board is designed to facilitate a quick evaluation of the device. The default populated evaluation board will have a gain of two.

This evaluation board manual contains:

- Information on OP1SOT23EVB (SOT23 package) Evaluation Board

- Information on OP1SC70EVB (SC70 package) Evaluation Board
- Information on OP1SOIC8EVB (SOIC8 package) Evaluation Board
- Bill of Materials

Board Lay-up

The SOT23, SC70, and SOIC8 evaluation boards are implemented in two layers (Figure 1, Evaluation Board Lay-up). The first layer is the 1.0 oz copper ground plane, where a portion of the ground plane is cut out to mount the device. The FR4 dielectric material is placed between the first and second layer. The second layer contains the rest of the components and primary signal traces.

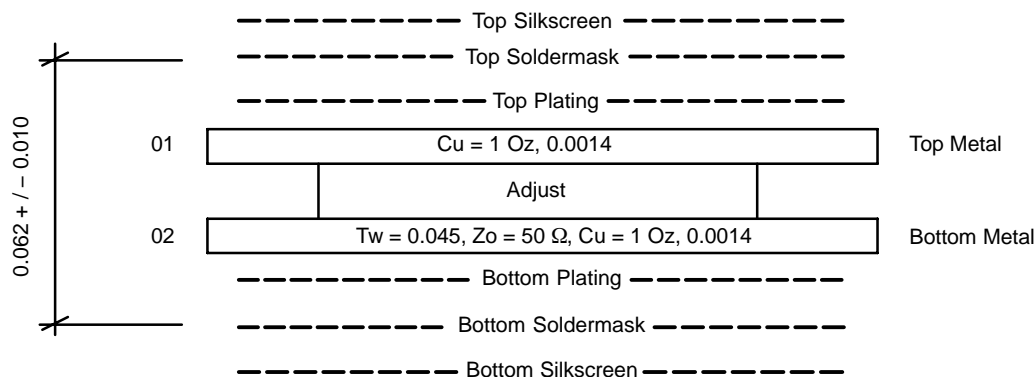

Figure 1. Evaluation Board Lay-up

Board Design

The evaluation board was designed for non-inverting op amp configuration (Figure 2). The input contains termination resistor R3 (usually 50 Ω). The input can also be monitored through J1 when R1 and R2 are populated. The

evaluation board has versatile loading options for the op amp through C9, R10, and R11 depending on the user's preference it can be configured as capacitive load, series resistance load, parallel resistance load, etc.

OPAMP1EVB

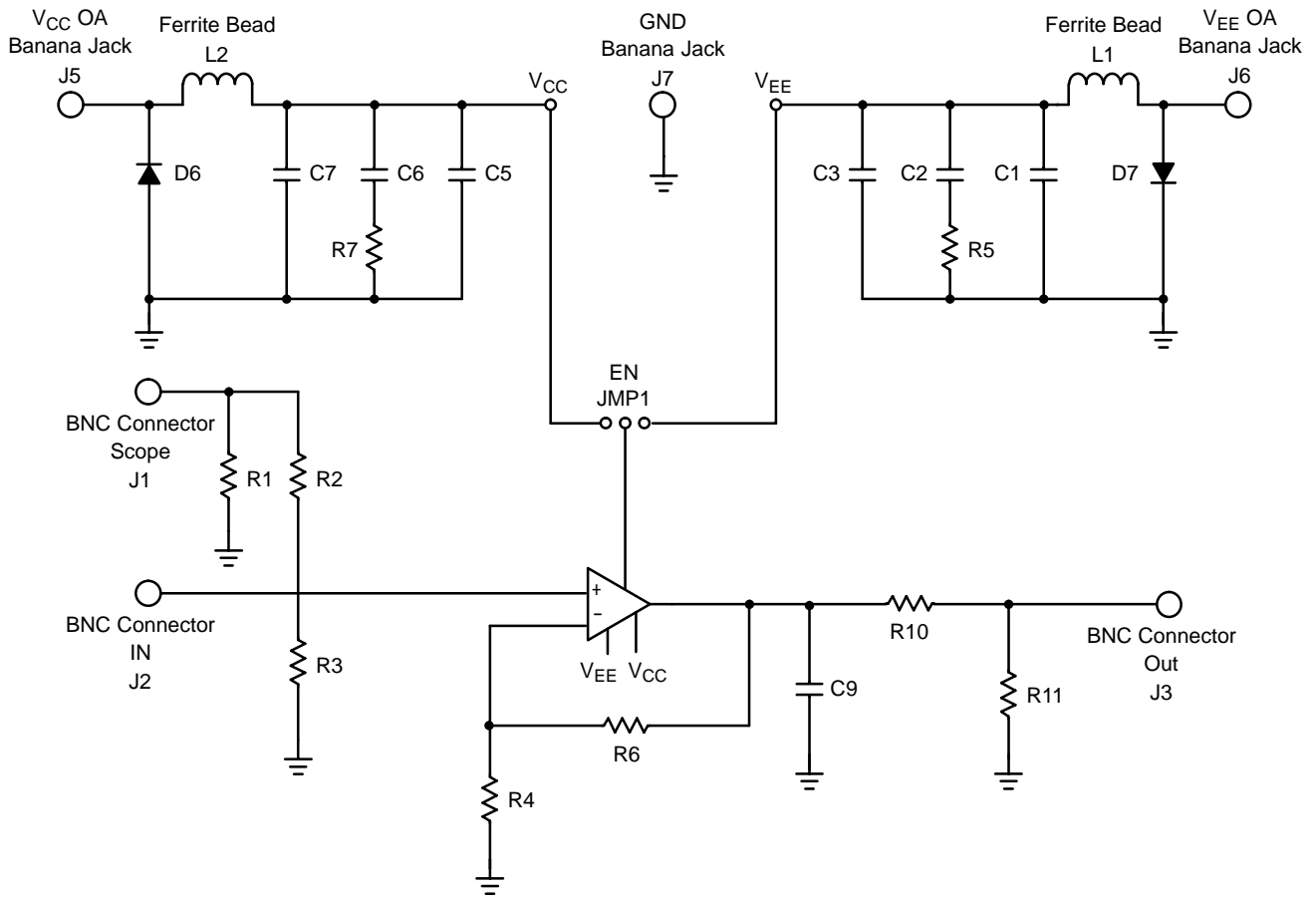

Figure 2. Evaluation Board Schematic

- L1, L2, C1, C2, C3, C5, C6, C7, D6, D7, R5, and R7 are for power supply noise suppression
- R3 is for input matching of 50 Ω trace
- R1 and R2 are for monitoring the input signal
- R4 and R6 are for feedback resistors
- C9, R10, and R11 are for different loading configuration of the op amp
- If enable pin is available, the Jumper 1 can be used to enable or disable the device

OPAMP1EVB

Board Layout

Figure 3 shows the board layout of the SOT23 package (SC70 board layout is similar to SOT23 board layout) and Figure 4 shows the board layout of the SOIC8 package.

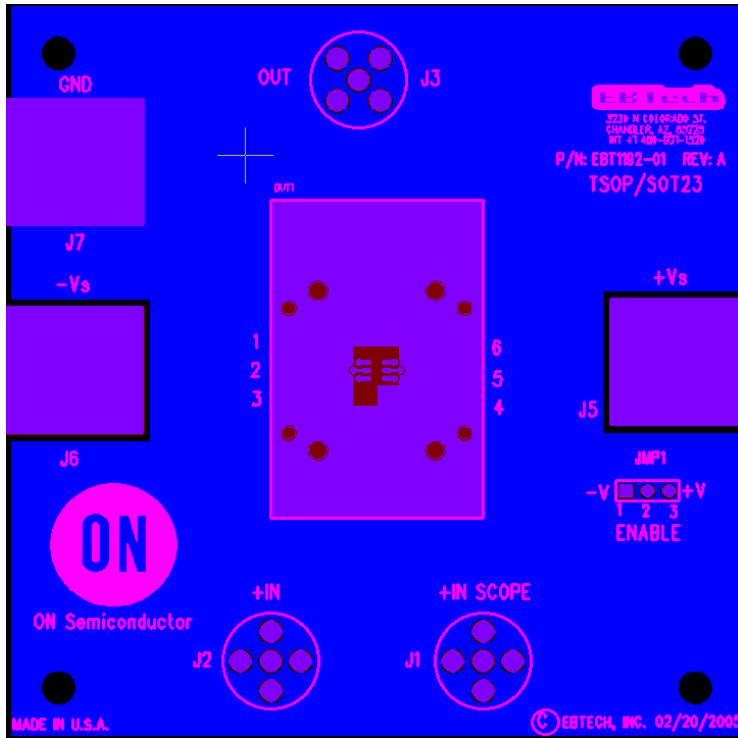

Top View

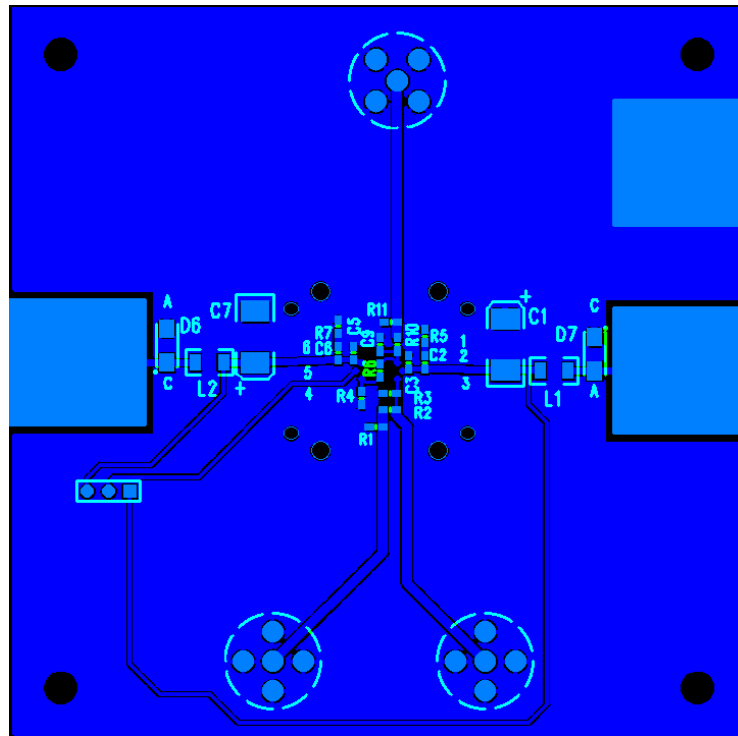

Bottom View

Figure 3. SOT23 Evaluation Board Layout

OPAMP1EVB

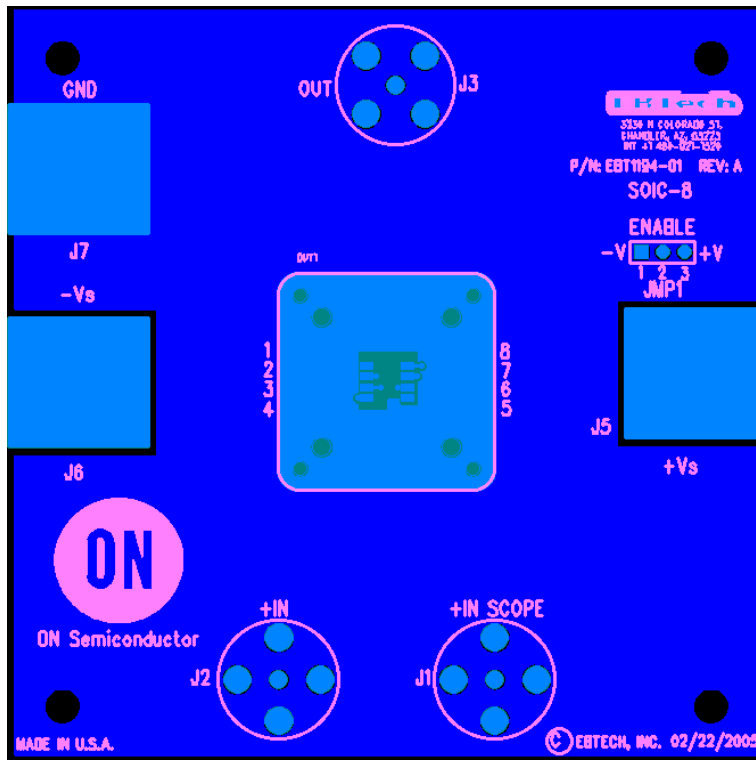

Top View

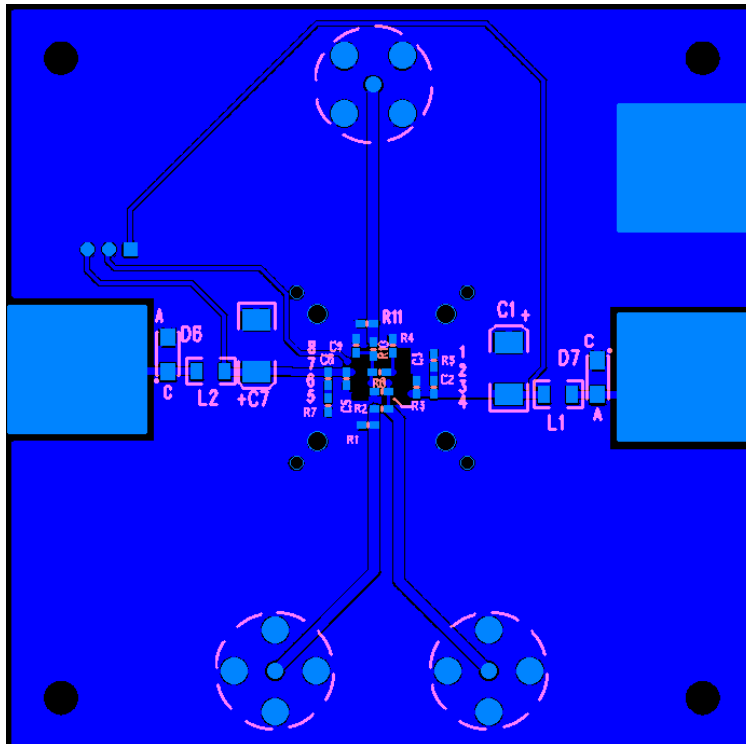

Bottom View

Figure 4. SOIC-8 Evaluation Board Layout

OPAMP1EVB

Package	ON P/N	Manufacturer	Manufacturer P/N
SOT23	OP1SOT23EVB	EB Tech	EBT1192-01
SC70	OP1SC70EVB	EB Tech	EBT1193-01
SOIC8	OP1SOIC8EVB	EB Tech	EBT1194-01

NOTE: Each evaluation board can be assembled with all components listed in the following BOMs.

BOM for NCS2500, NCS2501, and NCS2502

Item	Qty	Ref Des	Value	Package	Description	MFG	Part Number
1	2	C1,C7	4.7 μ F		CAPACITOR TANT 4.7 μ F 25 V 10% SMD	Kemet	T491C475K025AS
2	2	C2,C6	47 nF	0603	CAP CER 47000 PF 50 V X7R 10% 0603	TDK Corporation	C1608X7R1H473K
3	2	C3,C5	330 pF	0603	CAP CER 330 PF 50 V C0G 5% 0603	TDK Corporation	C1608C0G1H331J
4	2	D6,D7			DIODE STD REC 1.0 A 300 V SMA	ON Semiconductor	MRA4003T3
5	3	J1-J3		BNC	CONN JACK BNC VERT 50 Ω PCB	AMP/TYCO	414305-1
6	3	J4-J6			CONN JACK BANANA UNINS PANEL MOU	Johnson Components Inc.	108-0740-001
7	2	L1,L2			BEAD CORE 68 Ω 3.0 A 1206 SMD	Panasonic - ECG	EXC-ML32A680U
8	1	R2	450 Ω	0603	RES 453 Ω 1/10 W 1% 0603 SMD	Yageo America	9C06031A4530FKHFT
9	1	R3	50 Ω	0603	RES 49.9 Ω 1/10 W 1% 0603 SMD	Yageo America	9C06031A49R9FKHFT
10	2	R5,R7	2.2 Ω	0603	RES 2.2 Ω 1/10 W 5% 0603 SMD	Yageo America	9C06031A2R20JGHFT
11	1	R4	1.2 k Ω	0603	RES 1.2 k Ω 1/10 W 1% 0603 SMD	Yageo America	9C06031A1201JGHFT
12	1	R6	1.2 k Ω	0603	RES 1.2 k Ω 1/10 W 1% 0603 SMD	Yageo America	9C06031A1201JGHFT
13	1	R10	50 Ω	0603	RES 49.9 Ω 1/10 W 1% 0603 SMD	Yageo America	9C06031A49R9FKHFT
14	3	JMP1			CONN HEADER .100 SINGL STR 36POS	Sullins Electronics Corp.	PTC36SABN
15	1	JMP1			CONN JUMPER SHORTING TIN	Sullins Electronics Corp.	STC02SYAN
16	4				Standoffs, washer, nut		
Parts Not Installed							
17	1	C9		0603	NO VALUE DEFINED, TBD		
18	2	R1,R11		0603	RES 49.9 Ω 1/10 W 1% 0603 SMD	Yageo America	9C06031A49R9FKHFT

NOTE: Assembled board has a default gain of +2.0. There is an attenuation factor of two when used in conjunction with a 50 Ω termination resistance of the measuring instrument.

OPAMP1EVB

BOM for NCS2510 and NCS2511

Item	Qty	Ref Des	Value	Package	Description	MFG	Part Number
1	2	C1,C7	4.7 μ F		CAPACITOR TANT 4.7 μ F 25 V 10% SMD	Kemet	T491C475K025AS
2	2	C2,C6	47 nF	0603	CAP CER 47000 PF 50 V X7R 10% 0603	TDK Corporation	C1608X7R1H473K
3	2	C3,C5	330 pF	0603	CAP CER 330 PF 50 V C0G 5% 0603	TDK Corporation	C1608C0G1H331J
4	2	D6,D7			DIODE STD REC 1.0 A 300 V SMA	ON Semiconductor	MRA4003T3
5	3	J1-J3		BNC	CONN JACK BNC VERT 50 Ω PCB	AMP/TYCO	414305-1
6	3	J4-J6			CONN JACK BANANA UNINS PANEL MOU	Johnson Components Inc.	108-0740-001
7	2	L1,L2			BEAD CORE 68 Ω 3.0 A 1206 SMD	Panasonic - ECG	EXC-ML32A680U
8	1	R2	450 Ω	0603	RES 453 Ω 1/10 W 1% 0603 SMD	Yageo America	9C06031A4530FKHFT
9	1	R3	50 Ω	0603	RES 49.9 Ω 1/10 W 1% 0603 SMD	Yageo America	9C06031A49R9FKHFT
10	2	R5,R7	2.2 Ω	0603	RES 2.2 Ω 1/10 W 5% 0603 SMD	Yageo America	9C06031A2R20JGHFT
11	1	R4	400 Ω	0603	RES 400 Ω 1/10 W 1% 0603 SMD	Yageo America	9C06031A3900JGHFT
12	1	R6	400 Ω	0603	RES 400 Ω 1/10 W 1% 0603 SMD	Yageo America	9C06031A3900JGHFT
13	1	R10	100 Ω	0603	RES 100 Ω 1/10 W 1% 0603 SMD	Yageo America	9C06031A1000FKHFT
14	3	JMP1			CONN HEADER .100 SINGL STR 36POS	Sullins Electronics Corp.	PTC36SABN
15	1	JMP1			CONN JUMPER SHORTING TIN	Sullins Electronics Corp.	STC02SYAN
16	4				Standoffs, washer, nut		
NO NOT INSTALL THESE PARTS -							
17	1	C9		0603	NO VALUE DEFINED, TBD		
18	2	R1,R11		0603	RES 49.9 Ω 1/10 W 1% 0603 SMD	Yageo America	9C06031A49R9FKHFT

NOTE: Assembled board has a default gain of +2.0. There is an attenuation factor of three when used in conjunction with a 50 Ω termination resistance of the measuring instrument.

OPAMP1EVB

BOM for NCS2550, NCS2551, and NCS2552

Item	Qty	Ref Des	Value	Package	Description	MFG	Part Number
1	2	C1,C7	4.7 μ F		CAPACITOR TANT 4.7 μ F 25 V 10% SMD	Kemet	T491C475K025AS
2	2	C2,C6	47 nF	0603	CAP CER 47000 PF 50 V X7R 10% 0603	TDK Corporation	C1608X7R1H473K
3	2	C3,C5	330 pF	0603	CAP CER 330 PF 50 V C0G 5% 0603	TDK Corporation	C1608C0G1H331J
4	2	D6,D7			DIODE STD REC 1.0 A 300 V SMA	ON Semiconductor	MRA4003T3
5	3	J1-J3		BNC	CONN JACK BNC VERT 50 Ω PCB	AMP/TYCO	414305-1
6	3	J4-J6			CONN JACK BANANA UNINS PANEL MOU	Johnson Components Inc.	108-0740-001
7	2	L1,L2			BEAD CORE 68 Ω 3.0 A 1206 SMD	Panasonic - ECG	EXC-ML32A680U
8	1	R2	450 Ω	0603	RES 453 Ω 1/10 W 1% 0603 SMD	Yageo America	9C06031A4530FKHFT
9	1	R3	50 Ω	0603	RES 49.9 Ω 1/10 W 1% 0603 SMD	Yageo America	9C06031A49R9FKHFT
10	2	R5,R7	2.2 Ω	0603	RES 2.2 Ω 1/10 W 5% 0603 SMD	Yageo America	9C06031A2R20JGHFT
11	1	R4	150 Ω	0603	RES 150 Ω 1/10 W 1% 0603 SMD	Yageo America	9C06031A1500JGHFT
12	1	R6	150 Ω	0603	RES 150 Ω 1/10 W 1% 0603 SMD	Yageo America	9C06031A1500JGHFT
13	1	R10	100 Ω	0603	RES 100 Ω 1/10 W 1% 0603 SMD	Yageo America	9C06031A1000FKHFT
14	3	JMP1			CONN HEADER .100 SINGL STR 36POS	Sullins Electronics Corp.	PTC36SABN
15	1	JMP1			CONN JUMPER SHORTING TIN	Sullins Electronics Corp.	STC02SYAN
16	4				Standoffs, washer, nut		
NO NOT INSTALL THESE PARTS -							
17	1	C9		0603	NO VALUE DEFINED, TBD		
18	2	R1,R11		0603	RES 49.9 Ω 1/10 W 1% 0603 SMD	Yageo America	9C06031A49R9FKHFT

NOTE: Assembled board has a default gain of +2.0. There is an attenuation factor of three when used in conjunction with a 50 Ω termination resistance of the measuring instrument.

OPAMP1EVB

ON Semiconductor and **ON** are registered trademarks of Semiconductor Components Industries, LLC (SCILLC). SCILLC reserves the right to make changes without further notice to any products herein. SCILLC makes no warranty, representation or guarantee regarding the suitability of its products for any particular purpose, nor does SCILLC assume any liability arising out of the application or use of any product or circuit, and specifically disclaims any and all liability, including without limitation special, consequential or incidental damages. "Typical" parameters which may be provided in SCILLC data sheets and/or specifications can and do vary in different applications and actual performance may vary over time. All operating parameters, including "Typicals" must be validated for each customer application by customer's technical experts. SCILLC does not convey any license under its patent rights nor the rights of others. SCILLC products are not designed, intended, or authorized for use as components in systems intended for surgical implant into the body, or other applications intended to support or sustain life, or for any other application in which the failure of the SCILLC product could create a situation where personal injury or death may occur. Should Buyer purchase or use SCILLC products for any such unintended or unauthorized application, Buyer shall indemnify and hold SCILLC and its officers, employees, subsidiaries, affiliates, and distributors harmless against all claims, costs, damages, and expenses, and reasonable attorney fees arising out of, directly or indirectly, any claim of personal injury or death associated with such unintended or unauthorized use, even if such claim alleges that SCILLC was negligent regarding the design or manufacture of the part. SCILLC is an Equal Opportunity/Affirmative Action Employer. This literature is subject to all applicable copyright laws and is not for resale in any manner.

PUBLICATION ORDERING INFORMATION

LITERATURE FULFILLMENT:

Literature Distribution Center for ON Semiconductor
P.O. Box 61312, Phoenix, Arizona 85082-1312 USA

Phone: 480-829-7710 or 800-344-3860 Toll Free USA/Canada

Fax: 480-829-7709 or 800-344-3867 Toll Free USA/Canada

Email: orderlit@onsemi.com

N. American Technical Support: 800-282-9855 Toll Free
USA/Canada

Japan: ON Semiconductor, Japan Customer Focus Center

2-9-1 Kamimeguro, Meguro-ku, Tokyo, Japan 153-0051

Phone: 81-3-5773-3850

ON Semiconductor Website: <http://onsemi.com>

Order Literature: <http://www.onsemi.com/litorder>

For additional information, please contact your
local Sales Representative.