

# ADSL Magnetics



TM02393

- Designed to comply with the requirements of Analog Devices' Anaconda and Diamondback ADSL over POTS reference designs
- Designed to comply with the requirements of UL60950 and EN60950 safety requirements for ADSL applications
- Minimum interwinding breakdown voltage of 1500 Vrms
- Operating and storage temperature range: -40° to +85° C
- Meets IEC 695, 2-2 flammability requirements
- PWB Process Capability: standard printed wiring board assembly techniques, total-immersion cleaning
- Reliability testing: shock, vibration, temperature cycling, temperature - humidity - bias

## ELECTRICAL SPECIFICATIONS AT 25° C

Part Number	Turns Ratio ±2%	Inductance <sup>1</sup> mH ±10%	Leakage Inductance µH max	DCR Ω max		Longitudinal Balance <sup>2</sup> dB min	Insertion Loss <sup>2</sup> dB max	Frequency Response <sup>2</sup> dB max	Harmonic Distortion <sup>2</sup> dB max
	Chip : Line	Line Side	Line Side	Chip Side	Line Side	100 kHz - 1.1 MHz	300 kHz	100 kHz - 1.1 MHz	4 Vac 40 kHz
S560-6600-DB	1 : 1.1	2	10	3.4	3.8	46	0.5	±0.5	-80

All measurements are made with pins 2 and 3 connected and pins 6 and 7 connected

1. Inductance measured at 10 kHz, 0.1 Vac
2. Measured with line impedance of 100 Ω

## SCHEMATIC

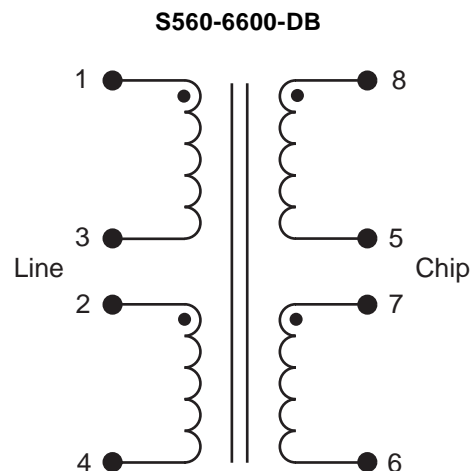

©2002 Bel Fuse Inc. Specifications subject to change without notice. 01.02

TM02393

### MECHANICAL

S560-6600-DB

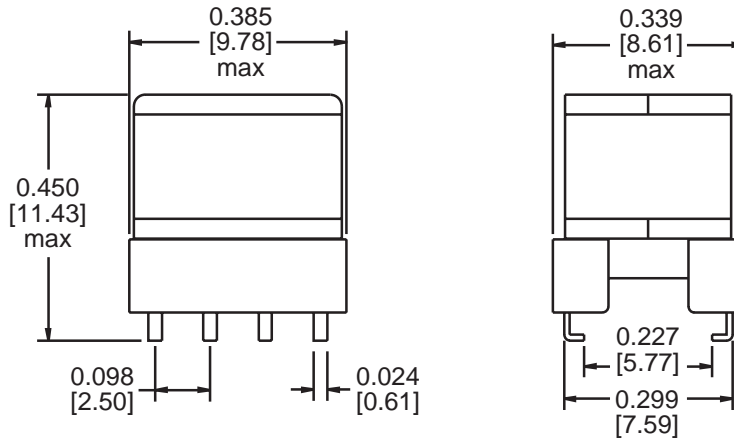
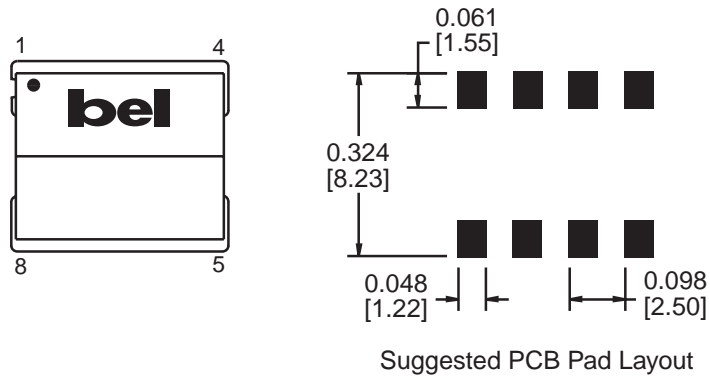

Dimensions are in inches [millimeters].  
Standard dimension tolerance is  $\pm 0.005$  [0.13] unless otherwise noted.

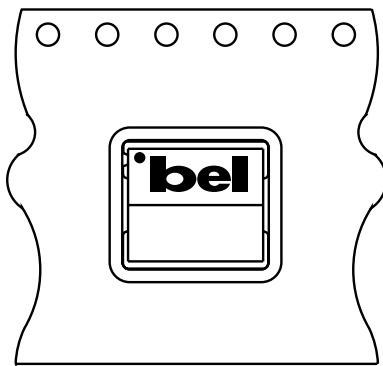

➔ User Feed Direction

Orientation of Component Inside Pocket

### Tape and Reel Packaging

24 mm wide by 16 mm pitch; 13 inch OD, 4 inch ID  
300 components per reel, maximum  
Meets ANSI/EIA 481-2 Carrier Tape Standards

©2002 Bel Fuse Inc. Specifications subject to change without notice. 01.02

### CORPORATE

**Bel Fuse Inc.**  
206 Van Vorst Street  
Jersey City, NJ 07302  
Tel 201-432-0463  
Fax 201-432-9542  
www.belfuse.com

### FAR EAST

**Bel Fuse Ltd.**  
8F / 8 Luk Hop Street  
San Po Kong  
Kowloon, Hong Kong  
Tel 852-2328-5515  
Fax 852-2352-3706  
www.belfuse.com

### EUROPE

**Bel Fuse Europe Ltd.**  
Preston Technology Management Centre  
Marsh Lane, Suite G7, Preston  
Lancashire, PR1 8UD, U.K.  
Tel 44-1772-556601  
Fax 44-1772-888366  
www.belfuse.com