



## RE46C129

### CMOS Ionization Smoke Detector ASIC with Interconnect Product Specification

#### General Description

The RE46C129 is low power CMOS ionization type smoke detector IC. With few external components this circuit will provide all the required features for an ionization type smoke detector.

An internal oscillator strobes power to the smoke detection circuitry for 10.5mS every 1.66 seconds to keep standby current to a minimum. A check for a low battery condition is performed every 40 seconds when in standby.

An interconnect pin allows multiple detectors to be connected such that when one units alarms all units will sound.

Although this device was designed for smoke detection utilizing an ionization chamber it could be used in a variety of security applications.

Utilizing low power CMOS technology the RE46C129 was designed for use in smoke detectors that comply with Underwriters Laboratory Specification UL217 and UL268.

#### Features

- Guard Outputs for Ion Detector Input
- +/-0.75pA Detect Input Current
- Internal Reverse Battery Protection
- Low Quiescent Current Consumption (<6.5uA)
- Available in 16L PDIP or 16L N SOIC
- ESD Protection on all Pins
- Internal Low Battery Detection
- Interconnect up to 40 Detectors
- Compatible with Allegro A5350
- Available in Standard Packaging or RoHS Compliant Pb Free Packaging.

#### Pin Configuration

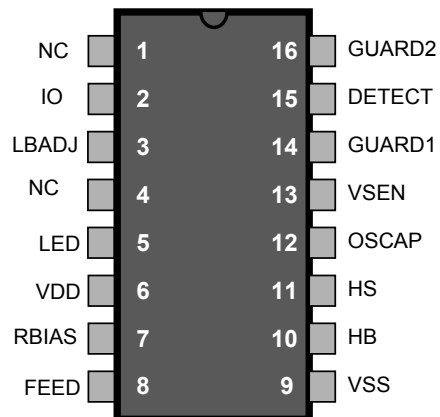

#### ABSOLUTE MAXIMUM RATINGS

PARAMETER	SYMBOL	VALUE	UNITS
Supply Voltage	$V_{DD}$	15	V
Input Voltage Range Except FEED, IO	$V_{in}$	-3 to $V_{dd} + .3$	V
FEED Input Voltage Range	$V_{infd}$	-10 to +22	V
IO Input Voltage Range	$V_{io1}$	-3 to 17	V
Reverse Battery Time	$T_{RB}$	5	S
Input Current except FEED	$I_{in}$	10	mA
Operating Temperature	$T_A$	-10 to 60	°C
Storage Temperature	$T_{STG}$	-55 to 125	°C
Maximum Junction Temperature	$T_J$	150	°C

Stresses beyond those listed under Absolute Maximum Ratings may cause permanent damage to the device. These are stress ratings only and operation at these conditions for extended periods may affect device reliability.

This product utilizes CMOS technology with static protection; however proper ESD prevention procedures should be used when handling this product. Damage can occur when exposed to extremely high static electrical charge.

# RE46C129

CMOS Ionization Smoke Detector ASIC with Interconnect  
Product Specification



DC Electrical Characteristics at TA = 25°C, VDD=9V, OSCAP=.1uF, RBIAS=8.2MΩ, VSS=0V (unless otherwise noted)

Parameter	Symbol	Test Pin	Test Conditions	Limits			
				Min	Typ	Max	Units
Supply Voltage	V <sub>DD</sub>	6	Operating	6		12	V
Supply Current	I <sub>DD1</sub>	6	RBIAS=8.2MΩ, OSCAP=.1uF		4	6.5	uA
	I <sub>DD2</sub>	6	RBIAS=8.2MΩ, OSCAP=.1uF;Vdd=12V			9	uA
Input Voltage High	V <sub>IH1</sub>	8	FEED Input	6.3			V
	V <sub>IH2</sub>	2	No Local Alarm, IO as an Input	3			V
Input Voltage Low	V <sub>IL1</sub>	8	FEED Input			2.7	V
	V <sub>IL2</sub>	2	No Local Alarm, IO as an Input			1	V
Input Leakage Low	IL <sub>DET1</sub>	15	VDD=9V, DETECT=VSS, 0-40% RH			-0.75	pA
	IL <sub>DET2</sub>	15	VDD=9V, DETECT=VSS, 85% RH Note 1			-1.50	pA
	IL <sub>FD</sub>	8	FEED=-10V			-50	uA
Input Leakage High	IH <sub>DET1</sub>	15	VDD=9V, DETECT=VDD, 0-40% RH			0.75	pA
	IH <sub>DET2</sub>	15	VDD=9V, DETECT=VDD, 85% RH Note 1			1.50	pA
	IH <sub>FD</sub>	8	FEED=22V			50	uA
	I <sub>IOL2</sub>	2	No Alarm, Vio=17V			150	uA
Output Off Leakage High	I <sub>IOHZ</sub>	5	Outputs Off			1	uA
Output High Voltage	V <sub>OH1</sub>	10,11	IOH=-16mA, VDD=7.2V	6.3			V
Output Low Voltage	V <sub>OL1</sub>	10,11	IOL=16mA, VDD=7.2V			.9	V
	V <sub>OL3</sub>	5	IOL=10mA, VDD=7.2V			1	V
Output Current	I <sub>IOL1</sub>	2	No Alarm, Vio=Vdd-2V	25		100	uA
	I <sub>IOH1</sub>	2	Alarm, Vio=Vdd-2V or Vio=0V	-4		-16	mA
	I <sub>IODMP</sub>	2	At Conclusion of Local Alarm or Test, Vio=1V	5			mA
Low Battery Voltage	V <sub>LB</sub>	6	T <sub>A</sub> =-10 to 60°C, Note 3	7.2	7.5	7.8	V
Internal Sensitivity Set Voltage	V <sub>SET2</sub>	3			65.5		%V <sub>DD</sub>
Offset Voltage	V <sub>GOS1</sub>	14,15	Guard Amplifier	-50		50	mV
	V <sub>GOS2</sub>	15,16	Guard Amplifier	-50		50	mV
	V <sub>GOS3</sub>	13,15	Smoke Comparator	-50		50	mV
Common Mode Voltage	V <sub>CM1</sub>	14,15	Guard Amplifier, Note 2	2		V <sub>DD</sub> -5	V
	V <sub>CM2</sub>	13,15	Smoke Comparator, Note 2	.5		V <sub>DD</sub> -2	V
Output Impedance	Z <sub>OUT</sub>	14,16	Guard Amplifier Outputs, Note 2		10		kΩ

Note 1: Sample test only

Note 2: Not 100% production tested

Note 3: Production test at room with temperature guardbanded limits.

# RE46C129

CMOS Ionization Smoke Detector ASIC with Interconnect  
Product Specification



AC Electrical Characteristics at TA = 25°C, VDD=9V, OSCAP=.1uF, RBIAS=8.2MΩ, VSS=0V (unless otherwise noted)

Parameter	Symbol	Test Pin	Test Conditions	Limits			
				Min	Typ	Max	Units
Oscillator Period	T <sub>PER1</sub>	12	No Alarm Condition	1.34	1.67	2	S
	T <sub>PER2</sub>	12	Alarm Condition	37.5	41.5	45.8	mS
Oscillator Pulse Width	T <sub>PW</sub>	5	Operating	9.4	10.5	12.9	mS
LED On Time	T <sub>LOn</sub>	5	Operating	9.4	10.5	12.9	mS
LED Off Time	T <sub>LOF1</sub>	5	Standby, No Alarm	32	40	48	S
	T <sub>LOF2</sub>	5	Alarm Condition	.8	1	1.2	S
Horn On Time	T <sub>HON1</sub>	10,11	Operating, Alarm Condition	141	166	190	mS
	T <sub>HON2</sub>	10,11	Low Battery, No Alarm	9.4	10.5	12.9	mS
Horn Off Time	T <sub>HOF1</sub>	10,11	Operating, Alarm Condition	71	83	95	mS
	T <sub>HOF3</sub>	10,11	Low Battery, No Alarm	32	40	48	S
IO Charge Dump Duration	T <sub>IODMP</sub>	2	At Conclusion of Local Alarm or Test	1.34	1.67	2.0	S
IO Delay	T <sub>IODLY1</sub>	2	From Start of Local Alarm to IO Active		3		S
IO Filter	T <sub>IOFILT</sub>	2	IO pulse width guaranteed to be filtered. IO as Input, No Local Alarm			450	mS
Remote Alarm Delay	T <sub>IODLY2</sub>	2	No Local Alarm, IO as input, From IO active to Horn Active	.450		2.2	S

# RE46C129

CMOS Ionization Smoke Detector ASIC with Interconnect  
Product Specification



## Functional Block Diagram

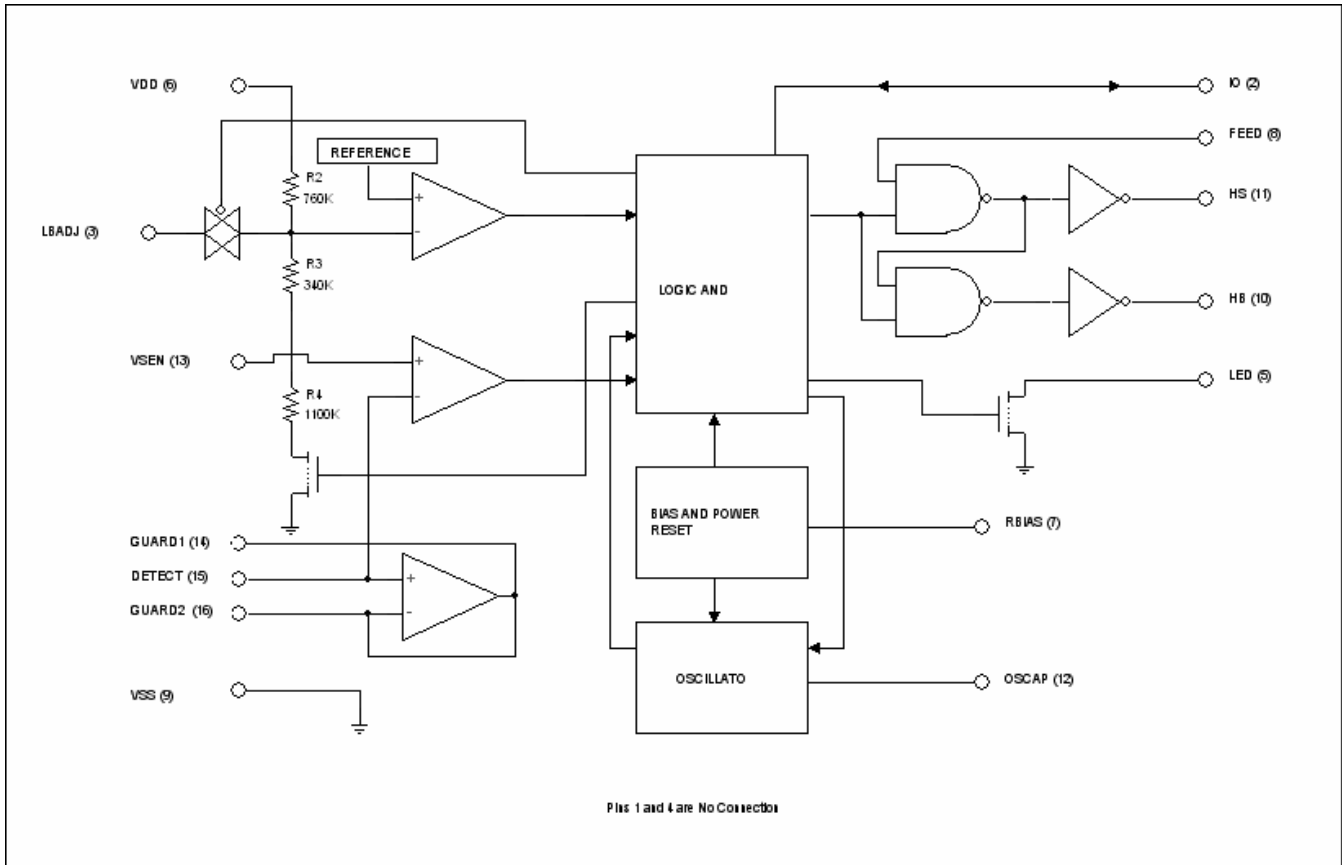

---

## DEVICE DESCRIPTION and APPLICATION NOTES

Internal Timing – With external components as indicated on the application drawing the period of the oscillator is nominally 1.67 seconds in standby. Every 1.66 seconds the detection circuitry is powered up for 10.5mS and the status of the smoke comparator is latched. In addition every 40 seconds the LED driver is turned on for 10.5mS and the status of the low battery comparator is latched. The smoke comparator status is not checked during the low battery test, during the low battery horn warning chirp, or when the horn is on due to an alarm condition.

If an alarm condition is detected the oscillator period increases to 41.5mS. In any alarm condition the horn is on for 166mS and off for 83mS (typical).

Due to the low currents used in the oscillator the capacitor on pin 12 should be a low leakage type. Oscillator accuracy will depend mainly on the tolerance of the RBIAS resistor and OSCAP capacitor.

Smoke Detection Circuit – The smoke comparator compares the ionization chamber voltage to a voltage derived from a resistor divider across VDD. This divider voltage must be provided externally on pin 13 (VSEN). See the application drawing (FIG 2).

The guard amplifier and outputs are always active and will be within 50mV of the DETECT input to reduce surface leakage. The guard outputs also allow for measurement of the DETECT input without loading the ionization chamber.

Low Battery Detection - An internal reference is compared to the voltage divided VDD supply. The battery can be checked under load via the LED low side driver output since low battery status is latched at the end of the 10.5mS LED pulse. Pin 3 (LBADJ) can be used to modify the low battery set point by placing a resistor to VDD or VSS. The transmission switch on LBADJ is turned on during the LED pulse so an external resistance can be added on pin 3 to modify the set point if desired.

LED Pulse – The LED is pulsed on for 10.5mS every 40S in standby. In alarm the LED is pulsed on for 10.5mS every 1S.

Interconnect – Pin 2 (IO) provides the capability to common many detectors in a single system. If a single unit goes into alarm the IO pin is driven high. This high signal causes the interconnected units to alarm. The LED flashes every 1S for 10.5mS on the signaling unit and is inhibited on the units that are in alarm due to the active IO signal. An internal sink device on the IO pin helps to discharge the interconnect line. This charge dump device is active for 1 clock cycle after the unit exits a local alarm condition (1.67S).

The interconnect input has a 500mS nominal digital filter which will filter out pulsed signals on the IO pin. This allows for interconnection to other types of alarms (carbon monoxide for example) that may have a pulsed interconnect signal. This filter will eliminate unwanted random horn activations caused by a pulsed (<500ms nominal) IO input signal.

Testing - By holding pin 12 (OSCAP) low the internal power strobe is active. Functional testing can be accelerated by driving pin 12 with a 4kHz square wave however the 10.5mS strobe period must be maintained for proper operation of the analog circuitry. Please refer to the timing diagrams. All internal timing is reset after a power up. By holding pins 8 and 12 low, reducing VDD and monitoring Pin 10 the low battery trip level can be measured at power up.

# RE46C129

CMOS Ionization Smoke Detector ASIC with Interconnect  
Product Specification



## Typical Application

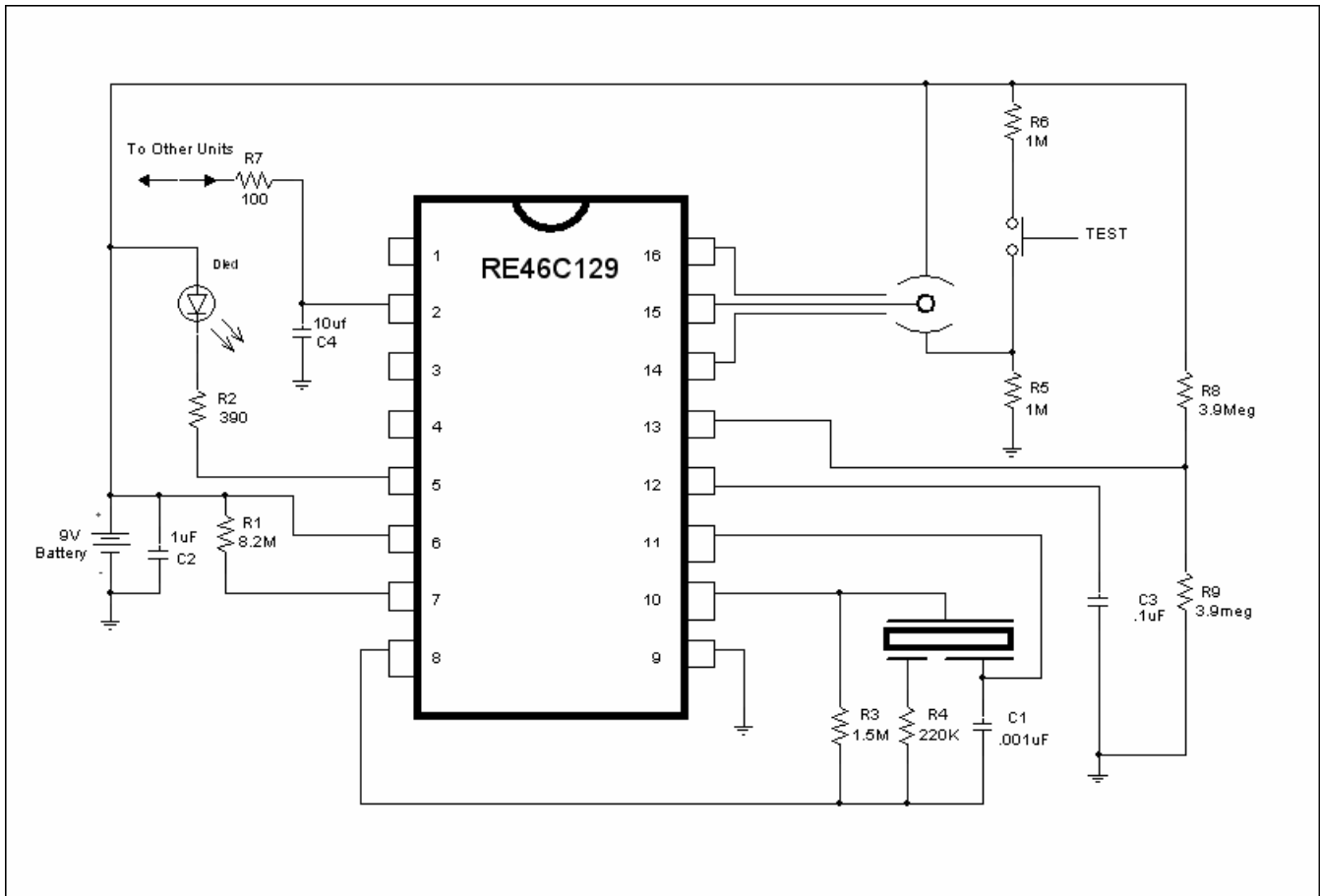
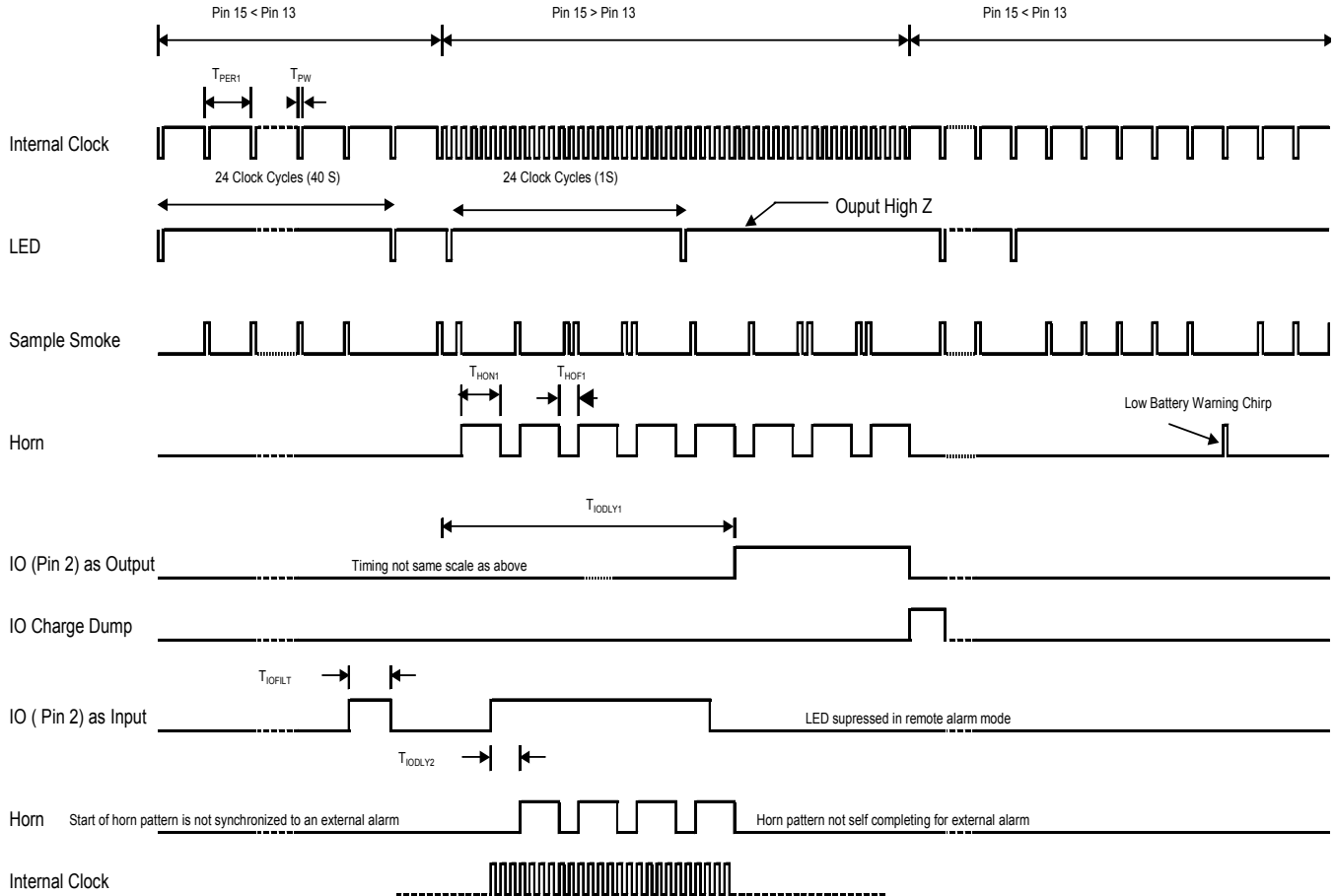

Figure 2

### Notes:

- 1) C2 should be located as close as possible to the device power pins.
- 2) Select R8 and R9 to set the smoke chamber sensitivity.
- 3) Low battery trip can be modified by external resistance on pin 3, see device description.

## Timing Diagram



### Notes:

1. Smoke is not sampled when the horn is active. Horn cycle is self completing in local alarm.
2. Low battery warning chirp is suppressed in local or remote alarm.
3. IO Dump active only in local alarm, inactive if external alarm.

# RE46C129

**CMOS Ionization Smoke Detector ASIC with Interconnect**  
Product Specification



---

**R&E INTERNATIONAL, Inc.** reserves the right to make changes without further notice to any products herein to improve reliability, function or design.

**R&E INTERNATIONAL, Inc.** does not assume any liability arising out of the application or use of any product or circuit described herein; neither does it convey any license under its patent rights, nor the rights of others.

**R&E INTERNATIONAL, Inc.** products are not authorized for use as critical components in life support devices or systems without the express written approval of the President of **R&E INTERNATIONAL, Inc.** Life support devices or systems are devices or systems which are intended for surgical implant into the body to support or sustain life, and whose failure to perform, when properly used in accordance with instructions for use provided in the labeling, can be reasonably expected to result in a significant injury to the user. A critical component is any component of a life support device or system whose failure to perform can be reasonably expected to cause the failure of the life support device or system, or to affect its safety or effectiveness.