

STRUCTURE	Silicon Monolithic Integrated Circuit
PRODUCT NAME	Pre-Driver For 3Phase Brushless Motor
TYPE	BD6926FV
FEATURES	<ul style="list-style-type: none"> •MOS-FET Pre-Driver •120° phase Direct PWM input

○ABSOLUTE MAXIMUM RATINGS (Ta=25°C)

Parameter	Symbol	Limit	Unit
Power Supply Voltage	VCC	7	V
Output Current	I _{OMAX}	40 *1	mA
Input voltage	V _{IN}	0~VCC	V
AL terminal voltage	V _{AL}	7	V
AL output current	I _{ALMAX}	10	mA
FG, FG3 terminal voltage	V _{FG}	7	V
FG, FG3 output current	I _{FGMAX}	5	mA
Power dissipation	Pd	1025 *2	mW
Operating temperature range	T _{opr}	-40~+85	°C
Junction temperature	T _{jmax}	+150	°C
Storage temperature range	T _{stg}	-55~+150	°C

*1 Must not exceed Pd, ASO or Tjmax=150°C.

*2 Reduce by 8.2mW/°C over 25°C, when mounted on a glass epoxy board (70mm×70mm×1.6mm).

○Operating Conditions (Ta=-40~+85°C)

Power Supply voltage	VCC	4.0~6.0	V
----------------------	-----	---------	---

*This product is not designed for normal operation within a radio active environment.

*Status of this document

The Japanese version of this document is the formal specification.

A customer may use this translation version only for a reference to help reading the formal version.

If there are any differences in translation version of this document, formal version takes priority.

○Electrical Characteristics (Unless otherwise specified, Ta=25°C, VCC=5V)

Parameter	Symbol	Limit			Unit	Conditions
		Min.	Typ.	Max.		
<Overall>						
Circuit Current1	ICC1	2.2	4.6	7.0	mA	ST/SP=H
Circuit Current2	ICC2	—	—	10	μA	ST/SP=L
<UVLO>						
UVLO voltage	VUVLO	2.25	2.75	3.25	V	
hysteresis voltage	ΔVUVLO	0.35	0.50	0.65	V	
<ST/SP>						
ST voltage	VST	2.5	—	—	V	
SP voltage	VSP	—	—	1.0	V	
<Hall Comparator>						
Input Bias current	IHA	-3.0	-0.7	-	μA	
Common phase input voltage range	VHAR	1.0	—	3.5	V	
Input level	VINH	60	—	—	mVpp	
hysteresis voltage H	VHYSH	+8	+15	+22	mV	
hysteresis voltage L	VHYSL	-18	-11	-4	mV	
Hall maximum frequency	fHall	-	-	50	kHz	※guarantee of design
<Upper side output>						
Upper side output voltage	VHG	—	0.50	0.70	V	I _L =+30mA
<Lower side output>						
Lower side output voltage 1	VLG1	4.00	4.50	-	V	I _L =-30mA
Lower side output voltage 2	VLG2	—	0.50	0.70	V	I _L =+30mA
<Over current detection>						
Detection voltage	VTH	0.07	0.10	0.13	V	
Input voltage range	VIN	0.0	—	VCC	V	
Input bias current	IIB	-5.0	-0.9	-0.1	μA	
<Frequency for lock protection>						
Triangle wave peak	VLDCP	1.38	1.72	2.06	V	
Triangle wave bottom	VLDCL	0.8	1.0	1.2	V	
Charge current	ILDC	2.30	3.65	5.00	μA	
Lock detection output voltage	VALL	0.10	0.30	0.50	V	I _{AL} =10mA
Lock detection output leak current	IALL	—	0	10	μA	
<PWM input>						
ON voltage	VPWMO N	2.5	—	—	V	
OFF voltage	VPWMO F	—	—	1.0	V	
PWM frequency	fPWM	10	20	100	kHz	※guarantee of design
<FG(3) output>						
Output voltage	VFG(3)L	0.10	0.30	0.50	V	I _{FG} =5mA
Output leak current	IFG(3)L	—	0	10	μA	
<Hall Bias>						
Output voltage	VHBL	0.60	0.87	1.20	V	I _{HB} =10mA
Output leak current	IHBL	—	0	10	μA	
<CW/CCW>						
CW voltage	VF	—	—	1.0	V	
CCW voltage	VR	2.5	—	—	V	
<Short Brake>						
ON voltage	VSBON	2.5	—	—	V	
OFF voltage	VSOFF	—	—	1.0	V	

* Design target value (No total shipped devices are fully tested.)

● PHYSICAL DIMENSIONS-MARKING

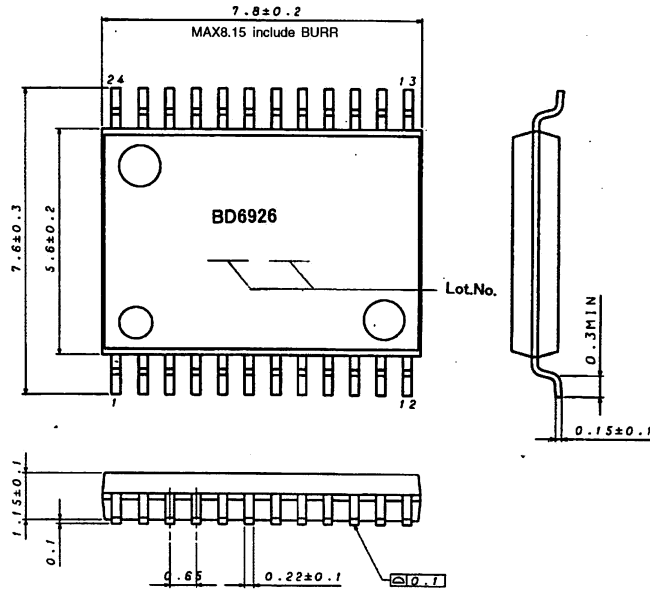

SSOP-B24 (UNIT:mm)

● BLOCK DIAGRAM

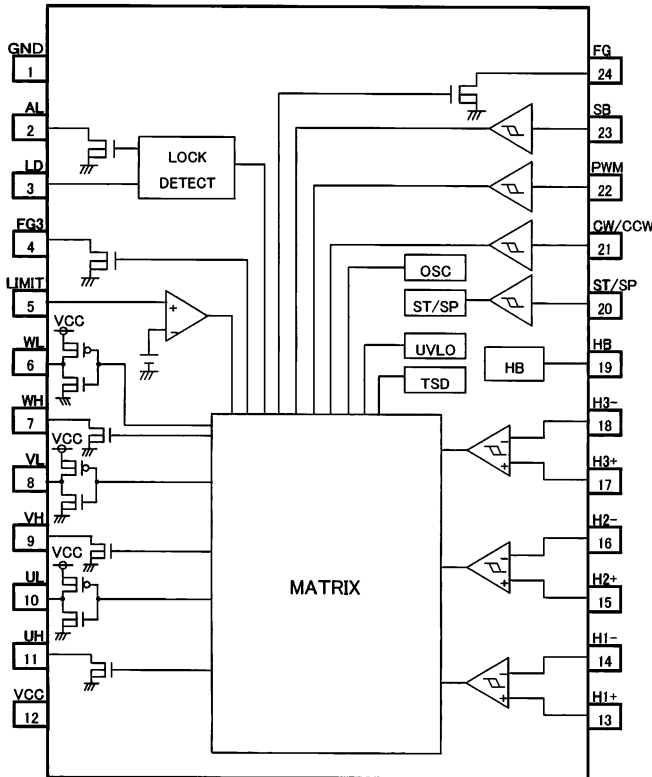

● Pin No, Pin Name, Function

PIN No	Pin name	Function
1	GND	GND
2	AL	Lock detection pin
3	LD	Lock protection pin
4	FG3	FG(Composition of 3phase) pin
5	LIMIT	Current limit pin
6	WL	Output WL pin
7	WH	Output WH pin
8	VL	Output VL pin
9	VH	Output VH pin
10	UL	Output UL pin
11	UH	Output UH pin
12	VCC	Power supply pin
13	H1+	Hall input H1+ pin
14	H1-	Hall input H1- pin
15	H2+	Hall input H2+ pin
16	H2-	Hall input H2- pin
17	H3+	Hall input H3+ pin
18	H3-	Hall input H3- pin
19	HB	Hall bias pin
20	ST/SP	Start/Stop pin
21	CW/CCW	CW/CCW pin
22	PWM	PWM input pin
23	SB	Short brake pin
24	FG	FG(Composition of 1phase) pin

* Refer to the Technical Note about the details of the application.

● Operation Notes

(1) Absolute maximum ratings

Use of the IC in excess of absolute maximum ratings, such as the applied voltage (VCC) or operating temperature range (Topr), may result in IC damage. Assumptions should not be made regarding the state of the IC (short mode or open mode) when such damage is suffered. A physical safety measure, such as a fuse, should be implemented when using the IC at times where the absolute maximum ratings may be exceeded.

(2) Power Supply and Ground Wiring

The motor ground PGND pin is not connected to the IC GND pin. Separate the large-current PGND from the signal GND, and make one common ground point at a single reference point. These configurations will eliminate ground fluctuation between power sections and signal sections of the circuit. An overshooting, undershooting, or oscillation, on the power supply line, can occur due to instantaneous load fluctuations, which in turn, is due to a slow response of the power supply to instantaneous response. Fluctuating voltage on the power supply and ground lines may damage the device. Be sure to connect a bypass filter capacitor (1μF to 100μF) as close as possible to the IC between the power supply and ground pins. Check that the selected capacitance will not have an adverse influence on any characteristics, such as a drop in the electrolytic capacitor value that can occur at low temperatures. If it is necessary, add zener diode protection. The power supply and ground lines must be as short and thick as possible to reduce line impedance.

(3) Ground potential

Ensure a minimum GND pin potential in all operating conditions. Make sure that no pins are at a voltage below the GND at any time, regardless of whether it is a transient signal or not.

(4) Thermal design

Use a proper thermal design that allows for a sufficient margin of the power dissipation (Pd) at actual operating conditions.

(5) Pin short and wrong direction assembly of the device.

Use caution when positioning the IC for mounting on printed circuit boards. The IC may be damaged if there is any connection error or if positive and ground power supply terminals are reversed. The IC may also be damaged if pins are shorted together or are shorted to other circuit's power lines.

(6) Avoiding strong magnetic field

Malfunction may occur if the IC is used around a strong magnetic field.

(7) ASO

Ensure that the output transistors of the motor driver are not driven under excess conditions of the absolute maximum ratings and ASO.

(8) TSD (Thermal Shut Down) circuit

If the junction temperature (Tjmax) reaches 175°C (Typ.), the TSD circuit will operate, and the coil output circuit of the motor will open. There is a temperature hysteresis of approximately 25°C (Typ.). The TSD circuit is designed only to shut off the IC in order to prevent runaway thermal operation. It is not designed to protect the IC or guarantee its operation. The performance of the IC's characteristics is not guaranteed and it is recommended that the device is replaced after the TSD is activated.

(9) Testing an application board

When testing the IC on an application board, connecting a capacitor to a pin with low impedance subjects the IC to stress. Always discharge capacitors after each process or step. Always turn the IC's power supply off before connecting it to, or removing it from a jig or fixture, during the inspection process. Ground the IC during assembly steps as an antistatic measure. Use similar precaution when transporting and storing the IC.

(10) Regarding the input pin of the IC

This monolithic IC contains P⁺ isolation and P substrate layers between adjacent elements to keep them isolated. P-N junctions are formed at the intersection of these P layers with the N layers of other elements, creating a parasitic diode or transistor. For example, the relation between each potential is as follows:

When GND > Pin A, the P-N junction operates as a parasitic diode.

When GND > Pin B, the P-N junction operates as a parasitic diode and transistor.

Parasitic elements can occur inevitably in the structure of the IC. The operation of parasitic elements can result in mutual interference among circuits, operational faults, or physical damage. Accordingly, methods by which parasitic elements operate, such as applying a voltage that is lower than the GND (P substrate) voltage to an input pin, should not be used.

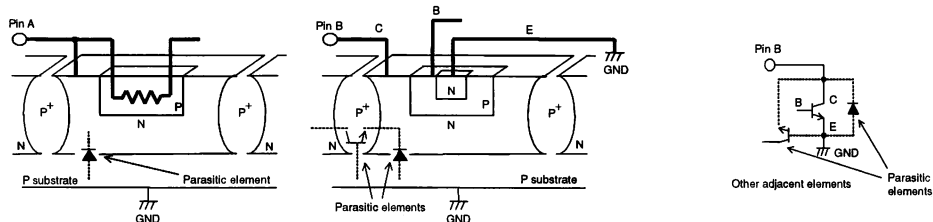

Example of Simple IC Architecture

Notes

- No technical content pages of this document may be reproduced in any form or transmitted by any means without prior permission of ROHM CO.,LTD.
- The contents described herein are subject to change without notice. The specifications for the product described in this document are for reference only. Upon actual use, therefore, please request that specifications to be separately delivered.
- Application circuit diagrams and circuit constants contained herein are shown as examples of standard use and operation. Please pay careful attention to the peripheral conditions when designing circuits and deciding upon circuit constants in the set.
- Any data, including, but not limited to application circuit diagrams information, described herein are intended only as illustrations of such devices and not as the specifications for such devices. ROHM CO.,LTD. disclaims any warranty that any use of such devices shall be free from infringement of any third party's intellectual property rights or other proprietary rights, and further, assumes no liability of whatsoever nature in the event of any such infringement, or arising from or connected with or related to the use of such devices.
- Upon the sale of any such devices, other than for buyer's right to use such devices itself, resell or otherwise dispose of the same, no express or implied right or license to practice or commercially exploit any intellectual property rights or other proprietary rights owned or controlled by
- ROHM CO., LTD. is granted to any such buyer.
- Products listed in this document are no antiradiation design.

The products listed in this document are designed to be used with ordinary electronic equipment or devices (such as audio visual equipment, office-automation equipment, communications devices, electrical appliances and electronic toys).

Should you intend to use these products with equipment or devices which require an extremely high level of reliability and the malfunction of which would directly endanger human life (such as medical instruments, transportation equipment, aerospace machinery, nuclear-reactor controllers, fuel controllers and other safety devices), please be sure to consult with our sales representative in advance.

About Export Control Order in Japan

Products described herein are the objects of controlled goods in Annex 1 (Item 16) of Export Trade Control Order in Japan.

In case of export from Japan, please confirm if it applies to "objective" criteria or an "informed" (by MITI clause) on the basis of "catch all controls for Non-Proliferation of Weapons of Mass Destruction.

Thank you for your accessing to ROHM product informations.
More detail product informations and catalogs are available,
please contact your nearest sales office.

Please contact our sales offices for details ;

U.S.A / San Diego	TEL : +1(858)625-3630	FAX : +1(858)625-3670
Atlanta	TEL : +1(770)754-5972	FAX : +1(770)754-0691
Dallas	TEL : +1(972)312-8818	FAX : +1(972)312-0330
Germany / Dusseldorf	TEL : +49(2154)9210	FAX : +49(2154)921400
United Kingdom / London	TEL : +44(1)908-282-666	FAX : +44(1)908-282-528
France / Paris	TEL : +33(0)1 56 97 30 60	FAX : +33(0) 1 56 97 30 80
China / Hong Kong	TEL : +852(2)740-6262	FAX : +852(2)375-8971
Shanghai	TEL : +86(21)6279-2727	FAX : +86(21)6247-2066
Dilian	TEL : +86(411)8230-8549	FAX : +86(411)8230-8537
Beijing	TEL : +86(10)8525-2483	FAX : +86(10)8525-2489
Taiwan / Taipei	TEL : +866(2)2500-6956	FAX : +866(2)2503-2869
Korea / Seoul	TEL : +82(2)8182-700	FAX : +82(2)8182-715
Singapore	TEL : +65-6332-2322	FAX : +65-6332-5662
Malaysia / Kuala Lumpur	TEL : +60(3)7958-8355	FAX : +60(3)7958-8377
Philippines / Manila	TEL : +63(2)807-6872	FAX : +63(2)809-1422
Thailand / Bangkok	TEL : +66(2)254-4890	FAX : +66(2)256-6334

Japan /
(Internal Sales)

Tokyo	2-1-1, Yaesu, Chuo-ku, Tokyo 104-0082	TEL : +81(3)5203-0321	FAX : +81(3)5203-0300
Yokohama	2-4-8, Shin Yokohama, Kohoku-ku, Yokohama, Kanagawa 222-8575	TEL : +81(45)476-2131	FAX : +81(45)476-2128
Nagoya	Dainagayo Building 9F 3-28-12, Meieki, Nakamura-ku, Nagoya, Aichi 450-0002	TEL : +81(52)581-8521	FAX : +81(52)561-2173
Kyoto	579-32 Higashi Shiokouji-cho, Karasuma Nishi-iru, Shiokoujidori, Shimogyo-ku, Kyoto 600-8216	TEL : +81(75)311-2121	FAX : +81(75)314-6559

(Contact address for overseas customers in Japan)

Yokohama	TEL : +81(45)476-9270	FAX : +81(045)476-9271
----------	-----------------------	------------------------