

INTEGRATED CONNECTOR MODULES

0863-2X6R-54 Gigabit Ethernet MagJack® 2 x 6 with LEDs

BI-COLOR LED POLARITY		
PIN	GREEN	ORANGE
11	-	+
12	+	-

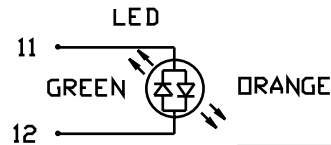

ELECTRICAL CHARACTERISTICS @ 25°C

URNS RATIO

TP1	1CT : 1CT ±2%
TP2	1CT : 1CT ±2%
TP3	1CT : 1CT ±2%
TP4	1CT : 1CT ±2%

OCL @ 100kHz/100mVRMS

8mA DC BIAS	350µH MIN.
-------------	------------

INS. LOSS

0.1MHz TO 1MHz	-1.1 dB MAX
1MHz TO 65MHz	-0.5 dB MAX
65MHz TO 100MHz	-0.8 dB MAX
100MHz TO 125MHz	-1.2 dB MAX

RET. LOSS (MIN)

0.5MHz-40MHz	-18 dB
40MHz-100MHz	-12+20LOG(f/80MHz) dB

CM TO CM REJ

100kHz - 100MHz	-30 dB MIN
-----------------	------------

CM TO DM REJ

100kHz - 100MHz	-35 dB MIN
-----------------	------------

HIPOT (Isolation Voltage):

1500 Vrms

LED

VF (FORWARD VOLTAGE)	IF=20mA	GREEN	2.2V TYP.
		PURE ORANGE	2.0V TYP.
λD (DOMINANT WAVELENGTH)	IF=20mA	GREEN	565nm TYP.
		PURE ORANGE	610nm TYP.

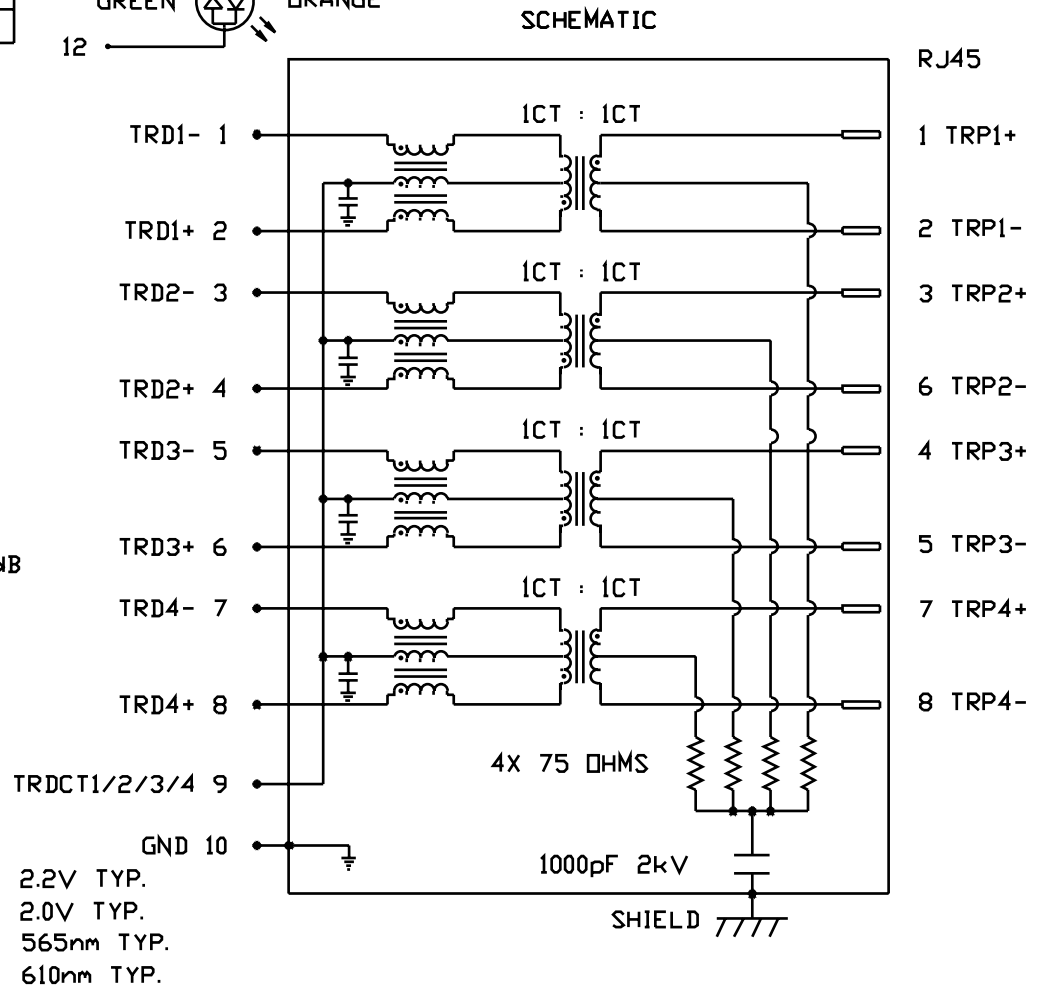

INTEGRATED CONNECTOR MODULES

0863-2X6R-54 Gigabit Ethernet MagJack® 2 x 6 with LEDs

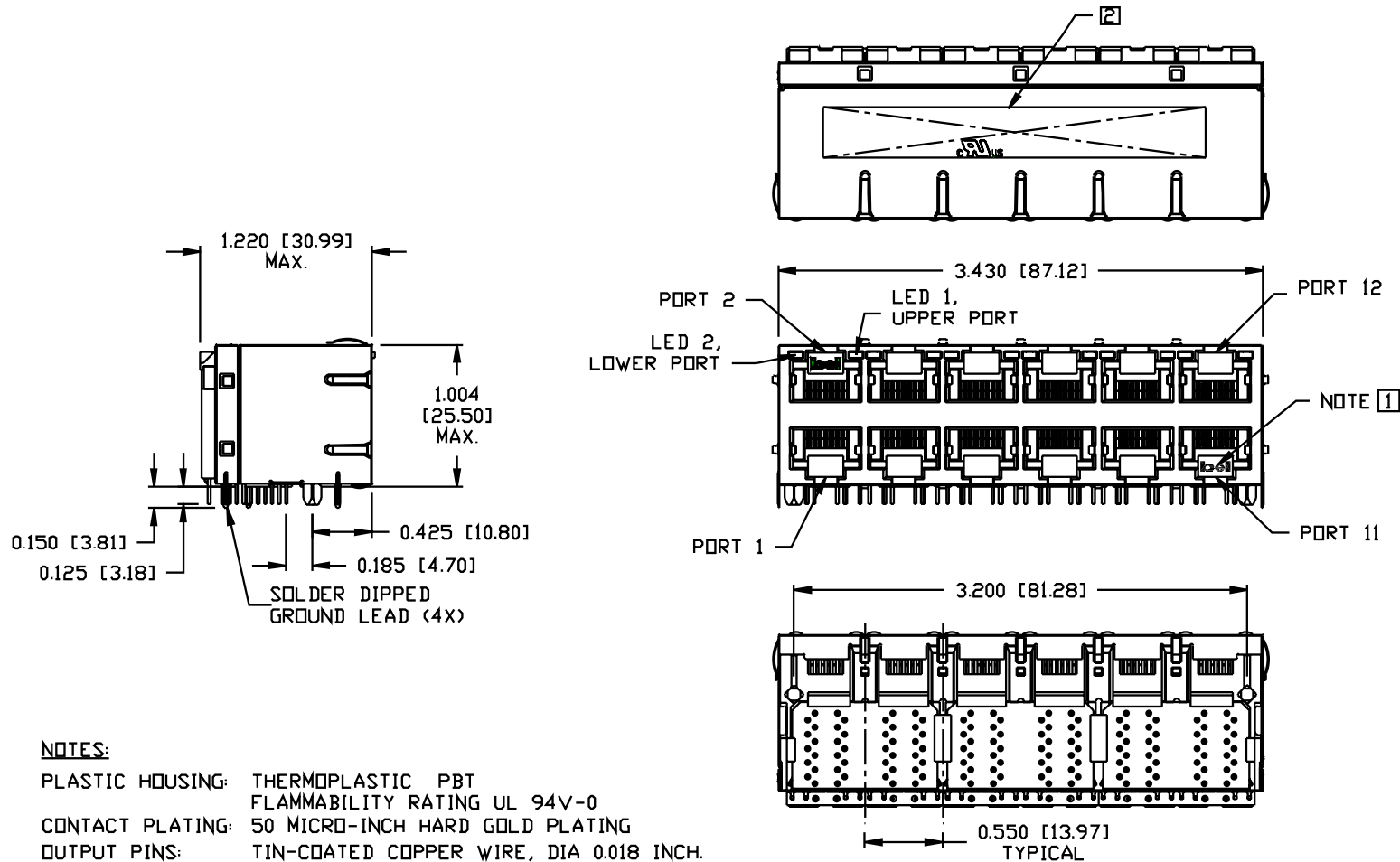

NOTES:

- PLASTIC HOUSING: THERMOPLASTIC PBT
FLAMMABILITY RATING UL 94V-0
- CONTACT PLATING: 50 MICRO-INCH HARD GOLD PLATING
- OUTPUT PINS: TIN-COATED COPPER WIRE, DIA 0.018 INCH.
- SOLDERABILITY: PER MIL STD. 202, METHOD 208.
- METAL SHIELD: NICKEL PLATED COPPER ALLOY.
(ALL GROUND LEADS ARE SOLDER DIPPED)

- [1] JACK CAVITY CONFORMS TO FCC RULES AND REGULATIONS, PART 68 SUBPART F.
 - [2] MARK PART WITH MFG LOGO, MFG NAME, PART NUMBER, AND DATE CODE.
- UL RECOGNIZED - FILE #E196366 AND E169987.

INTEGRATED CONNECTOR MODULES

0863-2X6R-54 Gigabit Ethernet MagJack® 2 x 6 with LEDs

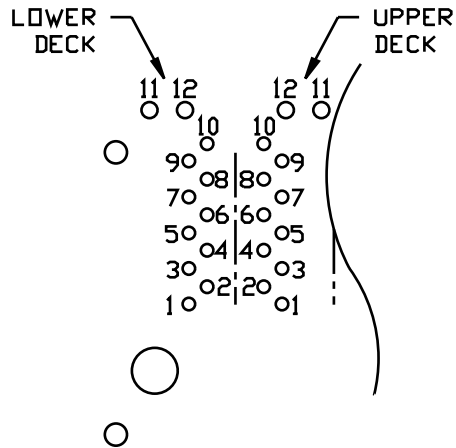

PIN-OUT INFORMATION
(COMPONENT SIDE VIEW)

12	GRN (+)/ORG (-)
11	GRN (-)/ORG (+)
10	GND
9	TRCT1/2/3/4
8	TRD 4+
7	TRD 4-
6	TRD 3+
5	TRD 3-
4	TRD 2+
3	TRD 2-
2	TRD 1+
1	TRD 1-

PORT ASSIGNMENT
(COMPONENT SIDE VIEW)

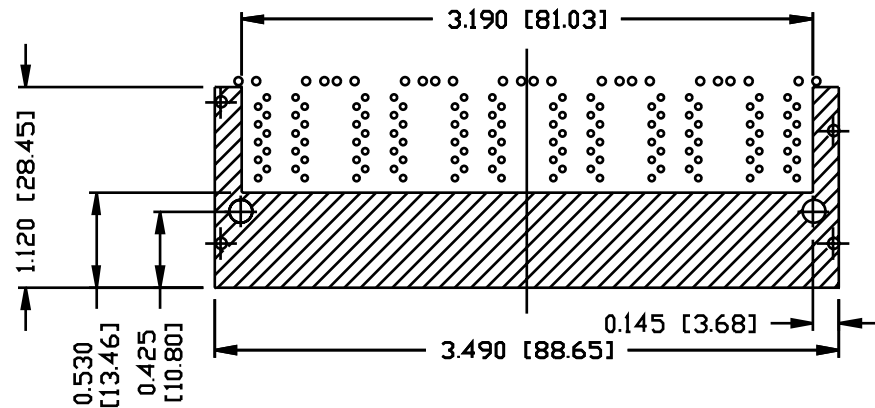
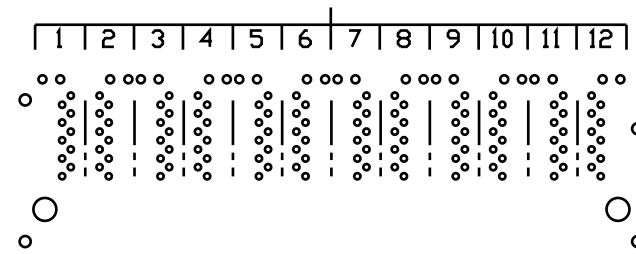

THE SHADED AREA OF BOTTOM SIDE OF PART
MAY BE COVERED BY METAL SHIELD.

INTEGRATED CONNECTOR MODULES

0863-2X6R-54 Gigabit Ethernet MagJack® 2 x 6 with LEDs

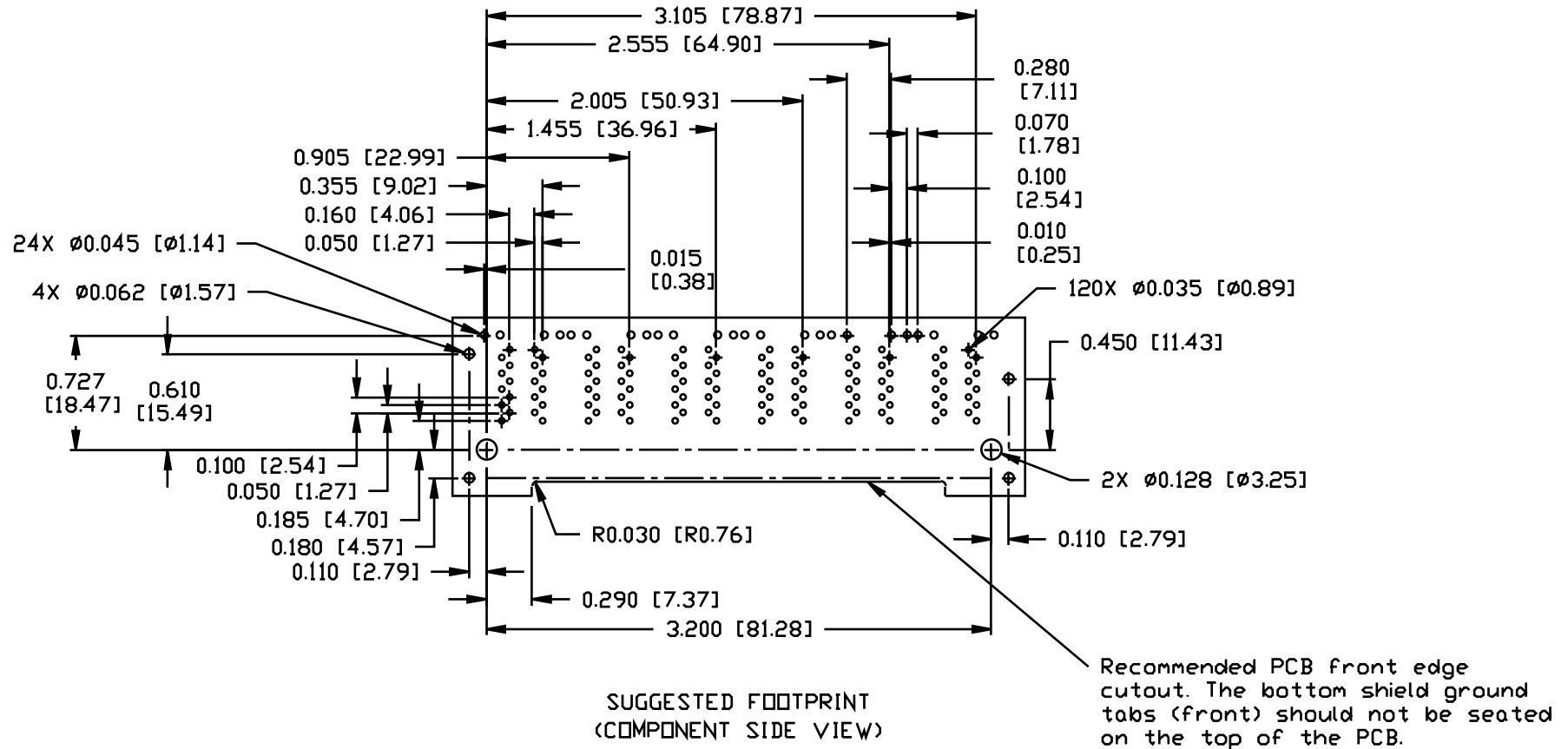

INTEGRATED CONNECTOR MODULES
0863-2X6R-54 Gigabit Ethernet MagJack® 2 x 6 with LEDs

SUGGESTED PANEL OPENING

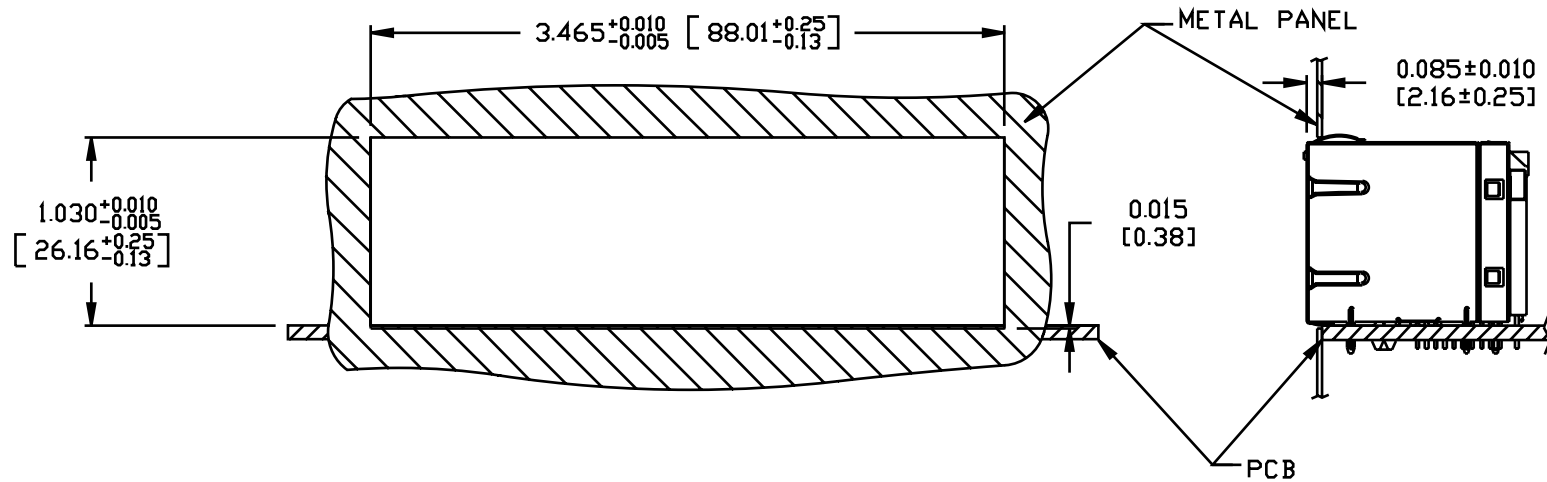

NOTES:

THE DISTANCE OF PANEL INSIDE SURFACE RELATIVE TO FRONT SURFACE OF PART IS ONLY A SUGGESTION. IN CASE THIS DISTANCE IS DIFFERENT, THE REQUIRED PANEL OPENING DIMENSIONS CHANGE ACCORDINGLY.

PACKING INFORMATION

PACKING TRAY : 0200-0148-40 (TOP)
 0200-0148-54 (BOTTOM)

PACKING QUANTITY : 15 PCS FINISHED GOODS PER TRAY
 7 TRAY (105 PCS FINISHED GOODS) PER CARTON BOX

NOTE : CARDBOARDS ARE PLACED BETWEEN LAYERS OF PACKING TRAY INSIDE CARTON BOX (INCLUDE THE UPPERMOST AND LOWERMOST TRAY)