



C8051F221

Mixed-Signal 8KB ISP FLASH MCU

PRELIMINARY

ANALOG PERIPHERALS

8-bit, 22-Channel ADC

- 22 External Inputs (Each Port I/O can be configured as an ADC Input on the Fly!)
- $\pm 1/2$ LSB INL
- No Missing Codes
- Programmable Throughput up to 100ksp/s

Two Comparators

- Programmable Hysteresis
- Configurable to Generate Interrupts or Reset

VDD Monitor and Brown-out Detector

ON-CHIP JTAG EMULATION

- On-Chip Emulation Circuitry Facilitates Full Speed, Non-Intrusive In-Circuit Emulation
- Supports Breakpoints, Single Stepping, Watchpoints
- Inspect/Modify Memory and Registers
- Superior Performance to Emulation Systems Using ICE-Chips, Target Pods, and Sockets
- \$99 Development Kit (C8051F226DK)

SUPPLY VOLTAGE 2.7V to 3.6V

- Typical Operating Current: 9mA @ 25MHz
- Multiple Power Saving Sleep and Shutdown Modes

8051-COMPATIBLE mC Core

- Pipelined Instruction Architecture; Executes 70% of Instructions in 1 or 2 System Clocks
- Up to **25MIPS** Throughput with 25MHz Clock
- Expanded Interrupt Handler; Up to 22 Interrupt Sources

MEMORY

- 256 Bytes Data RAM
- 8k Bytes FLASH; In-System Programmable in 512 byte Sectors

DIGITAL PERIPHERALS

- 22 Port I/O; All are 5V tolerant
- Hardware SPI™ and UART Serial Ports Available Concurrently
- Three 16-bit Counter/Timers
- Dedicated Watch-Dog Timer
- Bi-directional Reset

CLOCK SOURCES

- Internal Programmable Oscillator: 2-to-16MHz
- External Oscillator: Crystal, RC, C, or Clock
- Can Switch Between Clock Sources on-the-fly; Useful in Power Saving Modes

Temperature Range: -40°C to +85°C

32-Pin LQFP Package

SPI is a trademark of Motorola, Inc.

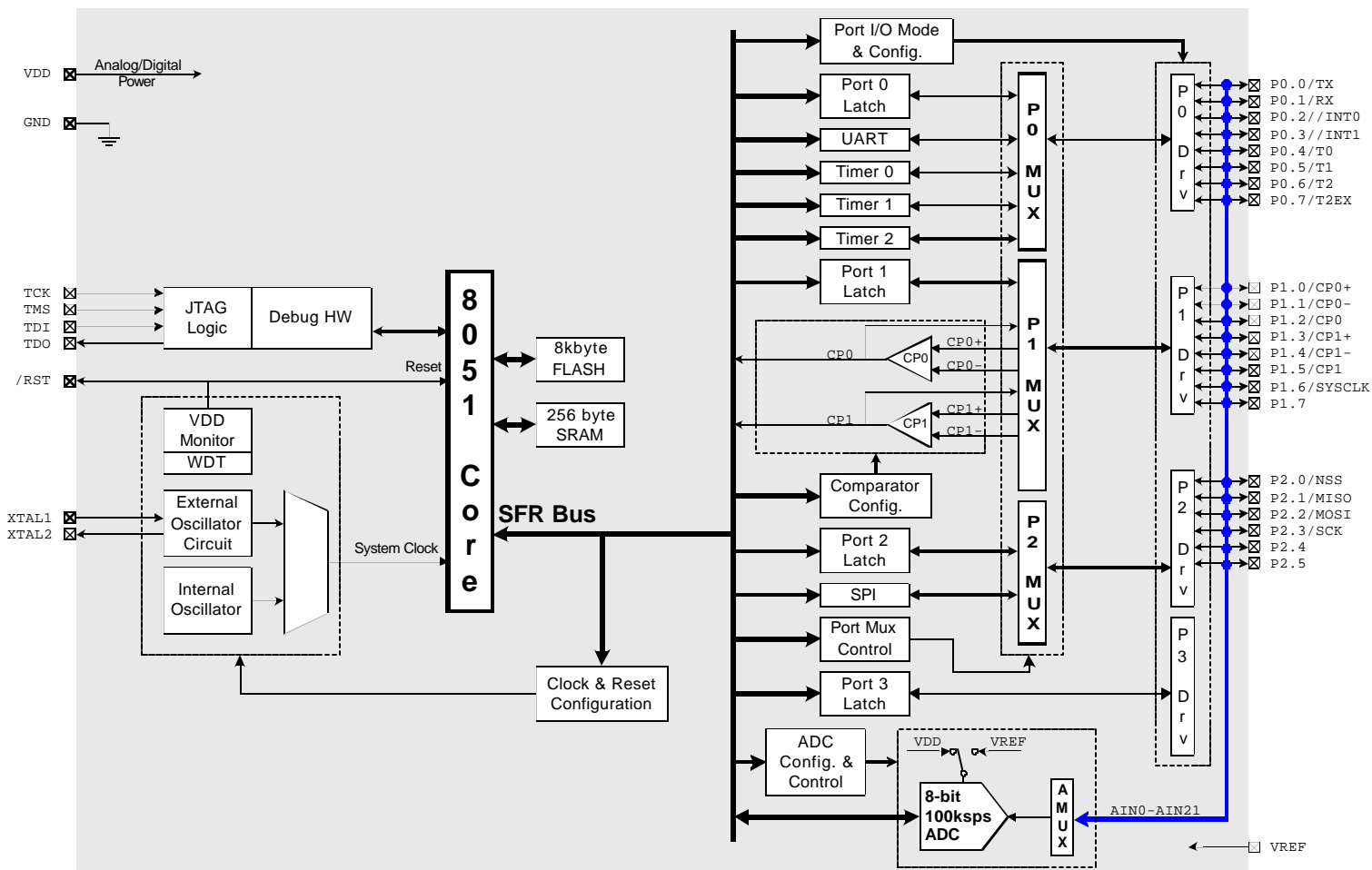



C8051F221

Mixed-Signal 8KB ISP FLASH MCU

PRELIMINARY

SELECTED ELECTRICAL SPECIFICATIONS TA = -40°C to +85°C unless otherwise specified.

PARAMETER	CONDITIONS	MIN	TYP	MAX	UNITS
GLOBAL CHARACTERISTICS					
Digital Supply Voltage		2.7		3.6	V
Digital Supply Current with CPU active	Clock=25MHz Clock=1MHz Clock=32kHz		9 0.4 18		mA mA μA
Digital Supply Current (shutdown)	Oscillator not running		7		μA
Digital Supply RAM Data Retention Voltage			1.5		V
CPU & DIGITAL I/O PORTS					
Clock Frequency Range		DC		25	MHz
Port Output High Voltage	I _{OH} = -3mA, Port I/O push-pull	VDD - 0.7			V
Port Output Low Voltage	I _{OL} = 8.5mA			0.6	V
Input High Voltage		0.8 x VDD			V
Input Low Voltage				0.2 x VDD	V
SPI Bus Clock Frequency	fCLK=MCU Clock; SPI in Master Mode			fCLK/2	MHz
A/D CONVERTER					
Resolution		8			bits
Integral Nonlinearity				±1/2	LSB
Differential Nonlinearity	Guaranteed Monotonic			±1/2	LSB
Signal to Noise Ratio			49		dB
Throughput Rate				100	ksps
Input Voltage Range		0		VREF	V
COMPARATORS					
Response Time	CP+ - CP- = 100mV		4		μs
Input Voltage Range		-0.25		VDD + 0.25	V
Input Bias Current		-5	0.001	+5	nA
Input Offset Voltage		-10		+10	mV

PACKAGE INFORMATION

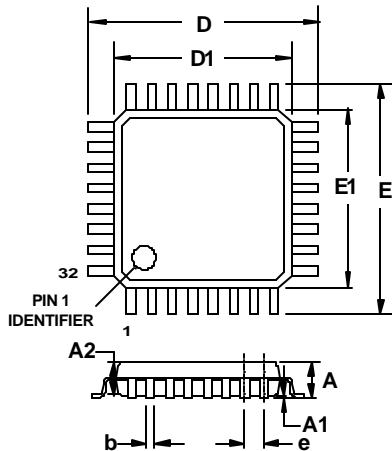

	MIN (mm)	NOM (mm)	MAX (mm)
A	-	-	1.60
A1	0.05	-	0.15
A2	1.35	1.40	1.45
b	0.30	0.37	0.45
D	-	9.00	-
D1	-	7.00	-
e	-	0.80	-
E	-	9.00	-
E1	-	7.00	-

C8051F226DK DEVELOPMENT KIT (\$99)

