

General Description

The AAT4618 SmartSwitch is a member of AnalogicTech's Application Specific Power MOSFET™ (ASPM™) product family. It is a current limited P-channel MOSFET power switch designed for high-side load switching applications operating with inputs ranging from 2.4V to 5.5V, making it ideal for 2.5V, 3V, and 5V systems. An integrated current-limiting circuit protects the input supply from large currents which may cause the supply to fall out of regulation. In addition, the AAT4618 thermal overload protection limits power dissipation and junction temperatures associated with prolonged periods of operation in current limit. Due to its low $R_{DS(ON)}$, the AAT4618 can be used to control loads that require up to factory preset 400mA, 500mA, or 1A. The ultra-fast current limit response to a sudden short circuit is a mere 400ns which reduces the requirements of local supply bypassing. An open drain FAULT flag signals an over-current or over-temperature condition after a 4ms timeout. Quiescent current is a low 10 μ A and the supply current decreases to less than 1 μ A in shutdown mode.

The AAT4618 is available in a Pb-free 5-pin SOT-23 or a 8-pin SC70JW package and is specified over the -40°C to +85°C temperature range.

The AAT4600 series is a family of adjustable and fixed voltage SmartSwitch products with a range of current handling capabilities. Single versions with adjustable current limit (AAT4610, AAT4601) or fixed current limit (AAT4625) are available, as well as dual versions with fixed current limit (AAT4626, AAT4670).

Features

- 2.4V to 5.5V Input Voltage Range
- Current Limit Trip Threshold Options:
 - 400mA Min
 - 500mA Min
 - 1A Min
- Fast Transient Response:
 - 400ns Response to Short Circuit
- Low Quiescent Current:
 - 10 μ A Typical
 - < 1 μ A with Switch Off
- 125m Ω Typical $R_{DS(ON)}$
- FAULT Flag with 4ms Blanking
- Under-Voltage Lockout
- Thermal Shutdown
- Temperature Range: -40°C to +85°C
- 4kV ESD Rating
- 5-Pin SOT23 or 8-Pin SC70JW Package

Applications

- Hot Swap Supplies
- Notebook Computers
- Peripheral Ports
- Personal Communication Devices
- USB Ports

Typical Application

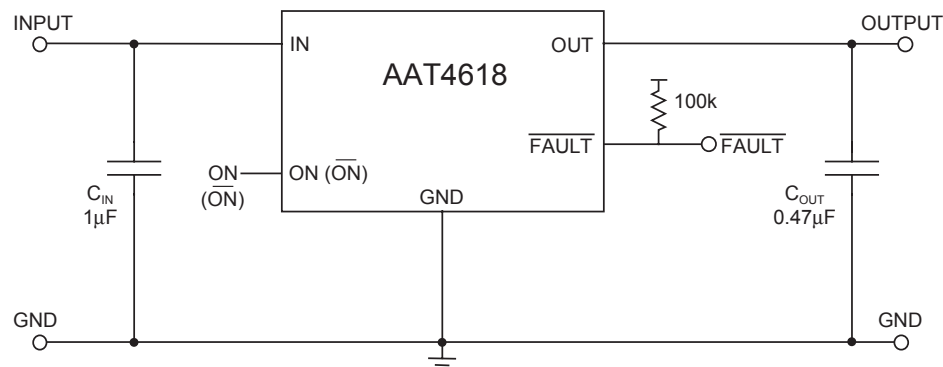

Pin Descriptions

Pin #		Symbol	Function
SOT23-5	SC70JW-8		
1	5	OUT	P-channel MOSFET drain.
2	6, 7, 8	GND	Ground connection.
3	1	$\overline{\text{FAULT}}$	Open-drain $\overline{\text{FAULT}}$ output.
4	2	ON ($\overline{\text{ON}}$)	Enable input: AAT4618 active low, AAT4618-1 active high.
5	3, 4	IN	P-channel MOSFET source.

Pin Configuration

SOT23-5
(Top View)

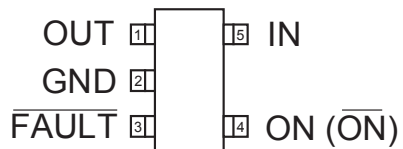

SC70JW-8
(Top View)

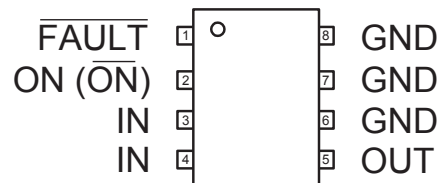

Absolute Maximum Ratings¹

$T_A = 25^\circ\text{C}$, unless otherwise noted.

Symbol	Description	Value	Units
$V_{IN, FAULT}$	IN, FAULT to GND	-0.3 to 6	V
V_{ON}	ON (\overline{ON}) to GND	-0.3 to $V_{IN} + 1$	V
V_{OUT}	OUT to GND	-0.3 to $V_{IN} + 0.3$	V
I_{OUT}	Output Current	Internally Limited	A
T_J	Operating Junction Temperature Range	-40 to 150	$^\circ\text{C}$
V_{ESD}	ESD Rating ² —HBM	4000	V
T_{LEAD}	Maximum Soldering Temperature (at Leads)	300	$^\circ\text{C}$

Thermal Characteristics³

Symbol	Description	Value	Units
Θ_{JA}	Maximum Thermal Resistance	150	$^\circ\text{C}/\text{W}$
P_D	Maximum Power Dissipation	667	mW

1. Stresses above those listed in Absolute Maximum Ratings may cause permanent damage to the device. Functional operation at conditions other than the operating conditions specified is not implied. Only one Absolute Maximum Rating should be applied at any one time.
2. Human body model is a 100pF capacitor discharged through a 1.5k Ω resistor into each pin.
3. Mounted on a demo board.

Electrical Characteristics

$V_{IN} = 5V$, $T_A = -40^{\circ}C$ to $+85^{\circ}C$, unless otherwise noted. Typical values are $T_A = 25^{\circ}C$; **bold** values denote full temperature range.

Symbol	Description	Conditions	Min	Typ	Max	Units	
V_{IN}	Operation Voltage		2.4		5.5	V	
I_Q	Quiescent Current	$V_{IN} = 5V$, ON (ON) = Active, $I_{OUT} = 0$		10	25	μA	
$I_{Q(OFF)}$	Off Supply Current	ON (\overline{ON}) = Inactive, $V_{IN} = 5.5V$			1	μA	
$I_{SD(OFF)}$	Off Switch Current	ON (\overline{ON}) = Inactive, $V_{IN} = 5.5V$, $V_{OUT} = 0$		0.1	1	μA	
V_{UVLO}	Under-Voltage Lockout	V_{IN} Falling		1.9		V	
$V_{UVLO(hys)}$	Under-Voltage Lockout Hysteresis			0.3		V	
$R_{DS(ON)}$	On Resistance	$V_{IN} = 5.0V$, $T_A = 25^{\circ}C$		125	175	$m\Omega$	
		$V_{IN} = 3.0V$, $T_A = 25^{\circ}C$		155	225		
TC_{RDS}	On Resistance Temperature Coefficient			2800		ppm/ $^{\circ}C$	
I_{LIM}	Current Limit	$V_{OUT} = V_{IN}$ to 0.5V	AAT4618-0.4	400	500	600	mA
			AAT4618-0.5	500	750	1000	
			AAT4618-1.0	1000	1500	2000	
$V_{ON(L)}$	ON (\overline{ON}) Input Low Voltage	$V_{IN} = 2.7V$ to $5.5V^1$			0.8	V	
$V_{ON(H)}$	ON (\overline{ON}) Input High Voltage	$V_{IN} = 2.7V$ to $\leq 4.2V^1$	2.0			V	
		$V_{IN} = > 4.2V$ to $5.0V^1$	2.4			V	
$I_{ON(SINK)}$	ON (\overline{ON}) Input Leakage	$V_{ON(\overline{ON})} = 5.5V$		0.01	1	μA	
t_{RESP}	Current Loop Response	$V_{IN} = 5V$		400		ns	
T_{OFF}	Turn-Off Time	$V_{IN} = 5V$, $R_L = 20\Omega$		5		μs	
T_{ON}	Turn-On Time	$V_{IN} = 5V$, $R_L = 20\Omega$		1		μs	
$V_{FAULTLOW}$	\overline{FAULT} Logic Output Low	$I_{SINK} = 1mA$			0.4	V	
I_{SINK}	\overline{FAULT} Logic Output High Leakage Current	$V_{FAULT} = 5.5V$		0.5	1	μA	
T_{blank}	Fault Blanking Time			4		ms	
T_{SD}	Over-Temperature Threshold	$V_{IN} = 5V$		125		$^{\circ}C$	

1. For V_{IN} outside this range, consult Typical ON (\overline{ON}) Threshold curve.

Typical Characteristics

Unless otherwise noted, $V_{IN} = 5V$, $T_A = 25^\circ C$.

Quiescent Current vs. Temperature

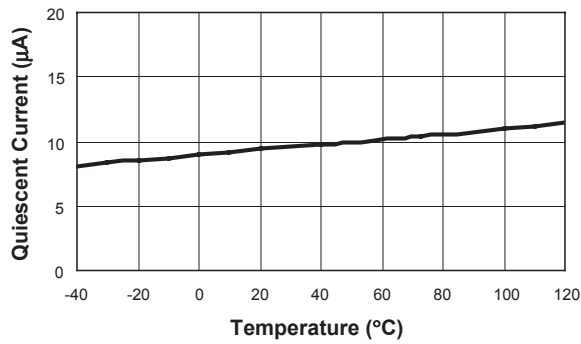

Quiescent Current vs. Input Voltage

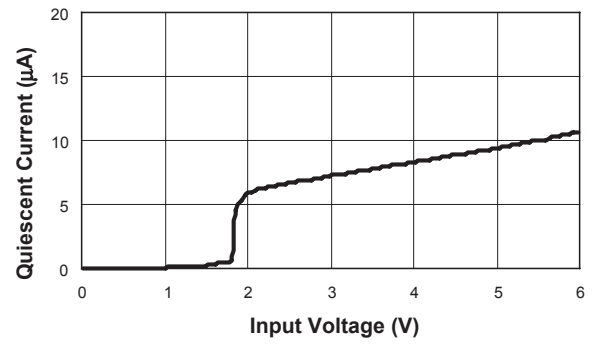

Normalized Current Limit vs. Output Voltage

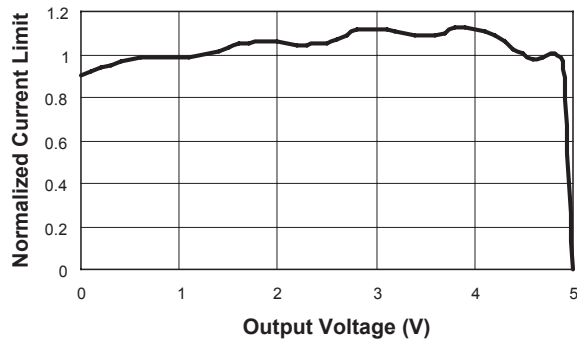

$R_{DS(ON)}$ vs. Temperature

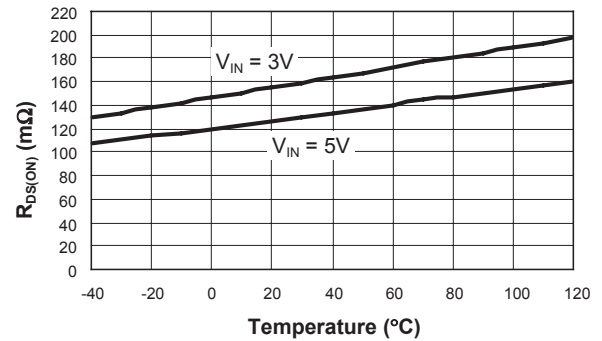

Off-Supply Current vs. Temperature

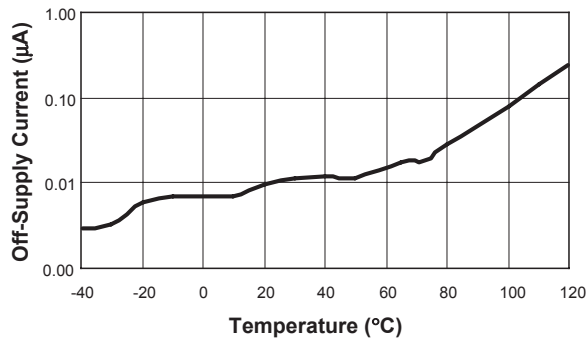

Off-Switch Current vs. Temperature

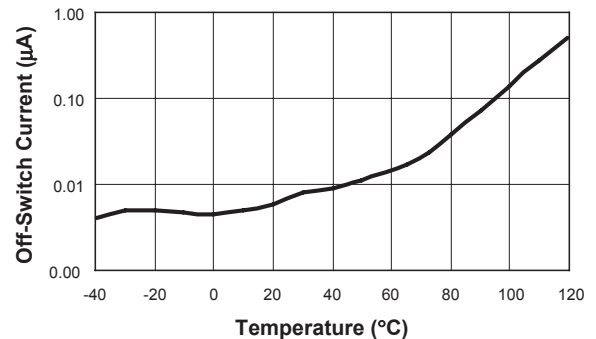

Typical Characteristics

Unless otherwise noted, $V_{IN} = 5V$, $T_A = 25^\circ C$.

Turn-On
($R_L = 20\Omega$; $C_L = 0.47\mu F$)

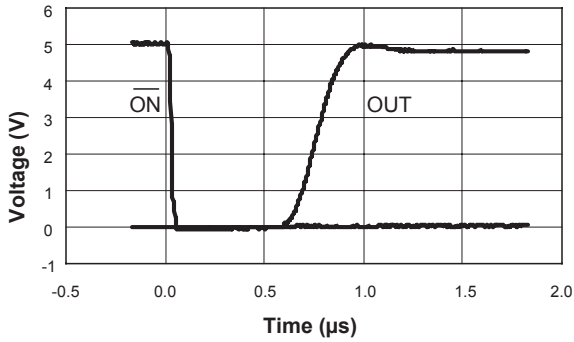

Turn-Off
($R_L = 20\Omega$; $C_L = 0.47\mu F$)

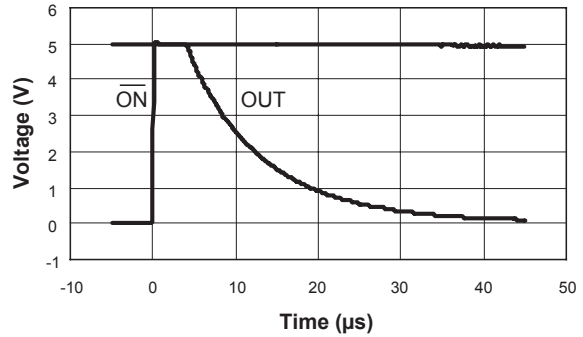

Short Circuit Through 0.3Ω

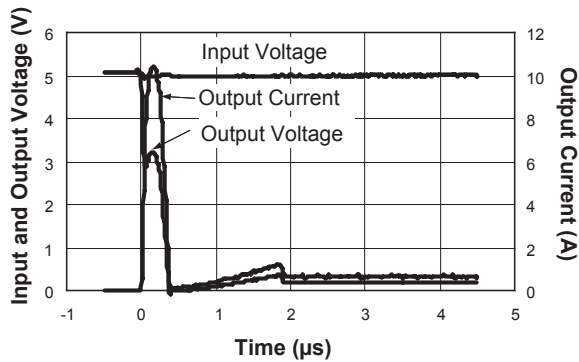

Thermal Shutdown Response

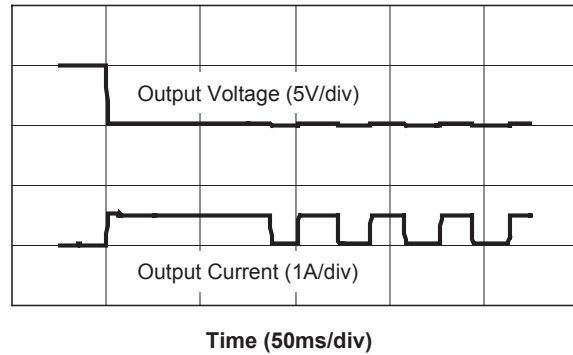

Fault Delay from Short Circuit

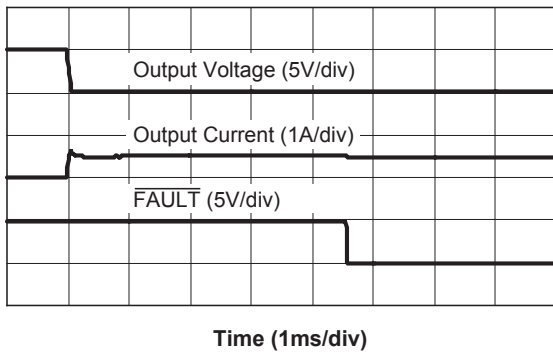

ON (\overline{ON}) Threshold vs. Input Voltage

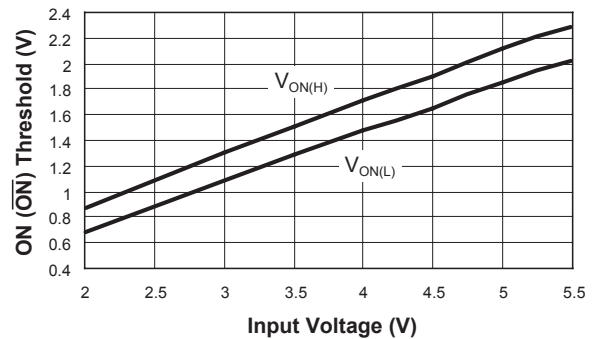

Functional Block Diagram

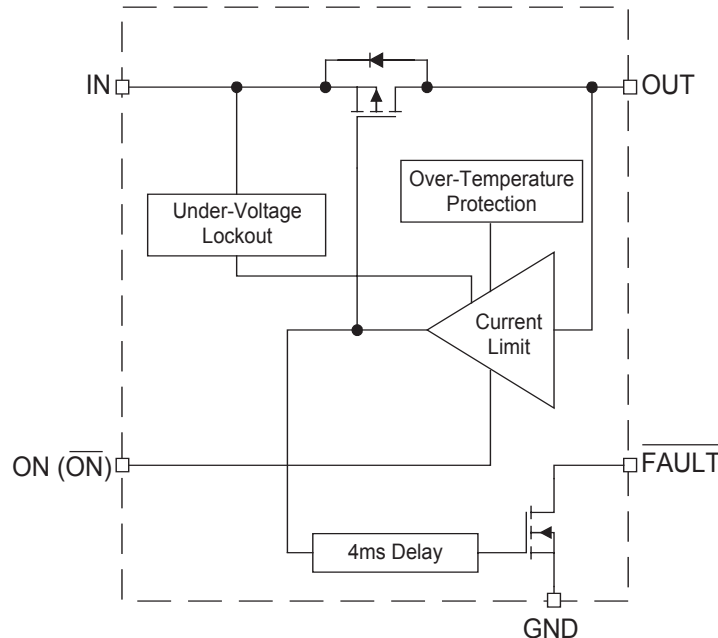

Functional Description

The AAT4618 is a single channel current limited load switch that protects against short circuits by current limiting to a preset level. A patented fast-acting current limit loop limits the current in a fraction of a microsecond and instantly resets to low impedance once the short-circuit condition is removed. The AAT4618 is internally protected from thermal damage by an over-temperature detection circuit. If the die temperature reaches the internal thermal limit, the power device is switched off until the die temperature cools to a level below the thermal limit threshold. The device will thermal cycle indefinitely until the over-current condition is removed. The AAT4618 operates with

input voltages ranging from 2.4V to 5.5V which, along with its extremely low operating current, makes it ideal for battery-powered applications. In cases where the input voltage drops below 2.4V, the AAT4618 MOSFET is protected from entering the saturated region of operation by being automatically shut down by an under-voltage lockout circuit. A current limit condition is reported by the open drain FAULT output. A 4ms blanking interval prevents false reporting during the charging of a capacitive load, which typically occurs during device turn-on, but may also occur during a port hot plug-in event.

The AAT4618 is ideally suited for protection of peripheral ports such as USB, RS232, and parallel ports.

Applications Information

Input Capacitor

The input capacitor C_{IN} protects the power supply from current transients generated by the load attached to the AAT4618. When a short circuit is suddenly applied to the output of the AAT4618, a large current, limited only by the $R_{DS(ON)}$ of the MOSFET, will flow for less than 1 μ s before the current limit circuitry activates. (See characteristic curve "Short Circuit Through 0.3 Ω .") In this event, a moderately sized C_{IN} will dramatically reduce the voltage transient seen by the power supply and by other circuitry upstream from the AAT4618. The extremely fast short-circuit response time of the AAT4618 reduces the size requirement of C_{IN} .

C_{IN} should be located as close to the device VIN pin as practically possible. Ceramic, tantalum, or aluminum electrolytic capacitors are appropriate for C_{IN} . There is no specific capacitor ESR requirement for C_{IN} . However, for higher current operation, ceramic capacitors are recommended for C_{IN} due to their inherent capability over tantalum capacitors to withstand input current surges from low impedance sources such as batteries in portable devices.

Output Capacitor

In order to insure stability while current limit is active, a low capacitance (approximately 0.47 μ F) is required. No matter how large the output capacitor, output current is limited to the value set by the AAT4618 current limiting circuitry, so very large output capacitors can be used.

For example, USB ports are specified to have at least 120 μ F of capacitance downstream from their controlling power switch. The current limiting circuit will allow an output capacitance of 1000 μ F or more without disturbing the upstream power supply.

ON (Enable Input)

In many systems, power planes are controlled by integrated circuits which run at lower voltages than the power plane itself. The enable input (ON) of the AAT4618 has low and high threshold voltages that accommodate this condition. The threshold voltages are compatible with 5V TTL and 2.5V to 5V CMOS systems.

When switching the AAT4618 on into a capacitive load, the AAT4618 will charge the output capacitive load at a rate no greater than the current limit setting.

Attaching Loads

Capacitive loads attached to an enabled AAT4618 will charge at a rate no greater than the current limit setting.

FAULT Output

The FAULT flag is provided to alert the system if an AAT4618 load is not receiving sufficient voltage to operate properly. If current limit or over-temperature circuits in any combination are active for more than approximately 4ms, the FAULT flag is pulled to ground through approximately 100 Ω . The filtering of voltage or current transients of less than 4ms prevents capacitive loads connected to the AAT4618 output from activating the FAULT flag when they are initially attached. Pull-up resistances of 1k Ω to 100k Ω are recommended. Since FAULT is an open drain terminal, it may be pulled up to any unrelated voltage less than the maximum operating voltage of 5.5V, allowing for level shifting between circuits.

Thermal Considerations

Since the AAT4618 has internal current limit and over-temperature protection, junction temperature is rarely a concern. However, if the application requires large currents in a hot environment, it is possible that temperature, rather than current limit, will be the dominant regulating condition. In these applications, the maximum current available without risk of an over-temperature condition must be calculated. The maximum internal temperature while current limit is not active can be calculated using Equation 1.

$$\text{Eq. 1: } T_{J(MAX)} = I_{MAX}^2 \cdot R_{DS(ON)(MAX)} \cdot R_{\theta JA} + T_{A(MAX)}$$

In Equation 1, I_{MAX} is the maximum current required by the load. $R_{DS(ON)(MAX)}$ is the maximum rated $R_{DS(ON)}$ of the AAT4618 at high temperature. $R_{\theta JA}$ is the thermal resistance between the AAT4618 die and the board onto which it is mounted. $T_{A(MAX)}$ is the maximum temperature that the PCB under the

AAT4618 would be if the AAT4618 were not dissipating power. Equation 1 can be rearranged to solve for I_{MAX} , as shown in Equation 2.

$$\text{Eq. 2: } I_{MAX} = \sqrt{\frac{T_{SD(MIN)} - T_{A(MAX)}}{R_{DS(ON)(MAX)} \cdot R_{\theta JA}}}$$

$T_{SD(MIN)}$ is the minimum temperature required to activate the AAT4618 over-temperature protection. With the typical specification of 125°C, 115°C is a safe minimum value to use.

For example, if an application is specified to operate in 50°C environments, the PCB operates at temperatures as high as 85°C. The application is sealed and its PCB is small, causing $R_{\theta JA}$ to be approximately 150 °C/W. Using Equation 2,

$$\text{Eq. 3: } I_{MAX} = \sqrt{\frac{115 - 85}{220 \cdot 150}} = 950\text{mA}$$

The AAT4618 is safe to operate at the minimum current limit level of 500mA at 85°C.

Ordering Information

Package	Enable	Current Limit	Marking ¹	Part Number (Tape and Reel) ²
SOT23-5	Active Low	0.5	AVXYY	AAT4618IGV-0.5-T1
SOT23-5	Active High	0.5	DWXY	AAT4618IGV-0.5-1-T1
SOT23-5	Active Low	1.0	EVXYY	AAT4618IGV-1.0-T1
SOT23-5	Active High	1.0	EIXYY	AAT4618IGV-1.0-1-T1
SC70JW-8	Active Low	0.4		
SC70JW-8	Active High	0.4		
SC70JW-8	Active Low	0.5	AVXYY	AAT4618IJS-0.5-T1
SC70JW-8	Active High	0.5	DWXY	AAT4618IJS-0.5-1-T1
SC70JW-8	Active Low	1.0	EVXYY	AAT4618IJS-1.0-T1
SC70JW-8	Active High	1.0	EIXYY	AAT4618IJS-1.0-1-T1



All AnalogicTech products are offered in Pb-free packaging. The term “Pb-free” means semiconductor products that are in compliance with current RoHS standards, including the requirement that lead not exceed 0.1% by weight in homogeneous materials. For more information, please visit our website at <http://www.analogictech.com/pbfree>.

Package Information

SOT23-5

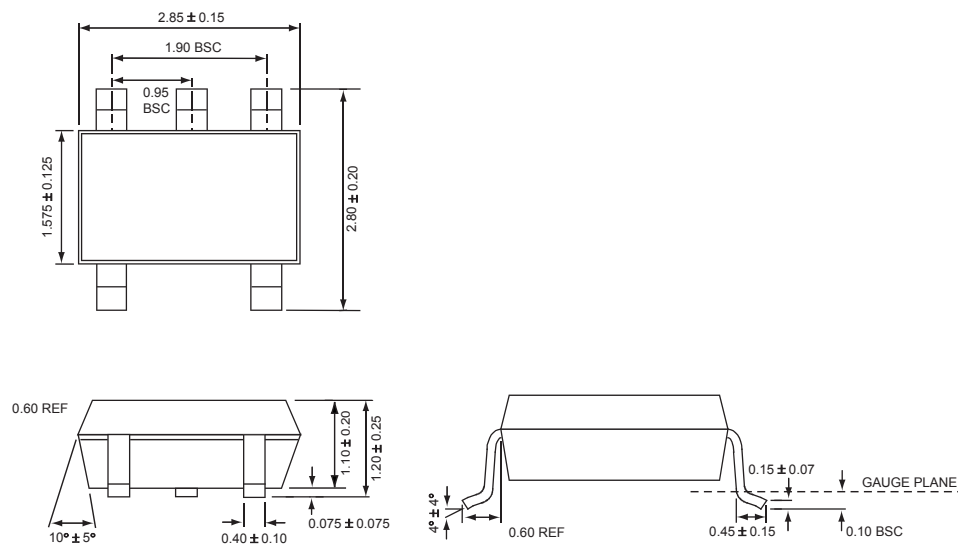

All dimensions in millimeters

1. XYY = assembly and date code.
2. Sample stock is generally held on all part numbers listed in **BOLD**.

SC70JW-8

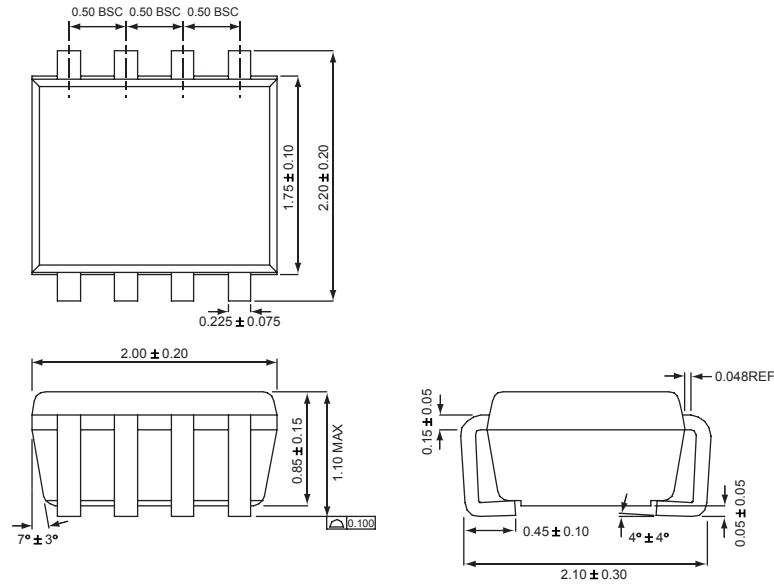

All dimensions in millimeters.

© Advanced Analogic Technologies, Inc.

AnalogicTech cannot assume responsibility for use of any circuitry other than circuitry entirely embodied in an AnalogicTech product. No circuit patent licenses, copyrights, mask work rights, or other intellectual property rights are implied. AnalogicTech reserves the right to make changes to their products or specifications or to discontinue any product or service without notice. Customers are advised to obtain the latest version of relevant information to verify, before placing orders, that information being relied on is current and complete. All products are sold subject to the terms and conditions of sale supplied at the time of order acknowledgement, including those pertaining to warranty, patent infringement, and limitation of liability. AnalogicTech warrants performance of its semiconductor products to the specifications applicable at the time of sale in accordance with AnalogicTech's standard warranty. Testing and other quality control techniques are utilized to the extent AnalogicTech deems necessary to support this warranty. Specific testing of all parameters of each device is not necessarily performed.

AnalogicTech and the AnalogicTech logo are trademarks of Advanced Analogic Technologies Incorporated. All other brand and product names appearing in this document are registered trademarks or trademarks of their respective holders.

Advanced Analogic Technologies, Inc.
 830 E. Arques Avenue, Sunnyvale, CA 94085
 Phone (408) 737-4600
 Fax (408) 737-4611