

Features

- 4:1 multiplexer with monitor out
- 18dB variable gain amplifier
- DC-restore amplifier
- Digital control serial interface
- $\pm 5V$ operation
- 500MHz bandwidth

Applications

- HDTV/DTV Analog Inputs
- Video Projectors
- Computer Monitors
- Set Top Boxes
- Security Video
- Broadcast Video Equipment

Ordering Information

Part No.	Package	Tape & Reel	Outline #
EL4102CU	24-Pin QSOP		MDP0040

General Description

The EL4102C VFE (Video Front End) is designed to perform all of the input processing functions in an analog video system as well as provide analog input processing for digital video systems. The EL4102C VFE contains a 4:1 MUX input, a DC-restore amplifier and a variable gain amplifier. The MUX input can be used to select which input to use. In a digital system, the DC-restore and variable gain amplifiers allow the input signal to be positioned and scaled to give optimum A-to-D conversions results. In an analog system these perform the brightness and contrast operations. A buffered output of the MUX selection is also available for use as a monitor output.

With a 500MHz bandwidth and only 50mA supply current, the EL4102C is ideal for use in portable and fixed projectors, as well as HDTV, DTV and other high performance video applications.

A 3-wire digital interface enables full control of the input selection, as well as 0 to -18dB of gain and blanking operations.

The EL4102C is available in the QSOP24 package and is specified for operation over the $-40^{\circ}C$ to $+85^{\circ}C$ temperature range.

Connection Diagram

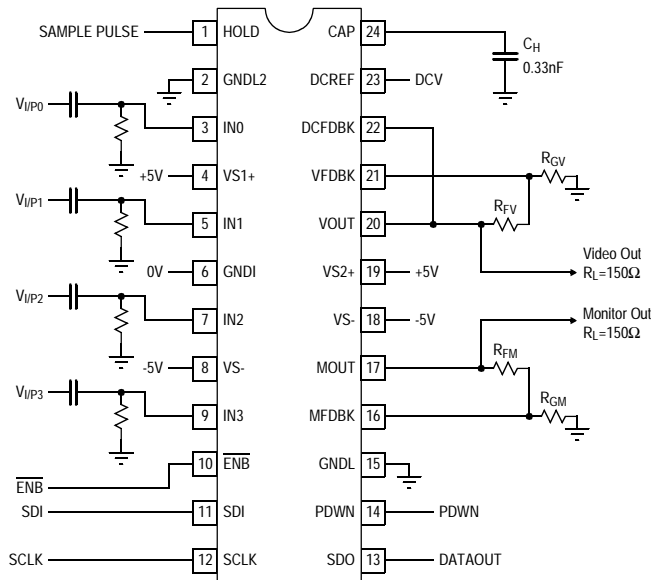

Note: All information contained in this data sheet has been carefully checked and is believed to be accurate as of the date of publication; however, this data sheet cannot be a "controlled document". Current revisions, if any, to these specifications are maintained at the factory and are available upon your request. We recommend checking the revision level before finalization of your design documentation.

EL4102C - Preliminary

500MHz Video Front End: 4-1 MUX, VGA & DC-Restore

Absolute Maximum Ratings (T_A = 25°C)

Values beyond absolute maximum ratings can cause the device to be prematurely damaged. Absolute maximum ratings are stress ratings only and functional device operation is not implied.

Supply Voltage (V_{S+} to V_{S-}) 11V
 Input Voltage V_{S-} - 0.3V, V_{S+} +0.3V

Storage Temperature Range -65°C to +150°C
 Ambient operating Temperature -40°C to +85°C
 Operating Junction Temperature 125°C
 Power Dissipation See Curves

Important Note:

All parameters having Min/Max specifications are guaranteed. Typ values are for information purposes only. Unless otherwise noted, all tests are at the specified temperature and are pulsed tests, therefore: T_J = T_C = T_A.

Electrical Characteristics

V_{S1+} = V_{S2+} = 5V, V_{S1-} = V_{S2-} = -5V, R_{FV} = R_{FG} = 750, R_{GV} = R_{GM} = O.C., A_V = 1, R_LV = R_{LM} = 150Ω, C_{LV} = C_{LM} = 3p, C_H = 0.33n, GAIN = 1.

Parameter	Description	Conditions	Min	Typ	Max	Unit
Supply						
I _{S1+}	Positive Supply Current 1			35		mA
I _{S-}	Negative Supply Current	V _{IN} = 0, I _L = 0		45		mA
I _{S2+}	Positive Supply Current 2	V _{IN} = 0, I _L = 0	14	15	20	mA
I _{S1S+}	Positive Supply Current 1 in Standby	Standby	3.8	5	7.3	mA
I _{SS-}	Negative Supply Current in Standby	Standby	0.57	1	1.3	mA
I _{S2S+}	Positive Supply Current 2 in Standby	Standby	-10	-	10	μA
V _{S1+} , V _{S2+}	Positive Supply Voltage		4.5	5.0	5.5	V
V _{S-}	Negative Supply Voltage		-4.5	-5.0	-5.5	V
Input						
I _b	Input Bias Current	V _{IN} = 0V	-22.4	-2.2	6.1	μA
I _{bo}	Input Bias Current Drift with Temp.	V _{IN} = 0V		TBD		nA/°C
V _{IH}	Input High Voltage		2			V
V _{IL}	Input Low Voltage				0.8	V
V _{IP}	Input Voltage Swing, Pos.	Saturated Input, Att. code = 01010	3.35	3.5		V
V _{IN}	Input Voltage Swing, Neg.	Saturated Input, Att. code = 01010		-3.5	-3.39	V
I _{IDL}	Low Input Current for SCLK and $\overline{\text{ENB}}$	V _{IN} = 0V	50	85	150	μA
I _{IDH}	High Input Current for SCLK and $\overline{\text{ENB}}$	V _{IN} = 5V	0	0.1	10	μA
I _{IL}	Low Input Current for SDI, PDWN, HOLD	V _{IN} = 0V	15	48	75	μA
I _{IH}	High Input Current for SDI, PDWN, HOLD	V _{IN} = 5V	0	0.1	10	μA
t _{sh}	Sample and Hold Delay Time			15		ns
t _{su}	Data Set Up Time		TBD	10	TBD	ns
t _h	Data Hold Time		TBD	10	TBD	ns
f _{clk}	Serial Clock Rate			TBD	5	MHz
t _{se}	Enable Set Up Time		TBD	10		ns
t _{he}	Enable Hold Time		TBD	10		ns
t _{pd}	Clock to Data Output Delay	C _L = 10pF	TBD	21		ns
Output						
V _{OSM}	Output Offset Voltage - Monitor	V _{IN} = 0V	-400	30	420	mV
V _{OS}	DC-restore Offset Voltage	auto-zero on, DC _{REF} = 0	-5	-	5	mV
T _C V _{OS}	Output Offset Voltage Drift - Video	auto-zero on		15		μV/°C
V _{O+}	Output Voltage Swing, Pos.	Attenuator = 0dB, Monitor & Video Outputs	3.44	3.5		V
V _{O-}	Output Voltage Swing, Neg.	Attenuator = 0dB, Monitor & Video Outputs		-3.5	-3.43	V
V _S DO high	Serial Data Output High	I _L = +1mA		4.7		V
V _S DO low	Serial Data Output Low	I _L = -1mA		0.25		V

EL4102C - Preliminary

500MHz Video Front End: 4-1 MUX, VGA & DC-Restore

Electrical Characteristics

$V_{S1+} = V_{S2+} = 5V$, $V_{S1-} = V_{S2-} = -5V$, $R_{FV} = R_{FG} = 750$, $R_{GV} = R_{GM} = O.C.$, $A_V = 1$, $R_LV = R_{LM} = 150\Omega$, $C_{LV} = C_{LM} = 3p$, $C_H = 0.33n$, $GAIN = 1$.

Parameter	Description	Conditions	Min	Typ	Max	Unit
I _{sc}	Output Short Circuit Current	R _L = 10 Ω , Source or Sink	65	100		mA
AC Performance						
SR	Slew Rate - Video Out (20%-80%)	V _{OUT} = 4V _{P-P}	1000	2100	4500	V/ μ S
SRM	Slew Rate - Monitor Out (20%-80%)	V _{OUT} = 4V _{P-P}	1250	2100	3900	V/ μ S
OS	Output Overshoot, Video	V _{OUT} = 1V _{P-P}		TBD		%
OSM	Output Overshoot, Monitor	V _{OUT} = 1V _{P-P}		TBD		%
t _s	Settling Time to 1%, Video	Hold Mode		TBD		ns
t _{sm}	Settling Time to 1%, Monitor			TBD		ns
V _{REF}	DC-restore Reference Voltage Range	V _{IN} = -2V to +2V	-2	-	2	V
t _{sd}	DC-restore - Settling Time to 1%	Sample Mode On		1.2		μ S
V _{OHS}	DC-restore - Video Output Hold Step	S - H Transition		-1.1		mV
V _{OSB}	DC-restore - Offset vs. Black Level	Sample Mode On	-1	-0.6	1	mV/V
I _{CCL}	DC-restore - Charge Current Limit, I _{CAP}	Sample Mode On		260		μ A
I _{DC}	DC-restore - Droop Current, I _{CAP}	Hold Mode On	-30	-	30	nA
BW	3dB Bandwidth, Video Out	Attenuator = 00000		TBD		MHz
BWM	3dB Bandwidth, Monitor Out			TBD		MHz
0.1BW	± 0.1 dB Flat Bandwidth, Video Out	Attenuator = 00000		TBD		MHz
0.1BWM	± 0.1 dB Flat Bandwidth, Monitor Out			TBD		MHz
V _p	Peaking, Video			TBD		dB
V _{pm}	Peaking, Monitor			TBD		dB
dP	Diff. Phase @3.58MHz, Video			TBD		$^{\circ}$
dG	Diff. Gain @3.58MHz, Video			TBD		%
dPM	Diff. Phase @3.58MHz, Monitor			TBD		$^{\circ}$
dPG	Diff. Gain @3.58MHz, Monitor			TBD		%
e _n	Noise Voltage at Input for V _{OUT}			TBD		nV/ \sqrt Hz
e _{nm}	Noise Voltage at Input for M _{OUT}			TBD		nV/ \sqrt Hz
	Crosstalk ^[1] @10MHz	3 channel hostile		-45		dB
	Crosstalk ^[1] @100MHz	3 channel hostile		-20		dB
	Attenuator Range		-	18.2	-	dB
	Attenuator Step Size	31 Steps	-	0.58	-	dB
	Relative Attenuation Error	Between any 2 levels	0	-	± 0.2	dB

1. Total unwanted output normalized by wanted (or expected) output; add -10dB to get channel-to-channel isolation

EL4102C - Preliminary

500MHz Video Front End: 4-1 MUX, VGA & DC-Restore

Serial Programming Truth Table

Standby MSB	Inputs (X = Don't Care)						Input Selection		Attenuation
	Attenuation						Input Selection		
	B7	B6	B5	B4	B3	B2	B1	B0	
0	0	0	0	0	0	X	X	0dB = 1.000	
0	0	0	0	0	1	X	X	-0.6dB = 0.94	
0	0	0	0	1	0	X	X	-1.2dB = 0.88	
0	0	0	0	1	1	X	X	-1.7dB = 0.82	
0	0	0	1	0	0	X	X	-2.3dB = 0.77	
0	0	0	1	0	1	X	X	-2.9dB = 0.7	
0	0	0	1	1	0	X	X	-3.5dB = 0.67	
0	0	0	1	1	1	X	X	-4.1dB = 0.63	
0	0	1	0	0	0	X	X	-4.6dB = 0.59	
0	0	1	0	0	1	X	X	-5.2dB = 0.55	
0	0	1	0	1	0	X	X	-5.8dB = 0.51	
0	0	1	0	1	1	X	X	-6.4dB = 0.48	
0	0	1	1	0	0	X	X	-7.0dB = 0.45	
0	0	1	1	0	1	X	X	-7.5dB = 0.42	
0	0	1	1	1	0	X	X	-8.1dB = 0.39	
0	0	1	1	1	1	X	X	-8.7dB = 0.37	
0	1	0	0	0	0	X	X	-9.3dB = 0.34	
0	1	0	0	0	1	X	X	-9.9dB = 0.32	
0	1	0	0	1	0	X	X	-10.5dB = 0.30	
0	1	0	0	1	1	X	X	-11.0dB = 0.28	
0	1	0	1	0	0	X	X	-11.6dB = 0.26	
0	1	0	1	0	1	X	X	-12.2dB = 0.25	
0	1	0	1	1	0	X	X	-12.8dB = 0.23	
0	1	0	1	1	1	X	X	-13.4dB = 0.22	
0	1	1	0	0	0	X	X	-13.9dB = 0.20	
0	1	1	0	0	1	X	X	-14.5dB = 0.19	
0	1	1	0	1	0	X	X	-15.1dB = 0.18	
0	1	1	0	1	1	X	X	-15.7dB = 0.17	
0	1	1	1	0	0	X	X	-15.3dB = 0.15	
0	1	1	1	1	0	X	X	-16.8dB = 0.14	
0	1	1	1	1	1	X	X	-17.4dB = 0.13	
0	1	1	1	1	1	X	X	-18.0dB = 0.12	
0	X	X	X	X	X	1	1	IN3 Selected	
0	X	X	X	X	X	1	0	IN2 Selected	
0	X	X	X	X	X	0	1	IN1 Selected	
0	X	X	X	X	X	0	0	IN0 Selected	
1	X	X	X	X	X	X	X	Standby Mode - Powered Down	
1	1	1	1	1	1	1	1	Wake-up Condition (-18.0dB, IN3, Powered Down)	

Control Bits Logic Table

Bit	Function
B7	Standby - Power Down
B6	Gain Bit 4
B5	Gain Bit 3
B4	Gain Bit 2
B3	Gain Bit 1
B2	Gain Bit 0
B1	Input Select Bit 1
B0	Input Select Bit 0

Serial Timing Diagram

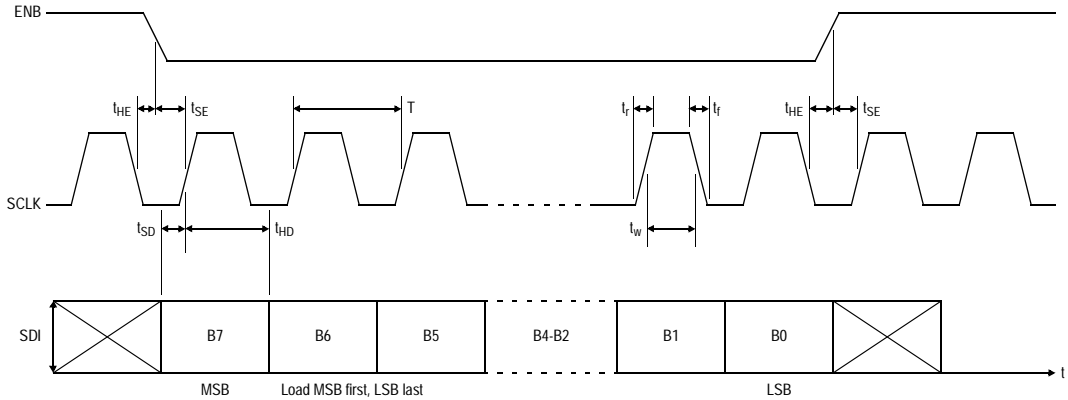

Serial Timing Parameters

Parameter	Example	Description
T	≥ 100 ns	Clock Period
t_r/t_f	$0.05 \times T$	Clock Rise/Fall Time
t_{HE}	≥ 40 ns	ENB Hold Time
t_{SE}	≥ 40 ns	ENB Setup Time
t_{HD}	≥ 40 ns	Data Hold Time
t_{SD}	≥ 40 ns	Data Setup Time
t_w	$0.50 \times T$	Clock Pulse Width

EL4102C - Preliminary

500MHz Video Front End: 4-1 MUX, VGA & DC-Restore

Pin Descriptions

Pin Number	Pin Name	Pin Type	Pin Description
1	HOLD	Logic Input	Hold pulse for DC-restore function
2	GNDL2	Logic Ground	Logic ground for "hold" buffer
3	IN0	High Frequency Signal	Video input #0
4	V _{S1+}	Power	Positive power pin for quiet supply currents
5	IN1	High Frequency Signal	Video input #1
6	GNDI	Analog Signal	Intermediate reference for attenuation function
7	IN2	High Frequency Signal	Video input #2
8	V _{S-}	Power	Negative power pin
9	IN3	High Frequency Signal	Video input #3
10	ENB	Logic Input	Enable (negative true) input for loading serial data stream
11	SDI	Logic Input	Serial input data stream
12	SCLK	Logic Input	Serial data stream clock
13	SDO	Logic Output	Serial output data stream for connection to cascaded chip
14	P _{DWN}	Logic Input	Power down input to put chip in low current standby mode
15	GNDL	Logic Ground	Logic ground for logic buffers
16	M _{FDBK}	High Frequency Signal	Monitor amplifier feedback
17	M _{OUT}	High Frequency Signal	Monitor amplifier output
18	V _{S-}	Power	Negative power pin
19	V _{S2+}	Power	Positive power pin for heavy, pulsatile supply currents
20	V _{OUT}	High Frequency Signal	Video amplifier output
21	V _{FDBK}	High Frequency Signal	Video amplifier feedback
22	DC _{FDBK}	Analog Signal	Input to sample circuit
23	DC _{REF}	Analog Signal	Reference DC voltage representing black level
24	CAP	Analog Signal	Sample storage capacitor for DC-restore circuit

Block Diagram (Gain of 1)

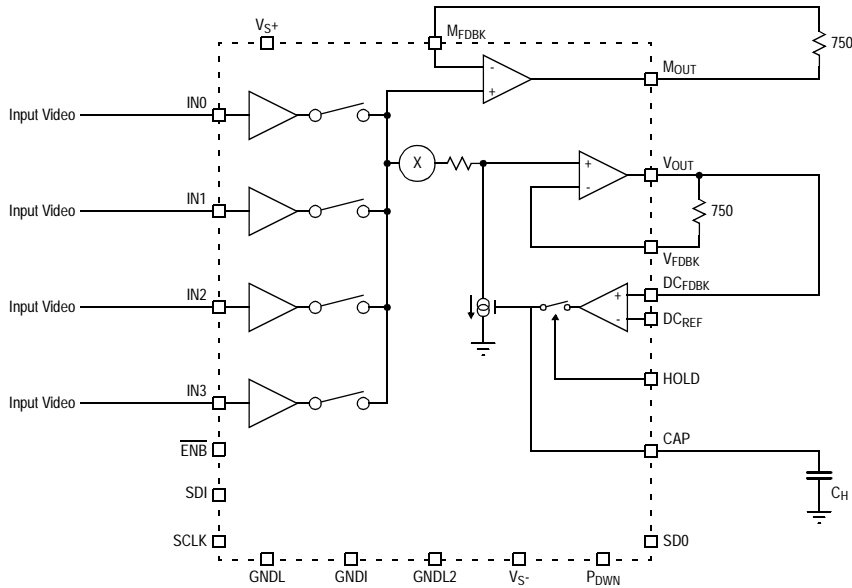

EL4102C - Preliminary

500MHz Video Front End: 4-1 MUX, VGA & DC-Restore

Applications Information

Using the Serial Data Output Connection for a Multi-chip Design

In a system design that uses three chips, (i.e. RGB, YUV, YPrPb systems) the control signal may be "daisy chained" through the three chips. This gives an advantage in that the control will be updated simultaneously on the three channels.

The serial data out (SDO) of chip one is connected to the serial data in (SDI) of chip two, similarly, chip two SDO is connected to SDI on chip three. The clock (SCLK) and enable (/ENB) signals are connected in parallel to all three chips. See figure yy for suggested interconnect of the control signals.

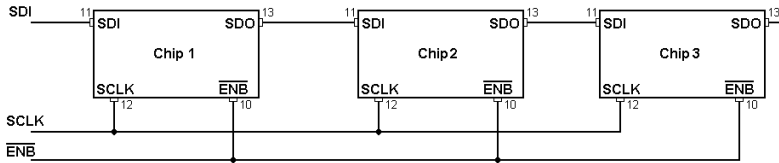
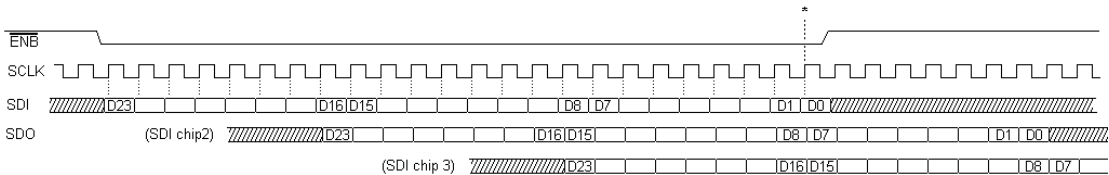

Figure xx shows the control signal waveforms when using this configuration. Note, that the last data bit clocked into the three chips occurs on the last positive clock edge that is within the enabled period. This will be D0 in the first chip, D8 and D16 on the second two chips. The rising edge of /ENB will then simultaneously

transfer the data internally to the chip. Typically the data for each chip is held as an image in the micro-controller system; the load operation would prepare the update information as a 24-bit word ready for shifting into the three chips.



EL4102C - Preliminary

500MHz Video Front End: 4-1 MUX, VGA & DC-Restore

General Disclaimer

Specifications contained in this data sheet are in effect as of the publication date shown. Elantec, Inc. reserves the right to make changes in the circuitry or specifications contained herein at any time without notice. Elantec, Inc. assumes no responsibility for the use of any circuits described herein and makes no representations that they are free from patent infringement.

élantec

HIGH PERFORMANCE ANALOG INTEGRATED CIRCUITS

Elantec Semiconductor, Inc.

675 Trade Zone Blvd.

Milpitas, CA 95035

Telephone: (408) 945-1323

(888) ELANTEC

Fax: (408) 945-9305

European Office: 44-118-977-6020

Japan Technical Center: 81-45-682-5820

WARNING - Life Support Policy

Elantec, Inc. products are not authorized for and should not be used within Life Support Systems without the specific written consent of Elantec, Inc. Life Support systems are equipment intended to support or sustain life and whose failure to perform when properly used in accordance with instructions provided can be reasonably expected to result in significant personal injury or death. Users contemplating application of Elantec, Inc. Products in Life Support Systems are requested to contact Elantec, Inc. factory headquarters to establish suitable terms & conditions for these applications. Elantec, Inc.'s warranty is limited to replacement of defective components and does not cover injury to persons or property or other consequential damages.